

**SUPREME  
COURT  
VOLUME-5  
ANNEXURES**

**SLP (C) No. 16308/2007-Ankur Gutkha Vs Indian  
Asthama Care Society & Ors-regarding.**

ARECA NUT SYMPOSIUM

Socio-economic aspects of areca nut use

R. CROUCHER & S. ISLAM

Adult Oral Health, Barts and The London, Queen Mary's School of Medicine and Dentistry, Queen Mary, University of London, UK

Abstract

The socio-economic aspects of areca nut consumption have been overlooked. A narrative review was conducted to establish some of these features of areca nut consumption. Medline, Pubmed and the World Wide Web were searched using the terms: areca nut, betel nut, areca catechu and pan masala. Further analysis was conducted of datasets describing aspects of United Kingdom areca nut sales and consumption. South Asian economies at different stages of development have varying areca nut cultivation practices, employment opportunities and marketing strategies. Attempts at regulation of areca nut import and sales are described. Retail practice among the South Asian communities of the United Kingdom was found to reflect the diverse consumer practices current in their countries of origin. A study of areca nut consumption patterns and motivations among Bangladeshi women resident in East London identified differences between those chewing areca nut in paan with and without tobacco. Further research into the socio-economic aspects of areca nut consumption is needed which should be multidisciplinary in focus, of sound scientific quality and incorporating the opinions of consumers.

Introduction

To discuss socio-economic aspects of areca nut use provides belated recognition of a neglected aspect of a multidimensional behaviour. The main thrust of research into areca nut use has been epidemiological, seeking to identify trends in behaviour and the resulting disease outcomes. Less attention has been given to the social aspects of areca nut consumption. This focus would widen the debate from a disease to a social model of health, recognizing that the determinants of health are broader than individual behaviours. The preventive focus has been upon developing messages for individual consumers, disregarding opportunities to introduce other policies and initiatives that focus upon other determinants of

this behaviour. Changing social and economic policies may lead to changing cultivation and marketing practice which will, in turn, affect individual consumption. The search for a preventive message has given inadequate attention to variations in areca nut use. In the United Kingdom the emphasis has been upon understanding a South Asian model of consumption, which is linked to positive sociocultural messages perceived as promoting increased consumption.<sup>1</sup> In other populations consumption could be different, because areca is associated with abundant availability and tradition.<sup>2,3</sup> Current estimates that 10% of the world's population are regular consumers, comprising perhaps 600 million people, suggest the desirability of widening per-

Correspondence to: Professor R. Croucher, Adult Oral Health, Barts and The London, Queen Mary's School of Medicine and Dentistry, Turner Street, London E1 2AD, UK. Tel: 020 7377 7632; fax: 020 7377 8481; e-mail: r.e.croucher@qmul.ac.uk

899  
E

spectives. A review was therefore conducted to establish and describe some of the relevant socio-economic features of areca nut consumption.

### Methods

This review has two strands. First, a search of existing literature sources was undertaken. Medline and Pubmed were searched using the search terms: areca nut, betel nut, areca catechu and pan masala. In addition the World Wide Web was accessed for a supplementary search focusing upon the production, processing and marketing of areca nut. Secondly, further analysis of data sets which describe aspects of areca nut sales and consumption within the United Kingdom was conducted.<sup>3-5</sup> Reflecting the limited nature of the resources available to describe the socio-economic aspects of areca nut use, the data are presented as a series of case studies.

### Results

#### *Changing areca nut cultivation*

*Areca catechu*, of which areca nut is a fruit, is one of the palm species. Palms are one of the oldest flowering plants. Initially native to Malaysia, *A. catechu* is now cultivated widely throughout India, Sri Lanka, Thailand and the Phillipines.<sup>6</sup> Palms offer a multiplicity of uses in a rural agrarian economy. They provide fodder for cattle, edible fruits, building materials, fuel and fibres. Gandhi argued that one species of palm had such a multiplicity of use that its cultivation and harvest would banish poverty from the land, while 1000 separate uses have been identified for the coconut palm.<sup>7</sup> The date palm is considered the staff of life by Moslems, recognizing the importance of the date in the breaking of the fast during Ramadan. The cultivation of *A. catechu* is traditionally described as an intercrop in India, alongside the piper betle, as a forest garden in Sumatra or as part of a private allotment.<sup>8,9</sup> The Nepalese government has introduced initiatives to encourage the private planting of species such as *A. catechu*.<sup>10</sup> This individual method of cultivation was mirrored by the complementary consumption of fresh perishable products, based around individual preferences and tastes.

The liberalization of economic policy, trends to urbanization and increased prosperity have introduced tensions into this traditional scenario. *A. catechu* may now be grown and prepared to meet

the needs of a mass market. The development of pan masala, a pre-packaged mix of areca nut, lime and spices, in India has been one response to this need. More pan masala is sold in urban than rural areas.<sup>11</sup> While still individually cultivated, the *A. catechu* tree is found increasingly in privately owned plantations to which a community will have limited access. Communities may well feel exploited and aggrieved, following the loss of a traditional right.<sup>9</sup> The development of areca nut as a market crop has resulted in it replacing other crops such as rice, cultivated previously for subsistence, and the introduction of fertilizer and pesticide applications to improve yields. As a cash crop rather than a rural garden tree, it has to be used to achieve maximum profit. Additional uses have been identified for the nut such as toothpaste, while the husk can be used to make paper or as a source of fuel for electrical power generation.<sup>12,13</sup>

The national and regional companies producing pan masala do so as part of a diverse range of products. The Kothari Group produce Pan Parag, a premium pan masala of fresh areca nuts, cardamom and lime, as part of a product range which includes tobacco products, coconut oil, washing powder, greeting cards, mineral water and writing pens.<sup>14</sup> Suppliers of the raw product for export can be located on the Web, most usually from Indonesia, where it is possible to purchase different qualities of nut in 50- or 85-kg sacks.<sup>15</sup>

The price for harvested areca nut in India appears volatile. In 1997 the government of India was asked to stop imports of areca and prevent smuggling, while by 1999 there were reports of a single premium quality areca nut costing more than a coconut (at 4-5 rupees). In general, the wholesale price appears to have fallen by about 30%, reflecting concerns about the impact of government bans on sales of the processed packaged product either as pan masala or, with tobacco added, as gutkha.<sup>16-18</sup>

#### *Changing employment opportunities*

The processing of areca nut in India has traditionally required the employment of a labour force, especially in preparing the nut for consumption. The nut has then been supplied to individual pan wallahs, from whom individual purchases could be made. Changing cultivation practices have resulted in the recruitment of a

permanent labour force to tend the trees who, in return, receive regular cash wages.<sup>8</sup> The aggressive marketing of pan masala has jeopardized the pan wallahs' livelihoods. There are reports of pan wallahs striking in one Indian town because of reduced profit margins due to the price they pay for areca nut doubling in 12 months.<sup>19</sup> The production of pan masala requires the integration of supplies of individual ingredients in addition to areca nut alone, all of which may be produced in different parts of India. Other industries associated with pan masala production are the spice and silver foil industries. This use of indigenous suppliers enables the Indian pan masala trade association to make the claim that their product is 'swadeshi', signifying a product using domestically supplied ingredients.<sup>20</sup>

One focus of this marketing activity has been on the urban Indian consumer. However, it is estimated that 70% of Indians live in rural areas. Growing rural affluence has led to the creation of a developing market for packaged goods which manufacturers have not been able to meet. This has been ascribed to factors such as inefficiencies in distribution through a fragmented transportation infrastructure. It has been noted that innovative methods of packaging have been introduced to bring down overall costs and create markets. As with products such as hair shampoo and toothpaste, the packaging of pan masala has been changed from containers to 10-g sachets. This change is considered responsible for an increase in sales in India from five million dollars in 1985 to 66 million dollars in 1991.<sup>21</sup>

#### *The regulation of areca nut marketing*

The regulation of areca nut and products such as pan masala is extremely difficult. First, the traditional method of consumption has involved the assembly of a quid with ingredients reflecting individual preferences. Secondly, there is a large informal sector, highly decentralized and unlicensed, which operates outside of official control. While the Indian government seeks to impose excise duty upon the sale of pan masala, it is also recognized that there is wholesale evasion of payment of the duty. Recently, pan masala with no tobacco and no more than 10% of areca nut by weight has had the rate of excise duty reduced from 40% to 16%.<sup>22</sup>

Within North America the US Food and Drugs Administration maintains an import 'alert' for

areca. Imports are automatically detained if detected on the grounds of it being 'adulterated, containing a poisonous or deleterious substance or unsafe food additives'. There are also reports of attempts to import areca nut by misbranding the product as 'fragrant wood slice'. This 'alert' is supported by the US Department of Agriculture. Commentators note the need for clarification of the status of this alert since US Customs advise that dried betel nuts should pay an import duty of 11 cents per kilo.<sup>23</sup>

Areca nut for personal consumption, 'pure nut, chopped and ready to chew', is readily available to purchase on the World Wide Web from American suppliers, at \$10 for 60 g and \$25 for 240 g, along with advice on consumption.<sup>24</sup> Possession of areca nut in the Californian public school system is grounds for suspension. The Food and Drugs Administration has also formally expressed a view to the US House of Representatives that individual possession for personal consumption should not be allowed.<sup>25</sup>

Within the United Kingdom, analysis of pre-packaged pan masala products has identified a group of problems.<sup>26</sup> First, labelling on the packaging was sometimes non-existent. Instructions as to use were also omitted. Secondly, the labelling might be unsatisfactory in omitting items which, on analysis, were found to be present. Thirdly, products contained non-permitted food additives, sometimes in excessive amounts. Samples of the raw ingredients such as pan leaves were also examined and found to be contaminated with salmonella. The labelling inadequacies would be expected to lead to prosecution of the importer of the product.

#### *The marketing of areca nut in the United Kingdom*

Two contrasting studies of retail practice in the United Kingdom have been carried out in London and Leicester.<sup>3,4</sup> The first investigation was carried out in 1996 to map the availability of paan ingredients in the London Boroughs of Tower Hamlets and Newham. First, the addresses of retail outlets selling paan ingredients were mapped. Secondly, a structured interview schedule was administered to the owners of each shop. The overall response rate for the interview was 76%. The schedule contained questions about the type of shop and its opening hours, which paan ingredients were sold, in what quantity and for what price. One hundred and twenty-eight shops

were identified as selling paan ingredients, 95 in Tower Hamlets and 33 in Newham. Reflecting both this geographic distribution and the dispersal of South Asian communities in London, more shops were owned by members of the Bangladeshi community in Tower Hamlets, while in Newham paan shops were owned predominantly by members of the Indian and Pakistani communities. Shopkeepers supplied products which reflected the expectations of their communities. The shops serving the Bangladeshi community provided a predominantly traditional product, i.e. supplies of loose areca nut, the betle leaf, lime and tobacco which were purchased for individual assembly and consumption. The shops supplying the diverse South Asian populations of Newham had a greater availability of pre-packaged areca nut.

The trade in all paan products (betle leaf, lime, areca nut and tobacco) in Tower Hamlets and Newham was estimated as approximately £1 million per year. Areca sales averaged 64 lbs weight a week for each retailer, with a range of 500–600 pounds weight. The retail price was approximately £1 per pound weight and the estimated weekly sales were £8538. These sales of areca nut were estimated to comprise approximately half of the total weekly sales of all paan products.

The hypothesis that retailers supply the products that they perceive their customers as needing has been supported by a second study carried out in Leicester. Adopting a methodology which mirrored the East London study, 60 retail outlets which served the predominantly Gujerati community and which had the potential to sell paan products were identified. Just over half of these retailers sold paan ingredients. However, in contrast to the East London retailers, the sale of pre-packaged pan masala products was much more common than the sale of individual ingredients. Most shops sold only pre-packaged products, although it was also reported that the Bangladeshi community primarily bought the fresh products. The authors' report suggests that the practice of consuming pre-packaged pan masala would start following visits to the Indian subcontinent. This argument would have less validity in Bangladesh. As the population is largely rural and poor and the transport infrastructure is undeveloped, visitors returning there would find that plain paan products would continue to be preferred.<sup>27</sup>

#### *The prevalence of areca nut consumption*

Within the United Kingdom there has been a series of studies of paan chewing, usually with or without the addition of tobacco.<sup>28–33</sup> Estimates of the prevalence of chewing paan vary from 45 to 95%. There are several possible reasons for this variation. First, the samples may not have been drawn from the same South Asian community. Secondly, there may have been variation in the wording of the questions. Studies may ask about experience of use ('have you ever had'), while others have inquired about current use. Questions have not always adequately defined the terms used, failing to distinguish between paan with and without tobacco. Thirdly, there has been variation in sampling practice. These studies are reviewed by Warnakulasuriya in this issue.

Commonly used factors to explain any variation might be age, gender and social class. As suggested above, the data to identify variation around these factors is not always available. Within these constraints:

- Several UK studies suggest that the age of starting to chew areca, usually in paan, is about 10 years.<sup>34–36</sup>
- At age of onset there appears to be no variation in gender, although older people eat more areca.<sup>11</sup>
- Consumption decreases with educational attainment.<sup>11</sup>
- Rural rather than urban communities consume more paan. In this context the rural–urban continuum may be interpreted as a proxy measure of social class, with urban communities being of higher social status.<sup>11</sup>
- The Bangladeshi community is the most socially disadvantaged of the three South Asian communities. Estimates of paan chewing in this community are high, reflecting its adoption by women as a method of consuming tobacco.<sup>34</sup>

The validated prevalence of paan chewing with tobacco by UK resident Bangladeshi women has been investigated.<sup>5</sup> The study design and data collection have been described elsewhere but, in brief, the investigation involved the selection at random of a group of 242 women resident on two local authority housing estates in the London Borough of Tower Hamlets. The study was conducted during 1998. The participants were interviewed using a previously piloted structured

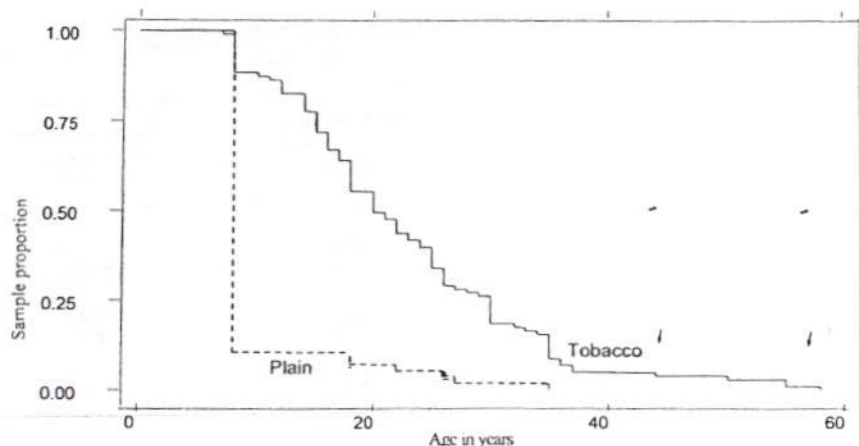

Figure 1. Retrospective age of starting current paan use (with and without tobacco) in a sample of Bangladeshi women ( $n = 166$ )

interview schedule containing questions about age, aspects of tobacco use and the degree of self-reported dependence upon tobacco. Validation of responses was achieved with carbon monoxide and cotinine concentration analysis. This validation exercise enabled the identification of a group of paan chewers without tobacco.

The outcomes of this study showed that 75% ( $n = 169$ ) of the whole sample were currently chewing either paan without or paan with tobacco. While 49% ( $n = 111$ ) of the whole sample were classified as current paan with tobacco chewers, 25% ( $n = 58$ ) were currently chewing a plain paan with basic ingredients of betle leaf, areca nut and lime without tobacco. Current plain paan chewers had a significantly younger mean age (32.4 years vs. 39.0 years,  $t = 4.0194$ ,  $p = 0.000$ ). The consumption patterns of plain paan chewers and paan with tobacco chewers differed in terms of the mean number of paan chewed daily (2.23 vs. 9.00,  $t = 6.905$ ,  $p = 0.000$ ), the age of starting their current practice (9.7 vs. 21.2 years,  $t = 8.342$ ,  $p = 0.000$ ) and the length of their chewing career (22.7 years vs. 17.9 years,  $t = 2.179$ ,  $p = 0.031$ ).

Figure 1 further clarifies the age at which the current paan chewing practice had commenced. The majority of plain paan chewers had started their current practice at or around the age of 8 years, while the impetus for starting to add tobacco to paan occurred at different times in the respondents' life spans. Fifty per cent of the paan with tobacco chewers had still to start their current tobacco consumption at the age of 20

years. These differences were tested using the log-rank test for equality of survivor functions and were found to be statistically significant.

The plain paan and paan with tobacco chewers also differed in their motivations and practice (Table 1). Plain paan chewers were more likely to cite 'refreshing' as their main reason for chewing whereas those chewing paan with tobacco most commonly cited 'habit' as their reason for chewing. While the paan with tobacco chewers were more likely to have their first paan of the day within 1 hour of waking, for those chewing plain paan this was more likely to happen at least 2 hours after waking. Finally, plain paan chewers reported only a moderate intention to stop this practice, compared to the paan chewers with tobacco who were more likely to report a strong intention to stop adding tobacco to their paan. These differences were tested using the chi-square test for trend and were found to be statistically significant.

#### Discussion

This paper has reviewed some of the socio-economic aspects of areca nut consumption. Data to support a comprehensive systematic review, reflecting the wide use of areca nut, is lacking. The sources used have their limitations, being dependent upon the geographic location and focus of academic research interest in areca nut and the geographic development of the World Wide Web. An emerging outcome has been the identification of a heterogeneous method of use,

1003  
8

Table 1. Paan quid consumption, with and without tobacco. Beliefs and behaviours in a sample of Bangladeshi women (n = 169)

Questionnaire item	Chew pan quid without tobacco (n = 58)	Chew pan quid with tobacco (n = 111)	Significance
Reason for chewing (%)			
habit	-	-	
refreshing	22.8	61.2	
helps teeth and gums	63.2	12.6	
other	7.0	22.3	0.000
other	7.0	3.8	
First paan quid of the day (%)			
within 1 hour	1	1	
within 1-2 hours	1.8	39.8	
2+ hours	7.0	26.2	
2+ hours	91.2	34.0	0.000
Intention to quit (%)			
none			
moderate	28.1	21.4	
strong	54.4	3.0	
strong	17.5	45.6	0.002

with variation within and between populations. The areca nut may be placed in a quid along with the piper betle leaf and lime, drunk in a beverage or shredded into pre-packaged pan masala. The areca nut itself may be consumed as a 'wet' or 'dry' solid. The quid may be chewed vigorously by some populations, while in others it is placed in the cheek for a more gentle mastication. All these factors inhibit the development of a robust evidence base, indicating the need to proceed on a case-study basis.

A second outcome has been the recognition that socio-economic trends in South Asia may serve to either reinforce existing patterns of consumption or lead to the development of marketing innovation. There is currently inadequate evidence to argue that the Bangladeshi socio-economic profile will lead to the diffusion of pan masala there, a mass-produced product reflecting the pattern of socio-economic change in India.

Thirdly, a focus on the health and behaviours of the United Kingdom South Asian communities, who make up about half of the United Kingdom ethnic minority population, has developed. This community is not a homogeneous group, differing along variables such as geographic distribution in the United Kingdom, educational attainment and economic prosperity. It cannot be assumed that their patterns of areca nut consumption will be similar. Further data collection should establish factors such as return travel to their families' country of origin where

areca nut consumption started, and any change in this behaviour over time.

Fourthly, accessible and robust data clearly distinguishing between individuals chewing areca nut in a made-up paan, pan masala or with tobacco is limited. Data from East London suggests that, in community samples, a group of adults reported their current areca nut chewing to be in paan without tobacco. This group was clearly distinguishable from a larger group chewing areca nut in paan with tobacco, with a differing consumption frequency, pattern and motivation. Reflecting these consumption patterns, epidemiological outcomes among those who chew paan without tobacco need further clarification against the international consensus reached in 1985.<sup>37</sup>

It may be concluded that the socio-economic aspects of areca nut production and consumption have been largely overlooked, inhibiting the identification of clear conclusions. This research should be multidisciplinary in focus and of high scientific quality. The consumer voice is currently ignored in the development of this research activity.

#### Acknowledgements

Sharif Islam is an MRC Health Services Research Training Fellow. Dr K. Chaudhry, from the Indian Council of Medical Research, made constructive comment on an earlier draft.

1004  
E

## References

- Summers RM, Williams SA, Curzon MEJ. The use of tobacco and betel quid ('pan') among Bangladeshi women in West Yorkshire. *Community Dent Health* 1994;11:12-16.
- Watson P. Does abundant supply of drugs lead to heavy consumption? A Papua New Guinea case study. May 1991 ([www.drugtext.org/articles/912405.htm](http://www.drugtext.org/articles/912405.htm)).
- Islam S, Croucher R, O'Farrell M. Paan ingredients trade in London boroughs of Tower Hamlets and Newham. Summary report of an investigation. London: Tower Hamlets Healthcare NHS Trust/The London Hospital Medical College; 1996.
- Ali M, Hamilton N, Khimani R, Patel S, Thomson S, Bennett J, House K. Sales of South Asian tobacco chewing products in Leicester City. Leicester: Leicester City Council Consumer Protection Service and Leicestershire Tobacco Paan Action Group; 2000.
- Croucher R. Tobacco in paan: implications for nicotine intake, dependence and cessation programmes in Bangladeshi women. Report of a project funded as part of the NHSE Inner City health research and Development Funding. London: Dental Public Health, St Bartholomew's and The Royal London School of Medicine and Dentistry; 1999.
- Rooney DF. Betel chewing traditions in South-East Asia. Kuala Lumpur: Oxford University Press; 1993.
- Dalibard C. The potential for tapping palm trees and prospects for animal production. Paper presented at the 2nd FAO Electronic Conference on Tropical Feeds ([www.fao.org/waicent/faoinfo/agricult/aga/agap/frg/ABSTRACT/DALIBARD.TXT](http://www.fao.org/waicent/faoinfo/agricult/aga/agap/frg/ABSTRACT/DALIBARD.TXT)).
- Bhat TN. Social change and family planning: a study of backward classes. *Man Devel* 1998;20: 115-45.
- Michon G, H de Foresta Juswaro, Levang P. Formal recognition of farmer's rights as a precondition for the re-building of productive and durable community forests in Indonesia: the Damar Agroforests in Krui, Sumatra, 1999 ([www.mtnforum.org/resources/library/michx99a.htm](http://www.mtnforum.org/resources/library/michx99a.htm)).
- Das AN. Perception and attitude towards tree growing in east Nepal ([www.panasia.org.sg/nepalnet/forestry/tree\\_grw.htm](http://www.panasia.org.sg/nepalnet/forestry/tree_grw.htm)).
- Trade briefing: pan masala (<http://hil.indiainfoonline.com/sect/ftob/ch06.html>).
- Rajsbekar SC. Biomass based power generation in Andaman and Nicobar Islands. BUN-India Newsletter 1999;3 ([www.144.16.65.129/~cgplhome/vol\\_31.html](http://www.144.16.65.129/~cgplhome/vol_31.html)).
- Grieve M. A modern herbal (<http://www.botanical.com/botanical/mgmh/a/areca056.html>).
- Kothari Product Range, 1997 (<http://www.newindia.com/kothari/>).
- PT Chempex Jaya, 1999 ([http://www.chempex.com/areca\\_nut.htm](http://www.chempex.com/areca_nut.htm)).
- Need to promote import of areca nut. Proceedings of Indian Parliament, 21.03.97 (<http://alfa.nic.in/lsdeb/ls11/ses4/14210397.htm>).
- Tuli P. Chewing troubles. *Hindustan Times*; 3rd August 1998 (<http://www.hindustantimes.com/nonfram/030898/met.htm>).
- Varma SM. Arecanut marketing to focus on exorcising pan masala stigma. *Financial Express*; January 31st 2000 (<http://www.financialexpress.com/fe/daily/20000131/fco31007.html>).
- Bhaumik A. Pan masala elbows Banarasi pan aside. *Economic Times*; 19th June 1999 (<http://www.economicstimes.com/190699/pageindu.htm>).
- George N. Health Ministry isolated on gutka ban. *Indian Express*, May 9 1998 ([www.expressindia.com/ie/daily/19980509/12950344.html](http://www.expressindia.com/ie/daily/19980509/12950344.html)).
- de Boer K, Fell G. A fresh look at India. *McKinsey Q* 1993;3:116-44 (<http://209.172.171.93/country/frlo93.asp>).
- Kapoor P, Iyengar J. Huge excise cut for pan masala with no tobacco. *Economic Times*; 19th June 1999 ([www.economicstimes.com/190699/19indu01.htm](http://www.economicstimes.com/190699/19indu01.htm)).
- McCrary S Van. The betel nut: an emerging public health threat? (<http://www.law.uh.edu/healthlawperspectives/HealthPolicy/980908Betel.html>).
- The basement shaman, Elgin, Illinois (<http://www.basementshaman.com/>).
- Food and Drug Administration. Statement for the Record by the Food and Drug Administration for the Committee on Resources, House of Representatives. April 13, 2000.
- Code of Practice for the safe handling and storage of paan ingredients in small to medium size retail shops. London Borough of Tower Hamlets Food Safety Team and The Dental School, Barts and The London School of Medicine and Dentistry, 2001.
- The World Bank Bangladesh. Bangladesh 2020: a long-run perspective study (wbln0018.worldbank.org/lo+web+sites/bangladesh+Web.nsf/0704a4348e105b2e462566720023975f/7798edeba2b94b034625670a0022c0e9).
- Rudat K. Black and minority ethnic groups in England: health and lifestyles. London: Health Education Authority; 1994.
- Nazroo JY. The health of Britain's ethnic minorities. London: Policy Studies Institute/Social and Community Planning Research; 1997.
- Summers RA, Williams SA, Curzon MEJ. The use of tobacco and betel quid ('pan') among Bangladeshi women in West Yorkshire. *Community Dent Health* 1996;11:12-16.
- Pearson N, Croucher R, Marcenes W, O'Farrell M. Dental service use and the implications for oral cancer screening in a sample of Bangladeshi adult medical care users living in Tower Hamlets, UK. *Br Dent J* 1999;186:517-21.
- Bedi R, Gilthorpe MS. The prevalence of betel-quid and tobacco chewing among the Bangladeshi community resident in a United Kingdom area of multiple deprivation. *Primary Dent Care* 1995;2: 3-42.

1905

E

33. Ahmed S, Rahman A, Hull S. Use of betel quid and cigarettes among Bangladeshi patients in an inner-city practice: prevalence and knowledge of health effects. *Br J Gen Pract* 1997;47:431-4.
34. Pearson N, Croucher R, Marcenes W, O'Farrell M. Dental service use and the implications for oral cancer screening in a sample of Bangladeshi adult medical care users living in Tower Hamlets, UK. *Br Dent J* 1999;186:517-21.
35. Asma S. A pilot investigation of betel chewing habit amongst a group of Bangladeshi adolescents in East London. Unpublished MSc thesis. Dental Public Health, University College London and The London Hospital Medical College, 1994.
36. Farrand P, Rowe RM, Johnston A, Murdoch H. Prevalence, age of onset and demographic relationships of different areca nut habits amongst children in Tower hamlets, London. *Br Dent J* 2001; 190:150-4.
37. International Association for Research on Cancer (IARC). Tobacco habits other than smoking: betel quid and areca nut chewing, and some related nitrosamines. Lyons: IARC; 1985.

11/11/2006  
N. O.T. 17-18/2009/9  
282/90  
7/12/09

## Oral submucous fibrosis: study of 1000 cases from central India

V. K. Hazarey<sup>1</sup>, D. M. Erlewad<sup>1</sup>, K. A. Mundhe<sup>2</sup>, S. N. Ughade<sup>3</sup>

<sup>1</sup>Department of Oral Pathology & Microbiology, Government Dental College & Hospital, Nagpur, India; <sup>2</sup>Department of Computer Science & Engineering, Government Engineering College, Amravati, India; <sup>3</sup>Department of Preventive & Social Medicine, Government Medical College, Nagpur, India

**BACKGROUND:** Very few reports have been published on the gender specificity of oral submucous fibrosis (OSF) in relation to habit patterns and the severity of disease in the world literature. The purpose of the study was to ascertain the gender specificity for different habits and severity of OSF.

**METHODS:** A hospital-based cross-sectional study on various habit patterns associated with OSF was performed in Nagpur over a 5-year period. A total of 1000 OSF cases from 266 418 out patients comprised the study sample.

**RESULTS:** The male-to-female ratio of OSF was 4.9:1. Occurrence of OSF was at a significant younger age group (<30 years) among men when compared with women (OR = 4.62, 3.22–6.63,  $P = 0.0001$ ). Reduced mouth opening, altered salivation and altered taste sensation were found to be significantly more prevalent in women when compared with men. Exclusive areca nut chewing habit was significantly more prevalent in women (OR = 44.5, 25.4–79.8,  $P = 0.0001$ ). Whereas significant increase for *Gutkha* (Areca quid with tobacco) (OR = 2.33, 1.56–3.54,  $P = 0.0001$ ) and *kharralMawa* (crude combination of areca nut and tobacco) (OR = 6.8, 4.36–11.06,  $P = 0.0001$ ) chewing was found in men when compared with women.

**CONCLUSIONS:** There is a marked difference in literacy, socioeconomic status, areca nut chewing habits, symptoms and disease severity in women when compared with men in the central Indian population.

*J Oral Pathol Med* (2007) 36: 12–17

**Keywords:** oral submucous fibrosis; descriptive study; gender; pan masala; oral cancer

### Introduction

Oral submucous fibrosis (OSF) is a high risk precancerous condition characterized by changes in the connective tissue fibers of the lamina propria and deeper parts leading to stiffness of the mucosa and restricted mouth opening. OSF has been reported almost exclusively among Indians living in India and among other Asians, with a reported prevalence ranging up to 0.4% in Indian rural population (1). Epidemiological and *in vitro* experimental studies have shown that chewing areca nut (*Areca catechu*) is the major aetiological factor for OSF (2).

Although there are regional variations in the type of areca nut products used in India, the betel quid (BQ) was the most popular and prevalent habit in ancient Indian culture. But in 1980, both areca quid products such as *Pan masala* (Areca quid) and *Gutkha* (AQ + tobacco) were introduced in Indian market as commercial preparations. Since then there has been an increase in the use *Pan Masala* (Areca quid) and *Gutkha* (AQ + T) in the younger age groups, which had led to increased incidence of OSF (3).

*Pan Masala* (Areca quid) includes areca nut, catechu, lime, flavours and spices. Our previous hospital-based case-control study has proved strong association of *Pan Masala* (AQ) with highest relative risk (489.1) of development of OSF (4). *Gutkha* (AQ + T) contains all ingredients of *Pan Masala* (AQ) plus tobacco and other contents, that are closely guarded secretes and is a commercial substitute to local preparation popularly known as *KharralMawa* (5).

Recently, it has been documented that the habit of chewing *Gutkha* (AQ + T) had gained considerable popularity among the younger men in this region. The rapidly increasing prevalence of this habit can be judged from the reports that the Indian market for *Pan masala* (AQ) and *Gutkha* (AQ + T) is worth 25 billion (US\$ 500 million) (6).

Many epidemiological studies on OSF have been published in world literature (1, 7, 8, 17, 19, 20, 23, 25). However, very few reports have been published on the

Correspondence: Dr Vinay Hazarey, Dean, Prof. and Head Department of Oral Pathology & Microbiology, Government Dental College & Hospital, Medical Campus, Aji, Nagpur 430 003, India. Tel: +91-712-2292002, Fax: +91-712-2743400, E-mail: vinay.hazarey@gmail.com, dimesh.erlewad@gmail.com  
Accepted for publication July 5, 2006

1007  
8

gender specificity of OSF in relation to habit patterns and the severity of disease (7). Given this paucity of information, a hospital-based cross-sectional study was performed to ascertain the gender specificity for different habits associated with OSF and the prevalence of oral cancer among these patients controlling for tobacco chewing habits.

### Materials and methods

A total of 266 418 patients visited the outpatient department of Government Dental College and Hospital, Nagpur, central India, in a 5-year period from January 2000 to December 2004. Out of these, 1000 patients were diagnosed for OSF and they comprised the study sample. Criteria for diagnosis of OSF were the presence of palpable fibrous bands in the labial and/or buccal mucosa, loss of elasticity of the buccal/labial mucosa and inability to open the mouth wide (1, 6). The clinical diagnosis was confirmed by biopsy in a subgroup of cases, using established criteria: submucosal dense and avascular collagenous connective tissue, variable number of chronic inflammatory cells and epithelial atrophy (8).

Complete clinical history including demographic details, various oral habits (the frequency number of times per day), duration (years of consumption) and type [Areca nut, *Kharrā Masua*, *Pan Masala* (AQ), *Gutkha* (AQ + T), BQ] along with tobacco use were recorded in case record forms.

### Data management and analysis

For the purpose of data entry, storage and retrieval, clinician-friendly graphical software programme 'SOFFPro 1.0' was specially designed and developed with the help of a qualified software programmer. Graphical user interface (GUI) screens were developed using Visual Basics 6.0 and database in MS Access. Designing of a suitable 'form' for data entry and 'format' for storage of information (computer screens) was done as per the structure of case record form for OSF.

All statistical analyses were performed using Internet-cooled STATA Version 8.0 (STATA corporation, Lakeway, TX, USA) software. Descriptive measures like mean values and standard deviations for continuous variables and percentage for categorical variables were calculated. The OSF cases were classified by gender for comparison purposes. Estimation of odds ratio (OR) along with 95% confidence intervals was made for comparing risk of OSF by gender. Tests of significance like unpaired *t*-test for comparing means and chi-squared test of association were performed for comparing percentages of two independent samples (men vs. women). A value of  $P < 0.05$  was considered statistically significant.

### Results

Year-wise prevalence of OSF in the study population is shown in Table 1. The overall prevalence of OSF was found to range from 2.42 in 2000 to 6.42 per 1000 per

Table 1. Year-wise prevalence of oral submucous fibrosis

Year	Cases	Sample size	Prevalence (per 1000 cases)
2000	152	62 587	2.42
2001	167	59 973	2.78
2002	168	48 848	3.43
2003	203	46 753	4.34
2004	319	48 257	6.42

year in 2004. Fig. 1 highlights the increasing trend in prevalence of OSF since 2000.

### Demographics

Table 2 shows the demographics of 1000 OSF cases. The mean age for men ( $n = 830$ ) was  $27.60 \pm 9.58$  (range 12–75) years and for women ( $n = 170$ ) it was  $34.78 \pm 12.21$  (range 9–75) years. Thus, occurrence of OSF was at a significantly younger age ( $< 30$  years) among men when compared with women (OR = 4.62, 3.22–6.63,  $P = 0.0001$ ). Prevalence of OSF in men (83%) was significantly ( $P < 0.0001$ ) more than in

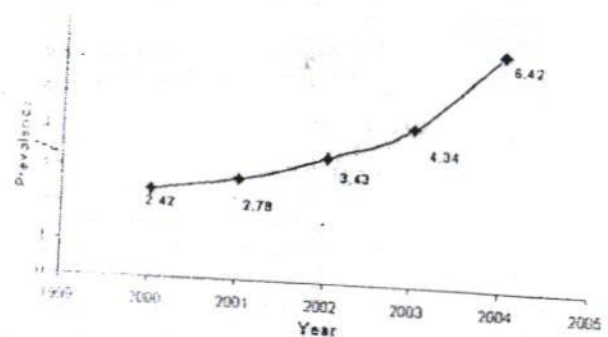

Figure 1. Prevalence of oral submucous fibrosis (per 1000 population) from 2000.

Table 2. Demographics of oral submucous fibrosis

Variables	Male (N = 830)		Female (N = 170)		Total (N = 1000)	
	No.	%	No.	%	No.	%
Age group						
0-9	-	-	1	0.6	1	0.6
10-19	180	21.7	23	13.5	203	35.2
20-29	439	52.9	42	24.7	481	77.6
30-39	131	15.8	59	34.7	190	50.5
40-49	55	6.6	30	17.6	85	24.3
50	25	3.0	15	8.8	40	11.8
Marital status						
Married	161	19.4	12	7.1	173	17.3
Unmarried	567	68.4	103	60.6	670	67
Divorced	51	6.1	44	25.8	95	9.5
Widowed	51	6.1	11	6.5	62	6.2
Socioeconomic status						
High	281	33.8	72	42.3	353	35.3
Medium	520	62.6	93	54.7	613	61.3
Low	13	1.5	2	1.1	15	1.5
Unemployed	16	1.9	3	1.7	19	1.9

1008  
5

Table 3 Symptoms and risk/distribution of OSF by gender

Symptom*	Male (N = 830)		Female (N = 170)		OR (95% CI)	P-value
	No.	%	No.	%		
Reduced mouth opening	747	90.0	161	94.7	1.98 (0.97-4.5)	0.053
Burning sensation	734	88.4	157	92.3	1.57 (0.85-3.15)	0.135
Ulceration	545	65.7	117	68.8	1.15 (0.89-1.67)	0.427
Altered salivation	307	36.9	86	50.6	1.41 (0.99-1.99)	0.043
Taste change	268	32.2	74	43.5	1.61 (1.13-2.29)	0.004
Dysphagia	205	24.7	53	31.2	1.38 (0.94-2.00)	0.078

\*Some patients had more than one symptoms of OSF.

women (17%) with male-to-female ratio being 4.9:1. Significantly higher proportions of women belonged to low socioeconomic status when compared with men (OR = 1.43, 1.00-2.04, P = 0.035). Proportion of illiterate women was significantly higher when compared with illiterate men (OR = 5.46, 3.38-8.74, P = 0.0001).

Table 3 shows the gender-wise distribution of symptoms in OSF cases at first presentation. Reduced mouth opening (OR = 1.98, 0.97-4.5, P = 0.053), altered salivation (OR = 1.41, 0.99-1.99, P = 0.043) and altered taste sensation (OR = 1.61, 1.13-2.29, P = 0.004) were found to be significantly more prevalent in women when compared with men.

**Chewing habits**

Out of 1000 patients, 77.8% (n = 778) patients were having multiple (more than one) habits, whereas 20.5% (n = 205) patients were having exclusive habits (only one habit), 1.7% (n = 17) patients did not give history of any habit. Average length of chewing for all cases was 21.5 ± 22.6 min with a mean frequency of chewing 1.28 ± 4.03 per day and mean duration of chewing 1.4 ± 3.59 years.

**Exclusive habits**

Table 4 gives the distribution and risk of OSF cases having exclusive habits (n = 192). Females have shown statistically significant increase in exclusive areca nut chewing habit (OR = 44.5, 25.4-79.8, P = 0.0001)

Table 4 Gender-wise risk/distribution of oral submucous fibrosis with exclusive habits

Variables	Male (N = 830), n (%)	Female (N = 170), n (%)	OR (95% CI)	P-value
Areca nut				
Yes	20 (2.40)	89 (52.35)	44.5 (25.4-79.8)	0.0001
No	810 (97.59)	81 (47.64)		
Kharrā				
Yes	38 (4.57)	0 (0)	-*	
No	792 (95.42)	170 (100)		
Gutkha				
Yes	35 (4.21)	02 (1.17)	3.69 (0.93-32)	0.0557
No	795 (95.78)	168 (98.82)		
Tobacco				
Yes	05 (0.60)	03 (1.76)	2.96 (0.45-15.3)	0.1212
No	825 (99.39)	167 (98.23)		

\*OR values cannot be calculated because of zero cell frequency

when compared with men, but significant increase for Gutkha (AQ + T) (OR = 3.69, 0.93-32, P = 0.05) and kharrā/Mawa chewing was found in men when compared with women.

**Multiple habits**

Table 5 gives the distribution and risk of OSF patient with multiple habits (n = 791). There was a statistical significant increase in areca nut chewing (OR = 2-12.10-54.17, P = 0.0001). Kharrā/Mawa chewing (OR = 6.8, 4.36-11.06, P = 0.0001), Gutkha (AQ + T) chewing (OR = 2.33, 1.56-3.54, P = 0.0001) and smoking habits (OR = 12.8, 5.3-40.6, P = 0.0001) in men when compared with women. Although BQ chewing and the use of snuff for teeth cleaning were proportionate higher in men, they were not found to be statistical significant.

**Associated lesions**

In the present sample, major pre-malignant lesion associated with OSF were leukoplakia (4.8%) and lichen planus (0.7%) followed by erythroplakia (0.2%) and Betel chewer's mucosa (0.7%).

Table 5 Gender-wise risk/distribution of OSF with multiple habit

Variables	Male (N = 830), n (%)	Female (N = 170), n (%)	OR (95% CI)	P-value
Areca nut				
Yes	476 (57.34)	09 (5.29)	24 (12.10-54.17)	0.000
No	354 (42.65)	161 (94.70)		
Kharrā				
Yes	459 (55.30)	26 (15.29)	6.8 (4.36-11.06)	0.000
No	371 (44.69)	144 (84.70)		
Gutkha				
Yes	345 (41.56)	37 (21.76)	2.33 (1.56-3.54)	0.000
No	531 (63.97)	133 (78.23)		
Tobacco				
Yes	275 (33.13)	41 (24.11)	1.55 (1.05-2.34)	0.02
No	555 (66.86)	129 (75.88)		
Snuff				
Yes	230 (27.71)	37 (21.76)	1.37 (0.91-2.10)	0.11
No	600 (72.28)	133 (78.23)		
Smoking				
Yes	233 (28.07)	05 (2.94)	12.8 (5.3-40.6)	0.000
No	597 (71.92)	165 (97.05)		
Betel quid				
Yes	108 (13.01)	16 (9.41)	1.43 (0.81-2.68)	0.11
No	722 (86.98)	154 (90.58)		

\*All of these patients had more than one habit

1009  
 E

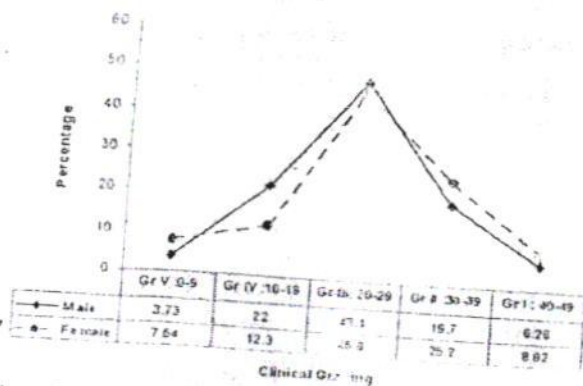

Figure 2 Gender-wise distribution of clinical grading by mouth opening

**Clinical grading**  
 Fig. 2 depicts the gender-wise distribution of clinical grading of OSF (mouth opening in millimetres), where men and women were equally (48.3%) affected with grade III (20–29 mm) severity.

**Pattern of oral cancer in OSF**  
 Out of a total of 33 malignant cases, 28 cases (2.8%) were squamous cell carcinomas and five cases (0.5%) were verrucous carcinomas. This accounts for 3.3% malignancy potential in the present study. Table 6 gives the comparison of all the habits between malignant and non-malignant OSF cases. We have found that malignancy in OSF cases was significantly associated ( $P < 0.05$ ) with increased frequencies of BQ chewing and smoking as well as increased durations of tobacco chewing, BQ chewing and smoking habits.

**Discussion**

Oral submucous fibrosis is a pre-malignant condition, which has been described in detail in Asians and Asians settled in other countries. Describing the condition in five Indian women, Schwartz (9) called it 'atrophia idiopathica mucosae oris'. Subsequently, Joshi called it submucous fibrosis (10). Various aetiological factors have been suggested for OSF, which include local irritant such as capsaicin (11), pungent and spicy food

(12) and areca nut use (1). In addition to the local factors, systemic factors have also been suggested to play a role in the development of OSF. These include anaemia, chronic iron and vitamin B deficiency (13) and genetic pre-disposition (14).

Chewing areca nut in its various forms is widely prevalent in the Indian subcontinent, giving rise to increased prevalence of OSF, from an estimated 250 000 cases in 1980 (15) to an estimated 5 million people in 2002 (16).

In present study, an increasing trend in prevalence for OSF was observed since 2000 (2.42 in 2000 to 6.42/1000/cent in 2004). The period prevalence rate for 2004 was comparable with other Indian and Malaysian studies (17, 18), and less when compared with studies from China and Taiwan (19, 20). This striking difference between the prevalence rates may be attributable to long history of chewing habits, and an important role of areca/BQ in Taiwanese cultural activities (20).

The mean age of all cases affected with OSF was  $28.8 \pm 10.4$  years, which is relatively a younger age when compared with south Indian ( $32.4 \pm 10.4$  years) and north Indian ( $30.42 \pm 10.86$ ) OSF cases (21, 22). There are very few reported cases of children affected with OSF (23, 24). In the present study, we have found OSF in the youngest, 9-year-old girl and 12-year-old boy.

Our study showed a high preponderance of OSF in men (49:1), which is similar to a male preponderance reported by various authors (5, 21, 22). However, few studies have reported female preponderance (25–28). Inability to open the mouth wide was the chief complaint (90.8%), which clearly suggests that one of the diagnostic signs of the disease, is restricted mouth opening (29–31). In the present study, there were 17 cases with no history of areca nut chewing, tobacco chewing or smoking habits. Seedat and Van Wyk (32) from South Africa made similar observations in OSF patients.

In the present study, posterior one-third of oral cavity (both buccal mucosae, retromolar area and soft palate) was predominantly affected, which is similar to the observations from Pune group from Maharashtra state and in contradiction with findings from Ernakulam group from Kerala state, where labial mucosa was

Table 6 Comparison of mean frequency (per day) and durations (years) of BQ chewing habits in malignant and non-malignant oral submucous fibrosis cases

Habits	Frequency (per day)		P-value	Duration (years)		P-value
	Malignant (n = 33)	Non-malignant (n = 967)		Malignant (n = 33)	Non-malignant (n = 967)	
Areca nut	2 ± 3	1.5 ± 4.1	0.901	3.6 ± 7.3	2.85 ± 6.0	0.507
Tobacco	2.3 ± 4.1	1.9 ± 3.7	0.544	4.2 ± 7.1	2.23 ± 5.2	0.033
Kharra	3 ± 3.1	2.8 ± 6.8	0.995	4.2 ± 5.9	2.50 ± 3.4	0.033
Betel quid	1.2 ± 2.7	0.3 ± 1.3	0.001	2.4 ± 6.2	0.74 ± 3.2	0.015
Gutkha	4 ± 8.4	1.6 ± 6.3	0.732	2.6 ± 4.6	2.35 ± 3.6	0.006
Snuff	0.4 ± 0.9	0.7 ± 0.9	0.141	1.2 ± 4.3	1.21 ± 4.1	0.731
Smoking	3.4 ± 6.9	1.0 ± 3.6	0.001	1.0 ± 3.5	1.07 ± 3.5	0.384
						0.005

Values are given as mean ± SD

10/10  
 2

significantly affected, which represents a regional variation with respect to various chewing habits practised in different parts of India (33).

Women have shown statistically significant increase for exclusive areca nut chewing habit when compared with men, which is mainly attributable to the local cultural practices and easy availability of areca nut. Similar finding had been reported by several studies in Asian and South African population (25, 34). Inversely, men have shown statistically significant increase in *Gutkha* (AQ + T) and *Kharra/Mawa* chewing habits. This finding justified that the commercial product *Gutkha* (AQ + T) have equated with the local preparation *Kharra/Mawa*. Negligible number of female smokers ( $n = 5$ ) was found in our study as it was in Yang's study (27).

In the present study, majority of OSF (48.3%) cases were in grade III (20–29 mm) severity with an average mouth opening of 24.62 mm, which is in contrast with Cox's study (35), who found an average mouth opening of 34 mm in the Nepalese OSF cases. Our study also revealed a strong association between the incidence of leukoplakia (4.8%) and OSF, which might be attributed to BQ chewing and smoking habits (36).

Although this study was not designed as a case-control study, we tried to evaluate by calculating OR with group comparisons, the association between OSF and other baseline characteristics, which highlighted the significant association of OSF with younger age, illiteracy, low socioeconomic status and various chewing products.

In this study, a malignant potential of 3.3% was noted. These malignant OSF cases have shown statistically significantly increased frequencies and duration of BQ, tobacco chewing as well as smoking habits when compared with non-malignant cases. This finding confirms that tobacco plays a modifying effect on malignant transformation in OSF. A similar malignant potential (3.6%) was noted by Caniff in Durban, South Africa (37).

The present study also confirms the fact that the increased *Gutkha* (AQ + T) chewing habit, which has substituted the BQ and *Kharra/Mawa* use in this region has not only given rise to increased prevalence of OSF but also can give rise to increased incidence of oral cancer among these patients mainly because of its tobacco and other carcinogenic additives.

We hypothesize from the present epidemiological study that there is a marked difference in habits, their frequency and duration, signs and symptoms and disease severity in women when compared with men seeking dental care for OSF at tertiary level in the central Indian population. The present cross-sectional study, to the best of our knowledge, is the single largest report on OSF so far published from India.

### Conclusion

The impression of emerging prevalence of OSF since 2000 (0.42–0.64%), in relatively younger population in India seems to be justified by the data observed in the

present study. Urgent regulatory actions are therefore warranted to control the manufacture, marketing and the consumption of products that contain areca nut and or tobacco, especially *pan masala* and *Gutkha*. Specific efforts are needed to educate the adolescent population using available modalities such as oral health exhibition and camps.

### Endorsement

I, the undersigned, Dr (Mrs) S.M. Ganvir, hereby endorse that, the data used for the research titled 'Oral submucous fibrosis: study of 1000 cases from central India' are hospital based and were obtained from patients who visited the Department of Oral Pathology and Microbiology, Government Dental College and Hospital, Nagpur, Maharashtra, India, during the period January 2000 to December 2004.

I have verified the claimed conclusions and found them correct as per the results obtained from this study.  
Dr (Mrs) S. M. Ganvir  
Professor,  
Department of Oral Pathology & Microbiology,  
Government Dental College and Hospital,  
Nagpur (MS), India

### References

- Murti PR, Bhonsle RB, Gupta PC, Dattary DK, Pindbor JJ, Mehta FS. Etiology of oral submucous fibrosis with special reference to the role of areca nut chewing. *J Oral Pathol Med* 1995; 24: 145–52.
- Caniff JP, Harvey W. The etiology of oral submucous fibrosis: the stimulation of collagen synthesis by extracts of areca nut. *Int J Oral Surg* 1981; 10(Suppl): 163–7.
- Gupta PC, Sinor PN, Bhonsle RB, Pawar VS, Mehta H. Oral submucous fibrosis in India: a new epidemic? *N Med J India* 1998; 11: 113–6.
- Hazarey VK, Goel RR, Gupta PC. Oral submucous fibrosis, areca nut and pan masala use: a case control study. *Natl Med J India* 1998; 11: 299.
- Sinor PN, Gupta PC, Murti PR et al. A case control study of oral submucous fibrosis with special reference to the etiologic role of areca nut. *J Oral Pathol Med* 1990; 19: 94–8.
- Gupta PC, Ray CS. Epidemiology of Betel quid use. *Ann Acad Med Singapore* 2004; 33(Suppl): 51–6.
- Merchant AT, Haider SM, Fikree FF. Increased severity of oral submucous fibrosis in young Pakistani men. *Br Oral Maxillofac Surg* 1997; 35: 284–7.
- Neville BW, Damm DD, Allen CM, Bouquot JE. Epithelial pathology. In: Neville BW, Damm DD, Allen C, Bouquot JE, eds. *Oral and maxillofacial pathology*, 2 edn. Delhi, New Delhi, India: WB Saunders Publication; 2002; 349–50.
- Schwartz J. Atrophia idiopathica (tropical) mucosae or In: *Proceedings of the 11th International Dental Congress*, London, 1952 (cited by Sirsat and Khanolkar). *India Med* 1962; 16: 185–197.
- Joshi SG. Submucous fibrosis of the palate and pharynx. *Indian J Otolaryngol* 1953; 4: 1–4.
- Sirsat SM, Khanolkar VR. Submucous fibrosis of the palate in diet pre-conditioned Wistar rats, induced by

- painting of capsaicin-optical and electron microscopic study. *Arch Pathol* 1960; 70: 171-9.
12. Pindborg JJ, Sivasai SM. Oral submucous fibrosis. *Oral Surg Oral Med Oral Pathol* 1966; 22: 764-79.
  13. Rajendran R. Oral submucous fibrosis. etiology, pathogenesis and future research. *Bull World Health Organ* 1994; 72: 985-96.
  14. Caniff JP, Batchelor JR, Dodi K, Harvey W. HLA typing in oral submucous fibrosis. *Tissue Antigens* 1985; 26: 138-42.
  15. Cox SC, Walker DM. Oral submucous fibrosis: a review. *Aust Dent J* 1996; 41: 294-9.
  16. Chiu CJ, Chang ML, Chiang CP, Hahn LJ, Hsieh LL, Chen CJ. Interaction of collagen-related genes and susceptibility to betel quid-induced oral submucous fibrosis. *Cancer Epidemiol Biomarkers Prev* 2002; 11: 646-53.
  17. Gupta PC, Sinor PN, Bhonsle RB, Pawar VS, Mehta HC. Oral submucous fibrosis in India: a new epidemic? *Natl Med J India* 1998; 11: 113-6.
  18. Zain RB, Ikeda N, Gupta PC et al. Oral mucosal lesions associated with betel quid, areca nut and tobacco chewing habits: consensus from a workshop held in Kuala Lumpur, Malaysia, November 25-27 1996. *J Oral Pathol Med* 1999; 28: 1-4.
  19. Tang JG, Jian XF, Gao ML, Ling TY, Zhang KH. Epidemiological survey of oral submucous fibrosis in Xiangtan city, Hunan province, China. *Community Dent Oral Epidemiol* 1997; 25: 177-80.
  20. Yang YH, Lee HY, Tung S, Shieh TY. Epidemiological survey of oral submucous fibrosis and leukoplakia in aborigines of Taiwan. *J Oral Pathol Med* 2001; 30: 213-9.
  21. Ranganathan K, Umadevi M, Joshua E, Kirankumar K, Saraswathi TR. Oral submucous fibrosis: a case control study in Chennai, South India. *J Oral Pathol Med* 2004; 33: 274-7.
  22. Shah N, Sharma PP. Role of chewing and smoking habits in the etiology of oral submucous fibrosis (OSF): a case-control study. *J Oral Pathol Med* 1998; 27: 475-9.
  23. Hayes PA. Oral submucous fibrosis in a 4-year-old girl. *Oral Surg Oral Med Oral Pathol* 1985; 59: 475-8.
  24. Yusuf HL, Yong SL. Oral submucous fibrosis in a 12-year-old Bangladeshi boy: a case report and review of literature. *Int J Paediatr Dent* 2002; 12: 271-6.
  25. Meher R, Lee AL, Warnakulasuriya KAAS, Lewis LA, Johnson NW. Role of areca nut in the causation of oral submucous fibrosis: a case control study in Pakistan. *J Oral Pathol Med* 1994; 23: 65-9.
  26. Pindborg JJ, Mehta FS. Prevalence of SMF in 50,915 Indian villagers. *Br J Cancer* 1968; 22: 464-54.
  27. Yang YH, Lien YC, Ho PS et al. The effects of chewing areca/betel quid with and without cigarette smoking on oral submucous fibrosis and oral submucosal lesions. *Oral Dis* 2005; 11: 88-94.
  28. Zain RB, Ikeda N, Razak IA et al. A national epidemiological survey of oral mucosal lesions in Malaysia. *Community Dent Oral Epidemiol* 1997; 25: 377-83.
  29. Mani NJ, Singh B. Studies on oral submucous fibrosis. I. Clinical aspect. *J Indian Acad Dent* 1968; 9: 27-36.
  30. Darius K. Paissat oral submucous fibrosis. *Int J Oral Surg* 1981; 10: 307-12.
  31. Chiu CJ, Lee WC, Chiang CP, Hahn LJ, Kuo YS, Chen CJ. A scoring system for the early detection of oral submucous fibrosis based on a self-administered questionnaire. *J Public Health Dent* 2002; 62: 28-31.
  32. Seedar H, Van Wyk CW. Submucous fibrosis in non-betel nut chewing subjects. *J Biol Buccale* 1988; 16: 3-6.
  33. Bhonsle RB, Murthi PR, Daftary DK et al. Regional variations in oral submucous fibrosis in India. *Community Dent Oral Epidemiol* 1987; 15: 225-9.
  34. Seedar HA, Van Wyk CW. Betel-nut chewing and submucous fibrosis in Durban. *S Afr Med J* 1988; 74: 68-71.
  35. Cox SC, Walker DM. Establishing a normal range for mouth opening: its use in screening for oral submucous fibrosis. *Br J Oral Maxillofac Surg* 1997; 35: 40-2.
  36. Lee CH, KO YC, Hang HI et al. The precancer risk of betel quid chewing, tobacco use and alcohol consumption in oral leukoplakia and oral submucous fibrosis in southern Taiwan. *Br J Cancer* 2003; 88: 366-72.
  37. Caniff JP, Harvey WJ. Oral submucous fibrosis pathogenesis and management. *Br Dent J* 1986; 160: 429.

### Acknowledgements

The authors thank Dr (Mrs) S. M. Ganvir, Professor, Department of Oral Pathology and Microbiology, Nagpur, India, and Dr P. C. Gupta, Director, Health, Sekhsaria Institute for Public Health, Navi Mumbai, for their valuable suggestions.

Cancer Causes Control. 2002 Feb;13(1):55-64.

## Body mass index, tobacco chewing, alcohol drinking and the risk of oral submucous fibrosis in Kerala, India.

Hashibe M, Sankaranarayanan R, Thomas G, Kuruvilla B, Mathew B, Somanathan T, Parkin DM, Zhang ZF.

Department of Epidemiology, UCLA School of Public Health and Jonsson Comprehensive Cancer Center, Los Angeles, CA 90095-1772, USA.

### Abstract

**OBJECTIVE:** While chewing areca nut is considered a risk factor for oral submucous fibrosis, the effects of cigarette smoking, alcohol drinking, and body mass index (BMI) have not been examined; nor are they well established. In this study we investigated the association between BMI, smoking, drinking, and the risk of oral submucous fibrosis.

**METHODS:** We conducted a case-control study within the framework of an ongoing randomized oral cancer screening trial in Kerala, India. Trained health workers conducted interviews with structured questionnaires and oral visual inspections to diagnose oral premalignant lesions. A total of 170 oral submucous fibrosis cases (139 women and 31 men) and 47,773 controls were identified. The odds ratios (OR) and 95% confidence intervals (CI) were calculated by logistic regression in SAS.

**RESULTS:** The adjusted OR for ever-tobacco chewing was 44.1 (95% CI = 22.0-88.2). An inverse dose-response relationship was seen between BMI and the risk of oral submucous fibrosis when both genders were combined ( $p$  for trend = 0.0010), with an OR of 0.5 (95% CI = 0.3-0.9) for the highest BMI quartile compared to the lowest. Alcohol drinking may possibly be associated with the risk of oral submucous fibrosis; the adjusted OR for ever drinking was 2.1 (95% CI = 1.0-4.4). Cigarette smoking did not appear to be a risk factor for women or for men. Both smoking and drinking were rare habits among women.

**CONCLUSION:** This study suggested, for the first time, that BMI was inversely associated with the risk of oral submucous fibrosis for both genders when potential confounding factors were adjusted. Our results indicated that alcohol drinking might be a moderate risk factor and confirmed the previous observation that chewing tobacco was a strong risk factor for oral submucous fibrosis.

# Cancer Epidemiology, Biomarkers & Prevention

AACR

## Chewing Tobacco, Alcohol, and the Risk of Erythroplakia

Mia Hashibe, Babu Mathew, Binu Kuruvilla, et al.

*Cancer Epidemiol Biomarkers Prev* 2000;9:639-645. Published online July 1, 2000.

**Updated Version** Access the most recent version of this article at:  
<http://cebp.aacrjournals.org/content/9/7/639>

**Cited Articles** This article cites 21 articles, 3 of which you can access for free at:  
<http://cebp.aacrjournals.org/content/9/7/639.full.html#ref-list-1>

**Citing Articles** This article has been cited by 6 HighWire-hosted articles. Access the articles at:  
<http://cebp.aacrjournals.org/content/9/7/639.full.html#related-urls>

**E-mail alerts** Sign up to receive free email-alerts related to this article or journal.

**Reprints and Subscriptions** To order reprints of this article or to subscribe to the journal, contact the AACR Publications Department at [pubs@aacr.org](mailto:pubs@aacr.org).

**Permissions** To request permission to re-use all or part of this article, contact the AACR Publications Department at [permissions@aacr.org](mailto:permissions@aacr.org).

1914

## Chewing Tobacco, Alcohol, and the Risk of Erythroplakia<sup>1</sup>

Mia Hashibe, Babu Mathew, Binu Kuruvilla, Gigi Thomas, Rengaswamy Sankaranarayanan, Donald Maxwell Parkin, and Zuo-Feng Zhang<sup>2</sup>

Department of Epidemiology, University of California-Los Angeles School of Public Health, Los Angeles, California 90095-1772 [M. H., Z-F. Z.]; Regional Cancer Centre, Trivandrum 695011, India [B. M., B. K., G. T.]; and Unit of Descriptive Epidemiology, IARC, 69372, Lyon Cedex 08, France [R. S., D. M. P.]

### Abstract

Although chewing tobacco, smoking, and alcohol drinking have been suggested as risk factors for oral cancer, no study has examined the relationship between those factors and the risk of erythroplakia, an uncommon but severe oral premalignant lesion. In this study, we have analyzed the effects of chewing tobacco, smoking, alcohol drinking, body mass index, and vegetable, fruit, and vitamin/iron intake on the risk of erythroplakia and explored potential interactions between those factors in an Indian population. A case-control study including 100 erythroplakia cases and 47,773 controls was conducted, as part of an on-going randomized oral cancer screening trial in Kerala, India. The analysis was based on the data from the baseline screening for the intervention group, where the diagnostic information was available. The information on epidemiological risk factors was collected with interviews conducted by trained health workers. The erythroplakia cases were identified by health workers with oral visual inspections, and then confirmed by dentists and oncologists who made the final diagnosis. The odds ratios (OR) and their 95% confidence intervals (CIs) were calculated by the logistic regression model using SAS software. The adjusted OR for erythroplakia was 19.8 (95% CI, 9.8-40.0) for individuals who had ever chewed tobacco, after controlling for age, sex, education, body mass index, smoking, and drinking. The adjusted OR for ever-alcohol-drinkers was 3.0 (95% CI, 1.6-5.7) after controlling for age, sex, education, body

mass index, chewing tobacco, and smoking. For ever-smokers, the adjusted OR was 1.6 (95% CI, 0.9-2.9). A more than additive interaction on the risk of erythroplakia was suggested between tobacco chewing and low vegetable intake, whereas a more than multiplicative interaction was indicated between alcohol drinking and low vegetable intake, and between drinking and low fruit intake. We concluded that tobacco chewing and alcohol drinking are strong risk factors for erythroplakia in the Indian population. Because the CIs of interaction terms were wide and overlapping with those of the main effects, only potential interactions are suggested.

### Introduction

Oral cancer is the most common site of cancer for men and the third most common site of cancer for women in Trivandrum, which is located in the state of Kerala, India. The high incidence of oral cancer in Kerala has been attributed to tobacco chewing, tobacco smoking, and alcohol drinking (1-3). Tobacco is chewed predominantly as an ingredient of betel quid or pan, which is a combination of betel leaf, areca nut, and lime. It is smoked mostly in the form of bidi (a native cigarette of coarse tobacco hand-rolled in a dry tembhurni leaf) and cigarettes.

The study of oral premalignant lesions is of importance for the prevention of oral cancer because premalignant lesions may be treated to prevent their progression to oral cancer or used as surrogate (intermediate) markers for oral cancer intervention. Cessation of chewing tobacco and smoking has been associated with the regression of oral leukoplakia, a common oral premalignant lesion (4). Dietary supplements of vitamin A and  $\beta$ -carotene have also been implicated in the regression as well as in the prevention of oral leukoplakia (5-7). Although several studies have been conducted on risk factors for oral leukoplakia, very few have focused on erythroplakia, the most advanced type among oral premalignant lesions.

Erythroplakia is an uncommon but severe disease, defined by WHO as "any lesion of the oral mucosa that presents as bright red velvety plaques which cannot be characterized clinically or pathologically as any other recognizable condition" (8). An updated definition for erythroplakia was proposed by Bouquot (9) as "a chronic red mucosal macule which cannot be given another specific diagnostic name and cannot be attributed to traumatic, vascular, or inflammatory causes". Erythroplakia patches may be located near, or associated with, oral leukoplakias. Bouquot and Whitaker (10) suggested that erythroplakia may occur with leukoplakia in the stage called erythroleukoplakia. Erythroplakia has been considered the most severe form among all of the oral premalignant lesions because of its high malignant potential (11). When erythroplakia biopsies were studied, 91% were dysplasia, carcinoma *in situ*, or cancer (12).

There are very few studies on the prevalence of erythroplakia. When 65,354 cases from two oral pathology departments were reviewed, 58 erythroplakia cases were identified

Received 6/21/99; revised 3/15/00; accepted 4/12/00.

The costs of publication of this article were defrayed in part by the payment of page charges. This article must therefore be hereby marked *advertisement* in accordance with 18 U.S.C. Section 1734 solely to indicate this fact.

<sup>1</sup> The Trivandrum oral cancer screening project is supported by a generous grant from the Association for International Cancer Research (AICR), St. Andrews, Scotland. Additional data collection in this study is supported by the Imperial Cancer Research Fund (ICRF), United Kingdom. The analysis was carried out by M. H. under an IARC special training award during the summer of 1998, in the Unit of Descriptive Epidemiology, IARC, Lyon, France. This project is also supported in part by Grants CA77954, CA09142, and CA16042 from the National Cancer Institute, NIH, Department of Health and Human Services; by a seed grant from University of California-Los Angeles Jonsson Cancer Center Foundation, and by the Weissman Fund.

<sup>2</sup> To whom requests for reprints should be addressed, at: Department of Epidemiology, University of California-Los Angeles School of Public Health, 71-225 CHS, Box 951772, Los Angeles, CA 90095-1772. Phone: (310) 825-8418; Fax: (310) 206-6039; E-mail: ZFZHANG@UCLA.EDU.

(0.09%; Ref. 12). In a house-to-house survey in Burma among 6000 villagers over the age of 15 years, five cases were diagnosed, with a prevalence of 0.83% (13). In an oral lesion survey in Malaysia among 11,707 adults over the age of 35 years, one case of erythroplakia was identified (14).

In the study of 58 cases of erythroplakia, the disease was found to be more common among people in their 50s and 60s (12). The risk factors for oral cancer such as chewing tobacco, smoking, and alcohol drinking are assumed to be associated with erythroplakia. In a recent case-series study, erythroplakia was associated with a high prevalence of *TP53* mutations (15). *TP53* mutations may be associated with tobacco exposure for oral cancer (16-17), which would possibly indicate that tobacco exposure may play an important role in the development of erythroplakia.

To our knowledge, there have not been any case-control studies focusing on chewing tobacco, smoking, drinking, and the risk of erythroplakia in the literature, although the risk factors for erythroplakia have been assumed to be similar to those of oral cancer. The purpose of this study is to examine the independent effects of major potential risk factors, such as chewing tobacco, cigarette smoking, and alcohol drinking, and to explore possible interactions between them.

### Subjects and Methods

**Study Population and Data Collection.** A randomized oral cancer screening trial is currently being conducted in Kerala, India, with the objective of evaluating the efficacy of oral visual inspection by trained health workers in preventing death from this cancer (18). The state of Kerala is located on the west coast of southern India with an area of approximately 38,900 km<sup>2</sup>. Kerala is an ideal place for the screening trial because of the high prevalence of chewing tobacco and smoking habits, with 59.1% of the population practicing at least one of the tobacco habits, and because of the high risk of oral cancer. Keeping the chewing tobacco in the lower groove of the mouth is a habit especially common in Kerala.

This case-control study was conducted within the framework of the intervention trial, using data from the intervention arm. A total of 59,894 subjects, ages  $\geq 35$ , resident in seven panchayaths or rural administrative structures (total resident population 172,567) were randomized to the intervention group to receive three rounds of screening at 3-year intervals. In the first round of intervention, 49,174 eligible subjects participated and were interviewed and screened in their homes by trained health workers. The 100 cases of erythroplakia and 47,773 controls in this study were identified from this group.

The health workers were required to be college graduates who were residents of the area. They were trained specifically in epidemiology, diagnosis, investigation, and management of oral precancers and cancers as described previously (18). The health workers conducted face-to-face interviews with a structured questionnaire. The subjects were asked about demographic information and their tobacco chewing, smoking, and alcohol drinking habits in terms of duration, frequency, and type of tobacco or alcohol used. For chewing tobacco, the subjects were also asked whether they kept the chewing tobacco in their mouth overnight and whether they swallowed the chewing tobacco fluid. Health workers asked whether fruits were taken frequently, vegetables were taken daily, and vitamins/iron supplements were taken currently or in the past. Their blood pressure, body weight, and height were measured. After this, the health workers conducted systematic visual inspections of the buccal and labial mucosa, gingivae, bucco alveolar sulci,

tongue, and palate and floor of the mouth, under adequate light to identify lesions suggestive of oral leukoplakia, erythroplakia, submucous fibrosis, and/or oral cancer, and then referred subjects with positive findings. Subjects with tobacco and alcohol habits were advised to stop these practices. Two dentists and three oncologists who used uniform criteria were involved in the final diagnosis of these oral premalignant lesions. Of the 3585 subjects referred, a little more than one-half were examined by dentists, and various lesions were confirmed. Erythroplakia cases were defined as subjects diagnosed with erythroplakia by the dentists ( $n = 100$ ). Controls were defined as subjects who were inspected by the health workers and diagnosed to be free of any oral condition or disease ( $n = 47,773$ ).

**Statistical Analysis.** The effects of chewing tobacco, smoking, and alcohol drinking on the risk of erythroplakia were estimated with ORs<sup>3</sup> and their 95% CIs, derived from logistic regression analysis. Continuous variables such as years of chewing, smoking, or drinking, and frequency of use were first analyzed as continuous variables and then were categorized into groups according to categories often used in previous studies. BMI was calculated by dividing the weight in kilograms by the height in meters squared. Dummy variables were created to estimate OR for each category of exposure in logistic regression analysis. Trend tests for ordered variables were performed by assigning the score  $j$  to the  $j$ th exposure level of a categorical variable (where  $j = 1, 2, \dots$ ) and treating it as a continuous predictor in unconditional logistic regression.

The distributions for age, sex, religion, occupation, and education were examined for cases and controls. The distributions differed greatly between cases and controls for age, sex, and education. BMI has been indicated as a potential risk factor for oral cancer (19). On the basis of these distributions and of prior knowledge of potential risk factors for oral premalignant lesions and oral cancer, we adjusted for age, sex, education, and BMI in our data analysis.

Three models were used to assess exposure effects: (a) no covariates (crude analysis); (b) statistical adjustment for age (continuous), sex (F/M), education (categorical, as shown in Table 1), and BMI (continuous, kg/m<sup>2</sup>); and (c) statistical adjustment for additional covariates, including chewing tobacco (continuous, duration in years), smoking (continuous, pack-years), and drinking (continuous, duration in years) in the logistic regression model where appropriate.

Stratified analysis was used to assess departures from additive and multiplicative effects among major potential risk factors, including tobacco chewing, cigarette smoking, alcohol drinking, low vegetable intake, and low fruit intake. The null hypotheses of additivity and multiplicativity were tested. A more than additive interaction is indicated when:  $OR_{11} > OR_{10} + OR_{01} - 1$ , where  $OR_{11} = OR$  when both factors are present,  $OR_{10} = OR$  when only factor 1 is present,  $OR_{01} = OR$  when only factor 2 is present. A more than multiplicative interaction is suggested when:  $OR_{11} > OR_{10} \times OR_{01}$  (20). Departures from multiplicative effects were assessed and tested by including main effects and a product term of the main effects in the logistic regression model.

### Results

The general characteristics of the erythroplakia cases and controls are shown in Table 1. The erythroplakia cases were con-

<sup>3</sup> The abbreviations used are: OR, odds ratio; CI, confidence interval; BMI, body mass index.

1916  
←

Table 1 General characteristics of the erythroplakia cases and controls

	Cases		Controls	
	n	%	n	%
Age groups				
<45 yr	20	20.0	18,748	39.2
45-54 yr	38	38.0	12,777	26.7
55-64 yr	35	35.0	9,804	20.5
≥65 yr	7	7.0	6,444	13.5
Sex				
Female	49	49.0	29,876	62.5
Male	51	51.0	17,897	37.5
Religion				
Hindu	52	52.0	32,968	69.0
Muslim	21	21.0	9,555	20.0
Christian	27	27.0	5,250	11.0
Occupation				
Manual	90	90.0	39,918	83.6
Teacher/Office worker	2	2.0	2,577	5.4
Business	2	2.0	1,227	2.6
Retired	4	4.0	2,801	5.9
Others	2	2.0	1,250	2.6
Education				
None and illiterate	39	39.0	8,351	17.5
None and literate	11	11.0	3,078	6.4
Primary	30	30.0	10,758	22.5
Middle	11	11.0	8,399	17.6
High School	8	8.0	12,788	26.8
Technical/College or Professional	1	1.0	4,390	9.2
Unknown	0	0.0	9	0.0

centrated in the older age groups, compared with the controls. The highest percentage of cases were in the 45-54-year age group, whereas the highest percentage of controls were in the <45-year age group. The percentage of females was 62.5% among controls but only 49.0% among the cases. For religion, there were a higher percentage of Hindus and lower percentage of Christians in the controls, compared with the cases. The distribution for occupation was similar in cases and controls; most had a manual occupation. For education, a higher percentage of cases were in the lower education groups than the controls, with 39.0% of cases and 17.5% of controls in the "none/illiterate" group.

The distribution of the chewing, smoking, and drinking habits were examined for cases and controls by sex (not presented). Current chewing habits were very high among both male cases (74.5%) and female cases (83.7%). The percentage of current chewers among female and male controls was approximately 20%. The prevalence of current smoking among women was low but was higher in the cases (8.2%) than the controls (1.8%). Smoking habits among men were slightly higher among cases (54.9%) than among controls (50.7%). The overall current smoking habit prevalence was 32.0% among cases and 20.1% among controls. Alcohol drinking was rare among women: 2.0% in cases and 0.2% in controls. For men, the prevalence of current drinking was 15.3% among controls and 39.2% among cases. The percentage of occasional drinkers was high among male controls (15.2%), whereas the percentage of past drinkers was high among male cases (27.5%). The overall drinking habit prevalence was 21.0% among cases and 5.8% among controls. Because drinking is not well accepted socially in India, underreporting may have occurred.

The ORs for chewing tobacco are shown in Table 2. The adjusted OR for ever-chewers was 19.8 (95% CI, 9.8-40.0)

after controlling for age, sex, education, BMI, pack-years of smoking, and years of alcohol drinking. The adjusted OR was highest for current chewers, followed by the OR for past chewers, and the OR for occasional chewers. A strong dose-response relationship was shown for the frequency (times per day; *P* for trend, 0.0001) and duration of tobacco chewing (years; *P* for trend, 0.0001) with the risk of erythroplakia. Chewers who swallowed chewing tobacco fluid had a higher adjusted OR than for chewers who did not swallow. Chewers who kept the chewing tobacco in the mouth overnight also had a higher adjusted OR than chewers who did not.

Table 3 shows the relationship between alcohol drinking and the risk of erythroplakia. The adjusted OR for ever-drinkers was 3.0 (95% CI, 1.6-5.7) when adjusted for age, sex, education, BMI, years of chewing, and pack-years of smoking. The adjusted ORs were highest for current drinkers, followed by those of past drinkers. No association was observed for occasional drinkers, but this category had only three erythroplakia cases. Dose-response relationships were suggested for both the frequency (times per day; *P* for trend, 0.0001) and duration of drinking (years; *P* for trend, 0.0001) on the risk of erythroplakia.

For cigarette smoking, the adjusted OR for ever-smokers was 1.6 (95% CI, 0.9-2.9) when adjusted for age, sex, education, BMI, years of chewing, and years of drinking (not presented). The adjusted OR for erythroplakia among occasional smokers (OR, 3.7; 95% CI, 1.5-9.6) was higher than for past smokers (OR, 1.6; 95% CI, 0.8-2.9), and for current smokers (OR, 1.1; 95% CI, 0.4-3.0), possibly because of misclassification of the exposure by the subjects or the small number of erythroplakia cases in the past and occasional categories. The adjusted OR for frequency of smoking (times per day) as a continuous variable was 1.02 (95% CI, 0.98-1.07). A dose-response relationship was shown in the crude analysis for the frequency of smoking and the risk of erythroplakia (*P* for trend, 0.0003), but when adjusted for various factors, the trend was no longer seen. The adjusted OR was 1.2 (95% CI, 0.6-2.4) for those who smoked 1-20 times per day and 2.3 (95% CI, 1.1-5.1) for those who smoked 21-40 times per day. For duration of smoking (years) as a continuous variable, the adjusted OR was 1.00 (95% CI, 0.99-1.02). Although a dose-response relationship was seen for years of smoking and the risk of erythroplakia in the crude analysis (*P* for trend, 0.0004), it was no longer apparent after adjusting for potential confounding factors.

Both vegetables and fruits showed potential protective effects against erythroplakia for the crude ORs (not presented). The adjusted ORs were 0.4 (95% CI, 0.3-0.7) for vegetable intake and 0.5 (95% CI, 0.3-0.9) for fruit intake after controlling for age, sex, education, and BMI. However, when further adjusted for chewing tobacco, smoking, and drinking, the CIs include the null value. Vitamins and iron supplements appeared to be risk factors for erythroplakia in the crude analysis and after controlling for age, sex, education, BMI (OR for current use, 1.9; 95% CI, 1.3-2.9) but no association was observed after further adjusting for chewing tobacco, smoking, and drinking (OR for current use, 1.4; 95% CI, 0.9-2.1). No obvious association was observed for BMI and risk of erythroplakia (*P* for trend, 0.7557) in the crude or adjusted logistic regression models (data not shown).

Table 4 shows the ORs for possible interactions between chewing, smoking, and drinking. For chewing and smoking, a slightly more than additive interaction was seen ( $OR_{11} > OR_{10} + OR_{01} - 1$ ;  $50.1 > 5.8 + 43.3 - 1$ ). However, when we estimated the adjusted ORs for tobacco chewing among smok-

Table 2 Chewing tobacco habits and risk of erythroplakia (ORs and 95% CIs)

	Cases	Controls	Crude OR (95% CI)	Adjusted OR* (95% CI)	Further adjusted OR <sup>†</sup> (95% CI)
<b>Chewing tobacco</b>					
No chewing	9	34,373	1.0	1.0	1.0
Ever chewing	91	13,400	25.9 (13.1-51.5)	20.6 (10.2-41.5)	19.8 (9.8-40.0)
<b>Chewing tobacco</b>					
No chewing	9	34,373	1.0	1.0	1.0
Past	10 <sup>‡</sup>	1,276	29.9 (12.1-13.5)	26.8 (13.1-54.7)	25.8 (12.6-52.8)
Occasional	2	2,625	2.9 (0.6-13.5)	2.4 (0.5-11.1)	2.3 (0.5-10.9)
Current	79	9,499	31.7 (15.9-63.3)	29.4 (11.6-74.6)	27.6 (10.8-70.4)
<b>Frequency of chewing (times per day)</b>					
Continuous					
No chewing	9	34,373	1.05 (1.03-1.07)	1.04 (1.02-1.06)	1.04 (1.02-1.06)
1-10	60	8,991	1.0	1.0	1.0
11-20	18	1,443	25.5 (12.6-51.4)	23.8 (11.5-49.3)	28.6 (14.0-58.7)
≥20	11	271	47.6 (21.4-106.2)	39.1 (17.0-90.1)	49.8 (22.0-113.1)
Missing	2	2,695	155.0 (63.7-377.1)	100.4 (39.3-256.8)	130.8 (52.5-326.3)
<i>P</i> for trend					
<b>Duration of chewing (yr)</b>			0.0001	0.0001	0.0001
Continuous					
No chewing	9	34,373	1.01 (0.99-1.02)	1.02 (1.00-1.04)	1.01 (0.99-1.03)
1-20	42	5,971	1.0	1.0	1.0
21-40	38	3,470	26.9 (13.1-55.2)	23.7 (11.3-49.6)	29.3 (14.2-60.8)
≥40	9	1,217	41.8 (20.2-86.6)	41.4 (19.0-90.1)	53.3 (24.7-114.8)
Missing	2	2,742	28.2 (11.2-71.3)	40.6 (14.0-117.4)	52.8 (18.3-152.6)
<i>P</i> for trend					
<b>Swallow chewing tobacco fluid</b>			0.0001	0.0001	0.0001
No chewing	9	34,373	1.0	1.0	1.0 <sup>‡</sup>
Chewing/no swallowing	77	10,117	29.1 (15.6-58.0)	26.6 (13.0-54.4)	20.8 (9.8-44.4)
Chewing/Swallowing	9	291	118.1 (46.6-299.7)	83.0 (31.5-218.6)	50.6 (17.9-143.4)
Occasionally swallow	3	303	37.8 (10.2-140.4)	23.2 (6.0-89.2)	14.5 (3.6-58.9)
Missing	2	2,689			
<b>Keep chewing tobacco in mouth overnight</b>					
No chewing	9	34,373	1.0	1.0	1.0 <sup>‡</sup>
Chewing/Don't keep	82	10,351	30.3 (15.2-60.2)	27.3 (13.4-55.8)	21.2 (10.0-45.2)
Chewing/Keep	7	310	86.2 (31.9-233.0)	64.6 (23.0-181.4)	36.3 (11.9-111.6)
Missing	2	2,687			

\* OR adjusted for age (continuous), sex (M/F), education (categories from Table 2), and BMI (continuous, kg/m<sup>2</sup>).  
<sup>†</sup> OR adjusted for age, sex, education, BMI, smoking (continuous, pack-years), and drinking (continuous, duration in years).  
<sup>‡</sup> OR adjusted for age, sex, education, BMI, smoking, drinking, and tobacco chewing (years and times per day).

ers and nonsmokers (not presented), the ORs were higher for nonsmokers (OR, 41.5; 95% CI, 12.5-137.6) than for smokers (OR, 8.0; 95% CI, 3.3, 19.4). Thus, there did not appear to be a positive effect modification for smoking and tobacco chewing. A more than additive interaction was seen for chewing and drinking (43.1 > 3.7 + 22.7 - 1), but when we estimated the adjusted ORs of tobacco chewing among drinkers and nondrinkers, the OR for nondrinkers was higher (OR, 24.9; 95% CI, 10.4-59.7) than for drinkers (OR, 9.8; 95% CI, 3.0-32.7). No obvious interaction was seen between drinking and smoking. The interactions for all of the three habits together could not be calculated because of the low number of total erythroplakia cases.

Several interactions were suggested for low fruit intake and low vegetable intake with tobacco and alcohol habits (not presented). A more than additive interaction between tobacco chewing and low vegetable intake was seen in regard to the risk of erythroplakia. The adjusted OR was 26.7 (95% CI, 11.4-62.5) for the main effect of tobacco chewing, 5.7 (95% CI, 1.4-23.2) for the main effect of low vegetable intake, and 33.5 (95% CI, 12.9-87.1) for the interaction. The risk of erythroplakia for subjects with low vegetable intake appeared to be much higher among tobacco chewers (adjusted OR, 25.5; 95% CI, 10.8-60.0) than among nonchewers (OR, 4.3; 95% CI, 1.3-16.2). There appeared to be a more than multiplicative

interaction between drinking and low fruit intake and between drinking and low vegetable intake. The adjusted OR was 2.3 (95% CI, 1.1-4.6) for the main effect of drinking, 0.8 (95% CI, 0.4-1.9) for the main effect of low fruit intake, and 4.4 (95% CI, 2.1-9.2) for the interaction. Low fruit intake was associated with a lower risk of erythroplakia among nondrinkers (OR, 0.9; 95% CI, 0.4-2.0) than among drinkers (OR, 1.5; 95% CI, 0.7-3.2), although the CIs overlapped between the two ORs. The adjusted OR was 2.2 (95% CI, 1.1-4.5) for the main effect of drinking, 1.0 (95% CI, 0.4-2.4) for the main effect of low vegetable intake, and 4.8 (95% CI, 2.3-9.9) for the interaction. The difference in the adjusted ORs between drinkers (OR, 1.0; 95% CI, 0.4-2.4) and nondrinkers (OR, 1.6; 95% CI, 0.8-3.7) was also small for low vegetable intake. Only potential interactions were suggested because the CIs of the main effects overlapped with the CIs of the interaction terms.

**Discussion**

Our results indicate that tobacco chewing is a strong risk factor for erythroplakia. Dose-response relationships were seen for the frequency of chewing tobacco with the risk of erythroplakia. Chewers who swallowed the tobacco fluid and chewers who kept the chewing tobacco in their mouths overnight both had higher risks for erythroplakia than chewers who did not swal-

1018  
 E

Table 3 Alcohol drinking habits and risk of erythroplakia (ORs and 95% CIs)

	Cases	Controls	Crude OR (95% CI)	Adjusted OR <sup>a</sup> (95% CI)	Further adjusted OR <sup>b</sup> (95% CI)
Alcohol drinking					
No drinking	62	40,801	1.0	1.0	1.0
Ever drinking	38	6,972	3.6 (2.4-5.4)	3.8 (2.1-7.1)	3.0 (1.6-5.7)
Alcohol drinking					
No drinking	62	40,801	1.0	1.0	1.0
Past	14	1,475	6.2 (3.5-11.2)	4.6 (2.3-9.2)	4.8 (2.4-9.7)
Occasional	3	2,743	0.7 (0.2-2.3)	1.0 (0.3-3.5)	0.9 (0.3-3.1)
Current	21	2,754	5.0 (3.1-8.2)	5.9 (2.8-12.4)	5.8 (2.7-12.5)
Frequency of drinking (days per week)					
Continuous			1.13 (0.96-1.34)	1.13 (0.96-1.34)	1.12 (0.95-1.33)
No drinking	62	40,801	1.0	1.0	1.0
1-2	4	659	4.0 (1.4-11.0)	4.2 (1.4-12.8)	3.9 (1.2-12.0)
3-5	10	1,474	4.5 (2.3-8.7)	4.1 (1.8-9.3)	4.3 (1.9-9.8)
6-7	21	1,986	7.0 (4.2-11.4)	6.4 (3.2-12.8)	6.7 (3.3-13.7)
Missing	3	2,853			
P for trend			0.0001	0.0001	0.0001
Duration of drinking (yr)					
Continuous			1.02 (1.00-1.05)	1.02 (0.99-1.06)	1.01 (0.97-1.04)
No drinking	62	40,801	1.0	1.0	1.0
1-10	4	988	2.7 (1.0-7.3)	2.8 (0.9-8.5)	2.7 (0.9-8.4)
11-20	7	1,330	3.5 (1.6-7.6)	3.4 (1.3-8.6)	3.7 (1.5-9.5)
21-30	14	1,016	9.1 (5.1-16.2)	8.3 (3.9-17.8)	8.9 (4.1-19.4)
>30	10	795	8.3 (4.2-16.2)	6.9 (3.0-16.0)	6.5 (2.7-15.7)
Missing	3	2,843			
P for trend			0.0001	0.0001	0.0001

<sup>a</sup> OR adjusted for age (continuous), sex (M/F), education (categories from Table 2), and BMI (continuous, kg/m<sup>2</sup>).

<sup>b</sup> OR adjusted for age, sex, education, BMI, smoking (continuous, pack-years), and chewing tobacco (continuous, duration in years).

Table 4 Risk of erythroplakia and interactions between chewing, smoking, and drinking

	Cases	Controls	Crude OR (95% CI)	Adjusted OR <sup>a</sup> (95% CI)	Further adjusted OR <sup>b</sup> (95% CI)
Chewing/Smoking					
No/No	3	26,731	1.0	1.0	1.0
No/Yes	6	7,642	7.0 (1.7-28.0)	5.6 (1.3-24.0)	5.8 (1.3-25.3)
Yes/No	54	8,836	54.5 (17.0-174.2)	43.0 (13.2-140.0)	43.3 (13.3-141.1)
Yes/Yes	37	4,564	72.2 (22.3-234.4)	53.6 (15.2-188.5)	50.1 (14.1-178.4)
Chewing/Drinking					
No/No	6	30,566	1.0	1.0	1.0
No/Yes	3	3,807	4.0 (1.0-16.1)	3.8 (0.9-16.3)	3.7 (0.9-16.1)
Yes/No	56	10,235	27.9 (12.0-64.7)	22.6 (9.6-53.5)	22.7 (9.6-53.7)
Yes/Yes	35	3,165	56.3 (23.7-134.0)	43.6 (16.4-116.1)	43.1 (16.1-115.3)
Drinking/Smoking					
No/No	48	34,472	1.0	1.0	1.0
No/Yes	14	6,329	1.6 (0.9-2.9)	2.2 (1.0-4.8)	2.1 (1.0-4.4)
Yes/No	9	1,095	5.9 (2.9-12.1)	8.1 (3.0-21.9)	4.8 (1.8-13.1)
Yes/Yes	29	5,877	3.5 (2.2-5.6)	5.9 (2.5-13.7)	4.7 (2.0-10.6)

<sup>a</sup> OR adjusted for age (continuous), sex (M/F), education (categories from Table 2), and BMI (continuous, kg/m<sup>2</sup>).

<sup>b</sup> In addition to the adjustment of age, sex, education, and BMI, for the model to assess the interactions between chewing and smoking, drinking was further adjusted; for the model to assess the interactions between chewing and drinking, smoking was further adjusted; for the model to assess the interactions between drinking and smoking, chewing was further adjusted.

low or keep the chewing tobacco fluid. Tobacco chewing has been reported as a risk factor for both oral leukoplakia and oral cancer. According to a previous study, the relative risk of oral cancer (tongue and floor of mouth) for tobacco chewers ( $\geq 10$  pan tobacco chewing/day) in Kerala, India was approximately 5.52 for males and 9.27 in females (2). In another study on oral cancers of the buccal and labial mucosa in Kerala, India, the relative risk for pan tobacco chewing was 16.36 for male subjects who had chewed more than 10 per day and was 14.24 for female subjects (3). The IARC concluded that there is sufficient evidence for the carcinogenicity of chewing betel quid containing tobacco for humans (21). For oral leukoplakia,

the risk for ever-tobacco-chewing was 3.80 in a study in Uzbekistan (22). Our results indicate that tobacco chewing is a stronger risk factor for erythroplakia in comparison with the effects for oral cancer and oral leukoplakia. This is the first time that a strong association between chewing tobacco and the risk of erythroplakia was found in a case-control study.

Alcohol drinking was also indicated as a strong risk factor for erythroplakia in our study. Dose-response relationships were shown for the frequency and duration of alcohol use with the risk of erythroplakia. Alcohol drinking has been associated with oral cancer as a risk factor and may be involved in a multiplicative interaction with smoking (23). Alcohol may pos-

sibly act as a solvent, allowing the carcinogens from tobacco to penetrate into the tissues or it may act as a catalyst in metabolically activating tobacco carcinogens (23). Another possible mechanism is that alcohol lessens the protective effect of vegetables and fruits by decreasing the nutrient intake or absorption (23). Our study did not show any obvious interactions between alcohol and tobacco habits, but an interaction between alcohol and nutrition was suggested for the risk of erythroplakia.

Smoking appears to be a weak risk factor for erythroplakia according to our results. Chewing tobacco may possibly be a stronger risk factor for erythroplakia than smoking in the Indian population, as is suggested for oral leukoplakia (24). Chewing tobacco may have a stronger effect than smoking because of the direct contact of the tobacco carcinogens with the oral epithelium as the chewing tobacco is chewed or kept in the mouth.

Fruit and vegetable intake showed potential protective effects, whereas vitamins and iron supplement intake seemed to show an increased risk for erythroplakia in the crude analysis and adjusted analysis controlling for age, sex, education, and BMI. BMI had no effect on the risk of erythroplakia. In our study, misclassification of fruit and vegetable intake may possibly have occurred because we did not define daily or frequent intake with specific amounts of intake. Fruit and vegetable intake may possibly help prevent erythroplakia or cause erythroplakia regression, similar to leukoplakia.

There are several possible limitations to this study. One limitation is the use of prevalent cases instead of incident cases. The OR may be overestimated if the prevalent cases may have had high levels of chewing, smoking, or drinking habits and less exposure to protective factors, which would lead to fewer patients regressing to a less severe lesion. On the other hand, the erythroplakia cases who did not progress to oral cancer and survived with the disease may be those subjects who had relatively healthier life-styles and weaker exposures to potential risk factors. In this case, the observed OR may have been underestimated. Another possibility is that the most severe cases may have been missed as they progressed to oral cancer.

Our study has potential for information bias. Perhaps some exposures were misclassified by the subjects during the interview because "occasional" and "past" use were not defined with specific frequency of use or with specific time periods. The possibility of recall bias may be small because the oral visual inspection was conducted and the final diagnosis was made after the interview. Moreover, the possibility of prior diagnosis of erythroplakia among cases is rather small. Another information bias was reporting bias. Drinking is not socially accepted in India, especially for women; thus, there may be an underestimation and misclassification of drinking habits. Because drinking may be associated with other potential risk factors, such as smoking and tobacco chewing, the misclassification may not necessarily be nondifferential between cases and controls. We have attempted to adjust for confounding by smoking and tobacco chewing by including these variables in the logistic regression models. However, there is still a possibility for residual confounding effects by other variables.

Detection bias is possible because the health workers knew the exposure status of the subjects and may have looked harder for oral lesions in subjects with high exposures to chewing tobacco, smoking, or alcohol drinking. In this situation, subjects who are actually controls may be misclassified as cases. The health workers may also have missed cases in the low- or no-exposure groups, leading to cases being diagnosed as controls. Detection bias may have led to an overestimation of the

risk. However, the subjects with oral lesions were also examined by dentists or oncologists who did not know the exposure status; thus, the misclassification of controls as cases may be minimized. The cases who may have been misdiagnosed as controls would not be examined by the dentists or oncologists, making it difficult to control such misclassification in this study.

Another limitation is the small sample size of cases, which may lead to few cases in certain categories, resulting in imprecision of estimates. In our analysis, some of the exposure categories had only a few cases. For the interactions of drinking with low fruit intake and with low vegetable intake, at least one of the cells had a small number of cases ( $n \leq 6$ ). The small number of cases in some of the cells may have limited our ability to estimate the OR precisely. However, the power of the study may have been compensated for by a very large sample of controls. To our knowledge, this study has one of the largest samples of erythroplakia cases ever studied in the literature. Moreover, the cases included in this study were derived from a well-defined population, which permits a generalization of results, provided that bias is minimized.

In conclusion, this is the first epidemiological study investigating the relationships between chewing tobacco, smoking, alcohol drinking, and the risk of erythroplakia. Our results indicate that chewing tobacco and drinking alcohol are strong risk factors for erythroplakia, whereas vegetable and fruit intake are possibly protective against erythroplakia. There was a suggestion of a more than additive interaction between tobacco chewing and low vegetable intake, and more than multiplicative interactions between low vegetable intake and drinking, and between low fruit intake and drinking.

## References

1. Sankaranarayanan, R., Duffy, S. W., Padmakumary, G., Day, N. E., and Padmanabhan, T. K. Tobacco chewing, alcohol and nasal snuff in cancer of the gingiva in Kerala, India. *Br. J. Cancer*, 60: 638-643, 1989.
2. Sankaranarayanan, R., Duffy, S. W., Day, N. E., Nair, M. K., and Padmakumary, G. A case-control investigation of cancer of the oral tongue and the floor of the mouth in southern India. *Int. J. Cancer*, 44: 617-621, 1989.
3. Sankaranarayanan, R., Duffy, S. W., Padmakumary, G., Day, N. E., and Krishan, N. M. Risk factors for cancer of the buccal and labial mucosa in Kerala, southern India. *J. Epidemiol. Community Health*, 44: 286-292, 1990.
4. Roed-Petersen, B. Effect on oral leukoplakia of reducing or ceasing tobacco smoking. *Acta Dermato-Venerol.*, 62: 164-167, 1982.
5. Stich, H. F., Hornby, A. P., Mathew, B., Sankaranarayanan, R., and Nair, M. K. Response of oral leukoplakias to the administration of vitamin A. *Cancer Lett.*, 40: 93-101, 1988.
6. Stich, H. F., Rosin, M. P., Hornby, A. P., Mathew, B., Sankaranarayanan, R., and Nair, M. K. Remission of oral leukoplakias and micronuclei in tobacco/betel quid chewers treated with  $\beta$ -carotene and with  $\beta$ -carotene plus vitamin A. *Int. J. Cancer*, 42: 195-199, 1988.
7. Sankaranarayanan, R., Mathew, B., Varghese, C., Sudhakaran, P. R., Menon, V., Jayadeep, A., Nair, M. K., Mathews, C., Manalingam, T. R., Balaram, P., and Nair, P. P. Chemoprevention of oral leukoplakia with vitamin A and  $\beta$ -carotene: an assessment. *Oral Oncol.*, 33: 231-236, 1997.
8. Kramer, I. R., Lucas, R. B., Pindborg, J. J., and Sobin, L. H. Definition of leukoplakia and related lesions: an aid to studies on oral precancer. *Oral Surg Oral Med. Oral Pathol.*, 46: 518-539, 1978.
9. Bouquet, J. E. Oral leukoplakia and erythroplakia: a review and update. *Pract. Periodontics Aesthet. Dent.*, 6: 9-17, 1994.
10. Bouquet, J. E., and Whitaker, S. B. Oral leukoplakia—rationale for diagnosis and prognosis of its clinical subtypes or "phases". *Quintessence Int.*, 25: 133-140, 1994.
11. Bouquet, J. E., and Ephros, H. Erythroplakia: the dangerous red mucosa. *Pract. Periodontics Aesthet. Dent.*, 7: 59-67, 1995.
12. Shafer, W. G., and Waldron, C. A. Erythroplakia of the oral cavity. *Cancer (Phila.)*, 36: 1021-1028, 1975.
13. Lay, K. M., Sein, K., Myint, A., Ko, S. K., Pindborg, J. J. Epidemiologic study of 600 villagers of oral precancerous lesions in Bilugyun: preliminary report. *Commun. Dent. Oral Epidemiol.*, 10: 152-155, 1982.

14. Zain, R. B., Ikeda, N., Razak, I. A., Axell, T., Majid, Z. A., Gupta, P. C., and Yaacob, M. A national epidemiological survey of oral mucosal lesions in Malaysia. *Commun. Dent. Oral Epidemiol.*, 25: 377-383, 1997.
15. Qin, G. Z., Park, J. Y., Chen, S. Y., and Lazarus, P. A high prevalence of p53 mutations in pre-malignant oral erythroplakia. *Int. J. Cancer*, 80: 345-348, 1999.
16. Chiang, C. P., Huang, J. S., Wang, J. T., Chiang, C. P., Huang, J. S., Wang, J. T., Liu, B. Y., Kuo, Y. S., Hahn, L. J., and Kuo, M. Y. Expression of p53 protein correlates with decreased survival in patients with areca quid chewing and smoking-associated oral squamous cell carcinomas in Taiwan. *J. Oral Pathol. Med.*, 28: 72-76, 1999.
17. Koch, W. M., Lango, M., Sewell, D., Zahurak, M., and Sidransky, D. Head and neck cancer in nonsmokers: a distinct clinical and molecular entity. *Laryngoscope*, 109: 1544-1551, 1999.
18. Sankaranarayan, R., Mathew, B., Jacob, B. J., Thomas, G., Somanathan, T., Pisani, P., Pandey, M., Ramadas, K., Najeeb, K., and Abraham, E. Early findings from a community-based, cluster-randomized, controlled oral cancer screening trial in Kerala, India. The Trivandrum Oral Cancer Screening Study Group. *Cancer (Phila.)*, 88: 664-673, 2000.
19. Kabat, G. C., Chang, C. J., Wynder, E. L. The role of tobacco, alcohol use, and body mass index in oral and pharyngeal cancer. *Int. J. Epidemiol.*, 23: 1137-1144, 1994.
20. Kleinbaum, D. G., Kupper, L. L., Morgenstern, H. *Epidemiologic Research: Principles and Quantitative Methods*. London: Lifetime Learning Publications, 1982.
21. Tobacco habits other than smoking; betel-quid and areca-nut chewing; and some related nitrosamines. IARC Working Group, Lyon, 23-30 October 1984. IARC Monogr. Eval. Carcinog. Risk Chem. Hum., 37: 1-268, 1985.
22. Evstifeeva, T. V., and Zaridze, D. G. Nass use, cigarette smoking, alcohol consumption and risk of oral and oesophageal precancer. *Eur. J. Cancer B Oral Oncol.*, 28B: 29-35, 1992.
23. Blot, W. J. Alcohol and cancer. *Cancer Res.*, 52 (Suppl.): 2119s-2123s, 1992.
24. Mehta, F. S., Gupta, P. C., and Pindborg, J. J. Chewing and smoking habits in relation to precancer and oral cancer. *J. Cancer Res. Clin. Oncol.*, 99: 35-39, 1981.

J Oral Pathol Med. 1998 Nov;27(10):475-9.

## Role of chewing and smoking habits in the etiology of oral submucous fibrosis (OSF): a case-control study.

Shah N, Sharma PP.

Department of Dental Surgery, All India Institute of Medical Sciences, New Delhi.

### **Abstract**

Oral submucous fibrosis (OSF), a premalignant and crippling condition of the oral mucous membrane, was studied to identify its relationship to various chewing and smoking habits. Two hundred and thirty-six consecutive cases of OSF were compared with 221 control subjects matched for age, sex and socio-economic conditions. It was found that chewing of areca nut/quid or pan masala (a commercial preparation of areca nuts, lime, catechu and undisclosed colouring, flavouring and sweetening agents) was directly related to OSF. Also, pan masala was chewed by a comparatively younger age group and was associated with OSF changes earlier than areca nut/quid chewing. However, chewing or smoking tobacco with various other chewing habits did not increase the risk of developing OSF. It was also found that frequency of chewing rather than the total duration of the habit was directly correlated to OSF.

J Oral Pathol Med. 2004 May;33(5):274-7.

### Oral submucous fibrosis: a case-control study in Chennai, South India.

Ranganathan K, Devi MU, Joshua E, Kirankumar K, Saraswathi TR.

Department of Oral Pathology, Ragas Dental College and Hospital, Chennai, India. ran2@vsnl.com

Comment in: Evid Based Dent. 2006;7(3):79-80.

#### **Abstract**

**BACKGROUND:** Oral submucous fibrosis (OSF) is a pre-cancerous condition caused by the use of areca nut in various forms. There are very few published reports on areca nut use and OSF from Chennai, South India.

**METHODS:** A hospital-based case-control study on habits and OSF was performed in Chennai over a 3-year period. A total of 185 consecutive patients with OSF were matched with age- and sex-matched controls. History was recorded in a pre-determined format by qualified dental surgeons.

**RESULTS:** The male to female ratio of OSF cases was 9.9 : 1. All areca nut products were associated with OSF, with the risk being greatest for pan masala. The duration of the habit was more significant than the frequency of the chewing habit.

**CONCLUSION:** The present study confirms the strong association between areca nut use and OSF and the increasing use of pan masala.

# Head & Neck Oncology

Research

Open Access

## Correlation of histopathological diagnosis with habits and clinical findings in oral submucous fibrosis

Shruti Pandya<sup>1</sup>, Ajay Kumar Chaudhary<sup>3</sup>, Mamta Singh<sup>1</sup>, Mangal Singh<sup>2</sup> and Ravi Mehrotra\*<sup>1</sup>

Address: <sup>1</sup>Departments of Pathology, Moti Lal Nehru Medical College, Allahabad, India, <sup>2</sup>Otorhinolayngology, Moti Lal Nehru Medical College, Allahabad, India and <sup>3</sup>Centre for Biotechnology, University of Allahabad, India

Email: Shruti Pandya - shrutigentech@gmail.com; Ajay Kumar Chaudhary - ajaygenome@gmail.com; Mamta Singh - mrspath25@gmail.com; Mangal Singh - mangalsingh@yahoo.co.in; Ravi Mehrotra\* - rm8509@gmail.com

\* Corresponding author

Published: 2 May 2009

Received: 26 March 2009

Head & Neck Oncology 2009, 1:10 doi:10.1186/1758-3284-1-10

Accepted: 2 May 2009

This article is available from: <http://www.headandneckoncology.org/content/1/1/10>

© 2009 Pandya et al; licensee BioMed Central Ltd.

This is an Open Access article distributed under the terms of the Creative Commons Attribution License (<http://creativecommons.org/licenses/by/2.0>), which permits unrestricted use, distribution, and reproduction in any medium, provided the original work is properly cited.

### Abstract

**Background:** Oral submucous fibrosis is a common oral health problem in India. This study was conducted to correlate the histopathological diagnosis with habits and clinical findings in patients suffering from oral submucous fibrosis (OSF).

**Methods:** Patients suffering from oral submucous fibrosis from the Departments of Otorhinolayngology and Pathology, Moti Lal Nehru Medical College, Allahabad, India were studied from 2004–2008. Detailed information was gathered in a pretested proforma. Emphasis was given to the various addictions, clinical findings and histological examination was done.

**Results:** Two hundred and thirty nine patients were studied, yielding a male to female ratio of 6.8:1. Maximum patients were in the 21–30 years age group with a marked male predominance. Of these, 197 (82.4%) patients chewed areca nut/dohra, 14 (5.8%) were smokers and 2 (0.8%) patients were habituated to alcohol. 89(37.2%) patients reported difficulty in opening of the mouth (trismus). 51 (57.4%) patients were found to have stage II (2–3 cm) trismus while rest had stage I and III. The buccal mucosa was found to be the most commonly involved site. On the basis of histopathological examination, 52(21.7%) were classified as OSF grade I, 75(31.3%) patients as grade II and 112(46.8%) had grade III disease.

**Conclusion:** The widespread habit of chewing dohra/paan masala is a major risk factor of OSF, especially in the younger age group. In this study, an increase in histopathological grading was found with severity and duration of addiction habit. However no significant correlation was found between clinical staging and histopathological grading.

### Background

Oral submucous fibrosis (OSF) is a chronic and potentially malignant condition of the oral cavity. It is characterized by a juxtraepithelial inflammatory reaction

followed by fibroelastic changes in the lamina propria and associated epithelial atrophy. The disease affects most part of the oral cavity as well as the upper third of the esophagus. [1]

1024  
J

The pathogenesis of OSF is not well established, but is believed to be multifactorial. The chewing of betel quid (containing areca nut, tobacco and slaked lime) has been recognized as one of the most important risk factors for OSF. [2-4] Over the years, the incidence of OSF has increased manifold in various parts of the Indian subcontinent including Allahabad. [5]

In spite of the fact that the habit of areca nut chewing with or without betel quid is rampant, the correlation between the extent and duration of addictions with clinical and histopathological grading has not been attempted so far. Thus, this study was designed investigate to these issues.

**Methods**

Patients suffering from OSF from the Departments of Otorhinolayngology and Pathology, Moti Lal Nehru Medical College, Allahabad were studied from 2004-2008, after obtaining clearance from the institutional ethical committee. Detailed information of each patient was noted in a pretested proforma. Information regarding the patients' name, age, sex, occupation, background, dietary habits, dental hygiene, personal habits and present complaints was gathered. Emphasis was given to addictions like areca nut, tobacco and alcohol. Detailed clinical examination of each patient was done to assess the site, size and type of lesion. Trismus was classified as stage I (> 3 cm), stage II (2-3 cm) and stage III (<2 cm). For confirmation of the clinical diagnosis, histopathological examination was carried out. The biopsy tissue was processed by paraffin embedding and 2-3 micrometer thick sections were cut and stained by Haematoxylin and eosin (H and E). Histopathological examination was done and results were recorded according to the traditional grading by Pindborg and Sirsat. [6] who had described four consecutive stages (Table 1)

**Results**

Two hundred and thirty nine OSF patients were studied, of which 204(85.4%) were males and 35(14.6%) females

with a male to female ratio of 6.8:1. Maximum number of patients, 109(45.6%) were in the 21-30 years age group followed by 67 (28%) patients in the 31-40 years of age [Figure 1].

According to their personal habits, 110(46%) patients chewed areca nut/dohra, 49 (20.5%) patients consumed gutka, 38 (15.8%) patients were habituated to smoking, 11(4.6%) chewed and smoked, 7 (2.9%) patients were addicted to alcohol and chewing. 7 (2.9%) patients were addicted to alcohol and smoking and 2 patients were addicted only to alcohol [Table 2].

With regard to site distribution, the buccal mucosa was the most common involved site with 66(20.8%) patients being involved. Palate was the second common site and affected 37(17.7%) patients. Both buccal mucosa and the palate were involved in 19(7.9%) patients. Buccal mucosa with the retro molar area involvement was found in 27 (3.1%) patients [Figure 2].

On the basis of clinical symptoms, 89(37.2%) patients reported difficulty in opening of the mouth, 62(25.9%) patients suffered from a burning sensation of the buccal cavity, 54(22.5%) patients reported excessive salivation and 34(14.2%) patients reported recurrent oral ulcerations [Figure 3].

On correlating the histopathological findings with the patients' addiction habits, 52 (21.7%) had OSF grade I, of which 20(38.5%) chewed paan masala/dohra, 10 (19.2%) took only gutka, 7(13.5%) consumed betel quid with areca nut and tobacco, 5 (11.1%) were smokers, 5 (9.6%) patients were both chewers and smokers, 3 (5.8%) were addicted to alcohol and chewing, while 2 (3.6%) were habituated to alcohol and smoking. On correlating histopathological findings with frequency and duration of addiction in OSF grade I, maximum patients were addicted for at least 3-5 years and used tobacco products 4-5 times per day.

**Table 1: Histopathological classification of OSF**

Very early stage (Grade I):	Early stage (Grade II):	Moderately advanced stage (Grade III):	Advanced stage (Grade IV):
<ul style="list-style-type: none"> <li>❖ A finely fibrillar collagen, dispersed with marked edema.</li> <li>❖ The fibroblastic response is strong.</li> <li>❖ The blood vessels are sometimes normal, but more often they are dilated and congested.</li> <li>❖ Inflammatory cells, mainly polymorphonuclear leukocytes with an occasional eosinophil are present.</li> </ul>	<ul style="list-style-type: none"> <li>❖ The juxta-epithelial area shows early hyalinization.</li> <li>❖ Plump young fibroblasts are present in moderate numbers.</li> <li>❖ The blood vessels are dilated and congested.</li> <li>❖ The inflammatory cells are mostly mononuclear lymphocytes, eosinophils and an occasional plasma cell.</li> </ul>	<ul style="list-style-type: none"> <li>❖ The collagen is moderately hyalinized.</li> <li>❖ The fibroblastic response is less marked, the cells present being mostly adult fibrocytes.</li> <li>❖ Blood vessels are normal or constricted.</li> <li>❖ The inflammatory exudates consist of lymphocytes and plasma cells, although an occasional eosinophil is seen.</li> </ul>	<ul style="list-style-type: none"> <li>❖ The collagen is completely hyalinized.</li> <li>❖ The hyalinized areas are devoid of fibroblasts.</li> <li>❖ Blood vessels are completely obliterated or narrowed.</li> <li>❖ The inflammatory cells are lymphocytes and plasma cells.</li> </ul>

1025  

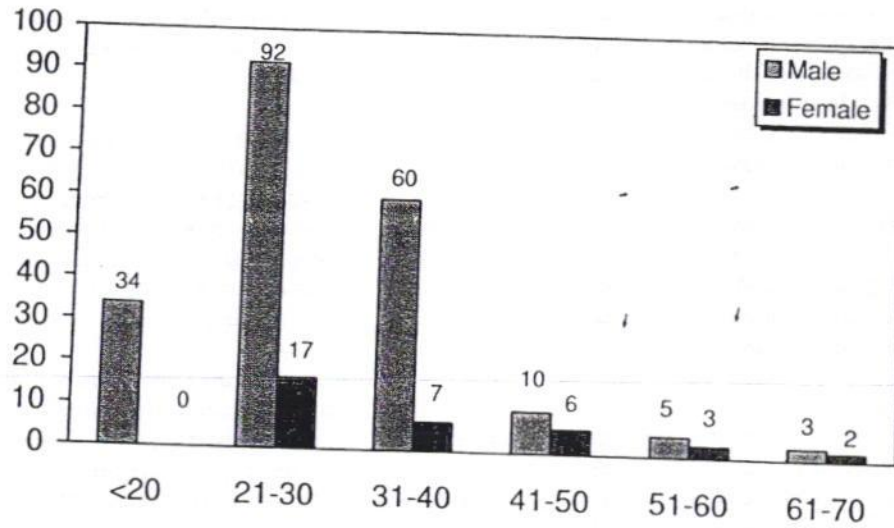
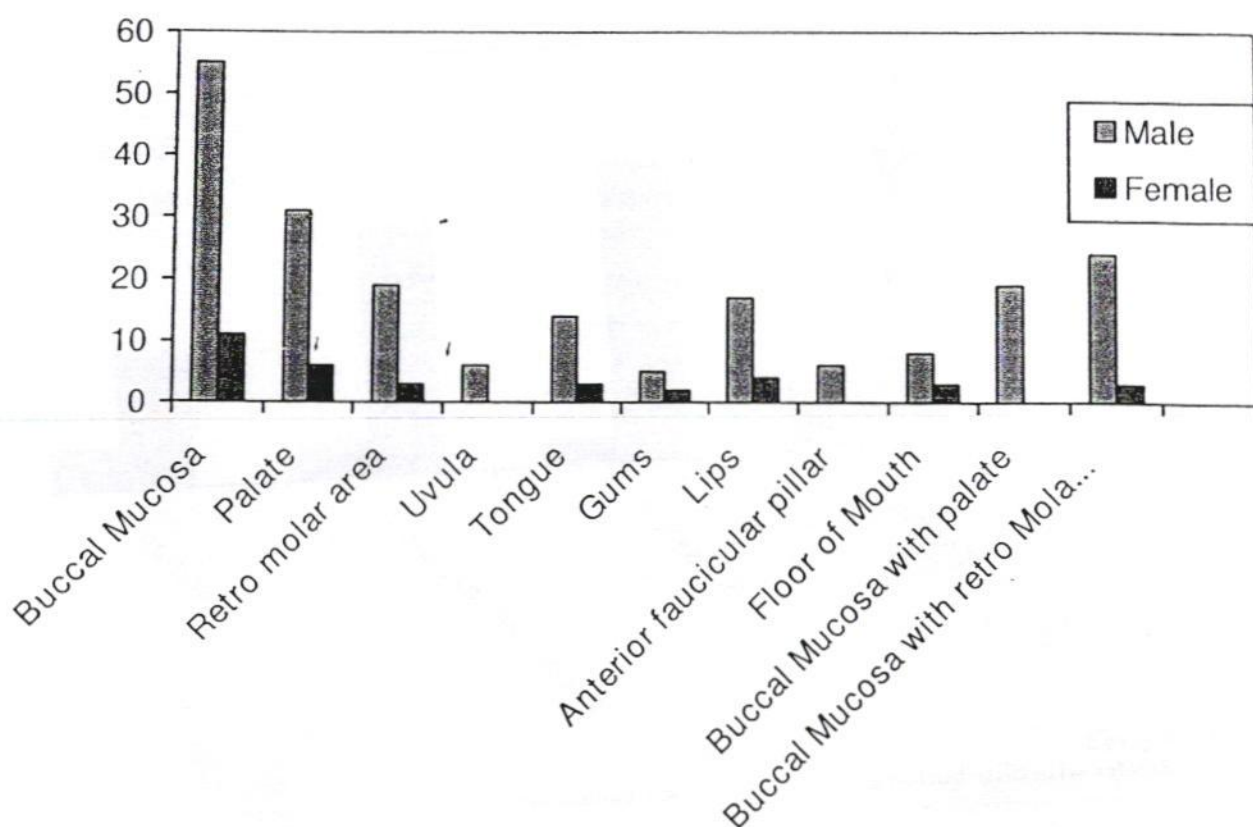

**Figure 1**  
Distribution of 239 cases of OSF according to age & sex.

**Table 2: Distribution of patients on their personal habits**

Personal Habits	No. of Patients	Total	
Chewing	(Areca Nut/Dohra)	110 (46%)	197(82.4%)
	Gutka	49 (20.5%)	
	Betel quid with areca nut and tobacco	38 (15.8%)	
Smoking	Bidi/Cigarettes/Pipes	14 (5.9%)	14 (5.9%)
Alcohol		2 (0.8%)	2 (0.8%)
Combination	Chewing + Smoking	11 (4.6%)	25 (10.4%)
	Alcohol+ Chewing	7 (2.9%)	
	Alcohol+ Smoking	7 (2.9%)	
None		1 (0.4%)	
<b>Total</b>		<b>239</b>	

1026



**Figure 2**  
Sites of fibrosis.

In OSF grade II category, out of 75(31.3%) patients, 30 (40%) chewed paan masala/dohra, 16(21.3%) were habituated to gutka, 11 (14.7%) took betel quid along with areca nut and tobacco, 6(8%) smoked bidi/cigarettes [Figure 4]. Four (5.3%) patients chewed and smoked tobacco, 3(4%) were addicted to chewing and alcohol and another 3 (4%) were addicted to alcohol and smoking. One patient was addicted to alcohol and 1 patient did not have any habit. In this group, maximum patients were addicted for 7-10 years and daily consumed the substances 4-8 times per day.

One hundred and twelve (46.8%) patients had histopathological grade III disease and of these 60 (53.5%) chewed paan masala/dohra, 23 (20.4%) were habituated to gutka, 20 (18%) consumed betel quid with areca nut and tobacco, 3(2.7%) were smokers, 2 (1.8%) both chewed and smoked, 2 (1.8%) were addicted to alcohol and smoking, 1(0.9%) consumed alcohol and chewed tobacco and 1(0.9%) was addicted to alcohol. Majority of patients of this group consumed tobacco products for 8-

10 years or more with a frequency of 6-10 times per day [Table 3, Figure 5].

On correlating clinical grading of trismus and histopathological grading, patients who had clinical stage I trismus 3(16.6%) patients had grade I, 5(17.2%) had grade II and 8 (19%) had grade III. In stage II trismus group, 11(61.1%) patients had grade I and 17(58.6%) had grade II and 23(54.7%) had grade III. While in stage III trismus, 4 (22.2%) patients had grade I, 7 (24.1%) had grade II and 11(26.1%) had grade III. [Table 4]

**Discussion**

OSF is a potentially malignant disease of oral cavity and is most commonly found in Asian countries. Reichart et al suggested that as a result of transmigration of populations, an increasing number of OSF cases are being found in other countries. [7] It constitutes one of the major oral health problems in countries like India. In this study, 239 OSF patients were studied over a 4-year period. Majority of the patients were in the 21-30 years of age group with a male to female ratio 6.8:1. Kumar et al found similar

1027  
8

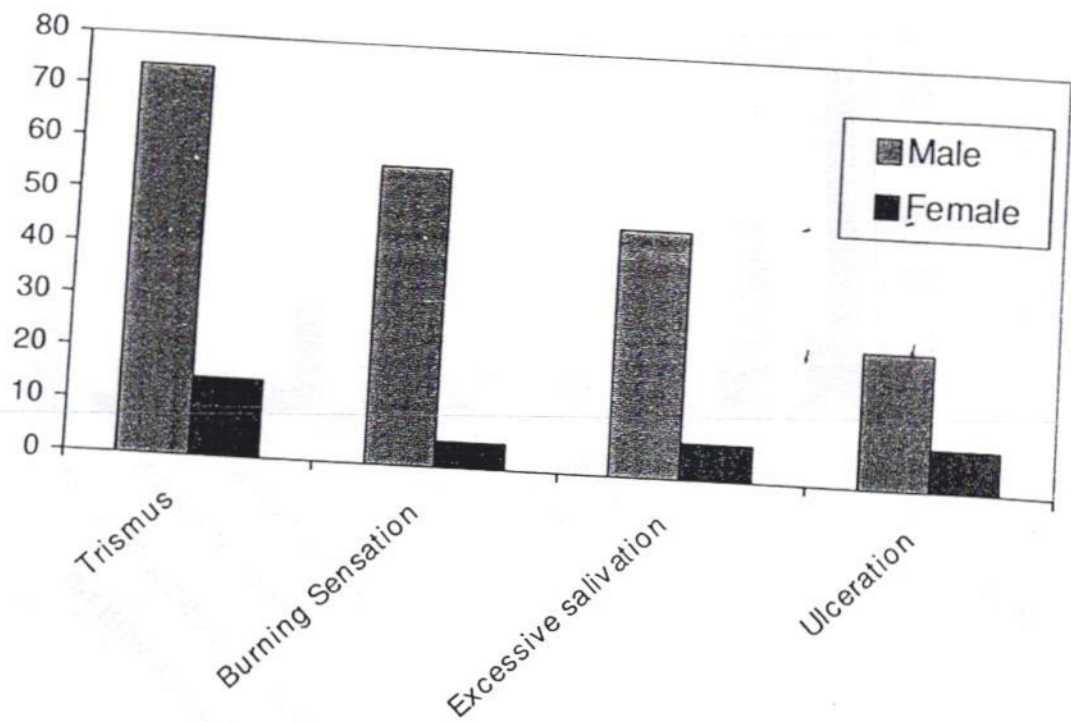

**Figure 3**  
Gender wise distribution of patients with their clinical symptoms.

results from Chennai. [8] Hazarey et al from Nagpur also reported that most of their patients were in the younger age group (< 30 years) with a similar male to female ratio of 5:1. [9] However, Zhang et al from China suggested that the prevalence of betel quid chewing is highest in the Hunan and Hainan provinces (64.5% to 82.7%) with signs of OSF in 0.9% to 4.7% of the population and the 30 to 49 years age group being the most commonly affected [10]

Areca nut, incriminated in the causation of OSF is often wrapped in the leaf of a tropical creeper, *Piper betle* L. commonly known as the betel leaf or paan [Figure 6]. The usage of paan is widespread in the Indian subcontinent, mostly in the Hindi speaking heartland of North and Central India.

In the Allahabad region, consumption of a unique preparation called dohra is widespread. [11] It is popular in the district as well as neighbouring regions of Jaunpur and Pratapgarh. It is a mixture of tobacco, slaked lime, areca nut and other ingredients like catechu (*katha*), peppermint and cardomom (*illayachi*) etc. It is a wet preparation and marketed without any brand name. About 200 mg product is kept in plastic bag and a rubber band is applied.

One packet is sold for as less as one rupee (approx two US cents). Users consume tobacco (Surti/Zarda) with dohra according to their level of addiction. In this study, 110 (46%) patients, chewed paan masala/dohra. On the other hand, Kumar et al reported from Chennai that 81% of their patient's had the habit of chewing raw areca nut/commercial areca nut/paan masala. [8] Hazarey et al reported in their study from Nagpur in Western India that areca nut in its pure form was more commonly consumed by women while Khara/Mawa, the common name of gutka (combination of areca nut, paan masala and tobacco) in that region, was usually consumed by men. [9] Babu et al reported that habitual chewing of paan masala/gutka is associated with earlier presentation of oral submucous fibrosis than betel quid use. [12] Thomas et al from South India suggested tobacco chewing was the most important risk factor for multiple oral premalignant lesions and may be a major etiological factor for cancers on the oral epithelium in the Indian population. [13]

In this study, 38 (15.8%) patients were addicted to betel quid with areca nut and tobacco. 14 (5.9%) males were addicted to smoking alone. Only 2 (0.8%) males were habituated to alcohol, but no consistent correlation was found between the OSF and smoking/alcohol consump-

1028  
h

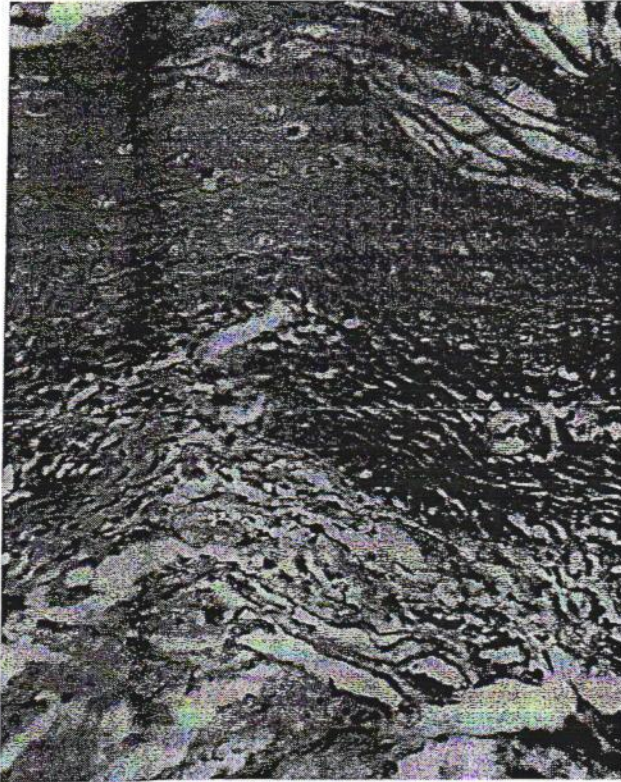

**Figure 4**  
**Oral mucosa showing OSF grade II demonstrating fibroblasts in the juxta-epithelial area with dilated blood vessels (H and E  $\times 100$ ).**

tion. Ho et al reported a significant contribution of smoking and alcohol consumption to the malignant transformation of OSF [14]. However, combination of alcohol, chewing and smoking was comparatively more dangerous, 25 (10.4%) patients were addicted to combination of chewing, smoking and alcohol. Similarly, Auluck et al reported from immigrant population in Canada that smoking and alcohol drinking along with areca quid chewing showed a significant association with leukoplakia, OSF and verrucous lesions. [15]

Buccal mucosa was found the most commonly involved site in 66 (20.8%) patients followed by palate 37 (17.7%) and the retromolar area 22 (14.7%). Previous reports also corroborated these findings. [9,14,15] Bhugari et al from Pakistan also reported that mucosa of the cheek (55.9%) was the most common site followed by the tongue (28.4%) [16]. While Reichart and Way reported the tongue was the most common site, in their study. [17] In this series, none of the patients were reported with involvement of the larynx, pharynx or the esophagus.

Clinically, trismus (opening of the mouth cavity) is an important symptom of OSF. In this study, 89 (37.2%) patients were found to have trismus of which, 16 (17.9%) had stage I, 51 (57.3%) patients had stage II trismus followed by 22 (24.7%) of stage III. Chiu et al reported the trismus was the chief complaint in 90.8% of their patients. [18] Kumar et al also reported that 75% males and 80% females with OSF patients had stage II disease and suggested that this could be due to the fact that the majority of the patients reported for treatment only after the onset of restriction in their ability to open their mouths. [8] Hazarey et al also reported that maximum patients of OSF, in their study, had stage III trismus. [9]

On the correlation of addiction habit and histopathological findings, maximum patients had histopathological grade III OSF and took tobacco products for 8–10 years or more with high frequency (7–10 times per day) followed by histopathological grade II and I. Kumar et al suggested the patients who used paan masala with a greater frequency/day developed OSF with a shorter duration of the habit. [8] Maher et al from Pakistan reported that the daily consumption rate appears to be much more significant with respect to risk than the lifelong duration of the habit. [19] Some reports suggested that both the duration and daily frequency of areca nut use increase the risk of cancer, suggesting a dose-response relationship. [20] Similarly, Shah et al reported that the total duration of the chewing habit was not significantly correlated to OSF. They hypothesized that the exposure to the total burden of various harmful substances in a given period, *i.e.*, daily consumption was more significant than the total duration of the habit. [21] No correlation was found between clinical grading and histopathological grading in this study akin to Kumar et al who did not find any correlation between clinical symptoms and degree of fibrosis. [8]

The treatment of patients with oral submucous fibrosis depends on the degree of clinical involvement. If the disease is detected at a very early stage, cessation of the habit is sufficient. Most patients with oral submucous fibrosis present with moderate-to-severe disease. Medical treatment is symptomatic and predominantly aimed at improving mouth movements. Treatment strategies include the following: Steroids, Placental extracts [22], Hyaluronidase, Pentoxifylline [23], IFN-gamma [24] and Lycopene [25].

Surgical treatment is indicated in patients with severe trismus and/or biopsy results revealing dysplastic or neoplastic changes. Surgical modalities that have been used include simple excision of the fibrous bands, Split-thickness skin grafting, Nasolabial flaps and lingual pedicle flaps. Use of a KTP-532 laser release procedure was recently found to increase mouth opening range in 9

1030

**Table 3: Distribution of patients with their Histopathological findings and habits**

Histological Findings	No of patients N = 239	Habits	No of Patients	Sex		Frequency/Day	Duration (Years)		
				Male N = 204	Female N = 35				
OSMF I	52 (21.8%)	Chewing (Areca Nut/Dohra)	20 (38.5%)	17 (85%)	3 (15%)	3-4	3-4 yrs		
		Gutka	10 (19.2%)	9 (90%)	1 (10%)	2-3	2-4 yrs		
		Betel quid with areca nut and tobacco	7 (13.5%)	4 (57.2%)	3 (42.8%)	2-4	4-5 yrs		
		Smoking (Bidi/Cigarettes/Pipes)	5 (11.1%)	5 (100%)	0 (0%)	5-10	>5 yrs		
		Alcohol	0 (0%)	0 (0%)	0 (0%)	0	0		
		Chewing + Smoking	5 (9.6%)	4 (80%)	1 (20%)	2-5/	3-4 yrs		
		Alcohol+ Chewing	3 (5.8%)	3 (100%)	0 (0%)	1-3	2-3 yrs		
		Alcohol+ Smoking	2 (3.6%)	2 (100%)	0 (0%)	2-5	4-5 yrs		
		OSMF II	75 (31.4%)	Chewing (Areca Nut/Dohra)	30 (40%)	24 (80%)	6 (20%)	7-10	8-10 yrs
				Gutka	16 (21.3%)	11 (68.8%)	5 (31.2%)	5-6	7-10 yrs
Betel quid with areca nut and tobacco	11 (14.7%)			7 (63.7%)	4 (36.3%)	6-9	6-7 yrs		
Smoking (Bidi/Cigarettes/Pipes)	6 (8%)			6 (100%)	0 (0%)	8-10	7-9 yrs		

Table 3: Distribution of patients with their Histopathological findings and habits (Continued)

		Alcohol	1 (1.3%)	1 (100%)	0 (0%)	2-3	6-7
		Chewing + Smoking	4 (5.3%)	3 (75%)	1 (25%)	4-8	6-8 yrs
		Alcohol+ Chewing	3 (4%)	3 (100%)	0 (0%)	3-8	7-10 yrs
		Alcohol+ Smoking	3 (4%)	3 (100%)	0 (0%)	4-7	8-10 yrs
		None	1 (1.4%)	1 (100%)	0 (0%)		
OSMF III	112 (46.8%)	Chewing(Areca Nut/Dohra)	60 (53.5%)	54 (90%)	6 (10%)	10-15	10-17 yrs
		Gutka	23 (20.4%)	21(91.3%)	2(8.7%)	8-10	7-10 yrs
		Betel quid with areca nut and tobacco	20 (18%)	17 (85%)	3 (15%)	7-9	7-9 yrs
		Smoking (Bidi/Cigarettes/Pipes)	3(2.7%)	3 (100%)	0 (0%)	8-10	9-10 yrs
		Alcohol	1(0.9%)	1 (100%)	0 (0%)	4-5	7-10
		Chewing + Smoking	2(1.8%)	2 (100%)	0 (0%)	6-9	8-10 yrs
		Alcohol+ Chewing	1(0.9%)	1 (100%)	0 (0%)	4-8	7- 9 yrs
		Alcohol+ Smoking	2(1.8%)	2 (100%)	0 (0%)	6-9	8-10 yrs

1031

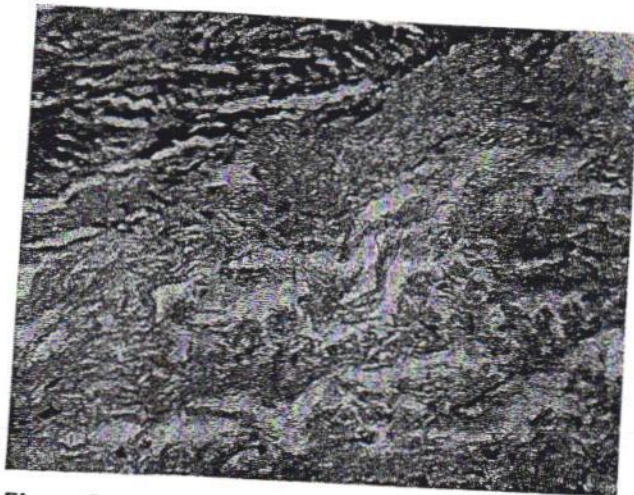

**Figure 5**  
Oral Mucosa showing OSF grade III showing thinning of the epidermis, hyalinized collagen and lymphocytic infiltration. (H and E × 400).

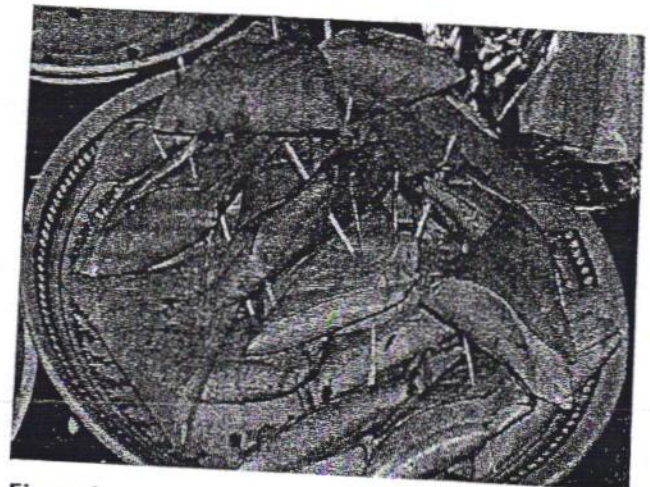

**Figure 6**  
Paan quids being served at a wedding reception.

patients over a 12-month follow-up period in one study [26].

Physical therapy using muscle-stretching exercises for the mouth may be helpful in preventing further limitation of mouth movements. This is often combined with medical and surgical therapy.

Surveillance for OSF is being carried out routinely in the department of Otorhinolaryngology out-patients department at the S.R.N. Hospital associated with the Medical School. As a small percentage of patients with OSF go on

to develop malignancy, correlation of histopathological findings and clinical findings is important.

**Conclusion**

This study concluded that the widespread habits of chewing dohra and paan masala are the major risk factors of OSF, especially affecting the younger generation. An increase is found in histopathological grading and addiction habit and to the best of our knowledge, this correlation has not been attempted before. However no significant correlation was found between trismus and histopathological grading.

**Table 4: Distribution of patients according to staging of trismus and histopathological grading**

Stage of Trismus	Grading			Total
	Grade I	Grade II	Grade III	
Stage I	3 (16.6%)	5 (17.2%)	8 (19%)	16 (17.9%)
Stage II	11 (61.1%)	17 (58.6%)	23 (54.7%)	51 (57.3%)
Stage III	4 (22.2%)	7 (24.1%)	11 (26.1%)	22 (24.7%)
Total	18 (20.2%)	29 (32.5%)	42 (47.1%)	89

1032  
A

## Competing interests

The authors declare that they have no competing interests.

## Authors' contributions

SP and AKC carried out the experimental work, analysis and drafted the manuscript. RM conceived of the study, participated in its design and coordination as well as helped to draft the manuscript. MS and Mamta Singh participated in coordination of the study and helped to draft the manuscript. All authors read and approved the final manuscript.

## References

- Tilakratne WM, Klinikowski MF, Saku T, Peters TJ, Warnakulasuriya S: **Oral submucous fibrosis: Review on aetiology and pathogenesis.** *Oral Oncol* 2005, **30**:30-32.
- Sinor PN, Gupta PC, Murti PR, Bhonsle RB, Daftary DK, Mehta FS: **A case-control study of oral submucous fibrosis with special reference to the aetiological role of areca nut.** *J Oral Pathol Med* 1990, **19**:94-98.
- Lai DR, Chen HR, Lin LM, Huang YL, Tsai CC: **Clinical evaluation of different treatment methods for oral submucous fibrosis. A 10-year experience with 150 cases.** *J Oral Pathol Med* 1995, **24**:402-6.
- Rajalalitha P, Vali S: **Molecular pathogenesis of oral submucous fibrosis-a collagen metabolic disorder.** *J Oral Pathol Med* 2005, **34**:321-28.
- Mehrotra R, Pandya S, Chaudhary AK, Kumar M, Singh M: **Prevalence of oral premalignant and malignant lesions at a tertiary level hospital in Allahabad, India.** *Asian Pac J Cancer Prev* 2008, **9**(2):263-265.
- Pindborg JJ, Odont, Sirsat SM: **Oral submucous fibrosis.** *Oral Surg, Oral Med, Oral Pathol* 1966, **22**:764-79.
- Reichart PA, Philipsen HP: **Oral submucous fibrosis in a 31-year-old Indian woman: first case report from Germany.** *Mund Kiefer Gesichtschir* 2006, **10**(3):192-196.
- Kumar KK, Saraswathi TR, Ranganathan K, Devi MU, Elizabeth J: **Oral submucous fibrosis: A clinico-histopathological study in Chennai.** *Indian J Dent Res* 2007, **18**:106-11.
- Hazarey YK, Erlewad DM, Mundhe KA, Ughade SN: **Oral submucous fibrosis: study of 1000 cases from Central India.** *J Oral Pathol Med* 2006, **35**:1-6.
- Zhang X, Reichart PA: **A review of betel quid chewing, oral cancer and precancer in Mainland China.** *Oral Oncology* 2007, **43**(5):424-30.
- Mehrotra R, Singh M, Kumar D, Pandey AN, Gupta RK, Sinha US: **Age specific incidence rate and pathological spectrum of oral cancer in Allahabad.** *Indian J Med Sci* 2003, **57**:400-04.
- Babu S, Bhat RV, Kumar PU, et al: **A comparative clinico-pathological study of oral submucous fibrosis in habitual chewers of pan masala and betelquid.** *J Toxicol Clin Toxicol* 1996, **34**(3):317-22.
- Thomas G, Hashibe M, Jacob BJ, Ramadas K, Mathew B, Sankaranarayanan R, et al: **Risk factors of multiple oral premalignant lesions.** *Int J Cancer* 2003, **107**:285-91.
- Ho PS, Yang YH, Shieh TY, Huang IY, Chen YK, Lin KN: **Consumption of areca quid, cigarettes, and alcohol related to the comorbidity of oral submucous fibrosis and oral cancer.** *Oral Surg Oral Med Oral Pathol Oral Radiol Endod* 2007, **104**(5):647-652.
- Auluck A, Rosin MP, Zhang L: **Oral submucous fibrosis, a clinically benign but potentially malignant disease: report of 3 cases and review of the literature.** *J Can Dent Assoc* 2008, **74**:735-40.
- Bhurgri Y: **Cancer of the oral cavity – trends in Karachi South.** *Asian Pac J Cancer Prev* 2005, **6**:22-26.
- Reichart PA, Way TH: **Oral cancer and pre-cancer in Myanmar: a short review.** *J Oral Pathol Med* 2006, **35**:193-6.
- Chiu CJ, Lee WC, Chiang CP, Hahen U, Kuo YS, Chen CJ: **A scoring system for the early detection of oral sub mucous fibrosis based on a self administered questionnaires.** *J Pub Health Dentist* 2002, **62**:28-31.
- Maher R, Lee AJ, Warnakulasuriya KA, Lewis JA, Johnson NW: **Role of areca nut in the causation of Oral submucous fibrosis: A case control study in Pakistan.** *J Oral Pathol Med* 1994, **23**:65-69.
- Gupta PC, Sinor PN, Bhonsle RB, Pawar VS, Mehta BC: **Oral submucous fibrosis in India: A new epidemic?** *Natl Med J India* 1998, **11**(3):113-116.
- Shah N, Sharma PP: **Role of chewing and smoking habits in the aetiology of oral submucous fibrosis (OSF): a case control study.** *J Oral Pathol Med* 1998, **27**:475-79.
- Sur TK, Biswas TK, Ali L, Mukherjee B: **Anti-inflammatory and anti-platelet aggregation activity of human placental extract.** *Acta Pharmacol Sin* 2003, **24**(2):187-92.
- Rajendran R, Rani V, Shaikh S: **Pentoxifylline therapy: a new adjunct in the treatment of oral submucous fibrosis.** *Indian J Dent Res* 2006, **17**(4):190-8.
- Haque MF, Meghji S, Nazir R, Harris M: **Interferon gamma (IFN-gamma) may reverse oral submucous fibrosis.** *J Oral Pathol Med* 2001, **30**(1):12-21.
- Kumar A, Bagewadi A, Keluskar V, Singh M: **Efficacy of lycopene in the management of oral submucous fibrosis.** *Oral Surg Oral Med Oral Pathol Oral Radiol Endod* 2007, **103**(2):207-13.
- Nayak DR, Mahesh SG, Aggarwal D, Pavithran P, Pujary K, Pillai S: **Role of KTP-532 laser in management of oral submucous fibrosis.** *J Laryngol Otol* 2008, **123**(4):1-4.

Publish with **BioMed Central** and every scientist can read your work free of charge

"BioMed Central will be the most significant development for disseminating the results of biomedical research in our lifetime."

Sir Paul Nurse, Cancer Research UK

Your research papers will be:

- available free of charge to the entire biomedical community
- peer reviewed and published immediately upon acceptance
- cited in PubMed and archived on PubMed Central
- yours — you keep the copyright

Submit your manuscript here:  
http://www.biomedcentral.com/info/publishing\_adv.asp



1033  
a

J Toxicol Clin Toxicol. 1996;34(3):317-22.

## A comparative clinico-pathological study of oral submucous fibrosis in habitual chewers of pan masala and betelquid.

Babu S, Bhat RV, Kumar PU, Sesikaran B, Rao KV, Aruna P, Reddy PR.

Food Toxicology Research Centre, National Institute of Nutrition, Hyderabad, India.

### Abstract

**BACKGROUND:** Oral submucous fibrosis associated with chewing of betel nut products has an estimated prevalence of 0.2-1.2% in India. The increasing use of pan masala/gutkha, a mix of tobacco and a less moist form of betelquid lacking the betel leaf, seems associated with an earlier age of onset of oral submucous fibrosis.

**METHOD:** A prospective study examined the in vivo effects of pan masala/gutkha and betelquid chewing on buccal mucosal cytology in 50 patients with oral submucous fibrosis and 40 controls.

**RESULTS:** The percentage of nucleolated intermediate cells or proliferative fraction of buccal mucosa cells was significantly higher in all habitual chewers than controls. Pan masala/gutkha chewers presented with oral submucous fibrosis after 2.7 +/- 0.6 y of use whereas the betelquid users presented with oral submucous fibrosis reported 8.6 +/- 2.3 y of use ( $p < 0.05$ ).

**CONCLUSIONS:** Habitual chewing of pan masala/gutkha is associated with earlier presentation of oral submucous fibrosis than betelquid use. Factors which may be responsible for these differences are the tobacco content, the absence of the betel leaf and its carotenes and the much higher dry weight of pan masala/gutkha.

# The precancer risk of betel quid chewing, tobacco use and alcohol consumption in oral leukoplakia and oral submucous fibrosis in southern Taiwan

C-H Lee<sup>1</sup>, Y-C Ko<sup>\*2</sup>, H-L Huang<sup>3</sup>, Y-Y Chao<sup>1</sup>, C-C Tsai<sup>4</sup>, T-Y Shieh<sup>5</sup> and L-M Lin<sup>4</sup>

<sup>1</sup>Graduate Institute of Public Health, College of Health Science, Kaohsiung Medical University, Taiwan, ROC; <sup>2</sup>Graduate Institute of Medicine, College of Medicine, Kaohsiung Medical University, Taiwan, ROC; <sup>3</sup>Department of Nursing, Shu-Zen College of Medicine and Management, Taiwan, ROC; <sup>4</sup>Graduate Institute of Dentistry, College of Dentistry, Kaohsiung Medical University, Taiwan, ROC; <sup>5</sup>Graduate Institute of Oral Health Sciences, College of Dentistry, Kaohsiung Medical University, Taiwan, ROC

Epidemiology

In areas where the practise of betel quid chewing is widespread and the chewers also often smoke and drink alcohol, the relation between oral precancerous lesion and condition to the three habits is probably complex. To explore such association and their attributable effect on oral leukoplakia (OL) and oral submucous fibrosis (OSF), a gender–age-matched case–control study was conducted at Kaohsiung, southern Taiwan. This study included 219 patients with newly diagnosed and histologically confirmed OL or OSF, and 876 randomly selected community controls. All information was collected by a structured questionnaire through in-person interviews. A preponderance of younger patients had OSF, while a predominance of older patients had OL. Betel quid chewing was strongly associated with both these oral diseases, the attributable fraction of OL being 73.2% and of OSF 85.4%. While the heterogeneity in risk for areca nut chewing across the two diseases was not apparent, betel quid chewing patients with OSF experienced a higher risk at each exposure level of chewing duration, quantity and cumulative measure than those who had OL. Alcohol intake did not appear to be a risk factor. However, cigarette smoking had a significant contribution to the risk of OL, and modified the effect of chewing based on an additive interaction model. For the two oral premalignant diseases combined, 86.5% was attributable to chewing and smoking. Our results suggested that, although betel quid chewing was a major cause for both OL and OSF, its effect might be difference between the two diseases. Cigarette smoking has a modifying effect in the development of oral leukoplakia.

British Journal of Cancer (2003) 88, 366–372. doi:10.1038/sj.bjc.6600727 www.bjcancer.com  
© 2003 Cancer Research UK

**Keywords:** oral leukoplakia; oral submucous fibrosis; risk factors; areca; smoking; alcohol drinking

Studies from Pakistan, India and Mainland China consistently showed that chewing of areca nut was the major aetiologic factor for oral leukoplakia (OL) and oral submucous fibrosis (OSF) (Mehta *et al*, 1981; Maher *et al*, 1994; Tang *et al*, 1997). However, in a review of case series, the proportion of areca nut chewers among individuals with OL and OSF varied from 43–68% and 34–100%, respectively (Bhonsle *et al*, 1987; Ikeda *et al*, 1995; Hashibe *et al*, 2000). Factors other than areca nut chewing might play a role in the development of oral precancerous diseases in populations.

Tobacco smoking and alcohol abuse are involved in the pathogenesis of oral cavity cancer, and the two agents appear to act synergistically (Blot *et al*, 1988; Merletti *et al*, 1989; Ko *et al*, 1995). Although OL and OSF are both high-risk preneoplastic states, the independent and interactive associations between cigarette smoking, alcohol consumption and areca nut chewing have not been well established in these oral diseases.

In Taiwan, about 2 million people practise the habit of chewing betel quid. As a high proportion of betel quid chewers are also smokers (86%) or drinkers (74%) in southern Taiwan (Ko *et al*, 1992), we present a case–control study investigating the independent and synergistic effects of betel quid chewing, tobacco use and alcohol consumption in the development of OL and OSF, examining the heterogeneity of risk across both the diseases.

## MATERIALS AND METHODS

### Subject selection and data collection

The study population is composed of residents of the greater Kaohsiung area of Taiwan, which includes a city and some suburban and rural communities. The oral precancerous cases in the study were recruited from Kaohsiung Medical University Hospital, which is a highly regarded teaching hospital in tropical southern Taiwan, and is accessible to patients from all socioeconomic groups. Subjects who visited the hospital's dentistry department during 1994 and 1995 and were suspected of having OL or OSF on clinical criteria were considered as potential cases. Only patients who were newly diagnosed and were histologically confirmed with the two types of oral diseases by pathologists were included. However, patients who

\*Correspondence: Dr Y-C Ko, College of Medicine, Kaohsiung Medical University, No. 100 Shih-Chuan 1st Road, Kaohsiung City, Taiwan, ROC 807. E-mail: ycko@kmu.edu.tw  
Received 2 August 2002; revised 21 October 2002; accepted 25 October 2002.

10356

showed symptoms of both OL and OSF were excluded. Among the 219 oral precancerous patients, 125 cases (57.1%) suffered from OL and 94 cases (42.9%) suffered from OSF.

The controls were selected randomly through a three-step sampling scheme from a population aged 15 years and over in the greater Kaohsiung area. First, we stratified 38 study areas into two strata by levels of urbanization. Then, 19 study areas were chosen randomly from the two strata before selecting 1864 households from these areas. The number of study areas and households sampled from each stratum were probably proportional to their population size. Finally, one individual was randomly selected from each household. Information regarding the age and gender of the selected subjects was verified through telephone interviews. Once a case was identified, four controls matched by age (within 3 years) and gender were selected according to their sequence on the list. If a selected subject refused to participate in the study, the next eligible person on the list would be selected until four controls were recruited. Of these, 184 subjects refused to, or could not, participate in the study. The reasons were: too busy for the interview; out of town; and moving out and could not be located. A total of 876 matched controls participated in the study.

The research workers were trained in the management of oral precancerous cases and controls. Each subject was interviewed face to face about demographic information, occupations, betel quid chewing, smoking history and alcohol drinking habits with a structured questionnaire. Subjects who had chewed one betel quid or more or had smoked one cigarette or more per day for at least 1 year were defined as ever chewers or ever smokers. Subjects who had drunk a bottle of alcoholic beverages (including beer, liquor and wine) or more per month for at least 1 year were defined as ever drinkers. Among them, current users were those who had practised these habits within the past 1 year, and ex-users were those who had stopped the habits for at least 1 year before diagnoses or interviews. For all of the ever chewers and ever smokers, a detailed history of their chewing and smoking habits was recorded, including daily consumption, age of commencement and duration of practice. For ever drinkers, information of the frequency of alcohol intake was collected. To assess the cumulative risks of betel quid chewing and cigarette smoking, the number of 'pack-years', calculated by multiplying the amount (in packs; 20 cigarettes and 10 betel quids per pack) consumed daily by the years of using, was employed as the indicators of chewing and smoking. In addition, the types of regularly chewed betel materials were recorded as follows: areca nut with a piece of inflorescence of *Piper Betel* Linn, areca nut with a piece of betel leaf, and both mixed.

### Statistical analyses

Odds ratios (ORs) and 95% confidence intervals (CI) were estimated for precancer risk of various factors by using conditional logistic regression analyses. Statistical significance of trend was calculated by categorizing exposure variables and treating scored variables as continuous. Separate analyses were conducted for OL and OSF. To control the potential confounding effects, ORs were adjusted for educational level (<7, 7-9, >9 years) and occupation (white collar, farmers, blue collar). The homogeneity of ORs across the two oral precancerous states was examined by the Mantel-Haenszel  $\chi^2$  test, and the strength of heterogeneity in ORs between OSF and OL was expressed as OR ratios (Lee *et al*, 2001). Interactive effects of any suspected risk factors were evaluated by assuming an additive interaction relation. The synergism index (SI) proposed by Rothman and its 95% CI were computed to assess the empirical deviation from the additive interaction relation (Hosmer and Lemeshow, 1992). Also, the proportion of oral premalignant cases attributable to one or all risk factors considered (population attributable risk percent; PAR%) was calculated according to Bruzzi *et al*'s (1985) method.

### RESULTS

The demographic distributions of OL and OSF patients, and their controls are presented by five characteristics in Table 1. Cases and controls in each disease group were closely matched in age and gender. However, the average diagnostic age of subjects suffering from OL ( $47.9 \pm 11.8$  years) was significantly higher than that of subjects suffering from OSF ( $39.1 \pm 11.7$  years). Education and occupation were both associated with these two oral diseases. Patients who were white-collar workers or had higher education levels (>9 years) had a lower risk of oral preneoplastic states (OR = 0.4-0.6).

Table 2 shows the risks of contracting OL and OSF for cigarette smoking and alcohol drinking. Ex-smokers and current smokers were found to experience, respectively, a 5.6-6.5-fold and 6.1-7.0-fold elevated risk of OL and OSF. However, for subjects with a drinking habit, only current drinkers experienced a higher risk of developing the two oral diseases (OR = 1.8 for both diseases). As smoking levels and drinking frequency increased, the risk for developing OL and OSF also increased. A dose-response relation between exposure levels and oral precancer risks was also evidenced ( $P < 0.05$ ).

The characteristics of betel quid chewing history were examined in the case-control pairs for OL and OSF (Table 3). The risks for the two oral premalignant diseases among current chewers were 22.3-40.7-fold higher than that among never chewers, and only 7.1-12.1-fold increases were observed among ex-chewers. The heterogeneity in risk (expressed as an OR ratio) between the two oral diseases was nonsignificant ( $P > 0.05$ ). At each exposure level of chewing duration, quantity and cumulative measure, the betel quid chewing patients with OSF had a higher precancer risk than those with OL. Furthermore, the risk did not relate to the types of betel materials. Chewing betel quid with a piece of *Piper Betel* Linn inflorescence showed the highest precancer risk in both the oral diseases.

The synergistic effects of betel quid chewing, cigarette smoking and alcohol drinking on OL and OSF were evaluated by stratifying the uses of tobacco and alcohol across the habit of betel quid chewing (Table 4). For nonsmokers and nondrinkers who practised the habit of betel quid chewing, the risks of oral OSF increased 39.3- and 26.5-fold, respectively, compared with those who did not have the habit. The risks were largely increased for areca nut chewers who also have the habit of smoking or drinking (OR = 57.9 and 31.7). Similar risk patterns were observed among the patients of OL. However, for smokers who did not chew betel quid, the significant risk of OL was detected. Moreover, cigarette smoking was found to modify the effect of betel quid chewing based on the model of additive interaction (SI = 3.8;  $P < 0.05$ ). Although most of the OR ratios between OSF and OL for areca nut chewing alone or combined with smoking or drinking were larger than one, no statistical heterogeneity was identified.

Multivariate logistic regression analyses were separately conducted for OL, OSF and the two diseases combined (Table 5, Figure 1). Betel quid chewing was found to be the strongest risk factor for both OL (OR > 10) and OSF (OR > 22). While the effect of alcohol drinking on the two oral premalignant diseases was not substantial, the significantly elevated risk of cigarette smoking was detected among OL patients. Among these risk factors, betel quid chewing accounted for 73.2 and 85.4% of attributable risks of contracting OL and OSF, respectively. Combined with cigarette smoking, the population attributable risk proportion of OL increased to 84.4%. In the same way, 86.5% of the aetiologic fraction for patients having either OL or OSF was detected (Figure 1).

### DISCUSSION

This study found that betel quid chewing was the principal cause of OL and OSF. Subjects who ever chewed areca nut experienced a

1936  
2

**Table 1** Distributions and odds ratios of OL and OSF associated with demographic factors, Taiwan

Factor/category	Oral leukoplakia			Oral submucous fibrosis		
	No. of cases	No. of controls	OR (95% CI)	No. of cases	No. of controls	OR (95% CI)
Age (years)						
<31	5	20		22	88	
31-40	37	148		38	152	
41-50	31	124		16	64	
>50	52	208		18	72	
Gender						
Male	118	472		93	372	
Female	7	28		1	4	
Ethnicity						
Fukienese	97	378	1.0	71	287	1.0
Mainlander	14	54	1.0 (0.5-2.1)	10	35	1.1 (0.5-2.5)
Hakka	11	65	0.7 (0.3-1.3)	11	50	0.9 (0.4-1.8)
Aborigines	3	3	3.9 (0.8-19.6)	2	4	2.2 (0.3-13.4)
Years of education						
<7	74	259	1.0	37	110	1.0
7-9	21	84	0.8 (0.4-1.4)	19	78	0.6 (0.3-1.2)
>9	30	157	0.6 (0.3-0.9)	38	188	0.4 (0.2-0.8)
Occupation						
Blue collar	77	269	1.0	56	183	1.0
Farmer	25	90	1.0 (0.6-1.7)	15	49	1.1 (0.5-2.2)
White collar	23	141	0.6 (0.3-0.9)	23	144	0.5 (0.3-0.9)

**Table 2** Odds ratios of OL and OSF associated with cigarette smoking and alcohol drinking, Taiwan

Factor/category	Oral leukoplakia			Oral submucous fibrosis		
	No. of cases	No. of controls	OR* (95% CI)	No. of cases	No. of controls	OR* (95% CI)
Cigarette smoking						
Never <sup>b</sup>	19	258	1.0	10	188	1.0
Ex	6	16	5.6 (1.9-16.6)	5	14	6.5 (1.9-22.3)
Current	100	226	6.1 (3.4-10.6)	79	174	7.0 (3.5-14.3)
Dose-response			2.4 (1.8-3.1)			2.5 (1.8-3.5)
Cumulative pack-years						
1-10	32	84	5.3 (2.7-10.4)	36	95	5.7 (2.6-12.3)
11-20	26	66	5.4 (2.7-10.9)	20	41	8.6 (3.6-20.7)
>20	48	92	7.0 (3.7-13.2)	28	52	8.6 (3.7-20.2)
Dose-response			1.8 (1.5-2.1)			2.0 (1.5-2.5)
Alcohol drinking						
Never <sup>b</sup>	72	349	1.0	55	266	1.0
Ex	9	40	1.1 (0.5-2.4)	7	27	1.4 (0.6-3.4)
Current	44	111	1.8 (1.1-2.8)	32	83	1.8 (1.1-3.1)
Dose-response			1.3 (1.1-1.7)			1.4 (1.0-1.8)
Drinking frequency						
Monthly	9	40	1.1 (0.5-2.4)	7	27	1.4 (0.6-3.4)
Weekly	24	60	1.9 (1.1-3.3)	17	42	1.9 (1.0-3.7)
Daily	20	51	1.7 (0.9-3.0)	15	41	1.7 (0.9-3.5)
Dose-response			1.2 (1.0-1.5)			1.2 (1.0-1.5)

\*Odds ratios were adjusted for education and occupation.

<sup>b</sup>Never smokers and never drinkers were reference categories, respectively.

more than 11-fold risk of these precancerous conditions. The risks increased with the duration and frequency of the habit, as previously shown in Pakistan, India, Taiwan and Mainland China (Mehta *et al*, 1981; Maher *et al*, 1994; Tang *et al*, 1997; Shiu *et al*, 2000).

The chewing of betel quid is practised in several different ways in various countries, while the major components are comparatively consistent. In India and Southeast Asia, tobacco was usually used as an ingredient for areca nut products (called 'pan'), but not in Taiwan. A higher relative risk of oral cancer for betel quid

1937  
E

**Table 3** Odds ratios of OL and OSF associated with betel quid chewing, Taiwan

Betel quid chewing/category	Oral leukoplakia		Oral submucous fibrosis		OR <sup>b</sup> ratio
	Cases/controls	OR <sup>a</sup> (95% CI)	Cases/controls	OR <sup>a</sup> (95% CI)	
Never <sup>c</sup>	28/390	1.0	11/302	1.0	
Ex	6/22	7.1 (2.3-21.5)	5/12	12.1 (2.8-51.9)	
Current	91/88	22.3 (11.3-43.8)	78/62	40.7 (16.0-103.7)	
Dose-response		4.6 (3.3-6.4)		6.2 (3.9-9.7)	1.3
Age first chewed (years)					
≥26	51/56	20.6 (9.9-42.7)	37/34	32.3 (12.1-86.6)	
<26	46/54	19.5 (9.3-41.0)	46/40	39.4 (14.8-105.3)	
Dose-response		4.3 (3.1-6.0)		5.8 (3.8-8.8)	1.3
Duration of chewing (years)					
1-10	33/48	15.9 (7.1-35.6)	36/36	30.9 (11.3-84.7)	
11-20	27/33	20.7 (8.9-48.2)	28/25	41.9 (14.1-124.9)	
≥21	37/29	24.0 (10.8-53.4)	19/13	39.3 (11.7-131.7)	
Dose-response		3.0 (2.3-3.9)		4.2 (3.0-6.1)	1.4
Quantity of chewing (pieces/day)					
1-10	53/73	16.6 (8.2-33.8)	41/42	31.4 (11.9-82.5)	
11-20	24/25	21.0 (8.9-49.7)	24/21	37.4 (12.6-110.4)	
≥21	20/12	38.5 (14.1-105.1)	18/11	53.5 (16.4-174.8)	
Dose-response		3.8 (2.8-5.1)		4.1 (2.9-5.8)	1.1
Cumulative pack-years					
1-10	33/64	12.0 (5.6-25.7)	35/41	26.5 (10.0-70.3)	
11-20	17/15	23.7 (9.1-61.7)	21/16	47.0 (15.8-139.8)	
≥21	47/31	31.4 (14.2-69.2)	27/17	51.4 (16.5-159.7)	
Dose-response		3.1 (2.4-3.9)		4.1 (2.9-5.8)	1.3
Types of material					
With betel inflorescence	60/56	24.5 (11.8-50.7)	47/38	38.7 (14.7-101.9)	
With betel leaf	11/24	11.5 (4.2-32.0)	8/15	18.7 (5.3-66.1)	1.6
Mixed	26/30	17.4 (7.6-39.8)	28/21	37.4 (13.1-107.2)	1.6
					2.1

<sup>a</sup>Odds ratios were adjusted for education and occupation.

<sup>b</sup>The heterogeneity in ORs between OSF and OL was expressed as OR ratio.

<sup>c</sup>Never chewers were a reference category.

**Table 4** Synergistic effects of OL and OSF between betel quid chewing, cigarette smoking and alcohol drinking, Taiwan

Factors/category	Oral leukoplakia			Oral submucous fibrosis			OR <sup>b</sup> ratio
	Cases/controls	OR (95% CI)	SI <sup>a</sup> (95% CI)	Cases/controls	OR (95% CI)	SI <sup>a</sup> (95% CI)	
Betel chewing/cigarette smoking <sup>d-d</sup>							
No/no	12/235	1.0		4/178	1.0		
No/yes	16/155	2.4 (1.0-5.5)		7/124	2.3 (0.6-9.1)		1.0
Yes/no	7/23	10.0 (3.1-32.7)		6/10	39.3 (7.5-206.9)		3.9
Yes/yes	90/87	40.2 (16.3-99.2)	3.8 (1.4-10.5)	77/64	57.9 (16.0-209.6)	1.4 (0.4-4.7)	1.4
Betel chewing/alcohol drinking <sup>e-e</sup>							
No/no	22/292	1.0		9/223	1.0		
No/yes	6/98	1.0 (0.4-2.6)		2/79	0.7 (0.1-3.4)		0.7
Yes/no	50/57	15.6 (7.1-34.3)		46/43	26.5 (9.5-74.1)		1.7
Yes/yes	47/53	16.8 (7.2-39.5)	1.1 (0.6-2.1)	37/31	31.7 (10.1-99.3)	1.2 (0.6-2.5)	1.9

<sup>a</sup>Synergism index estimated by an additive interaction model.

<sup>b</sup>The heterogeneity in ORs between OSF and OL was expressed as OR ratio.

<sup>c</sup>'Yes' referred to the 'ever users' for betel quid chewing, cigarette smoking and alcohol drinking.

<sup>d</sup>Odds ratios were adjusted for education, occupation and alcohol drinking.

<sup>e</sup>Odds ratios were adjusted for education, occupation and cigarette smoking.

chewing with tobacco was notably higher than that for betel quid chewing without tobacco, and the evidence for OL was also in the same direction (Gupta *et al*, 1982). Our study showed that non-smokers and nondrinkers who chewed betel quid had, respectively, a 10.0-15.6- and 26.5-39.3-fold significant risk of OL and OSF

(Table 4), and both risks were lower than that reported for tobacco-contained areca nut products (OR = 17.4 and 44.1 for OL and OSF, respectively) (IARC, 1985; Hashibe *et al*, 2000). The difference in risks between areca nut with and without tobacco implies that tobacco could have an additional effect on OL and OSF.

1038  
R

**Table 5** Adjusted odds ratios and population attributable risk proportions (PAR%) of OL and OSF associated with independent factors, Taiwan

Factor/category	Oral leukoplakia		Oral submucous fibrosis	
	OR* (95% CI)	PAR%	OR* (95% CI)	PAR%
<i>Cumulative betel quid chewing in pack-years</i>				
No	1.0	73.2	1.0	85.4
1-10	10.2 (4.6-23.1)		22.4 (8.0-62.3)	
11-20	24.5 (8.8-68.1)		40.4 (12.9-126.6)	
≥21	28.8 (11.9-69.5)		44.0 (12.8-151.8)	
<i>Cumulative cigarette smoking in pack-years</i>				
No	1.0	56.4	1.0	
1-10	3.3 (1.5-7.2)		1.8 (0.7-5.1)	
11-20	3.0 (1.3-7.2)		2.0 (0.6-6.4)	
≥21	2.8 (1.3-6.0)		1.6 (0.5-5.0)	
<i>Alcohol drinking</i>				
No	1.0		1.0	
Monthly	1.0 (0.4-2.7)		0.8 (0.3-2.5)	
Weekly	1.1 (0.5-2.2)		1.3 (0.5-3.1)	
Daily	0.8 (0.4-1.7)		0.9 (0.3-2.5)	
<i>Years of education</i>				
<7	1.0		1.0	
7-9	1.6 (0.8-3.2)		0.7 (0.3-1.8)	
>9	1.0 (0.5-2.1)		0.6 (0.2-1.7)	
<i>Occupation</i>				
Blue collar	1.0		1.0	
Farmer	0.6 (0.3-1.2)		0.5 (0.2-1.4)	
White collar	1.1 (0.6-2.2)		1.0 (0.4-2.1)	
Summary population attributable risk proportion (%)		84.4		85.4

\* Odds ratios were derived from the multivariate logistic regression model adjusted for the table's covariates.

Significantly elevated risks of OL and OSF were registered at the lowest levels of betel chewing quantity (1-10 pieces day<sup>-1</sup>) and duration (1-10 years). The data indicated that even a relatively short exposure is sufficient to induce leukoplakia or mucous fibrosis, as previously suggested (Seedat and Van Wyk, 1988; Maher *et al*, 1994). Arecoline, the most abundant alkaloid in areca nut, has been observed experimentally to stimulate collagen synthesis by fibroblasts *in vitro* (Canniff and Harvey, 1981). Studies of human buccal fibroblasts found that arecoline was not only cytotoxic but stimulated double-stranded polynucleic acid synthesis; both might act synergistically on the pathogenesis of OSF as well as oral cancer (Chang *et al*, 1998).

OL and OSF are clinically distinct precancerous lesions that precede the development of oral cancer. Our study showed that the risk of OSF at each exposure level of betel quid chewing was stronger than those of OL, although the difference was not large enough to reject the null. Similar results were found in large-scale case-control studies conducted in India (Hashibe *et al*, 2000, 2002). We also found that mainly younger patients had OSF compared with mainly older patients with OL. The fact that OSF patients started betel quid chewing at a younger age than OL patients and chewed more quids per day may partly explain the age differences between the two diseases.

Our multivariate analyses indicated that cigarette smoking was an independent risk factor for OL, but not for OSF. While the associations between tobacco smoking and the two types of oral premalignant diseases have not been definitely established, comparable findings were observed in India and Europe (Banoczy *et al*, 2001; Hashibe *et al*, 2000, 2002). We found a significant precancer risk of cigarette smoking among OL patients who did not chew betel. In contrast, the effects of betel quid chewing alone

on OSF among nonsmokers and nondrinkers were much higher than those on OL (OR ratios ≥1.7), reflecting the substantial role of smoking in OL, although the effect of betel quid chewing is much stronger on OSF, as discussed earlier. In addition, it has been noticed that the risk of OL and OSF is greatly increased in the presence of both betel quid chewing and smoking (Table 4). Cigarette smoking was found to modify the effect of betel quid chewing in OL based on an additive interaction model. However, the joint risk of OSF for the two factors was still higher than the combined risk of OL, assessed by multiple logistic regression models.

Although ethanol has been recognized as a solvent that may damage the oral cells and increase the mucosal penetration of certain oral carcinogens (Hashibe *et al*, 2000), the role of alcohol drinking in the development of OL is still unclear. In a cross-sectional study, an independent effect of alcohol use on OL was not identified (Gupta, 1984) nor in Uzbekistan (Evsitfeeva and Zaridze, 1992). In contrast, studies in Kenya (Macigo *et al*, 1996) and India (Hashibe *et al*, 2000) suggested that drinking was a moderate risk factor, and a clear dose-response relation between alcohol consumption and OL was evidenced. In our study, alcohol intake was not associated with OL. Among OL patients with precancerous lesion, 88.7 and 98.1% of alcohol users were also betel quid and tobacco consumers, respectively. The nonsignificant risks in the multiple regression models indicated that the effect of drinking was explained by betel quid chewing and cigarette smoking. Alcohol use was not an important risk factor for OL in our southern Taiwan population. On the other hand, our study indicated that alcohol consumption was not related to OSF. This result was consistent with the findings from previous studies (Maher *et al*, 1994; Yang *et al*, 2001).

1039  
2

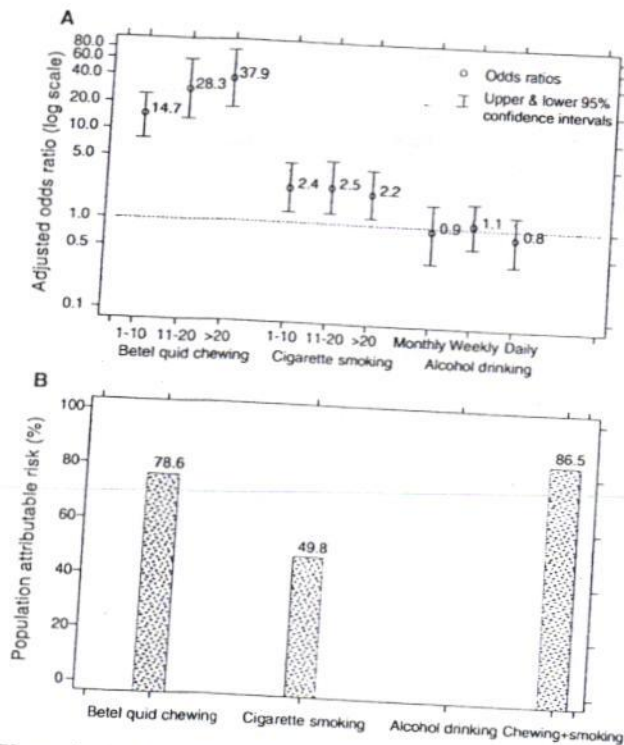

**Figure 1** (A) Adjusted ORs and CIs, and (B) population attributable risk proportions of OL and OSF combined associated with betel quid chewing, cigarette smoking and alcohol drinking, Taiwan.

Oral cancer has been one of the 10 leading causes of cancer deaths in Taiwan since 1982. The mortality of oral cancer increased about 2.6-fold from 1971 to 1997 (Department of Health (ROC), 1998), making its prevention an important public health issue in Taiwan. Since it is often preceded by OL and OSF, and the cessation of areca nut chewing has been associated with a regression in the incidence of OL (Gupta *et al*, 1995), study of their risk factors and their population attributable risk proportion may allow better directed prevention efforts. Our study showed that 73.2 and 56.4% of the aetiologic fraction of OL were, respectively, attributable to betel quid chewing and cigarette smoking. In contrast, the habit of chewing betel quid accounted for 85.4% of attributable risk of OSF. Additionally, it is reasonable to expect that the avoidance of chewing and smoking may possibly prevent 86.5% of the two oral premalignant diseases, and thereby be of considerable health benefit to Taiwan.

One concern in this study is that the oral cavity status of controls was not examined. Since the incidence of the two oral diseases was relatively low, the bias resulting from the inclusion of possible cases in the control group should be limited, and should, if anything, tend to underestimate the risks.

In summary, the chewing of betel quid significantly contributed to the risks of having OL and OSF, and an overwhelming majority were attributable to the practise of areca nut chewing. Cigarette smoking also had a substantial role in the occurrence of OL and potentiated the effect of betel quid chewing.

#### ACKNOWLEDGEMENT

This study was supported in part by a grant from the National Health Research Institutes (Grant No. NHRI-CN-IN-9006P).

#### REFERENCES

- Banoczy J, Gintner Z, Dombi C (2001) Tobacco use and oral leukoplakia. *J Dent Educ* 65: 322-327.
- Bhonsle RB, Murti PR, Daftary DK, Gupta PC, Mehta FS, Sinor PN, Irani RR, Pindborg JJ (1987) Regional variations in oral submucous fibrosis in India. *Community Dent Oral Epidemiol* 15: 225-229.
- Blot WJ, McLaughlin JK, Winn DM, Austin DF, Greenberg RS, Preston-Martin S, Bernstein L, Schoenberg JB, Stemhagen A, Fraumeni Jr JF (1988) Smoking and drinking in relation to oral and pharyngeal cancer. *Cancer Res* 48: 3282-3287.
- Bruzzi P, Green SB, Byar DP, Brinton LA, Schairer C (1985) Estimating the population attributable risk for multiple risk factors using case-control data. *Am J Epidemiol* 122: 904-914.
- Canniff JP, Harvey W (1981) The aetiology of oral submucous fibrosis: the stimulation of collagen synthesis by extracts of areca nut. *Int J Oral Surg* 10: 163-167.
- Chang YC, Tai KW, Cheng MH, Chou LS, Chou MY (1998) Cytotoxic and non-genotoxic effects of arecoline on human buccal fibroblasts *in vitro*. *J Oral Pathol Med* 27: 68-71.
- Department of Health (ROC), E.Y., Republic of China (1998) *Health statistics, Vol. II Vital statistics: 1972-1998*. Taipei: Department of Health, E.Y., ROC.
- Evstifeeva TV, Zaridze DG (1992) Nass use, cigarette smoking, alcohol consumption and risk of oral and oesophageal precancer. *Eur J Cancer B Oral Oncol* 28B: 29-35.
- Gupta PC (1984) Epidemiologic study of the association between alcohol habits and oral leukoplakia. *Community Dent Oral Epidemiol* 12: 47-50.
- Gupta PC, Murti PR, Bhonsle RB, Mehta FS, Pindborg JJ (1995) Effect of cessation of tobacco use on the incidence of oral mucosal lesions in a 10-yr follow-up study of 12,212 users. *Oral Dis* 1: 54-58.
- Gupta PC, Pindborg JJ, Mehta FS (1982) Comparison of carcinogenicity of betel quid with and without tobacco: an epidemiological review. *Ecol Dis* 1: 213-219.
- Hashibe M, Sankaranarayanan R, Thomas G, Kuruvilla B, Mathew B, Somanathan T, Parkin DM, Zhang ZF (2000) Alcohol drinking, body mass index and the risk of oral leukoplakia in an Indian population. *Int J Cancer* 88: 129-134.
- Hashibe M, Sankaranarayanan R, Thomas G, Kuruvilla B, Mathew B, Somanathan T, Parkin DM, Zhang ZF (2002) Body mass index, tobacco chewing, alcohol drinking and the risk of oral submucous fibrosis in Kerala, India. *Cancer Causes Control* 13: 55-64.
- Hosmer DW, Lemeshow S (1992) Confidence interval estimation of interaction. *Epidemiology* 3: 452-456.
- IARC (1985) Betel-quid and areca-nut chewing. *IARC Monogr Eval Carcinog Risk Chem Hum* 37: 137-202.
- Ikeda N, Handa Y, Khim SP, Durward C, Axell T, Mizuno T, Fukano H, Kawai T (1995) Prevalence study of oral mucosal lesions in a selected Cambodian population. *Community Dent Oral Epidemiol* 23: 49-54.
- Ko YC, Chiang TA, Chang SJ, Hsieh SF (1992) Prevalence of betel quid chewing habit in Taiwan and related sociodemographic factors. *J Oral Pathol Med* 21: 261-264.
- Ko YC, Huang YL, Lee CH, Chen MJ, Lin LM, Tsai CC (1995) Betel quid chewing, cigarette smoking and alcohol consumption related to oral cancer in Taiwan. *J Oral Pathol Med* 24: 450-453.
- Lee CH, Ko YC, Cheng LS, Lin YC, Lin HJ, Huang MS, Huang JJ, Kao EL, Wang HZ (2001) The heterogeneity in risk factors of lung cancer and the difference of histologic distribution between genders in Taiwan. *Cancer Causes Control* 12: 289-300.
- Macigo FG, Mwaniki DL, Guthua SW (1996) Influence of dose and cessation of kuraiku, cigarettes and alcohol use on the risk of developing oral leukoplakia. *Eur J Oral Sci* 104: 498-502.
- Maher R, Lee AJ, Warnakulasuriya KA, Lewis JA, Johnson NW (1994) Role of areca nut in the causation of oral submucous fibrosis: a case-control study in Pakistan. *J Oral Pathol Med* 23: 65-69.

1040  
2

- Mehta FS, Gupta PC, Pindborg JJ (1981) Chewing and smoking habits in relation to precancer and oral cancer. *J Cancer Res Clin Oncol* 99: 35-39.
- Merletti F, Boffetta P, Ciccone G, Mashberg A, Terracini B (1989) Role of tobacco and alcoholic beverages in the etiology of cancer of the oral cavity/oropharynx in Torino, Italy. *Cancer Res* 49: 4919-4924.
- Seedat HA, Van Wyk CW (1988) Betel chewing and dietary habits of chewers without and with oral submucous fibrosis and with concomitant oral cancer. *S Afr Med J* 74: 572-575.
- Shiu MN, Chen TH, Chang SH, Hahn LJ (2000) Risk factors for leukoplakia and malignant transformation to oral carcinoma: a leukoplakia cohort in Taiwan. *Br J Cancer* 82: 1871-1874.
- Tang JG, Jian XF, Gao ML, Ling TY, Zhang KH (1997) Epidemiological survey of oral submucous fibrosis in Xiangtan City, Hunan Province, China. *Community Dent Oral Epidemiol* 25: 177-180.
- Yang YH, Lee HY, Tung S, Shieh TY (2001) Epidemiological survey of oral submucous fibrosis and leukoplakia in aborigines of Taiwan. *J Oral Pathol Med* 30: 213-219.

## PAAN WITHOUT TOBACCO: AN INDEPENDENT RISK FACTOR FOR ORAL CANCER

Anwar MERCHANT<sup>1,2,3\*</sup>, Syed S. M. HUSAIN<sup>4</sup>, Mervyn HOSAIN<sup>5</sup>, Fariyal F. FIKREE<sup>2</sup>, Waranuch PITIPHAT<sup>3,6,7</sup>, Amna Rehana SIDDIQUI<sup>2</sup>, Syed J. HAYDER<sup>4</sup>, Syed M. HAIDER<sup>8</sup>, Mubashir IKRAM<sup>4</sup>, Sung-Kiang CHUANG<sup>7,6</sup> and Shaikh A. SAEED<sup>9</sup>

<sup>1</sup>Department of Nutrition, Harvard School of Public Health, Boston, MA, USA

<sup>2</sup>Department of Community Health Sciences, Aga Khan University, Karachi, Pakistan

<sup>3</sup>Department of Epidemiology, Harvard School of Public Health, Boston, MA, USA

<sup>4</sup>Department of Surgery, Aga Khan University, Karachi, Pakistan

<sup>5</sup>Department of Oral and Maxillofacial Surgery, Civil Hospital Karachi, Pakistan

<sup>6</sup>Department of Oral Health Policy and Epidemiology, Harvard School of Dental Medicine, Boston, MA, USA

<sup>7</sup>Faculty of Dentistry, Khon Kaen University, Khon Kaen, Thailand

<sup>8</sup>Department of Oral and Maxillofacial Surgery, Abbassi Shaheed Hospital, Karachi, Pakistan

<sup>9</sup>Department of Pharmacology, Aga Khan University, Karachi, Pakistan

Oral cancer is the second most common cancer in women and the third most common in men in Pakistan. Tobacco is smoked and chewed extensively in Pakistan. Paan is a quid of piper betel leaf that contains areca nut, lime, condiment, sweeteners, and sometimes tobacco, which is also used extensively. We did this study to clarify the independent association of paan and oral cancer. Between July 1996 and March 1998, we recruited biopsy-proven, primary cases of oral squamous-cell carcinoma, from 3 tertiary teaching centers in Karachi, Pakistan, and controls pair-matched for age, gender, hospital and time of occurrence, excluding persons with a past or present history of any malignancy. There were 79 cases and 149 controls. Approximately 68% of the cases were men, 49 years old on average, the youngest being 22 years old and the eldest 80. People with oral submucous fibrosis were 19.1 times more likely to develop oral cancer than those without it, after adjusting for other risk factors. People using paan without tobacco were 9.9 times, those using paan with tobacco 8.4 times, more likely to develop oral cancer as compared with non-users, after adjustment for other covariates. This study identifies an independent effect of paan without tobacco in the causation of oral cancer. Its findings may be of significance in South Asian communities where paan is used, and among health-care providers who treat persons from South Asia. *Int. J. Cancer* 86:128-131, 2000.  
© 2000 Wiley-Liss, Inc.

Oral cancer is the second most common cancer in women and the third most common in men in Pakistan (Jafarey and Zaidi, 1987). Tobacco, chewed or smoked, is a well-established cause of oral squamous-cell carcinoma (Gupta *et al.*, 1982; Jayant and Deo, 1986; Brennan *et al.*, 1995). Alcohol, particularly in association with tobacco, increases the risk of oral cancer. Approximately 40% of men in Pakistan over the age of 15 years smoke cigarettes or bidis (locally cured tobacco rolled in a dry leaf) regularly (National Health Survey of Pakistan, 1997). Tobacco is chewed in Pakistan as paan and as naswar. Paan consists of piper betel leaf containing lime, areca nut, condiments, sweeteners and sometimes tobacco. It is chewed and held in the mouth like a quid. Naswar is a mixture of tobacco and lime (Jayant and Deo, 1986). Areca nut without tobacco is suspected of being associated with oral cancer, but epidemiological studies have not clearly demonstrated its independent effect (Dave *et al.*, 1992). A study has shown significantly more chromosomal aberrations, sister chromatid exchanges, and genomic damage among areca-nut users than among non-users, independently of tobacco use (Dave *et al.*, 1992). But areca-nut users, independently of tobacco use, are 100 times more likely to get oral submucous fibrosis, which is a pre-cancerous lesion of the mouth (Maher *et al.*, 1994). A study from South Africa showed increased risk of oral cancer from chewing areca nut, but the estimates were not adjusted for all important risk factors (van Wyk *et al.*, 1993). We did this study to clarify the independent association of paan and oral cancer.

### MATERIAL AND METHODS

Between July 1996 and March 1998, we recruited biopsy-proven primary cases of oral squamous-cell carcinoma, from Aga Khan University Hospital (AKUH), Civil Hospital Karachi (CHK) and Abbassi Shaheed Hospital (ASH). All 3 hospitals are tertiary teaching centers located in Karachi, Pakistan. AKUH and CHK have attached undergraduate medical colleges. Patients attend all 3 hospitals from all over the province. Sindh is Pakistan's second largest province, with a population of approximately 30 million. Karachi is the largest city in Sindh, with a multi-ethnic population of 9.8 million according to the 1998 census.

We pair-matched controls from patients who had been admitted to the orthopedic and general surgical wards of the same hospital at the same time as the corresponding case, were of the same sex, and were aged within 5 years of the cases. We excluded as controls persons with a past or present history of any malignancy.

After obtaining verbal consent, a trained interviewer administered a structured, pre-tested, questionnaire in Urdu (the *lingua franca* of Pakistan), examined the mouth, and checked for the presence of oral submucous fibrosis (OSMF) on cases and controls. This was determined clinically by observation of blanching and by palpation for the presence of fibrous bands. The interviewer was clinically trained to check the clinical signs of the disease. In addition to socio-economic and demographic data, we also collected information on the use of cigarettes, bidis, hookah, naswar, paan, areca nut, and alcohol. We defined users of naswar, paan or areca nut as someone who had ever indulged in the habit daily for a month. Smokers were persons who had ever smoked cigarettes, bidis, hookah, cigar, or a pipe daily for at least one month. For each of the substances we asked the date of starting, current use or date of quitting, and average quantity used per day. During anal-

**Definitions:** Oral submucous fibrosis (OSMF), Progressive fibrosis of the oral mucosa resulting in limited mouth opening. Strongly associated with areca nut use; pre-cancerous. Paan without tobacco, Piper betel leaf containing lime, areca nut, condiments and sweeteners. It is chewed and held in the mouth like a quid. Paan with tobacco, Piper betel leaf containing lime, areca nut, condiments, sweeteners and tobacco. It is chewed and held in the mouth like a quid. Naswar, Tobacco and lime mixture that is chewed and held in the mouth like a quid. Bidi, Locally cured tobacco rolled in a dry leaf and smoked. Hookah, Hubble-bubble. A pipe for smoking tobacco in which the smoke is filtered through water before inhalation.

Grant sponsor: Aga Khan University, Karachi.

\*Correspondence to: Department of Nutrition, Harvard School of Public Health, 665 Huntington Avenue, Boston, MA 02115, USA. Fax: +1 617 432-2435. E-mail: amerchan@hsph.harvard.edu

Received 10 September 1999; Revised 16 November 1999

1042

Since few people reported that they drank, we observed an association with alcohol in the univariate analysis (Table III), but not in the multivariate model, when alcohol was evaluated with other factors. Alcohol use may be under-reported because it is a restricted substance in Pakistan.

As in any case-control study, there was a chance of recall bias: the cases may have recalled exposure better than the controls. To allow for this, we used pre-tested, structured questions and trained the interviewers. It is possible that the interviewers, who were aware of the hypothesis, probed the cases more than the controls, creating a bias away from the null.

This study identifies an independent effect of paan without tobacco in the causation of oral cancer. Its findings are of significance for South Asian communities, where paan is used and sold

freely, and for health-care providers who treat persons from South Asia.

#### ACKNOWLEDGEMENTS

We are deeply indebted to the participants of this study who gave us their time, to the Aga Khan University, Karachi, Pakistan who provided funds, and to the management of Civil Hospital Karachi and Abbassi Shaheed Hospital for their participation. We thank Dr. S. P. Luby, who reviewed early drafts of the manuscript and offered valuable suggestions, Dr. R. Kumar and Dr. A. Amirali, who collected part of the data, Ms. N. Hirani and Ms. R. Vellani who helped in data cleaning, and Mr. R. Bux who organized the data entry.

#### REFERENCES

- BRENNAN, J.A., BOYLE, J.O., KOCH, W.M., GOODMAN, S.N., HRUBAN, R.H., EBY, Y.J., COUCH, M.J., FORASTIERE, A.A. and SIDRANSKY, D., Association between cigarette smoking and mutation of the *p53* gene in squamous-cell carcinoma of the head and neck. *New Engl. J. Med.* **332**, 712-717 (1995).
- CHOI, S.Y. and KAHYO, H., Effect of cigarette smoking and alcohol consumption in the aetiology of cancer of the oral cavity, pharynx and larynx. *Int. J. Epidemiol.* **20**, 878-885 (1991).
- DAFTARY, D.K., MURTI, P.R., BHONSLE, R.B., GUPTA, P.C., MEHTA, F.S. and PINDBORG, J.J., Oral pre-cancerous lesions and conditions of tropical interest. In: S.R. Prabhu, D.F. Wilson, D.K. Daftary and N.W. Johnson (eds.), *Oral diseases in the tropics*, pp. 417-422, Oxford University Press, New Delhi (1993a).
- DAFTARY, D.K., MURTI, P.R., BHONSLE, R.B., GUPTA, P.C., MEHTA, F.S. and PINDBORG, J.J., Oral squamous-cell carcinoma. In: S.R. Prabhu, D.F. Wilson, D.K. Daftary and H.W. Johnson (eds.), *Oral diseases in the tropics*, pp. 429-448, Oxford University Press, New Delhi (1993b).
- DAVE, B.J., TRIVEDI, A.H. and ADHVARYU, S.G., Role of areca-nut consumption in the cause of oral cancers. A cytogenetic assessment. *Cancer*, **70**, 1017-1023 (1992).
- DEAN, A.G., DEAN, J.A. and COULOMBIER, D., *Epi Info Version 6, A word-processing, database and statistics program for public health on IBM-compatible microcomputers*, (1994).
- FAHMY, M.S., SADEGHI, A. and BEHMARD, S., Epidemiologic study of oral cancer in Fars Province, Iran. *Community Dent. oral Epidemiol.* **11**, 50-58 (1983).
- GUPTA, P.C., PINDBORG, J.J. and MEHTA, F.S., Comparison of carcinogenicity of betel quid with and without tobacco: an epidemiological review. *Ecol. Dis.* **1**, 213-219 (1982).
- JAFAREY, N.A. and ZAIDI, S.H., Cancer in Pakistan. *J. Pakist. med. Ass.* **37**, 178-183 (1987).
- JAYANT, K. and DEO, M.G., Oral cancer and cultural practices in relation to betel quid and tobacco chewing and smoking. *Cancer Detect. Prev.* **9**, 207-213 (1986).
- LANGDON, J.D. and PARTRIDGE, M., Expression of the tumour-suppressor gene *p53* in oral cancer. *Brit. J. oral maxillofac. Surg.* **30**, 214-220 (1992).
- MAHER, R., LEE, A.J., WARNAKULASURIYA, K.A., LEWIS, J.A. and JOHNSON, N.W., Role of areca nut in the causation of oral submucous fibrosis: a case-control study in Pakistan. *J. oral Pathol. Med.* **23**, 65-69 (1994).
- NATIONAL HEALTH SURVEY OF PAKISTAN, 1990-94: *Health profile of the people of Pakistan*, pp. 70-83 (1997).
- NEGRI, E., LA VECCHIA, C., FRANCESCHI, S. and TAVANI, A., Attributable risk for oral cancer in northern Italy. *Cancer Epidemiol Biomarkers Prev.* **2**, 189-193 (1993).
- PILLAI, R., BALARAM, P. and REDDIAR, K.S., Pathogenesis of oral submucous fibrosis. Relationship to risk factors associated with oral cancer. *Cancer*, **69**, 2011-2020 (1992).
- SAS Release 6.12. SAS Institute Inc., Cary, NC (1996).
- VAN WYK, C.W., STANDER, I., PADAYACHEE, A. and GROBLER-RABIE, A.F., The areca-nut-chewing habit and oral squamous-cell carcinoma in South African Indians. *S. Afr. med. J.* **83**, 425-429 (1993).

1045 R

Annexure 1

## Risk factors for leukoplakia and malignant transformation to oral carcinoma: a leukoplakia cohort in Taiwan

MN Shiu<sup>1</sup>, THH Chen<sup>1</sup>, SH Chang<sup>1</sup> and LJ Hahn<sup>2</sup>

<sup>1</sup>Graduate Institute of Epidemiology, College of Public Health, and <sup>2</sup>School of Dentistry, College of Medicine, National Taiwan University, Taipei, Taiwan

**Summary** The effects of betel nut chewing, smoking and alcohol on the occurrence of leukoplakia and its malignant transformation to oral carcinoma were quantified in a leukoplakia cohort ( $n = 435$ ) from one medical centre between 1988 and 1998 in Taiwan. Sixty oral carcinomas were ascertained in this cohort. A case-control study within the leukoplakia cohort was used to study risk factors. Using the Weibull survival model, the incidence of malignant transformation of leukoplakia was shown to increase with follow-up years. After adjustment for other relevant risk factors, betel nut chewing (adjusted odds ratio (OR) = 4.59; 95% confidence interval (CI) 1.25–16.86) remained a significant risk factor for malignant transformation. Results from the case-control study showed that the adjusted odds ratios for betel nut chewing and smoking on the occurrence of leukoplakia were 17.43 (95% CI 1.94–156.27) and 3.22 (95% CI 1.06–9.78), respectively. Similar findings were observed when daily frequency and duration were taken into account. This implies that cessation of smoking may reduce by 36% leukoplakia cases, while elimination of betel nuts may prevent 62% of leukoplakia and 26% of malignant transformation to oral carcinoma in the underlying population. © 2000 Cancer Research Campaign

**Keywords:** leukoplakia; oral cancer; betel nut chewing; smoking

In Taiwan, the mortality from oral cancer has increased from 3.6 per 1000 in 1971 to 6.4 per 100 000 in 1994. Prevention of oral cancer seems imperative. It is not feasible to detect oral cancers early (Silverman, 1988; Shanta and Krishnamurthi, 1980) and mass screening for oral cancer has not been recommended (Warnakulasuriya and Johnson, 1996). Primary prevention via programmes to eliminate risk factors may become important (Warnakulasuriya and Johnson, 1996). Previous studies have demonstrated that smoking was highly associated with leukoplakia (Bouquot, 1987; Roed-Petersen, 1982; Brugere et al, 1986; Evstifeeva and Zaridze, 1992) but whether betel nut – containing arecoline, lime and piper (one kind of pepper) – was significantly related to leukoplakia has not been fully addressed. Since the consumption of betel nut in Taiwan has been increasing, elucidation of any association is becoming increasingly important. The association between alcohol consumption and leukoplakia is also inconclusive (Blot et al, 1988; Brugere et al, 1986; Evstifeeva and Zaridze, 1992).

Previous studies have shown a wide range of rates of malignant transformation of leukoplakia (0.13–36.4%) (Pindborg et al, 1968; Roed-Petersen, 1971; Banoczy, 1977; Gupta et al, 1980; Silverman et al, 1984; Bouquot et al, 1988). This suggests that the impact of putative risk factors may vary between different populations. The aims of this study were (1) to evaluate the effects of betel nut chewing, smoking and alcohol use on the risk of leuko-

plakia, taking the daily frequency and the duration of three factors into account; and (2) to assess the impact of relevant risk factors on malignant transformation to oral carcinoma, using samples from certain Chinese people in Taiwan.

### MATERIALS AND METHODS

#### Study design and subject selection

According to the WHO definition, a clinical diagnosis of leukoplakia is a keratotic white plaque that cannot be scraped off and cannot be given another specific diagnosis. Oral cancer is classified by the ICD into categories of lip, tongue, gum, mouth floor, buccal, palate, oropharynx, hypopharynx (International Code of Disease, ICD 140–149, excluding 142–147).

A total of 580 cases of leukoplakia diagnosed between June 1988 and February 1998 at one medical centre in Taiwan were ascertained. Of these, 145 patients who were subsequently diagnosed as having lichen planus, oral ulcer, infection, oral candidiasis or skin leukoplakia were excluded leaving 435 subjects in the leukoplakia cohort on which two parts of this study were based (Figure 1). Part A was to follow up the leukoplakia cohort to estimate the incidence of malignant transformation and relevant risk factors. Of the 435 patients, 60 oral carcinomas were identified, among which only 4% had a different location from the leukoplakia. In order to study factors accounting for malignant transformation, information was abstracted from the medical chart on date of diagnosis, location of leukoplakia and risk factors at time of leukoplakia diagnosis, such as betel nut chewing, smoking and alcohol use. These variables were routinely recorded in the medical chart.

Part B was to elucidate the association between risk factors and leukoplakia using a matched case-control study. A total of 100

Received 1 September 1999

Revised 7 December 1999

Accepted 11 January 2000

Correspondence to: THH Chen, Graduate Institute of Epidemiology, College of Public Health, National Taiwan University, Room 213, No 19 Hsueh Road, Taipei, Taiwan

1046  
R

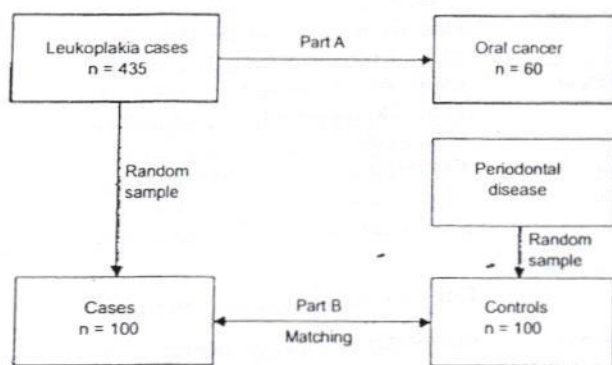

Figure 1 The study design on factors affecting the risk leukoplakia and malignant transformation

leukoplakia cases were randomly selected from the above leukoplakia cohort. Each case was matched to one control for age ( $\pm 3$  years), sex and date of diagnosis ( $\pm 3$  months) derived from a total of 25 882 patients with a diagnosis of periodontal diseases in the same period and hospital as the study group. All cases and controls were free of oral cancer. Since information on risk factors such as betel nut chewing, smoking and drinking for the control group could not be completely obtained from medical charts we collected information via telephone interview. We also interviewed 68 out of 100 leukoplakia case-control pairs to check whether information from the medical chart was consistent with that from telephone interview. Reasons for non-participation included: not at home after three calls, wrong telephone number and refusal. Each participant was asked to provide information on the three risk factors, categorized as: current, former and never. Duration and daily frequency for each risk factor were also collected. A product of duration and daily frequency was defined as the intensity for the current and the former groups. The high or low intensity was categorized according to the median value for each risk factor. It should be noted that since there was a variety of types and brands for the drinkers, it was very difficult to define the dose per day. For alcohol use, only information on daily frequency was asked in telephone interview.

#### Statistical methods

For Part A analysis, an accelerated failure time (AFT) model (Marubini and Valsecchi, 1995) was used to estimate the risk of malignant transformation and the association with the location of leukoplakia, betel nut chewing, smoking and drinking. Two parametric models including exponential and Weibull models were employed. All leukoplakia cases were followed until February 1998.

In the analysis of Part B, a conditional logistic regression was performed to investigate the relationship between betel nut chewing, smoking, alcohol drinking, and the occurrence of leukoplakia. The odds ratio (OR), together with exposure information derived from a previous population-based survey (Lee and Chen 1999), gave the population attributable proportion (PAR) for each risk factor (Breslow and Day 1980).

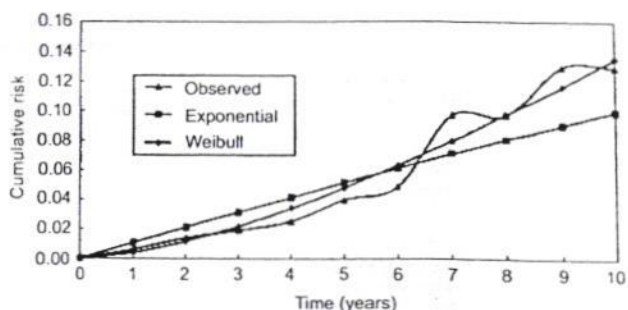

Figure 2 Cumulative risk of malignant transformation, the observed and predicted using the exponential model and the Weibull Model

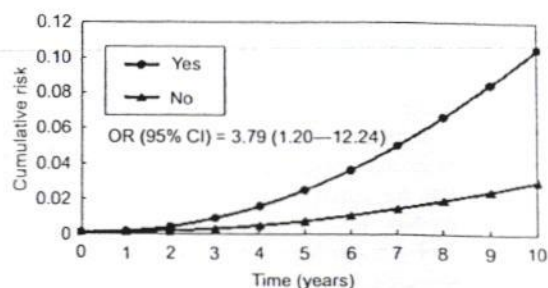

Figure 3 Cumulative risk of malignant transformation by betel nut chewing

## RESULTS

### Malignant transformation from leukoplakia to oral carcinoma

Figure 2 shows that the incidence of malignant transformation in patients with leukoplakia increases with duration of follow-up.

The univariate analysis based on the Weibull model examined whether risk of malignant transformation depends on betel nut chewing, smoking, alcohol use and location of leukoplakia. The cumulative risk stratified by these variables was calculated. Figure 3 reveals that those who chewed betel nut were nearly four times more likely to develop malignant transformation than those who did not (OR = 3.79, 95% confidence interval (CI) 1.20–12.24). Other significant factors influencing malignant transformation include location around the tongue (OR = 3.65, 95% CI 1.09–12.25) and smoking (OR = 2.34, 95% CI 0.62–8.93).

Results from the multivariate analysis (Table 1), which incorporates significant factors in the above univariate analysis plus age and sex, show that betel nut chewing still remains a significant risk for malignant transformation. The hazard ratio for chewing betel nut was 4.59 (95% CI 1.25–16.85) after adjustment for age and sex. However, the effect of smoking and location on malignant transformation is not significant after adjustment for other factors.

### Risk factors for leukoplakia

Table 2 shows that the group of current betel nut chewers had a 26-fold higher (95% CI 3.27–204.00) risk for leukoplakia than that of the 'never' group. The OR for the occurrence of leukoplakia in

1047  
2

**Table 1** Multivariate analysis of the impact of risk factors on the risk of malignant transformation in patients with leukoplakia, adjusted for age and sex using the Weibull regression model

Risk factors	Odds ratio	95% CI
Location		
Tongue	1.54	0.24-9.73
Buccal	0.30	0.05-1.72
Alveola+lip	0.57	0.06-5.83
Others	1	
Betel nut chewing		
Yes	4.59	1.25-16.86
No	1	
Cigarette smoking		
Yes	2.38	0.62-9.05
No	1	

the current smokers was 5.42 (95% CI 2.17-13.80). The frequent alcohol users had an ninefold (95% CI 1.11-68.7) risk for leukoplakia compared to 'never' group.

With respect to intensity, significant dose-response relationships were observed for three factors. For betel nut chewing, the risk for leukoplakia in the high intensity group (defined by a product of frequency and duration) was 32-fold (95% CI 2.44-408.00) higher than that in the 'never' group. The corresponding figure in the low intensity group was 16 (95% CI 1.37-137.00). As regards smoking, the high intensity group was five times more likely to develop leukoplakia than never smokers (95% CI 1.73-17.20), whereas the OR for the low intensity group compared with the never group was 3.68 (95% CI 1.20-11.20).

Table 3 presents the results of multivariate analysis after adjustment for the effect of the three variables on each other. The adjusted OR for chewing betel nut and smoking in the current group were 17.43 (95% CI 1.94-156.27) and 3.22 (95% CI 1.06-9.78) respectively. The adjusted OR for the use of betel nut and tobacco in the high intensity group were 22.49 (95% CI 1.44-351.42) and 3.09 (95% CI 0.93-10.34) respectively. The effect of alcohol on the occurrence of leukoplakia disappeared, after adjustment for betel nut chewing and smoking.

**Consistency of exposure information**

Consistency of exposure information between the medical chart and telephone interview was checked. A good agreement was demonstrated by Kappa statistics (all Kappa values greater than 0.6). To establish whether two different procedures for obtaining information may have affected the results, we estimated the adjusted odds ratios based on the two sources and no significantly different results were found.

**DISCUSSION**

A leukoplakia cohort study and the derived matched case-control were designed to elucidate the effect of betel nut chewing, smoking and alcohol use on the three-state natural history of oral cancer, from normal, through leukoplakia and to oral carcinoma. Results from this study had two major practical findings. First, chewing betel nut was demonstrated to influence not only the occurrence of leukoplakia but also its malignant transformation. Although smoking might play a major role in the occurrence of

**Table 2** Univariate analysis of the effect of cigarette smoking, betel nut chewing and alcohol use on the incidence of leukoplakia

Risk factor	Odds ratio (95% CI)					
	Never	Status classification			Intensity classification	
			Former	Current	Low	High
Cigarette smoking	1	2.03 (0.61-6.75)	5.42 (2.17-13.80)	3.68 (1.20-11.20)	5.45 (1.73-17.20)	
Betel nut chewing	1	3.78 (0.61-23.30)	25.85 (3.27-204.00)	15.61 (1.77-137.00)	31.55 (2.44-408.00)	
Alcohol use	Never 1	Occasional 0.63 (0.11-3.65)	Frequent 8.66 (1.11-68.70)			

**Table 3** Multivariate analysis of the effect of alcohol use, betel nut chewing and cigarette smoking on the incidence of leukoplakia, adjusted for the effects of three factors on each other

Risk factor	Odds ratio (95% CI)					
	Never	Status classification			Intensity classification	
			Former	Current	Low	High
Cigarette smoking	1	1.04 (0.24-4.59)	3.22 (1.06-9.78)	1.67 (0.45-6.26)	3.09 (0.93-10.30)	
Betel nuts chewing	1	2.38 (0.34-16.75)	17.43 (1.94-156.27)	9.06 (1.00-81.64)	22.49 (1.44-351.00)	
Alcohol use	Never 1	Occasional 0.28 (0.03-2.56)	Frequent 3.00 (0.27-33.50)			

1048  
A

leukoplakia, it may not be a main contributory cause for malignant transformation. If the prevalence of smoking and betel nut chewing among the general population are estimated as 26% and 10% (Lee and Chen, 1999), respectively, this information plus ORs reveals that eliminating the habit of betel nut chewing may reduce the occurrence of leukoplakia by 62% and reduce the rate of malignant transformation by 26% in the underlying population. The corresponding figures for the elimination of smoking were 36% and 26% respectively. Thus, a primary prevention program designed to discourage people from betel nut chewing and smoking seems crucial.

Second, as the likelihood ratio test between the exponential model (constant hazard) and the Weibull model (increasing hazard) was statistically significant ( $\chi^2_{(1)} = 4.30$ ,  $P = 0.038$ ) (Figure 2) this implies that the incidence of malignant transformation from leukoplakia increases with time. Increased risk associated with increasing duration after diagnosis was most marked for leukoplakia in subjects with the habit of betel nut chewing. This might reflect the fact that the proportion of leukoplakia among individuals who chew betel nut also increases year by year.

Few studies have reported on the association between betel nut chewing and leukoplakia or the effect of betel nut chewing on malignant transformation. Only Silverman et al (1984) reported a statistically significant relationship between Pan (a mixture of tobacco and betel nut) and malignant transformation. However, as chewing betel nut in our study did not involve a mixture of tobacco, it is difficult to compare our results with Silverman et al.

A significant positive association between smoking and leukoplakia is consistent with previous reports (Evstifeeva and Zaridze, 1992; Kulasegaram et al, 1995). Our finding of a dose-response relationship is also in agreement with the study by Kulasegaram et al (1995).

The increased risk of malignant transformation with time in this study is at odds with the previous report that this decreased with time (Silverman et al, 1984). Three possibilities may be relevant. First, the histological distribution of leukoplakia in this study may be different. A persistence of betel nut chewing in leukoplakia cases in Taiwan may provide a second explanation. Third, different treatments might also affect the rate of transformation.

With respect to malignant transformation, only 4% of our leukoplakia cases did not have the same location as oral carcinoma. Such cancers may originate from other sites of leukoplakia but their small number is unlikely to have affected the results.

In conclusion, this study finds that betel nut chewing is a major risk factor not only for the occurrence of leukoplakia but also for malignant transformation. We estimate that elimination of betel nut chewing would prevent 62% of leukoplakia and 26% of malignant transformation.

#### REFERENCES

- Banoczy J (1977) Follow-up studies in oral leukoplakia. *J Maxillofac Surg* 5: 69-75
- Blot WJ, McLaughlin JK, Winn DM, et al (1988) Smoking and drinking in relation to oral and pharyngeal cancer. *Cancer Res* 48: 3282-3287
- Bouquot JE (1987) Epidemiology. In: *Pathology of the Head and Neck*, Gnepp DG (ed), Churchill Livingstone: New York; pp. 263-314
- Bouquot JE, Weiland LH and Kurland LT (1988) Leukoplakia and carcinoma in situ synchronously associated with invasive oral/oropharyngeal carcinoma in Rochester, Minn, 1935-1984. *Oral Surg Oral Med Oral Path* 65: 199-207
- Breslow NE and Day NE (1980) Statistical methods in cancer research. volume 1 The analysis of case-control studies. International Agency for Research on Cancer, Lyon; p. 74
- Brugere J, Guenel P, Leclerc A and Rodriguez J (1986) Differential effects of tobacco and alcohol in cancer of the larynx, pharynx and mouth. *Cancer* 57: 391-395
- Evstifeeva TV and Zaridze DG (1992) Nass use, cigarette smoking, alcohol consumption and risk of oral and oesophageal precancer. *Eur J Cancer* 28B: 29-35
- Gupta PC, Mehta FS, Daftary DK et al (1980) Incidence rates of oral cancer and natural history of oral precancerous lesions in a 10-year follow-up study of Indian villagers. *Community Dent Oral Epidemiol* 8: 283-333
- Kulasegaram R, Downer MC, Jullien JA, Zakrzewska JM and Speight PM (1995) Case-control study of oral dysplasia and risk habits among patients of a dental hospital. *Eur J Cancer* 31B: 227-231
- Lee L and Chen HH (1999) A survey of smoking and betel nut chewing in Taiwan. Technique report of the bureau of health promotion and protection DOH(DOH88-HP-Tobac03)
- Marubini E and Valsecchi MG (1995) *Analysing Survival Data from Clinical Trials and Observational Studies*, pp. 267-292 John Wiley: London
- Pindborg JJ, Jolst O, Renstrup G and Roed-Petersen B (1968) Studies in oral leukoplakia: a preliminary report on the period prevalence of malignant transformation in leukoplakia based on a follow-up study of 248 patients. *J Am Dent Assoc* 76: 767-771
- Roed-Petersen B (1971) Cancer development in oral leukoplakia: Follow-up of 331 patients. *J Dent Res* 50: 711
- Roed-Petersen B (1982) Effect on oral leukoplakia of reducing or ceasing tobacco smoking. *Acta Dermato-Venerol* 62: 164-167
- Shanta V and Krishnamurthi S (1980) Combined bleomycin and radiotherapy in oral cancer. *Clinical Radiology* 31: 617-620
- Silverman SJ (1988) Early diagnosis of oral cancer. *Cancer* 62: 1796-1799
- Silverman SJ, Gorsky M and Lozada F (1984) Oral leukoplakia and malignant transformation: A follow-up study of 257 patients. *Cancer* 53: 563-568
- Warnakulasuriya KA and Johnson NW (1996) Strengths and weaknesses of screening programmes for oral malignancies and potentially malignant lesions. *Eur J Cancer Prev* 5: 93-98
- WHO Collaborating Centre for Oral Precancerous Lesions (1978) Definition of leukoplakia and related lesions: an aid to studies in oral precancer. *Oral Surg, Oral Medicine, Oral Pathol* 46: 518-539

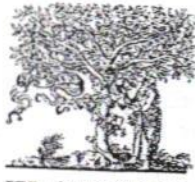

ELSEVIER

available at [www.sciencedirect.com](http://www.sciencedirect.com)

SCIENCE @ DIRECT®

journal homepage: <http://intl.elsevierhealth.com/journals/oron/>

ORAL  
ONCOLOGY

REVIEW

# Oral submucous fibrosis: Review on aetiology and pathogenesis

W.M. Tilakaratne<sup>a,b,c</sup>, M.F. Klinikowski<sup>d</sup>, Takashi Saku<sup>c</sup>,  
T.J. Peters<sup>e</sup>, Saman Warnakulasuriya<sup>d,\*</sup>

<sup>a</sup> The Centre for Research in Clinical and Diagnostic Oral Sciences, School of Medicine and Dentistry, Barts and The London, London, UK

<sup>b</sup> Department of Oral Pathology, Faculty of Dental Sciences, University of Peradeniya, Sri Lanka

<sup>c</sup> Division of Oral Pathology, Niigata University Graduate School of Medical and Dental Sciences, Niigata, Japan

<sup>d</sup> Department of Oral Medicine and Pathology, WHO Collaborating Centre for Oral Cancer and Precancer, Guy's, King's and St. Thomas' Dental Institute, King's College, Caldecot Road, London SE5 9RW, UK

<sup>e</sup> Formerly Clinical Biochemistry, King's College, London, UK

Received 26 July 2005; accepted 9 August 2005

## KEYWORDS

Areca nut;  
Arecoline;  
Cytokines;  
Oral submucous fibrosis;  
Mechanisms;  
Pathogenesis

**Summary** Data from recent epidemiological studies provide overwhelming evidence that areca nut is the main aetiological factor for OSF. A clear dose-dependent relationship was observed for both frequency and duration of chewing areca nut (without tobacco) in the development of OSF. Commercially freeze dried products such as pan masala, Guthka and mawa (areca and lime) have high concentrates of areca nut per chew and appear to cause OSF more rapidly than by self prepared conventional betel quid that contain smaller amounts of areca nut. It is logical to hypothesise that the increased collagen synthesis or reduced collagen degradation as possible mechanisms in the development of the disease. There are numerous biological pathways involved in the above processes and, it is likely that the normal regulatory mechanisms are either down regulated or up regulated at different stages of the disease. Among the chemical constituents, alkaloids from areca nut are the most important biologically whilst tannin may have a synergistic role. These chemicals appear to interfere with the molecular processes of deposition and/or degradation of extracellular matrix molecules such as collagen. In vitro studies on human fibroblasts using areca extracts or chemically purified arecoline support the theory of fibroblastic proliferation and increased collagen formation that is also demonstrable histologically in human OSF tissues. The copper content of areca nut is high and the possible role of copper as a mediator of fibrosis is supported by the demonstration of up regulation of lysyl oxidase in OSF biopsies. It has been postulated that areca nut may also

\* Corresponding author. Tel.: +20 7346 3608; fax: +20 7346 3624.  
E-mail address: [s.warne@kcl.ac.uk](mailto:s.warne@kcl.ac.uk) (S. Warnakulasuriya).

1050

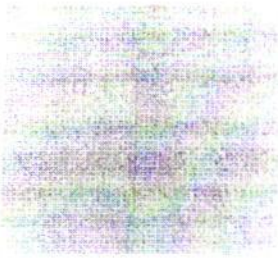

induce the development of the disease by increased levels of cytokines in the lamina propria. Increased and continuous deposition of extracellular matrix may take place as a result of disruption of the equilibrium between matrix metalloproteinases (MMPs) and tissue inhibitors of matrix metalloproteinases (TIMP). Current evidence implicates collagen-related genes in the susceptibility and pathogenesis of OSF. The individual mechanisms operating at various stages of the disease—initial, intermediate and advanced—need further study in order to propose appropriate therapeutic interventions.

© 2005 Elsevier Ltd. All rights reserved.

## Introduction

Oral submucous fibrosis (OSF), first described in the early 1950s, is a potentially malignant disease predominantly seen in people of Asian descent. It is a chronic progressive disorder and its clinical presentation depends on the stage of the disease at detection. The majority of patients present with an intolerance to spicy food, rigidity of lip, tongue and palate leading to varying degrees of limitation of opening of the mouth and tongue movement. The hallmark of the disease is submucosal fibrosis that affects most parts of the oral cavity, pharynx and upper third of the oesophagus. The disease is predominantly seen in India, Bangladesh, Sri Lanka, Pakistan, Taiwan, Southern China, Polynesia and Micronesia. Several case-series are reported among Asian immigrants to the UK and South and East Africa. A significant variation in the prevalence of OSF in different countries has been reported.<sup>1</sup>

Recent epidemiological data indicates that, the number of cases of OSF has risen rapidly in India from an estimated 250,000 cases in 1980 to 2 million cases in 1993. The reasons for the rapid increase of the disease are reported to be due to an upsurge in the popularity of commercially prepared areca nut preparations (pan masala) in India<sup>2</sup> and an increased uptake of this habit by young people<sup>3</sup> due to easy access, effective price changes and marketing strategies.

The aim of this review is to analyze critically the recent developments that may lead to our understanding of the aetiology and pathogenesis of OSF with special reference to areca nut as the major aetiological factor.

When the disease was first described in 1952, it was classified as an idiopathic disorder.<sup>4</sup> However, researchers started to implicate various environmental agents as likely aetiological factors. The factors that have been discussed as possible aetiological factors to date are areca nut, capsaicin in chillies, micronutrient deficiencies of iron, zinc and essential vitamins. In addition, a possible autoimmune basis to the disease with demonstration of various auto-antibodies and an association with specific HLA antigens has been proposed. This raises the possibility of a genetic predisposition of some individuals to develop OSF. However, from the available scientific literature, it is clear that the regular use of areca nut is the major aetiological factor.<sup>1</sup> It is interesting to note that only a single paper in the literature, describes a few cases of OSF developing without any areca nut chewing habit<sup>5</sup> that could be accounted for by denial of the habit. Taking into account, atrophy as the underlying factor, an alternative pathway related to undernutrition has

been proposed.<sup>6</sup> This is more likely to cause a confounding effect on the disease rather than its primary cause.

## Aetiology

A number of epidemiological surveys, case-series reports, large sized cross sectional surveys, case-control studies, cohort and intervention studies provide over whelming evidence that areca nut is the main aetiological factor for OSF.<sup>1,2,7–15</sup> Most convincing evidence is derived from case-control studies that estimate the odds ratios for areca nut use among oral submucous fibrosis cases and a definite dose-dependent relationship between areca nut and causation of the disease. Daily use appeared to be more important than the duration of the habit.<sup>9</sup> A recent case-control study showed that the risk of developing OSF was almost double for subjects below 21 years of age compared with that for the 21–40 year age group; the younger group developed features of OSF in 3.5 years whilst the older group took 6.5 years from the start of the habit.<sup>2</sup> In a recent study, a clear dose-dependent relationship was observed for both frequency and duration of chewing areca nut (without tobacco) in the development of OSF.<sup>15</sup> The severity and the time taken for the development of the disease may also vary according to the preparation of areca nut consumed. The commercially freeze dried products such as pan masala, Guthka and mawa (areca and lime) have high concentrates of areca nut per chew and appear to cause OSF more rapidly than by self prepared conventional betel quid which contain smaller amounts of areca nut.<sup>12,14</sup>

## Pathogenesis

The role of the constituents of areca nut in the pathogenesis of OSF has been studied in detail over the last two decades. It is apparent that fibrosis and hyalinization of sub epithelial tissues account for most of the clinical features encountered in this condition. Moreover, substantial amount of research on elucidating the aetiology and pathogenesis appear to have been focused on changes in the extracellular matrix (ECM). It is logical to hypothesise that the increased collagen synthesis or reduced collagen degradation as possible mechanisms in the development of the disease. There are numerous biological pathways involved in the above processes and, it is likely that the normal regulatory mechanisms are either down regulated or up regulated at different stages of the disease.

1051  
A

### Areca alkaloids causing fibroblast proliferation and increased collagen synthesis

It is apparent that among the chemical constituents, alkaloids from areca nut are the most important biologically. Four alkaloids have been conclusively identified in biochemical studies, arecoline, arecaidine, guvacine, guvacoline, of which arecoline is the main agent. *In vitro* studies on human fibroblasts using areca extracts or chemically purified arecoline support the theory of fibroblastic proliferation and increased collagen formation that is also demonstrable histologically in human OSF tissues.<sup>16</sup> Hydrolysis of arecoline produces arecaidine that has pronounced effects on fibroblasts.<sup>16</sup> Arecoline in high doses such as 100 µg ml<sup>-1</sup> was cytotoxic and cells showed detachment from the culture surface. There was a concentration-dependent stimulation of collagen synthesis when fibroblasts were exposed to both arecoline and arecaidine. However, the stimulation was always greater with arecaidine. In addition, it was evident that the correlation between the hydrolysis rates of different esters and the extent to which they stimulate collagen synthesis, suggest that hydrolysis of arecoline into arecaidine is necessary before fibroblast stimulation can occur.<sup>16</sup> This suggests that arecaidine is the active metabolite in fibroblast stimulation. This view was further supported by the finding that, addition of slaked lime (Ca(OH)<sub>2</sub>) to areca nut in pan facilitates hydrolysis of arecoline to arecaidine making this agent available in the oral environment.<sup>17</sup> Examination of the effects of arecoline on both normal and OSF fibroblasts in culture revealed an elevated rate of collagen synthesis by OSF fibroblasts compared with normal fibroblasts. Although the reason for this elevation is not clear, the authors proposed that it could reflect the clonal selection of a cell population in the altered tissues under the influence of local factors such as interleukin-1 from inflammatory cells.<sup>18</sup>

### Stabilization of collagen structure by tannins (and catechins polyphenols)

One of the mechanisms that can lead to increased fibrosis is by reduced degradation of collagen by forming a more stable collagen structure. Treatment of reconstituted collagen fibrils and pieces of rat dermis with crude extracts of the nut or purified tannins from areca nut increased their resistance to both human and bacterial collagenases in a concentration-dependent manner.<sup>19</sup> The same mechanism may operate in patients with OSF causing fibrosis below the damaged oral epithelium.

This evidence was also supported by another study which showed that the ability of large quantities of tannin present in areca nut reduced collagen degradation by inhibiting collagenases and proposed the basis for fibrosis as the combined effect of tannin and arecoline by reducing degradation and increased production of collagen respectively.<sup>20</sup> Collagenase activity was measured with soluble 14C-glycine-labeled collagen as a substrate and showed reduced activity in fibroblasts from OSF compared with controls. Further, they confirmed that the cleavage pattern of

the collagen is similar to that of typical mammalian collagen.<sup>21</sup> Another study using cell culture methodology showed that there was a 1.5-fold increase in collagen production in OSF fibroblasts with a ratio of type I to type III collagens similar to normal fibroblasts. In contrast, recent work from our laboratory reveals that with the progression of the disease type III collagen is almost completely replaced by type I.<sup>22</sup> It was postulated that the reason for high level of collagen production in OSF because these fibroblasts are a subset with increased potential for proliferation among heterogeneous fibroblasts.<sup>23</sup> However, that may not be the only reason for increased collagen as some fibroblast strains isolated from OSF failed to show—the same phenomena. An important finding from the above study was the identification of excess α1(1) chains relative to α2(I) suggesting an alteration of collagen molecules during the progression of the disease. Although, the biological function of this trimer is not known, it is regarded as more resistant to degradation than the normal collagen molecule.<sup>24</sup>

### Copper in nut and fibrosis

The copper content of areca nut is high and the levels of soluble copper in saliva may rise in volunteers who chew areca nut.<sup>25</sup> The same group showed that the oral mucosa of areca nut chewers had significantly raised levels of copper when compared with the control subjects.<sup>26</sup> The association between copper and OSF has been linked on the basis that excess copper is found in tissues of other fibrotic disorders—Wilson's disease, Indian childhood cirrhosis and primary biliary cirrhosis. The enzyme lysyl oxidase is found to be upregulated in OSF.<sup>27</sup> This is a copper dependent enzyme<sup>28</sup> and plays a key role in collagen synthesis and its cross linkage. The possible role of copper as a mediator of fibrosis is supported by the demonstration of up regulation of this enzyme in OSF biopsies<sup>27</sup> and in OSF fibroblasts compared to normal fibroblasts grown in culture.<sup>29</sup> Copper added at various concentrations *in vitro* has also been shown to increase proliferation of fibroblasts in culture.<sup>30</sup> The fibroblasts in OSF have not only increased lysyl oxidase activities but also specific growth characteristics. This was evident with the reported cell doubling time of 3.2 days for OSF and 3.6 days for normal fibroblasts.<sup>29</sup> Further, OSF fibroblasts grew more rapidly than normal as the former became confluent in 5 days compared to 6 days for the latter. However, another study based on ultrasound investigations of visceral organs in OSF patients reported that there was no evidence of fibrotic changes elsewhere. Faecal copper was also normal suggesting that the copper levels were within the tolerance levels.<sup>31</sup> As the oral mucosa is directly exposed to the copper challenge in chewers its effect may well be local. These different growth characteristics may either be due to the direct effects of ingredients of areca nut or secondary to inflammatory factors mediated by areca nut such as IL-1, TGF-β, IGF, EGF.<sup>32</sup>

### Upregulation of cyclo-oxygenase (Cox-2)

It is known that OSF is associated with inflammatory changes in at least some stages of the disease. Prostaglandin is one of

1052

the main inflammatory mediators and its production is controlled by various enzymes such as cyclooxygenase (COX). Biopsies from buccal mucosa of OSF cases and from controls were stained for COX-2 by immunohistochemistry and revealed that there was increased expression of the enzyme in moderate fibrosis and this disappeared in advanced fibrosis. This finding is compatible with the histology of the disease as there is lack of inflammation in the advanced disease. The above finding was confirmed by treating buccal mucosal fibroblasts with 80 µg/ml arecoline in culture and revealed that COX-2 expression was up-regulated as early as half an hour, indicating this to be an early cellular response to arecoline at transcriptional level. COX-2 expression started to decrease when the arecoline concentration was increased upto 160 µg/ml, and this may be due to cytotoxicity.<sup>33</sup> Similar data have been reported in another study quoting 1.4–3.4-fold increase of PGE<sub>2</sub> production and 1.1–1.7-fold increase of PGE<sub>1α</sub> when gingival keratinocytes were exposed to areca nut extracts.<sup>34</sup>

### Fibrogenic cytokines

Changes in cytokine secretion in OSF have been investigated.<sup>32,35</sup> Endothelin and TGF β-1 estimated by radioimmunoassay and ELISA respectively were increased in OSF fibroblasts compared to fibroblasts of normal individuals. Therefore, it has been postulated that external stimuli such as areca nut may induce the development of the disease by increased levels of cytokines in the lamina propria. Another study compared spontaneous and stimulated production of cytokines by peripheral blood mononuclear cells from OSF patients with those of genetically related control subjects. They were able to demonstrate increased levels of pro-inflammatory cytokines and reduced anti-fibrotic IFN-γ in patients with the disease. These may be important events in the pathogenesis of OSF.<sup>32</sup> Subsequently, the same group using immunohistochemistry showed little or no expression of IFN-γ expression in biopsies from OSF tissues compared with normal controls. This finding is interesting as the same phenomenon is evident in systemic sclerosis. Up-regulation of pro-inflammatory cytokines such as interleukin 1 and 6 were clearly evident. The most important finding in the above study was the demonstration of increased expression of fibrogenic cytokines namely TGF-β, platelet derived growth factor (PDGF) and basic fibroblast growth factor (bFGF) in OSF tissues compared to normal.<sup>36</sup> These observations may suggest that the disease process in OSF may be an altered version of wound healing as our recent findings show that the expression of various ECM molecules are similar to those seen in maturation of granulation tissue.<sup>22</sup>

### Genetic polymorphisms predisposing to OSF

Polymorphisms of the genes coding for TNF-α has been reported as a significant risk factor for OSF. A study of 809 patients with OSF has revealed that the high production allele TNF2, to be significantly lower compared to an areca chewing control group.<sup>37</sup> TNF-α is known to stimulate fibroblastic proliferation *in vitro*<sup>38</sup> providing evidence for an active role for TNF-α in the pathogenesis of OSF. In another study a pos-

sible relationship existed between the major histocompatibility complex class I chain related gene A (MICA) and OSF. They showed that phenotype frequency of allele A6 of MICA in test subjects was significantly higher than the controls.<sup>39</sup> Some genotypes of cytotoxic T-lymphocyte associated antigen 4 (CTLA-4), a negative regulator of T-lymphocyte activation seems to have a susceptibility for various autoimmune diseases. Interestingly, the G allele at position +49 of exon 1 was found to be significantly associated with OSF compared with controls.<sup>40</sup> Whether the above findings drive the pathogenesis of OSF towards an autoimmune basis needs to be further investigated.

### Inhibition of collagen phagocytosis

Degradation of collagen by fibroblast phagocytosis is an important pathway of physiological remodelling of the extracellular matrix (ECM) in connective tissue. As OSF shows a gross imbalance in ECM remodeling, this putative mechanism was investigated *in vitro*. Fibroblasts from OSF patients and controls were incubated with collagen beads and found that the proportion of phagocytic cells to be 35% and 75% respectively. After incubation with fibronectin coated beads, normal fibroblasts exhibited 70% internalization whilst OSF fibroblast revealed 22% internalization. They also showed that the reduction of phagocytic cells was strongly related to the arecoline levels in fibroblast culture.<sup>41</sup> Interestingly, there was a dose-dependent enhancement of phagocytic cells when the cultures were treated with corticosteroids. In another study, reduced collagen phagocytosis by fibroblasts was inversely dose-dependent to the levels of arecoline, safrole and nicotine.<sup>42</sup>

### Stabilization of extracellular matrix

Increased and continuous deposition of extracellular matrix may take place as a result of disruption of the equilibrium between matrix metalloproteinases (MMPs) and tissue inhibitors of matrix metalloproteinases (TIMP). When normal (control) fibroblasts and fibroblasts from OSF patients were subjected to arecoline and arecadine in culture, OSF fibroblasts produced more TIMP-1 protein than normal fibroblasts; mRNA expression of TIMP-1 in OSF fibroblasts was also higher.<sup>43</sup> With the above data the authors suggested that TIMP-1 expression is increased at transcriptional level. Another recent study reports that the main gelatinolytic proteins secreted by buccal fibroblasts (MMP-2 and MMP-9) are found in minimal amounts in diseased tissues. The study further showed that arecoline reduced the MMP-2 secretion and increased the TIMP-1 levels resulting in increased deposition of collagen in the extracellular matrix.<sup>44</sup>

Although the main pathological change present in OSF appears to be markedly increased production of extra cellular matrix (ECM), there is little information on the actual remodeling of connective tissue with the progression of the disease. In a study in our laboratory in an attempt to investigate the remodeling of ECM in OSF, the patterns of expression of several molecules were investigated in various phases of the disease. It was apparent that the expression of tenascin disappeared when the lesion advanced from

1053

early to intermediate phase. Heparan sulphate proteoglycans (perlecan), fibronectin, type III collagen and elastin appeared in the early and intermediate phases but there was complete replacement by collagen type I when the lesion progressed to an advanced phase. The pattern of expression of most of these molecules followed a similar pattern to the organization of granulation tissue.<sup>45</sup>

### Collagen-related genes

Collagen-related genes play an important role in the homeostasis of collagen in the body. As OSF is a disease with dysregulation of collagen metabolism, it is important to identify the enzymes and various other molecules that may contribute to genetic modulation during the progression of the disease. Different (types of) enzymes such as collagenases and lysyl oxidase together with cytokines, namely TGF- $\beta$  have been implicated in this context. There is evidence to suggest that collagen-related genes are altered due to ingredients in the quid.<sup>46</sup> The genes COL1A2, COL3A1, COL6A1, COL6A3 and COL7A1 have been identified as definite TGF- $\beta$  targets and induced in fibroblasts at early stages of the disease. The transcriptional activation of procollagen genes by TGF- $\beta$  suggests that it may contribute to increased collagen levels in OSF.<sup>46</sup> Chiu et al.<sup>47</sup> analyzed two groups of betel chewers, one with OSF and the other without in order to compare the association of OSF and polymorphisms of six collagen related genes. They found that genotypes associated with highest OSF risk for collagen 1A1, collagen 1A2, collagenase-1, TGF- $\beta$ 1, lysyl oxidase and cystatin C were CC, AA, TT, CC, AA, and AA, respectively in the low-exposure group whilst TT, BB, AA, CC, GG, and AA, respectively for the high-exposure group. Current evidence implicates collagen-related genes in the susceptibility and pathogenesis of OSF.

### OSF as an autoimmune disorder

Autoimmunity as an aetiological factor for OSF has been examined. The reasons for investigating an autoimmune basis, included, slight female predilection and occurrence in the middle age reported in some studies,<sup>48,49</sup> the presence of circulating immune complexes, their immunoglobulin contents and the detection of various autoantibodies in patients' sera.<sup>49-55</sup> The presence of various autoantibodies at varying titres was reported in several studies suggesting the possibility of an autoimmune basis to the disease. The first report on this concept came in 1986 showing 65% of the sample being positive for at least one of the autoantibodies tested.<sup>49</sup> The antibodies which showed increased frequencies were, 38% anti gastric-parietal cell (GPCA), 23% anti thyroid microsomal, 8% anti-nuclear (ANA), 4% anti-reticulin and 4% anti smooth muscle (SMA) antibodies. However there was no control group included in the above study. In another study, it was revealed that ANA (23.9%), SMA (23.9%) and GPCA (14.7%) were positive in OSF patients compared with healthy control subjects.<sup>51</sup> Increased levels of immune complexes and raised serum levels of IgG, IgA and IgM when compared with control groups have also been reported.<sup>52-55</sup>

Few studies reported on HLA typing in OSF patients. The frequencies of HLA A10, DR3 and DR7 proved to be significantly different compared with an ethnically, regionally and age-matched control group.<sup>56</sup> Further, haplotypic pairs A10/DR3, A10/B8 and B8/DR3 showed an increased frequency in OSF patients compared to controls, although the differences were not statistically significant.<sup>50</sup> Another study using polymerase chain reaction (PCR) has shown a significant increase in frequencies of HLA A24, DRB 1-11 and DRB3-0202/3.<sup>57</sup> A recent study has revealed higher haplotype frequencies in pairs HLA B51/Cw7 and B62/Cw7 in OSF patients.<sup>58</sup> Two new HLA DRB1 alleles were identified by sequencing-based typing and named as HLA DRB1-0903 and DRB1-1145.<sup>59</sup> The association of HLA and OSF does not appear consistently as one study showed that there was no demonstrable specific pattern of HLA antigen frequencies in chewers with or without the disease.<sup>60</sup> Although the data on various HLA types, raised autoantibodies and the detection of immune complexes tend to indicate an autoimmune basis for the disease, substantial number of cases and matched controls may be required to verify these findings.

### Precancerous nature and malignant transformation

The precancerous nature of OSF was first described by Paymaster in 1956 when he observed slow growing squamous cell carcinoma (SCC) in one third of the patients with the disease.<sup>61</sup> This was confirmed by various groups and Pindborg in 1972 put forward five criteria to prove that the disease is precancerous.<sup>62</sup> They included, high occurrence of OSF in oral cancer patients, higher incidence of SCC in patients with OSF, histological diagnosis of cancer without any clinical suspicion in OSF, high frequency of epithelial dysplasia and higher prevalence of leukoplakia among OSF cases.<sup>63</sup> Most of the earlier studies have focused on the prevalence of epithelial dysplasia in OSF. It has so far been the most reliable indicator for predicting potential malignant transformation of an oral precancerous lesion though new markers are emerging.<sup>64</sup> Epithelial dysplasia in OSF tissues appeared to vary from 7 to 26% depending on the study population.<sup>65-67</sup> However, according to the current awareness of the disease and some refined criteria for grading dysplasia, it is reasonable to assume that the prevalence of dysplasia is more towards the midway of the reported range. Malignant transformation rate of OSF was found to be in the range of 7-13%. According to long term follow-up studies a transformation rate of 7.6% over a period of 17 years was reported.<sup>66</sup> Recently, the carcinogenicity of areca nut without tobacco was identified,<sup>68,69</sup> and the second IARC monograph on betel quid has classified areca nut as a 'group one carcinogen' based on epidemiologic and laboratory studies.<sup>1</sup> The strong association of areca nut with OSF, its dose-dependant effects<sup>10,70</sup> and the confirmation of OSF as a potentially malignant disease<sup>71</sup> leading to oral cancer provided further evidence for this assertion. We hypothesise that dense fibrosis and less vascularity of the corium, in the presence of an altered cytokine activity creates a unique environment for carcinogens from both

1054

tobacco and areca nut to act on the epithelium. It could be assumed that carcinogens from areca nut accumulate over a long period of time either on or immediately below the epithelium allowing the carcinogens to act for a longer duration before it diffuses into deeper tissues. Less vascularity may deny the quick absorption of carcinogens into the systemic circulation.

## Conclusions

In summary, the available literature indicates that the main aetiological factors for OSF are the constituents of areca nut, mainly arecoline, whilst tannin may have a synergistic role. These chemicals appear to interfere with the molecular processes of deposition and/or degradation of extracellular matrix molecules such as collagen, causing imbalance in the normal process. The most likely events that take place with regards to the above imbalance may be reduced phagocytosis of collagen by fibroblasts, up or down regulation of key enzymes such as lysyl oxidase, matrix metalloproteinases and tissue inhibitors of matrix metalloproteinases. The process may also be influenced by increased secretion of inflammatory cytokines, growth factors and decreased production of anti-fibrotic cytokines. Although the above mechanisms may explain the induction, maintenance and progression of fibrosis in OSF, further research is required in order to identify the mechanism leading to carcinogenesis in this fibrotic oral mucosa. Nutritional deficiencies may not play a primary role but it could synergise the symptomatology by contributing to epithelial atrophy. Although the involvement of HLA and genetic predisposition has been reported, specific haplotypes have not been determined.

The individual mechanisms operating at various stages of the disease—initial, intermediate and advanced—need further study in order to propose appropriate therapeutic interventions.

## References

- International Agency for Research on Cancer. Betel-quid and areca nut chewing and some areca nut derived nitrosoamines, vol. 85. Lyon: IARC; 2004. p. 123–9.
- Ranganathan K, Uma Devi M, Joshua E, Kirankumar K, Saraswathi TR. Oral submucous fibrosis: a case control study in Chennai South India. *J Oral Pathol Med* 2004;33:274–7.
- Gupta PC, Sinor PN, Bhonsle RB, Pawar VS, Mehta HC. Oral submucous fibrosis in India: a new epidemic. *Natl Med J India* 1998;11:113–6.
- Schwartz J. Atrophia idiopathica tropica mucosa oris. In: Proceedings of the 11th International Dental Congress in London, 1952, July.
- Seedat HA, Van Wyk CW. Submucous fibrosis in non-betel nut chewing subjects. *J Biol Buccale* 1988;16:3–6.
- Rajendran R, Vijayakumar T, Vasudevan DM. An alternative pathogenic pathway for oral submucous fibrosis. *Med Hypotheses* 1989;30:35–7.
- Yang YH, Lee HY, Tung S, Shieh TY. Epidemiological survey of oral submucous fibrosis and leukoplakia in aborigines of Taiwan. *J Oral Pathol Med* 2001;30:213–9.
- Seedat HA, Van Wyk CW. Betel nut chewing and oral submucous fibrosis in Durban. *S Afr Med J* 1988;74:572–5.
- Maher R, Lee AJ, Warnakulasuriya KA, Lewis JA, Johnson NW. Role of areca nut in the causation of oral submucous fibrosis: a case control study in Pakistan. *J Oral Pathol Med* 1994;23:65–9.
- Murti PR, Bhonsle RB, Gupta PC, Daftary DK, Pindborg JJ, Mehta FS. Aetiology of oral submucous fibrosis with special reference to the role of areca nut chewing. *J Oral Pathol Med* 1995;24:145–52.
- Farrand P, Rowe RM, Johnston A, Murdoch H. Prevalence, age of onset and demographic relationships of different areca nut habits amongst children in Tower Hamlets, London. *Br Dent J* 2001;190:150–4.
- Shah N, Sharma PP. Role of chewing and smoking habits in the aetiology of oral submucous fibrosis (OSF): a case control study. *J Oral Pathol Med* 1998;27:475–9.
- Merchant AT, Haider SM, Fikree FF. Increased severity of oral submucous fibrosis in young Pakistani men. *Br J Oral Maxillofac Surg* 1997;35:284–7.
- Sinor PN, Gupta PC, Murti PR, Bhonsle RB, Daftary DK, Mehta FS, et al. A case-control study of oral submucous fibrosis with special reference to the aetiological role of areca nut. *J Oral Pathol Med* 1990;19:94–8.
- Jacob BJ, Straif K, Thomas G, Ramadas K, Mathew B, Zhang ZF, et al. Betel quid without tobacco as a risk factor for oral precancers. *Oral Oncol* 2004;40:697–704.
- Harvey W, Scutt A, Meghji S, Canniff P. Stimulation of human buccal mucosa fibroblasts in vitro by betel nut alkaloids. *Arch Oral Biol* 1986;31:45–9.
- Nieschultz V, Schmersahl P. Zur Pharmakologie der Wirkstoffe des Betels Umwenlung des arecolin in arecadin. *Arzneimittel-Forsch* 1968;18:222–5.
- Meghji S, Scutt A, Harvey W, Canniff JP. An in vitro comparison of human fibroblasts from normal and oral submucous fibrosis tissue. *Arch Oral Biol* 1987;32:213–5.
- Scutt A, Meghji S, Canniff JP, Harvey W. Stabilisation of collagen by betel nut polyphenols as a mechanism in oral submucous fibrosis. *Experientia* 1987;43:391–3.
- Meghji S, Scutt A, Canniff JP, Harvey W, Phillipson JD. Inhibition of collagenase activity by areca nut tannins: a mechanism of collagen accumulation in oral submucous fibrosis? *J Dent Res* 1982;61:545.
- Shieh TY, Yang JF. Collagenase activity in oral submucous fibrosis. *Pro Natl Sci Councl China B* 1992;16:106–10.
- Utsunomiya H, Tilakaratne WM, Oshiro K, Maruyama S, Suzuki M, Ida-Yonemochi M, et al. Extracellular matrix remodeling in oral submucous fibrosis; its stage-specific modes revealed by immuno-histochemistry and in-situ hybridization. *J Oral Pathol Med* 2005;34:498–507.
- Kuo MYP, Chen HM, Hahn LJ, Hsieh CC, Chiang CP. Collagen biosynthesis in human oral submucous fibrosis fibroblast cultures. *J Dent Res* 1995;74:1783–8.
- Narayanan AS, Meyers DF, Page RC, Welgus HG. Action of mammalian collagenase of type I trimer collagen. *Collagen Rel Res* 1984;4:289–96.
- Trivedy C, Warnakulasuriya KAAS, Johnson NW, Peters TJ. Copper content in areca catechu products and oral submucous fibrosis. *Lancet* 1997;340:1447.
- Trivedy CR, Warnakulasuriya KAAS, Peters TJ, Senkus R, Hazarey VK, Johnson NW. Raised tissue copper levels in oral submucous fibrosis. *J Oral Pathol Med* 2000;29:241–8.
- Trivedy CR, Warnakulasuriya KAAS, Hazarey VK, Tavassoli M, Sommer P, Johnson NW. The upregulation of lysyl oxidase in oral submucous fibrosis and squamous cell carcinoma. *J Oral Med Pathol* 1999;28:246–51.
- Kagen HM, Trackenman PC. Properties and function of lysyl oxidase. *Am J Respir Cell Mol Biol* 1991;5:206–10.
- Ma RH, Tsai CC, Shieh TY. Increased lysyl oxidase activity in fibroblasts cultured from oral submucous fibrosis associated

1055

- with betel nut chewing in Taiwan. *J Oral Pathol Med* 1995;24:407-12.
30. Trivedy C, Meghji S, Warnakulasuriya KAAS, Johnson NW, Harris M. Copper stimulates human oral fibroblasts in vitro: a role in the pathogenesis of oral submucous fibrosis. *J Oral Pathol Med* 2001;30:465-70.
  31. Rajendran R, Kumari KR, Kumar AS. Liver ultrasound and faecal copper estimation in oral submucous fibrosis. *Ind J Dent Res* 2003;14:13-21.
  32. Haque MF, Meghji S, Khitab U, Harris M. Oral submucous fibrosis patients have altered levels of cytokine production. *J Oral Pathol Med* 2000;29:123-8.
  33. Tsai C-H, Chou MY, Chang YC. The up-regulation of cyclooxygenase-2 expression in human buccal mucosal fibroblasts by arecoline: a possible role of pathogenesis in oral submucous fibrosis. *J Oral Pathol Med* 2003;32:146-53.
  34. Jeng JH, Ho HS, Chan CP, Wang YJ, Hahn LJ, Chang MC. Areca nut extract up-regulates prostaglandin production, cyclooxygenase-2 mRNA and protein expression of human oral keratinocytes. *Carcinogenesis* 2000;21:1365-70.
  35. Feng Y, Ling T. Changes of cytokine by human oral mucosa keratinocytes from oral submucous fibrosis in vitro. *Hua Xi Kou Qiang Yi Xue Za Zhi* 2000;18:23-5.
  36. Haque MF, Harris M, Meghji S, Barrett AW. Immunolocalization of cytokines and growth factors in oral submucous fibrosis. *Cytokine* 1998;10:713-9.
  37. Chiu CJ, Chiang CP, Chang ML. Association between genetic polymorphism of tumour necrosis factor alpha and risk of oral submucous fibrosis, a precancerous condition of oral cancer. *J Dent Res* 2001;80:2055-9.
  38. Vilcek J, Palombella VJ, Henrikson-DeStefano D. Fibroblast growth factor enhancing activity of tumour necrosis factor and its relationship to other polypeptide growth factors. *J Exp Med* 1986;163:632-43.
  39. Liu Chung-Ji, Lee Yann-Jinn, Chang Kuo-Wei, Shih Yi-Ning, Liu Hsin-Fu, Dang Ching-Wen. Polymorphism of the MICA gene and risk for oral submucous fibrosis. *J Oral Pathol Med* 2004;33:1-6.
  40. Shin Yi-Ning, Liu Chung-Ji, Chang Kuo-Wei, Lee Yann-Jinn, Liu Hsin-Fu. Association of CTLA-4 gene polymorphism with oral submucous fibrosis in Taiwan. *J Oral Pathol Med* 2004;33:200-3.
  41. Tsai CC, Ma RH, Shieh TY. Deficiency in collagen and fibronectin phagocytosis by human buccal mucosa fibroblasts in vitro as a possible mechanism for oral submucous fibrosis. *J Oral Pathol Med* 1999;28:59-63.
  42. Shieh DH, Chiang LC, Lee CH, Yang YH, Shieh TY. Effects of arecoline, safrole and nicotine on collagen phagocytosis by human buccal mucosal fibroblasts as a possible mechanism for oral submucous fibrosis in Taiwan. *J Oral Pathol Med* 2004;33:581-7.
  43. Shieh DH, Chiang LC, Shieh TY. Augmented mRNA expression of tissue inhibitor of metalloproteinase-1 in buccal mucosal fibroblasts by arecoline and safrole as a possible pathogenesis for oral submucous fibrosis. *Oral Oncol* 2003;9:728-35.
  44. Chang YC, Yang SF, Tai KW, Chou MY, Hsieh YS. Increased tissue inhibitor metalloproteinase-1 expression and inhibition of gelatinase A activity in buccal mucosal fibroblasts by arecoline as possible mechanisms for oral submucous fibrosis. *Oral Oncol* 2002;38:195-200.
  45. Utsunomiya H, Ohshiro K, Ida H, Tilakaratne WM, Cheng J, Saku T. Extracellular matrix remodeling in oral submucous fibrosis progression: a structural background for oral carcinogenesis due to chewing habits. *Jpn J Oral Biol* 2002;44:167.
  46. Rajalalitha P, Vali S. Molecular pathogenesis of oral submucous fibrosis—collagen metabolic disorder. *J Oral Pathol Med* 2005;34:321-8.
  47. Chiu CJ, Chang ML, Chiang CP, Hahn LJ, Hsieh LL, Chen CJ. Interaction of collagen-related genes and susceptibility to betel quid-induced oral submucous fibrosis. *Cancer Epidemiol Biomarkers Prev* 2002;11:646-53.
  48. Warnakulasuriya S. Clinical and pathological criteria for diagnosis of oral submucous fibrosis. In: Proceedings of the first Asia-Pacific workshop for oral mucosal lesions, Nagoya, Japan, 1992.
  49. Canniff JP, Harvey W, Harris M. Oral sub mucous fibrosis. Its pathogenesis and management. *Br Dent J* 1986;160:429-34.
  50. Chiang CP, Wu HY, Liu BY, Wang JT, Kuo MY. Quantitative analysis of immunocompetent cells oral submucous fibrosis in Taiwan. *Oral Oncol* 2002;36:58-63.
  51. Chiang CP, Hsieh RP, Chen TH, Chang YE, Liu BY, Wang JT, et al. High incidence of autoantibodies in Taiwanese patients with oral submucous fibrosis. *J Oral Pathol Med* 2002;31:402-9.
  52. Balaran P, Pillai MR, Abraham T. Immunology of premalignant and malignant conditions of the oral cavity. Part II. Circulating immune complexes. *J Oral Pathol Med* 1987;16:389-91.
  53. Remani P, Ankathil R, Vijayan KK, Haseena Beevi VM, Rajendran T, Vijayakumar T. Circulating immune complexes as an immunological marker in premalignant and malignant lesions of the oral cavity. *Cancer Lett* 1988;40:185-91.
  54. Shah N, Kumar R, Shah MK. Immunological studies in oral submucous fibrosis. *Indian J Dent Res* 1994;5:81-7.
  55. Gupta DS, Gupta M, Oswal RH. Estimation of major immunoglobulin profile in oral submucous fibrosis by radial immunodiffusion. *Int J Oral Surg* 1985;14:533-7.
  56. Canniff JP, Batchelor JR, Dodi K, Harvey W. HLA typing in oral submucous fibrosis. *Tissue Antigen* 1985;26:138-42.
  57. Saeed B, Haque MF, Meghji S, Harris M. HLA typing in oral submucous fibrosis. *J Dent Res* 1997;76:1024. (abstract).
  58. Chen HM, Hsieh RP, Yang H, Kuo YS, Kuo MYP, Chiang CP. HLA typing in Taiwanese patients with oral submucous fibrosis. *J Oral Pathol Med* 2004;33:191-9.
  59. Liu CJ, Chu CC, Lee YJ, Shi YN, Lin M. Identification of two novel HLA DRB1 alleles, DRB1-0903 and DRB1-1145. *Tissue Antigens* 2004;64:99-101.
  60. Van Wyk CW, Grobler-Rabie AF, Martel RW, Hammond MG. HLA antigens in oral submucous fibrosis. *J Oral Pathol Med* 1994;23:23-7.
  61. Paymaster JC. Cancer of the buccal mucosa; A clinical study of 650 patients. *Cancer* 1956;9:431-5.
  62. Pindborg JJ, Murti PR, Bhonsle RB, Gupta PC, Daftary DK, Mehta F. Oral submucous fibrosis as a precancerous condition. *Scand J Dent Res* 1984;92:224-9.
  63. Pindborg JJ, Satyawati M, Sirsat M. Oral submucous fibrosis. *Oral Surg Oral Med Oral Pathol* 1966;22:774-9.
  64. Warnakulasuriya S. Histological grading of oral epithelial dysplasia: revisited. *J Pathol* 2001;194:294-7.
  65. Pindborg JJ, Poulsen E, Zachariah J. Oral epithelial changes in thirty Indians with oral cancer and oral submucous fibrosis. *Cancer* 1967;20:1141-6.
  66. Murti PR, Bhonsle RB, Pindborg JJ, Daftary DK, Gupta PC, Mehta FS. Malignant transformation rates in oral submucous fibrosis over a 17 year period. *Community Dent Oral Epidemiol* 1985;13:340-1.
  67. Lee CH, Ko YC, Huang HL, Chao YY, Sheih TY, Lin LM. The precancer risk of betel chewing, tobacco use and alcohol consumption in oral leukoplakia and oral submucous fibrosis in Southern Taiwan. *Br J Cancer* 2003;88:366-72.
  68. Warnakulasuriya S, Trivedy C, Peters TJ. Areca nut use: an independent risk factor for oral cancer. *Br Med J* 2002;321:799-800.

1056  
2

69. Jeng JH, Chang MC, Hahn LJ. Role of areca nut in betel quid associated chemical carcinogenesis: current awareness and future perspectives. *Oral Oncol* 2001;37:477-92.
70. Warnakulasuriya KAAS, Trivedy C, Maher R, Johnson NW. Aetiology of oral submucous fibrosis. *Oral Dis* 1997;3:286-7.
71. Johnson NW, Ranasinghe AW, Warnakulasuriya KAAS. Potentially malignant lesions and conditions of the mouth and oropharynx: natural history—cellular and molecular markers of risk. *Eur J Cancer Prevent* 1993;2(Suppl 2):31-51.

1957  
A

## Betel quid not containing tobacco and oral leukoplakia: A report on a cross-sectional study in Papua New Guinea and a meta-analysis of current evidence

Steven J. Thomas<sup>1\*</sup>, Ross Harris<sup>2</sup>, Andrew R. Ness<sup>3</sup>, Joachim Taulo<sup>4</sup>, Robert MacLennan<sup>5</sup>, Noah Howes<sup>6</sup> and Christopher J. Bain<sup>7</sup>

<sup>1</sup>Division of Maxillofacial Surgery, University of Bristol, Bristol, United Kingdom

<sup>2</sup>Department of Social Medicine, University of Bristol, Bristol, United Kingdom

<sup>3</sup>Department of Oral and Dental Science, University of Bristol, Bristol, United Kingdom

<sup>4</sup>Department of Health, Kavieng, New Ireland, Papua New Guinea

<sup>5</sup>Population and Clinical Sciences, Queensland Institute of Medical Research, Brisbane, Australia

<sup>6</sup>University Hospital of Wales, Cardiff, United Kingdom

<sup>7</sup>School of Population Health, University of Queensland, Brisbane, Australia

Leukoplakia is an asymptomatic, potentially malignant change in the oral mucosa. Previous studies have reported that smoking and betel quid chewing are associated with increased risk of leukoplakia; few studies have reported on these associations in populations where betel quid does not contain tobacco. We conducted a case-control study nested in a cross-sectional study in Papua New Guinea and a systematic review of studies that included chewers of betel quid without tobacco. Our study recruited 1,670 adults. We recorded betel quid chewing and smoking. The prevalence of leukoplakia was 11.7%. In the nested case-control study of 197 cases and 1,282 controls, current betel chewing was associated with increased risk of leukoplakia with an adjusted odds ratio for current chewers of 3.8 (95% CI 1.7, 8.4) and in the heaviest chewers of 4.1 (95% CI 1.8, 9.1) compared to non-chewers. Current smoking was associated with an increased risk of leukoplakia with an adjusted odds ratio for current smokers of 6.4 (95% CI 4.1, 9.9) and amongst heaviest smokers of 9.8 (95% CI 5.9, 16.4) compared to non-smokers. The systematic review identified 5 studies examining risk of leukoplakia associated with betel quid chewing in populations where betel quid did not contain tobacco and that controlled for smoking. In studies that adjusted for smoking, the combined random effect odds ratio was 7.9 (95% CI 4.3, 14.6) in betel quid chewers. The results of this study and systematic review of similar studies provide evidence of the role of betel quid not containing tobacco and leukoplakia.

© 2008 Wiley-Liss, Inc.

**Key words:** betel quid; smoking; oral leukoplakia; oral cancer; Papua New Guinea

Melanesia has the highest incidence of oral cancer in the world<sup>1</sup> and it is the most common cancer in Papua New Guinea (PNG). Rates are also high in South Asia.<sup>1</sup> In these populations, oral cancer is related to smoking and betel quid use. We recently reported a case-control study and a systematic review of betel quid without tobacco and found an increased risk of oral cancer independent of smoking.<sup>2</sup> We report here studies of betel quid without tobacco and risk of oral leukoplakia.

Oral leukoplakia is an asymptomatic, potentially precancerous lesion. In a 10-year follow-up study in India, oral leukoplakia preceded oral cancer in nearly 70% of cancer cases.<sup>3</sup> The association of risk factors with oral leukoplakia can offer insights into the causal pathway. Furthermore, investigations into the aetiology of oral leukoplakia may be less biased than cancer studies, as leukoplakia is asymptomatic and therefore unlikely to modify behaviour although recall of behaviour might be more related to time. Studies of oral leukoplakia show similar results for smoking and betel quid (that contains tobacco) to those of oral cancer in India<sup>4</sup>; however, until recently there have been few studies of betel quid without tobacco and oral leukoplakia. We present here data from a previously unpublished study in PNG (where betel quid is tobacco free) and other recently published research

identified in a systematic review and meta-analysis. We summarise the current state of the literature for the first time.

### Material and methods

In PNG, oral cancer is predominantly a disease of lowland and coastal regions and is most common in New Ireland Province, an island with a Melanesian population. A sample of persons aged 18 years or more was selected from 2 census districts of New Ireland Province with the highest incidence of oral cancer. In March 1992, each person in the sample had a mouth examination, and information on exposures was collected using an interviewer-administered questionnaire. The Papua New Guinea Medical Research Committee approved the project. Village leaders in each of the participating villages were visited before the study began, and the implication of participation was explained to the village elders and then to the village as a whole. Following this general consent to enter the village, individual verbal consent was sought.

### Study population

The prevalence of leukoplakia was investigated in East Coast Kara Nalik census division (Kavieng District; annual average incidence (AAI) of oral cancer 91.4 per 10<sup>5</sup>) and South Lavongai census division (Lamet District AAI of oral cancer 93.4 per 10<sup>5</sup>). For each study area (census division), a random sample of all census units was selected from a list of all census units using a computerised randomisation procedure to provide a study population of 1,000 from each census division. All people over the age of 18 years within each village were eligible to be examined. The census clerk and village elders defined those normally resident, up-dating the contemporary electoral roll. Eligible villagers were enumerated according to the study census and examined and interviewed as described later.

### The interview

All subjects were interviewed by investigators fluent in Melanesian Pidgin and Tok ples (local language), trained in a standard manner using a detailed instruction manual and monitored using tape recordings of the interviews. Interviews were conducted in Melanesian Pidgin and out of hearing distance of other villagers.

Grant sponsors: Queensland Cancer Fund, Australia, The National Health and Medical Research Council of Australia, The Royal College of Surgeons of England, The Papua New Guinea Institute of Medical Research, Department of Health Papua New Guinea.

\*Correspondence to: University of Bristol, Lower Maudlin Street, Bristol BS1 2LY, UK. E-mail: steve.thomas@bristol.ac.uk

Received 19 November 2007; Accepted after revision 22 April 2008  
DOI 10.1002/ijc.23739

Published online 7 August 2008 in Wiley InterScience (www.interscience.wiley.com)



1958

The interviewer was blinded to the presence of oral lesions in the subject at the time of interview. The timing of key events, such as the Second World War, was used to estimate age of the participants. To obtain frequency data on smoking and betel quid chewing, each person was first asked about their regular daily activities from waking until going to sleep (divided into morning, afternoon and night). The interviewee was asked to estimate how many areca nuts had been chewed and how many "cigarettes" (flue cured tobacco) or *stiks of tabac* or *brus leaves* (air dried tobacco) had been smoked during each period. Details of preparation and use of betel quid and tobaccos were recorded.

#### Exposure data

Age was estimated within 5-year age groups, with those aged above 60 years placed into a single category, and gender was recorded. The reference groups for all analyses were currently the unexposed non-smokers or non-chewers. This included never users, as well as former smokers or chewers who had stopped for 1 year or more prior to the interview. Current smokers or chewers were either occasional or daily users; occasional smokers or chewers smoked or chewed at least every week but not daily. Current users of either tobacco or betel quid were split into 3 categories according to the frequency of use grouped into thirds, based on the joint distribution of cases and controls. For daily smoking, the estimate was based on cigarette equivalents. Commercial (*stik*) and home-grown (*brus*) air-cured tobaccos were rolled in newspaper to form a cigarette ~15 cm long. If a pipe or leaf cigar was used, half a leaf of *brus* was equivalent to 1 standard newspaper cigarette (based on the assessment of New Ireland *brus* leaf tobacco smokers). One newspaper cigarette was equivalent to three commercial flue-cured cigarette equivalents. Usual frequency of smoking and chewing were also estimated in Melanesian Tok Pisin by the interviewee on a scale of low (*wanwan*), medium (*sampela*) and high (*planti*).

#### Case definition and examination

Oral leukoplakia is defined as a white patch or plaque that cannot be characterised clinically or pathologically as any other disease.<sup>5</sup> This clinical definition is useful where routine biopsy is unavailable. All oral leukoplakia were photographed and colour slides of the lesions classified as leukoplakia were reviewed independently by an oral pathologist who agreed with the original clinical diagnosis in every case. Each participant was examined under natural light (by ST) after being interviewed by another member of the study team. Oral cancer was defined clinically on the basis of appearance; commissural ulcers were defined as erosive lesions occurring at the labial commissure. The remaining lesions were oral leukoedema (a greyish or white area with indistinct borders) and oral erythroplakia (a red velvety plaque which cannot be defined clinically or pathologically as any other condition).

#### Nested case-control study

Cases and controls were a subset of the population ascertained from the cross-sectional study. Cases were people with leukoplakia defined as earlier. Controls were all people who were ascertained in the cross-sectional study with no evidence of oral squamous cell carcinoma, leukoplakia, leukoedema, erythroplakia or commissural ulceration.

#### Statistical methods

Unconditional multiple logistic regression was used to estimate odds ratios (ORs), and 95% confidence intervals (CIs) for the association between smoking and betel quid chewing, and to adjust for the effects of the confounding effects of age, sex and area of residence. Unadjusted ORs, and ORs adjusted for age, sex, area of residence and either smoking or betel chewing were estimated.

#### Systematic review and meta-analysis

Studies were located by searching MEDLINE (from inception to January 2006), and the reference lists of relevant texts and

reviews. A hierarchical literature search in MEDLINE used the following National Library of Medicine MeSH terms (Medical Subject Headings): "Oral Neoplasms," "Mouth," "Betel," "Areca" the additional keywords oral, oropharynx and leukoplakia, cancer, and carcinoma were also used in MEDLINE (truncated where necessary). Eligible studies were case-control studies of oral leukoplakia that had documented exposure to betel quid in populations where betel quid did not contain tobacco (no relevant cohort studies have been reported). To identify potentially eligible studies, the title and abstract of each study identified by the literature search was assessed. Full papers of potentially relevant studies were reviewed. Data extracted included numbers of cases and controls who were and were not exposed to betel quid without tobacco, evidence for a dose response with betel quid chewing without tobacco, exposure to tobacco smoke, adjustment for tobacco smoking in the analysis, year of publication, country and sample size. Some papers reported their results in a form suboptimal for meta-analysis; to utilise these fully we used procedures and assumptions described in the technical appendix.

We used inverse-variance weighted fixed-effect meta-analysis and DerSimonian and Laird random-effects meta-analyses<sup>6</sup> to derive summary ORs in non-smokers who chewed betel quid and for betel quid chewing after adjustment for smoking. Between-study heterogeneity was assessed using  $I^2$  statistics Stata version 8.2 was used for all analyses.

#### Results

Seventy-four percent of eligible participants were enrolled in the study. The age and sex distribution of the sample was similar to the adult age and sex distribution of the province as a whole. The age distribution in the sample was 62.6% for males and 72.5% for females 18–45 years (compared with 64.7 and 65.6%, respectively, for the 1980 census of New Ireland) and 37.4% for males and 27.5% for females 46 years and above (compared with 35.3 and 34.4%, respectively, for the 1980 census of New Ireland). Oral leukoplakia was present in 197 out of 1,678 people examined (11.7%). In almost all cases (94%), the commissure and/or the buccal mucosa were affected (data is not shown in tables). The male to female ratio for leukoplakia was 4 to 1, with a prevalence among men of 19.5% and among women of 4.7% ( $p < 0.001$ ). The prevalence of leukoplakia was higher in older age groups ( $p < 0.001$ , Table I).

A further 199 people had oral mucosal abnormalities other than leukoplakia and are not included in the case-control analysis; these abnormalities included preleukoplakia, commissural ulcers, erythroplakia and oral cancer. No oral mucosal abnormalities were identified in the other 1,282 people studied, who consequently formed the control group.

Around half of the people in the case-control study (49%) had smoked tobacco (91% of cases and 43% of controls) and nearly everyone had chewed betel quid (99% of cases and 93% of controls). Overall, 38% of people were current smokers (84% of cases and 30% of controls) and 83% were current betel quid chewers (96% of cases and 82% of controls).

Betel quids in this population did not contain tobacco and were unwrapped. The constituent areca nut, slaked lime powder and the inflorescence of the piper betle plant (the flower stalk of the plant) were placed separately in the mouth. The nut was chewed first, and then powdered slaked lime was added repeatedly. Most people used a piper betle inflorescence, which was also chewed, to add the lime, whereas others added lime using a wooden spatula. If a stick or spatula was used, the inflorescence or leaf of the piper betle was still chewed. The quid was usually chewed for about 15 min, which was intensely sialogenic and turned bright red. The risks of oral leukoplakia associated with betel quid chewing are summarised in Table II. Risk of oral leukoplakia was substantially elevated in current daily betel quid

1059

TABLE I - PREVALENCE PER 100 OF LEUKOPLAKIA ACCORDING TO GENDER, AGE AND CENSUS DIVISION

Factor	Cases	Denominator	Prevalence	95% CI	p-value for $\chi^2$
Male	156	799	19.5	16.9, 22.4	<0.001
Female	41	879	4.7	3.4, 6.2	
Age					<0.001
18-29	26	656	3.1	2.6, 5.6	
30-39	43	350	10.9	9.1, 16.0	
40-49	34	178	16.3	13.8, 25.3	
50-59	43	195	20.0	16.6, 28.2	
60+	51	299	14.7	13.1, 21.6	
Census division					0.907
East Coast Kara Nalik	111	952	11.7	9.7, 13.8	
South Lavongai	86	726	11.8	9.6, 14.3	
Total	197	1678	11.7	10.3, 13.3	

TABLE II - RISK FACTORS FOR ORAL LEUKOPLAKIA, CRUDE AND ADJUSTED FOR AGE SEX AND CENSUS

	Case	Control	ORs <sup>1</sup>	95% CI	ORs <sup>2</sup>	95% CI
<b>Chewing</b>						
Never	1	89	1.0	Referent	1.0	Referent
Ex-chewer	7	149	4.2	0.5, 34.6	1.4	0.2, 13.0
Occasional	26	256	9.0	1.2, 67.6	6.1	0.8, 48.7
Daily	163	788	18.4	2.5, 133.1	5.0	0.6, 39.1
Non-chewer <sup>3</sup>	8	238	1.0	Referent	1.0	Referent
Current Chewer	189	1044	5.4	2.6, 11.8	3.8	1.7, 8.4
Non-chewer <sup>3</sup>	8	238	1.0	Referent	1.0	Referent
Low ( $\leq 2$ daily)	38	346	3.3	1.5, 7.1	4.3	1.9, 10.0
Medium (3-8 daily)	60	343	5.2	2.4, 11.1	4.0	1.8, 9.1
High ( $\geq 9$ daily)	91	355	7.6	3.6, 16.0	4.1	1.8, 9.3
Low (Wanwan)	32	266	3.6	1.6, 7.2	4.7	2.0, 11.1
Medium (Sampela)	77	432	5.3	2.5, 11.2	4.8	2.1, 10.8
High (Planti)	80	346	6.9	3.3, 16.0	4.0	1.8, 9.1
<b>Smoking</b>						
Never	17	732	1.0	Referent	1.0	Referent
Ex-smoker	14	161	3.7	1.8, 7.8	1.7	0.8, 3.8
Occasional	24	105	9.8	5.1, 18.9	6.5	2.6, 10.7
Daily	142	284	21.5	12.8, 36.3	9.1	4.8, 15.7
Non-smoker <sup>3</sup>	31	893	1.0	Referent	1.0	Referent
Current Smoker	166	389	12.3	8.2, 18.4	6.4	4.1, 9.9
Non-smoker <sup>3</sup>	31	893	1.0	Referent	1.0	Referent
Low ( $\leq 5$ daily)	31	140	6.4	3.8, 12.3	4.7	2.7, 8.2
Med (6-11 daily)	54	127	12.3	7.6, 18.6	6.6	3.9, 11.1
High ( $\geq 12$ daily)	81	122	19.1	12.1, 30.2	9.8	5.9, 16.4
Low (Wanwan)	52	175	8.8	5.3, 14.6	5.0	3.0, 8.4
Medium (Sampela)	65	150	11.6	8.4, 25.5	6.7	4.0, 11.1
High (Planti)	49	64	22.0	12.8, 37.9	10.2	5.7, 18.4

<sup>1</sup>Crude odds ratios and 95% confidence intervals.—<sup>2</sup>Adjusted odds ratios and 95% confidence intervals adjusted for age, sex, census division and betel quid chewing or smoking.—<sup>3</sup>Non-chewer includes never or ex-smokers.

TABLE III - ODDS RATIOS FOR LEUKOPLAKIA ACCORDING TO BETEL CHEWING AND SMOKING AMONG CURRENT CHEWERS AND SMOKERS

Current smoking		Current betel chewing	
		No <sup>1</sup>	Yes
No <sup>1</sup>	OR	1.0 <sup>2</sup>	3.9
	95% CI	-	1.3, 11.5
Yes	Cases, controls	4, 219	27, 674
	OR <sup>3</sup>	6.6	24.3
	95% CI	(1.5, 29.3)	(8.7, 67.4)
	Cases, controls	4, 19	162, 370

<sup>1</sup>Non-chewer includes never or ex-chewers and non-smoker includes never or ex-smokers.—<sup>2</sup>Referent category.—<sup>3</sup>ORs adjusted for age, sex and census division.

chewers, although after adjustment for confounding effects of smoking, gender, age and census division there was no suggestion of a linear dose response.

Various types of tobacco were smoked. Locally and commercially grown air-dried "Black" tobacco (*brus* or *stik*) was most

common (89%), whereas commercial flue-cured machine rolled "Blond" tobacco cigarettes were occasionally smoked (5%). Only *brus* varied in the way it was smoked, either wrapped in newspaper or tobacco leaf, or, less frequently, smoked in a pipe (data not shown in tables). The risk of oral leukoplakia associated with smoking are summarised in Table II, with elevations seen across all categories of smoking exposure. Relative to non-smokers, the risk was highest in current smokers with a strong dose-response relationship for both current daily tobacco consumption and for qualitative estimates of usual consumption (low, medium and high) ( $p_{trend}$  for both <0.001). Despite some attenuation, clinically important associations remained after adjustment for gender, age, census division and betel quid chewing.

The separate and joint effects of smoking and betel quid chewing on the risk of oral leukoplakia are compared in Table III. Rather strong independent relations were seen in smokers who did not chew (OR = 6.6) and in betel chewers who did not smoke (OR = 3.9); and joint exposure produced a remarkable OR of 24.3 (95% CI 8.7, 67.4) compared to people who did neither.

1060  
2

TABLE IV - CASE-CONTROL STUDIES ASSESSING RISK OF ORAL LEUKOPLAKIA AMONG CHEWERS OF BETEL QUID WITHOUT TOBACCO. CHARACTERISTICS AND ODDS RATIOS (OR) IN STUDIES OF NON-SMOKERS AND THOSE ADJUSTED FOR SMOKING

Smoking status, Year, Country	Author	Controls	Number of cases (% chewers)	Number of controls (% chewers)	Betel quid Chewing	Adjusted	OR	95% CI
<b>Non-smokers</b>								
2003, Taiwan	Lee	Pop	19 (37)	258 (9)	Yes/never	Yes <sup>1</sup>	10.0	3.1, 32.5
2004, India	Jacob	Pop	17 (49)	26,931 (3)	Yes/no chewer	Yes <sup>2</sup>	22.2	11.3, 43.7
2005, Taiwan	Chung	Pop	24 (4)	738 (0.4)	Yes/no habits	Yes <sup>3</sup>	8.6	0.8, 88.1
2007, PNG	Thomas	Pop	31 (87)	893 (76)	Yes/non-chewers	Yes <sup>4</sup>	3.9	1.3, 11.5
<b>Adjusted for smoking</b>								
2000, Taiwan	Shiu	Hsp	102 (70)	195 (22)	Yes/never	Yes <sup>5</sup>	17.4	1.9, 156.4
2003, Taiwan	Lee	Pop	40 (83)	160 (24)	Yes/never	Yes <sup>6</sup>	16.1	9.8, 26.5
2004, India	Jacob	Pop	32 (13)	152 (8)	Yes/no chewer	Yes <sup>7</sup>	4.0	2.7, 6.1
2006, Taiwan	Chen	Hsp	79 (53)	149 (11)	Ever/never	Yes <sup>8</sup>	22.8	3.6, 146.1
2007, PNG	Thomas	Pop	197 (96)	1,282 (81)	Yes/non-chewers	Yes <sup>9</sup>	3.8	1.7, 8.4

<sup>1</sup>Adjusted for education occupation and alcohol drinking. <sup>2</sup>Adjusted for age, sex, education and BMI (kg/m<sup>2</sup>) in non drinkers of alcohol. <sup>3</sup>Adjusted for age, sex, in non-smokers and non-drinkers of alcohol. <sup>4</sup>Adjusted for age, sex and census division. <sup>5</sup>Adjusted for alcohol and smoking, matched for age ( $\pm 3$  years), sex, date of diagnosis ( $\pm 3$  months). <sup>6</sup>Adjusted for education, occupation, cigarette smoking, in non-alcohol drinkers, matched for age ( $\pm 3$  years) and gender. <sup>7</sup>Adjusted for age, sex, education, BMI (kg/m<sup>2</sup>) pack years smoking and years of alcohol. <sup>8</sup>Adjusted for age, smoking and Human Papilloma Virus. <sup>9</sup>Adjusted for age sex, census division and smoking.

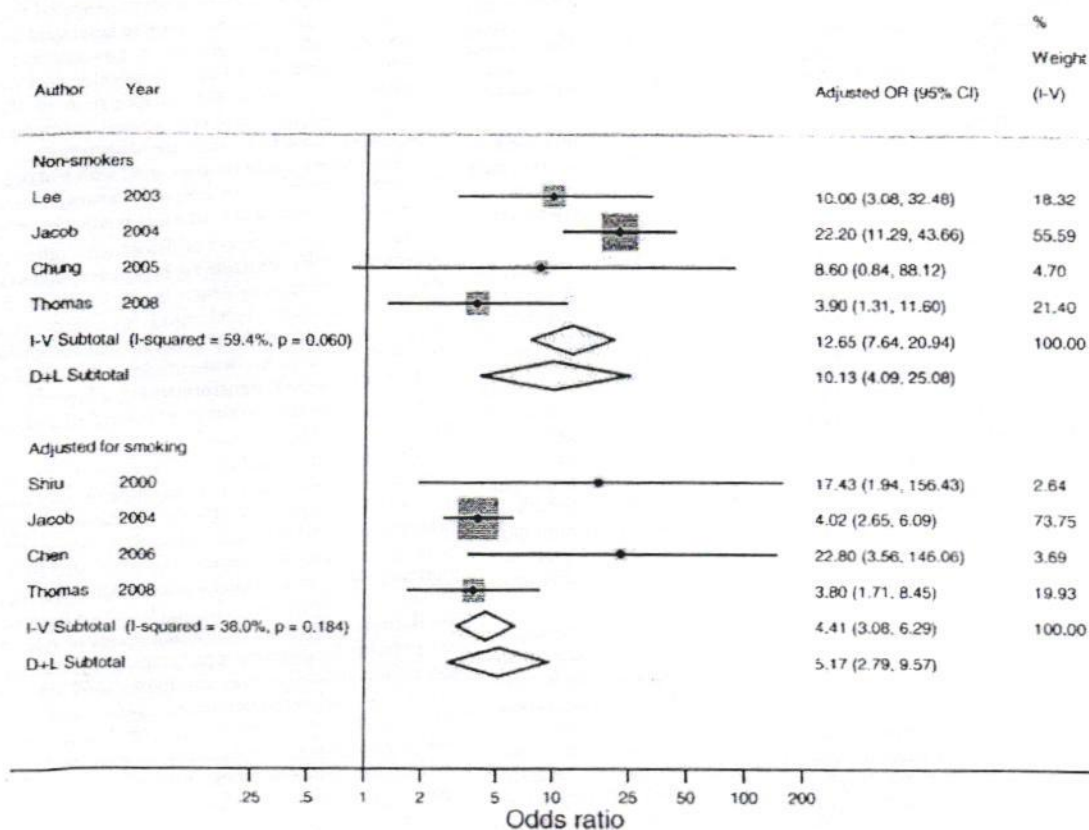

FIGURE 1 - Forest plot of the risk of oral leukoplakia among non-smokers and where data are adjusted for smoking.

#### Systematic review and meta-analysis

We identified 6 case-control studies that examined risk of oral leukoplakia associated with chewing betel quid in populations where betel quid did not contain tobacco.<sup>7-12</sup> One of these did not report on non-smokers and did not adjust for tobacco smoking in the analysis (adjusted estimates were presented only for leukoplakia and submucous fibrosis combined).<sup>12</sup> However, this study<sup>12</sup> did report unadjusted dose response data. The 5 remaining studies<sup>7-11</sup> were included in the review together with the results of our study.

Table IV shows characteristics of the studies including the numbers of cases and controls and the proportion exposed to betel quid that did not contain tobacco. Four were population-based and two were hospital-based case-control studies of leukoplakia. All 6 reported dichotomous chewing outcomes (3 never vs. ever, 2 yes vs. no, and 1 non vs. current); 4, including our study, reported a dose-response related to daily chewing frequency.

Among non-smokers, the proportion of oral leukoplakia cases with current exposure to betel quid without tobacco ranged from 4 to 87%, with control proportions from 0.4 to 76%. Four studies,

10961  
L

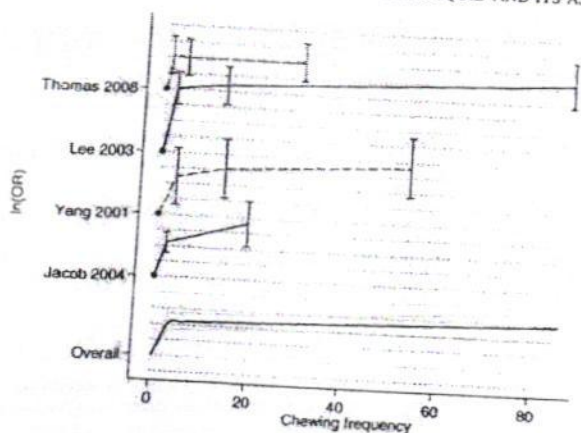

FIGURE 2 - Dose-response plot of betel quid chewing frequency. (Log) odds ratios (ln (OR)) and confidence intervals are plotted against estimated mean group exposure level. ORs relate to the unexposed group or the lowest level of exposure in the Yang study, and the reference lines correspond to a doubling of risk. [Color figure can be viewed in the online issue, which is available at [www.interscience.wiley.com](http://www.interscience.wiley.com).]

including the present one, reported on betel quid without tobacco chewing in non-smokers, with varying control for other potential confounding factors.<sup>7-9</sup> Four studies including the present one reported effect estimates adjusted for smoking together with other potential confounders.<sup>8,10,11</sup>

Meta-analysis stratified according to the method of control for tobacco smoking (by restriction to non-smokers or by adjustment for smoking status) (Table IV, Fig. 1) shows a clear pattern of increased risk of oral leukoplakia when exposed to betel quid without tobacco when the person was not a current smoker (fixed effect summary OR 12.7, 95% CI 7.6, 20.9 and random-effects summary OR 10.1, 95% CI 4.1, 25.1). There was evidence of between-study heterogeneity in these effects ( $I^2 = 59.4\%$ ,  $p = 0.060$ ), but the qualitative impression is compelling. The risk of oral leukoplakia was also increased among chewers of betel quid without tobacco after adjusting for tobacco smoking (fixed effect summary OR 6.8, 95% CI 5.1, 9.1 and random-effects summary OR 8.2, 95% CI 3.5, 19.2), again showing a consistent pattern despite evidence of between-study heterogeneity ( $I^2 = 81.9\%$ ,  $p < 0.001$ ).

The 4 studies (including the present one)<sup>7,8,12</sup> that presented a dose-response for daily frequency of chewing demonstrated an increased risk with exposure to betel quid after adjusting for the effect of smoking. The fitted dose-response relationship varied greatly depending on the choice of model and, therefore, the results should be interpreted with some caution. However, in all models the general shape of the relationship appeared to indicate an increase in risk at low levels of exposure, which levelled off at higher exposure levels (Fig. 2) (for more details see technical appendix). In addition, 1 study<sup>10</sup> reported chewing intensity (the product of duration and daily frequency) and showed a dose response.

### Discussion

We have attempted to clarify the association between betel quid (not containing tobacco) and oral leukoplakia using previously unpublished data from a population where this association has not been described and by systematic review and formal synthesis of the results from this and other studies. All reports on this exposure are recent, and no formal systematic review or meta-analysis exists. We found increased risk of oral leukoplakia independent of smoking with a suggestion of dose response (but with lower increase in risk at higher doses). We also confirmed the independent and important effect of smoking as risk factor, and the

extremely strong relation between being exposed to both tobacco smoke and betel quid and having leukoplakia.

In PNG, betel quid chewing is common and it is challenging to get accurate exposure data. Despite misclassification and the small number who did not chew betel quid, the lower limit of the CI was not close to the null value and even the lower bound was consistent with an important increase in risk. The dose-responses observed for smoking and betel quid chewing were present when using daily frequency estimated numerically and also when the interviewee estimated their usual consumption as "Wanwan," "Samplea" and "Planti."

Bias is a possible explanation for the observed associations. However, we had good recruitment with 74% of the eligible population taking part, and the study population had similar demographics to the overall population of New Ireland province. We assessed exposures before the clinical examination and as the lesions were asymptomatic it is unlikely to have affected recall or behaviour. Known confounders, (age, sex and smoking) were adjusted; and though adjustment attenuated the risk of oral leukoplakia associated with exposure to betel quid a clinically important association remained present in non-smokers. Even though confounding by unknown factors is possible, this would have had to be substantial to change the interpretation of the current findings. Reverse causality is unlikely as oral leukoplakia is asymptomatic and most people were unaware of its presence. The recruitment of prevalent cases could be associated with leukoplakia that is chronic and does not resolve or progress; however, previous studies have shown that leukoplakia is strongly predictive of oral cancer.

Our findings are also consistent with other geographical comparisons in PNG. Existing reports of leukoplakia in PNG<sup>13,14</sup> both indicate a higher prevalence in the lowlands than the highlands, where historically betel quid was less commonly chewed. Although neither of these geographical comparisons directly estimated the association with smoking and betel quid chewing (or looked at malignant transformation), a higher prevalence of leukoplakia was observed in those who smoked and chewed betel, with up to 25% of males affected.

We have extended previous reviews by presenting previously unpublished data and combining this in a systematic review and meta-analysis. Only six studies (including the present one) have examined the risk of oral leukoplakia in populations where betel quid does not contain tobacco and accounted for the potential confounding effect of smoking tobacco. Although there was statistical evidence of heterogeneity (possibly in part because of the different populations studied with different levels of risk, different designs and potentially different confounding structures), making effect size estimates less secure, all studies were consistent in showing excess risk, and estimates using random and fixed effect models were similar. The summary estimates based on the dose-response estimates suggest a threshold effect with the initial increased risk plateauing with increased exposure.

Betel quids in this population did not contain tobacco and were unwrapped. Previous studies have shown that lime when placed in the mouth causes the mean pH to rise to 10, at which point reactive oxygen species are generated from the areca nut *in vitro*.<sup>15</sup> The lime has also been shown to cause ulceration of the oral mucosa. These reactive oxygen species, together with sustained lime-induced cell proliferation following the ulceration, provide a possible mechanism for the development of leukoplakia that may then progress to oral carcinoma. Oral leukoplakia is considered a pre-cancerous lesion—so the increased risk with betel quid strengthens the evidence that betel quid plays an important and causal role in oral carcinogenesis. In addition to providing mechanistic insights, studies of leukoplakia provide an important confirmation of associations observed with oral cancer as they are less likely to be biased by change in behaviour or recall associated with symptomatic disease.

Our study thus adds to the literature as we have confirmed the importance of smoking as a dose-related risk factor for oral leuko-

1062  
R

plakia. Therefore, even in populations where betel quid use is common there is a need for effective smoking prevention and cessation programmes. We have also shown that betel quid chewing is associated in a dose-related manner with increased risk of oral leukoplakia in populations where the betel quid does not contain tobacco. We have previously reported that the type and use of slaked lime may modify the risk of oral cancer associated with betel quid chewing. Modifications to the composition of betel quid could be an effective means of reducing the risk of oral cancer, but further studies are required.

As betel quid in many countries contains tobacco and the chewing of betel quid is often associated with smoking, few studies have been able to estimate the role of betel quid as an independent risk factor for oral leukoplakia or oral cancer reliably. It is clearly desirable to establish the extent to which risk factors for leukoplakia and frequency of malignant transformation are consistent across societies. A prospective study of this cohort is ongoing to describe the association of smoking and betel quid with incidence of leukoplakia and oral cancer in this high risk population.

## References

- Parkin DM. International variation. *Oncogene* 2004;23:6329-40.
- Thomas SJ, Bain CJ, Bastistutta D, Ness AR, Paissat D, MacLennan R. Betel quid not containing tobacco and oral cancer; a report on a case-control study in Papua New Guinea and a meta-analysis of current evidence. *Int J Cancer* 2007;120:1318-23.
- Gupta PC, Mehta FS, Pindborg JJ, Bhonsle RB, Murti PR, Daftary DK, Aghi MB. Primary prevention trial of oral cancer in India: a 10 year follow up study. *J Oral Pathol Med* 1992;21:433-9.
- Gupta PC. A study of dose response relationship between tobacco habits and oral leukoplakia. *Br J Cancer* 1984;50:527-31.
- Axell T, Holmstrup P, Kramer IHR, Pindborg JJ, Shear M. International seminar on oral leukoplakia and associated lesions related to tobacco habits. *Community Dent Oral Epidemiol* 1984;12:145-54.
- DerSimonian R, Laird N. Meta-analysis in clinical trials. *Control Clin Trials* 1986;7:177-88.
- Lee CH, Ko YC, Huang HL, Chao YY, Tsai CC, Shieh TY, Lin LM. The precancer risk of betel quid chewing, tobacco use and alcohol consumption in oral leukoplakia and oral submucous fibrosis in southern Taiwan. *Br J Cancer* 2003;88:366-72.
- Jacob BJ, Straif K, Thomas G, Ramadas K, Mathew B, Zhang ZF, Sankaranarayanan R, Hashibe M. Betel quid without tobacco as a risk factor for oral precancers. *Oral Oncol* 2004;40:697-704.
- Chung CH, Yang YH, Wang TY, Shieh TY, Warnakulasuriya S. Oral precancerous disorders associated with areca quid chewing, smoking, and alcohol drinking in southern Taiwan. *J Oral Pathol Med* 2005;34:460-6.
- Shiu MN, Chen TH, Chang SH, Hahn LJ. Risk factors for leukoplakia and malignant transformation to oral carcinoma: a leukoplakia cohort in Taiwan. *Br J Cancer* 2000;82:1871-4.
- Chen PC, Pan CC, Kuo C, Lin CP. Risk of oral nonmalignant lesions associated with human papillomavirus infection, betel quid chewing, and cigarette smoking in Taiwan: an integrated molecular and epidemiologic study. *Arch Pathol Lab Med* 2006;130:57-61.
- Yang YH, Lee HY, Tung S, Shieh TY. Epidemiological survey of oral submucous fibrosis and leukoplakia in aborigines of Taiwan. *J Oral Pathol Med* 2001;30:213-19.
- Atkinson L, Chester IC, Smythe FG, Ten Seldam RE. Oral cancer in New Guinea: a study in demography and etiology. *Cancer* 1964;17:1289-98.
- Pindborg JJ, Barmes D, Roed-Peterson. Epidemiology and histology of oral leukoplakia and leukoedema among Papuans and New Guineans. *Cancer* 1968;22:379-84.
- Thomas SJ, MacLennan R. Slaked lime and betel nut cancer in Papua New Guinea. *Lancet* 1992;340:577-8.
- Greenland S, Longnecker MP. Methods for trend estimation from summarized dose-response data, with applications to meta-analysis. *Am J Epidemiol* 1992;135:1301-9.
- Chêne G, Thompson SG. Methods for summarizing the risk associations of quantitative variables in epidemiologic studies in a consistent form. *Am J Epidemiol* 1996;144:610-21.
- Remmenga MD, Milliken GA, Kratzer D, Schwenke JR, Rolka HR. Estimating the maximum effective dose in a quantitative dose-response experiment. *J Anim Sci* 1997;75:2174-83.

## Appendix

To estimate the main effect of betel chewing from the  $2 \times 2$  table presented by Lee<sup>7</sup> for chewing betel quid without tobacco and alcohol consumption adjusted for smoking tobacco, we used an iterative method to fit cell counts to the interior of the total data table such that  $(a_j/b_j)/(a_0/b_0) = OR_j$  for each group  $j$ , where  $a$  and  $b$  are the cases and non-cases in each group. This technique is used in the method by Greenland and Longnecker for summarising risk associations.<sup>16</sup> With the fitted numbers, we were then able to collapse cells and estimate the appropriate adjusted odds ratio.

Although studies reported dose-response data by categories of exposure level, we calculated the mean exposure level in each group. A log-normal distribution of exposure was assumed, and fitted based on the number of cases and non-cases in each group as proposed by Chêne and Thompson.<sup>17</sup> We then used the method of Greenland and Longnecker<sup>16</sup> to estimate an overall dose-response relationship, adapting the method to incorporate a join-point to allow for a change in slope at different exposure levels. Single linear-linear splines<sup>18</sup> were tested with knots at different points, and the model with the lowest  $\chi^2$  goodness of fit statistic was used. The study by Yang *et al.*<sup>12</sup> did not report ORs for each group; we therefore used those reported in the WHO monograph.<sup>2</sup> We were unable to recreate the ORs based on the raw numbers given by Yang *et al.*<sup>12</sup> and must assume that they had access to more detailed data from this study. The results of the analyses are presented as an un-anchored dose-response plot, with ORs and confidence intervals plotted against the estimated mean group exposure levels.

The estimates of mean exposure level were high in the unbounded upper group, particularly in the study by Lee,<sup>7</sup> due to the assumption of a log-normal distribution. We therefore repeated analyses with the estimate truncated to twice the lower bound of exposure level in the top group. This made little difference to the dose-response plot, aside from an obvious reduction in range of exposure at the top end, and the same plateau effect was observed. The model with the best fit had a knot at the 40th percentile of the exposure distribution, corresponding to a change in the dose-response relationship at a relatively low level of exposure (in our study, this corresponded to non-chewers and all other chewers).

10963

## A population-based case-control investigation on cancers of the oral cavity in Bangalore, India.

A. Nandakumar, K.T. Thimmasetty, N.M. Sreeramareddy, T.C. Venugopal, Rajanna, A.T. Vinutha, Srinivas & M.K. Bhargava

Department of Population Based Cancer Registry, Kidwai Memorial Institute of Oncology, Hosur Road, Bangalore 560029, India

**Summary** A case-control study on cancers of the oral cavity was conducted by utilising data from the population based cancer registry, Bangalore, India. Three hundred and forty-eight cases of cancers of the oral cavity (excluding base tongue) were age and sex matched with controls from the same residential area but with no evidence of cancer. The relative risk due to pan tobacco chewing was elevated in both males and females, being appreciably higher in the latter (relative risk 25.3%; 95% confidence interval 11.2-57.3). A statistically significant (linear test for trend  $P < 0.001$ ) dose response based on years, times per day and period of time chewed was seen. Any smoking (cigarette or bidi or both) had only slightly elevated risk of developing oral cancer, whereas a history of alcohol drinking or inhalation of snuff did not influence the risk. A new finding of our study was the markedly elevated risk of oral cancer in persons consuming ragi (*Eleusine coracana*, family graminae) in comparison to those not consuming ragi as staple cereal in their diet. There also appeared to be some interaction between ragi consumption and tobacco chewing with substantially higher relative risks in those who pursued both habits compared to those who gave a history of either.

Cancers of the oral cavity (ICD sites 140-141, 143-145) constitute one of the leading sites of cancer in men and women in India. The average annual age adjusted incidence rates in Bangalore for these combined sites of cancer is 5.0 per 100,000 in males and 9.3 per 100,000 in females (ICMR Annual Reports). Pan (consisting of betel leaf, areca nut and lime with or without tobacco) chewing is a fairly common social habit particularly in the older population, and the habit is relatively more frequently seen in women than men, as men more often smoke than chew tobacco.

There have been five previous case-control studies on oral cancer from this part of the world (Orr, 1933; Shanta & Krishnamoorthy, 1959, 1963; Hirayama, 1966; Sankaranarayanan *et al.*, 1989) but none of these is population based. This investigation attempts to consider in detail the effects of pan chewing, smoking, alcohol drinking and main dietary habits on the risk of developing oral cancer in the population of Bangalore.

### Subjects and methods

A population-based cancer registry was started at Kidwai Memorial Institute of Oncology, Bangalore from 1 January 1982 as part of the National Cancer Registry Programme of the Indian Council of Medical Research (ICMR, 1982-85; Bhargava & Nandakumar, 1987). The area covered is the resident (at least one year's residence) population of Bangalore Urban Agglomerate.

During the years 1982-84, 6,409 new cases (ICMR, 1985) of cancer were registered in the population based registry. Because of the wide range of diagnostic and therapeutic facilities offered, 73.4% (4,707 new cases) of these were seen at Kidwai Memorial Institute of Oncology at some point of time or the other (ICMR, 1982-85). The diagnostic or therapeutic status of the patient at the time of reference to the Institute varies. Some patients are referred on a mere symptom diagnosis or clinical suspicion of cancer by a general medical practitioner, others with a biopsy diagnosis and few others may have undergone surgery and referred for post operative radiotherapy and/or chemotherapy. However, when first seen, the vast majority of patients referred to the

Institute await complete investigations and confirmation of diagnosis before subsequent treatment.

The cases initially chosen for the study were all registered cancers of ICD sites lip, tongue (excluding base of the tongue), alveolus, and mouth. During the period 1982-84 there were 399 cancers (133 males; 266 females) of these sites. Over 93% of them were microscopically confirmed.

Controls were chosen from among patients who attended Kidwai Memorial Institute of Oncology during the same time period, but who after investigations were proved not to have cancer. One control matched for sex, 5-year age group and area of residence (Bangalore Urban Agglomerate) as the corresponding case was selected. During the period 1982-84 there were 561 resident patients who attended Kidwai Memorial Institute of Oncology for diagnosis of ailments other than that of the oral cavity, but, who on investigation were found not to have any malignancy. Of the 561 subjects 471 were sex and age matched in order of registration to the 475 cases of oral cancer (including base tongue) that were registered during the same period. Four additional controls based on the same criteria were chosen from the first four 'proved non-cancers' of patients attending in 1985. Base tongue cancers (76 cases and their matched controls) were not included in the study.

Information on patients' habits (cases and controls) was sought by direct interview of the subjects by trained social investigators of the department of population based cancer registry. The items on which details were obtained included history of pan chewing with or without tobacco, the number of years since first started chewing, the number of times of chewing per day, as well as the period of time (in minutes) that the pan is retained in the mouth before being spat out or swallowed and whether the person retains the pan in the mouth during sleep. If a history of smoking was present further information on the habit included whether the person smoked bidi (a crude form of cigarette with less refined tobacco) or cigarette or both, the number of years since first started smoking and the actual number smoked per day. Similarly, a history of alcohol consumption included years since first started, frequency and type. Other items were with reference to inhalation of snuff (powdered tobacco), and details of food habits as to whether the subject solely depended on a vegetarian diet or not, the staple cereal consumed and the extent of spiciness of food.

Of the 399 cases details of the above mentioned habits were not available in 51 patients. This left 348 cases and 348 controls for the study.

Correspondence: A. Nandakumar.

Received 30 March 1990; and in revised form 11 June 1990.

1064

Statistical analysis was by conditional logistic regression (Breslow & Day, 1980) which accounted for the matched design of the study and gave odds ratio estimates of relative risks (RR). Ninety-five per cent confidence intervals (CI) were calculated using the standard error of the regression estimates. Risk of one factor was adjusted for the risks of other factors. Those factors that were significant after adjustment of other factors were introduced stepwise into a multivariate model. Dose response was evaluated by tests for trend. Since only one female was a smoker and few females consumed alcohol, analysis for these factors was performed separately for males and females.

## Results

Table I shows the frequency of cases and controls. The average ages of cases and controls were nearly identical. There were slight differences between cases and controls in the proportion of different religions, language spoken and marital status. However, an appreciable difference was observed in the proportion of literates/illiterates among cases and controls. The proportion of literates among controls was more than twice that among cases.

Table II summarises the relative risks associated with smoking habit in males, including type, years and number smoked per day. Cigarette smoking and any smoking was associated with a slightly elevated relative risk and this remained significant after adjusting for the effect of pan tobacco chewing (RR 2.6; 95% CI 1.3-5.2;  $P = 0.01$ ). The relative risk in chewers and smokers was not appreciably different from that in chewers alone. A dose response as indicated by statistically significant elevated relative risks in those persons who gave a history of smoking for more than 25 years, or of smoking more than ten cigarettes/bidis per day was observed. Our investigation showed that snuff inhalation and alcohol consumption in both males and females had minimal influence on the occurrence of oral cancer.

The number of cases and controls, the relative risk estimates and results of significance tests for pan chewing with and without tobacco are shown in Table III. The risk of oral cancer associated with pan tobacco chewing was significantly high in both males and females but the value was substantially higher in females. Pan chewing without tobacco did not increase the risk of oral cancer.

In calculating relative risks for dose-response parameters

Table I Comparative features of cases and controls

	Cases	Controls
Sex		
Male	115	115
Female	233	233
Average age (years)	54.8	55.2
Religion		
Hindu	293	266
Muslim	33	52
Christian	20	27
Others	2	3
Language spoken		
Kannada	110	122
Tamil	76	67
Telugu	96	72
Urdu	31	52
Malayalam	8	4
Others	19	31
Marital status		
Single	11	11
Married	199	238
Widowed	126	96
Divorced	2	1
Separated	4	1
Education		
Illiterate	261 (76.1%)	144 (41.5%)
Literate	82 (23.9%)	203 (58.5%)

and history of chewing during sleep, subjects chewing pan without tobacco were considered as non-chewers. A dose response as indicated by increasing risk for years of chewing, number of times of chewing per day and period of retaining the pan in the mouth was observed (Table IV). A linear test for trend was statistically significant ( $P < 0.001$ ) in all three instances. A history of keeping the pan in the mouth while asleep increased the relative risk two-fold.

Of the food habits that were considered, the main type of cereal consumed influenced the risk of oral cancer. A history of ragi or wheat as the main cereal consumed increased the relative risk several fold especially with respect to consumption of ragi. Subjects were dichotomised into never ragi and ever ragi consumption as the staple cereal (Table V).

Since the proportions of literates and illiterates among cases and controls differed the crude relative risk estimates for ever ragi consumption are shown separately for literates and illiterates with an overall adjusted (Mantel-Haenszel) relative risk as well (Table VI). The influence of educational

Table II Relative risk (RR) estimates and results of significance tests of smoking habits in males

	Cases	Controls	RR	95% CI	P value
Smoking					
No H/o smoking	29	43	1.0	-	-
Cigarette	63	49	2.1	1.1- 4.2	0.03
Bidi	17	19	1.4	0.6- 3.0	0.41
Cigarette + bidi	6	4	2.3	0.6- 8.8	0.23
No H/o smoking	29	43	1.0	-	-
Any smoking	86	72	1.9	1.0- 3.4	0.04
Smoke years					
No H/o smoking	29	43	1.0	-	-
1-5	10	6	2.6	0.8- 8.6	0.12
6-15	9	14	0.9	0.3- 2.7	0.83
16-25	18	18	1.5	0.6- 3.5	0.39
> 25	49	34	2.2	1.1- 4.3	0.02
Smoke (no. day <sup>-1</sup> )					
No H/o smoking	29	43	1.0	-	-
1-10	17	23	1.2	0.6- 2.7	0.63
11-20	37	24	2.5	1.2- 5.4	0.02
> 20	32	25	2.1	1.0- 4.4	0.06
Chewing & smoking					
Neither	14	38	1.0	-	-
Chew only	15	5	10.2	2.6-39.4	< 0.001
Smoke only	69	66	3.5	1.5- 8.2	0.003
Chew + smoke	17	6	9.2	2.6-32.2	< 0.001

CI = confidence interval. H/o = history of.

10965

**Table III** Relative risk (RR) estimates and results of significance tests of chewing habits with and without tobacco

	Cases	Controls	RR	95% CI	P value
<b>Males</b>					
No H/o chewing	68	89	1.0	-	-
Chewing without T	15	15	1.5	0.6-3.8	0.36
Chewing with T	32	11	4.0	1.8-8.9	<0.001
No H/o chewing T	83	104	1.0	-	-
Tobacco chewers	32	11	3.6	1.7-7.9	0.001
<b>Females</b>					
No H/o chewing	19	144	1.0	-	-
Chewing without T	9	30	2.2	0.7-6.5	0.17
Chewing with T	205	59	30.4	12.6-73.4	<0.001
No H/o chewing T	28	174	1.0	-	-
Tobacco chewers	205	59	25.3	11.2-57.3	<0.001
<b>Both sexes</b>					
No H/o chewing	87	233	1.0	-	-
Chewing without T	24	45	1.7	0.9-3.5	0.114
Chewing with T	237	70	14.6	8.2-25.9	<0.001
No H/o chewing T	111	278	1.0	-	-
Tobacco chewers	237	70	12.9	7.5-22.3	<0.001

CI = confidence interval. H/o = history of. T = tobacco.

**Table IV** Relative risk (RR) estimates and results of significance tests of tobacco chewing habits with respect to duration of chewing (years), times per day, chewing period (in minutes) and chewing during sleep (both sexes)

	Cases	Controls	RR	95% CI	P value
<b>Chewing (years)</b>					
No H/o chewing tobacco	111	278	1.0	-	-
1-5	4	6	1.7	0.3-9.3	0.539
6-15	23	7	10.3	3.6-29.6	<0.001
16-25	56	20	12.4	5.6-27.2	<0.001
>25	154	37	15.95	8.4-30.2	<0.001
<b>Chewing (times per day)</b>					
No H/o chewing tobacco	111	278	1.0	-	-
1-4	82	33	9.3	4.9-17.5	<0.001
5-9	98	28	12.8	6.6-25.0	<0.001
≥10	35	8	16.6	6.3-44.3	<0.001
<b>Chewing period (minutes)</b>					
No H/o chewing tobacco	111	278	1.0	-	-
≤5	5	3	6.4	0.9-45.1	0.063
6-10	67	20	9.7	4.7-19.8	<0.001
11-20	59	13	16.5	7.2-37.4	<0.001
21-30	54	17	13.2	5.8-30.0	<0.001
>30	11	6	6.6	1.6-27.0	0.008
<b>Chewing during sleep</b>					
No H/o chewing tobacco	111	278	1.0	-	-
No H/o chewing during sleep	108	47	8.5	4.7-15.2	<0.001
H/o chewing during sleep	103	19	17.7	8.7-36.1	<0.001

CI = confidence interval. H/o = history of.

**Table V** Frequency, relative risk (RR) estimates and results of significance tests of main cereal consumed (both sexes)

Main Cereal	Cases	Controls	RR	95% CI	P value
Rice	187	337	1.0	-	-
Ragi	143	6	29.3	11.9-72.3	<0.001
Jowar	1	2	3.6	0.1-95.4	0.445
Wheat	15	1	15.0	1.98-113.6	0.009
Rice	187	337	1.0	-	-
Ragi	143	6	31.2	12.6-77.4	<0.001
Other	16	3	10.4	2.3-46.3	0.002
No ragi	203	340	1.0	-	-
Ragi	143	6	28.40	11.6-69.3	<0.001

CI = confidence interval.

status was further observed by introducing, stepwise, the variables ever ragi consumption, educational status and history of pan tobacco chewing, into a conditional logistic regression model (Table VII). The risk of ever ragi consumption remained elevated after adjusting for pan tobacco chewing and educational status (RR 27.4; 95% CI 9.9-75.9;  $P < 0.001$ ).

In order to determine whether there was an interaction between pan tobacco chewing and consumption of ragi as the

main cereal, the relative risk in subjects who chewed tobacco as well as consumed ragi was estimated and a marked increase in relative risk (RR 242.6; 95% CI 52.6-1119) was seen, compared to those who chewed tobacco without consuming ragi (RR 12.5; 95% CI 6.3-24.9) or those who consumed ragi without chewing tobacco (RR 32.5; 95% CI 8.8-119.5). Although the estimated risk in a multiplicative model would be  $12.5 \times 32.5 = 406.25$  for significant interaction the estimated risk of 242.6 is very high (Table VIII).

1966

**Table VI** Estimates of crude and adjusted (Mantel & Haenszel) relative risk (RR) and results of significance tests of ever ragi consumption as main cereal and educational status

	Cases	Controls	RR (crude)	95% CI	P value
<i>Literates</i>					
No ragi	53	198	1.0	-	-
Ragi	29	3	36.11	11.3-180.6	<0.001
<i>Illiterates</i>					
No ragi	147	141	1.0	-	-
Ragi	113	3	36.13	11.3-180.7	<0.001
RR (adjusted)					
<i>Literates &amp; illiterates</i>					
No ragi	200	339	1.0	-	-
Ragi	142	6	36.12	15.8-90.3	<0.001

The educational status in 4 cases and 1 control was unknown. CI = confidence interval.

**Table VII** Relative risk (RR) estimates and results of significance tests of ever ragi consumed, educational status and history of pan tobacco chewing in a stepwise model

	RR	95% CI	P value
<i>Ragi &amp; educational status</i>			
Ragi as main cereal (0 = no ragi, 1 = ragi)	26.7	10.6-67.5	<0.001
Educational status (0 = literate, 1 = illiterate)	5.3	3.1-8.9	<0.001
<i>Ragi &amp; pan tobacco chewing</i>			
Ragi as main cereal	26.3	9.8-70.9	<0.001
Pan tobacco chewing (0 = no tobacco, 1 = tobacco)	11.9	6.2-22.8	<0.001
<i>Ragi, educational status &amp; pan tobacco chewing</i>			
Ragi as main cereal	27.4	9.9-75.9	<0.001
Educational status	3.1	1.7-5.9	<0.001
Pan tobacco chewing	8.9	4.5-17.3	<0.001

CI = confidence interval.

**Table VIII** Relative risk (RR) estimates and confidence intervals (CI) of tobacco chewing and ragi consumption habits (both sexes)

<i>Ragi consumption</i>	<i>Tobacco chewing</i>		
		No	Yes
No	RR	1.00	12.5
	(95% CI)	-	(6.3-24.9)
	Cases/cont.	76/272	127/68
Yes	RR	32.5	242.6
	(95% CI)	(8.8-119.5)	(52.6-1119.0)
	Cases/cont.	35/4	108/2

## Discussion

This study confirmed reports of previous investigators (Ellis, 1921; Davidson, 1923; Jussawalla & Deshpande, 1971; IARC, 1985) that pan tobacco chewing is a major risk factor in the occurrence of cancers of the oral cavity. Further, a dose response as measured by chewing years, chewing times per day, period of time chewed and retention of chewing quid overnight while asleep could be clearly demonstrated. In males presence of a history of any smoking was associated with a significantly elevated relative risk. An unexpected new finding of this study, however, was the increased risk when ragi was the staple cereal consumed. This elevated risk was not influenced by any of the other known risk factors and remained unchanged even after stratification and adjusting for educational status, which was thought to be a possible confounder because of differing proportions of literates and illiterates among cases and controls.

Alcohol consumption or snuff inhalation did not emerge as independent risk factors in our study, nor did they enhance or interact with pan tobacco chewing or staple cereal consumed.

The relationship between tobacco either chewed or smoked and development of cancer of the oral cavity is known (Ellis, 1921; Orr, 1933). However, a distinction of anatomic subsites in relating risk factors appears important. By way of embryologic and anatomic development, and also because in pan chewing the anterior tongue and other areas of the mouth are exposed to a greater degree than the base of the tongue, it appears necessary to distinguish this portion of the tongue from the rest of the oral cavity. Our analysis on the risk associated with base tongue cancers is being reported separately.

A statistically significant dose response with respect to chewing habits in this study suggests that certain modifications in chewing habits could substantially reduce the risk of developing oral cancer. The most important of these and perhaps the easiest to follow by the average chewer would be to spit out the pan as early as possible (within 5 min) and not to retain the quid in the mouth overnight while asleep.

Smoking in this study did emerge as an independent risk factor although the strength of the association was greater for pan tobacco chewing. A dose response with smoking could be elicited, but appeared weak. Bidi smoking has been shown to be an independent risk factor for oral cancer by earlier investigators (Sanghvi, 1955; Jussawalla & Deshpande, 1971). We did not find any notable difference in relative risks between bidi and cigarette smokers or in those who smoked both.

Although the extensive study by the IARC (1988) has shown an elevated risk of oral cancers in those who consumed alcohol, our study, like the preceding one (Sankaranarayanan *et al.*, 1989) from this region, did not show any association whatsoever. Any slight elevations in risk were lost once this factor was adjusted for pan tobacco chewing and/or smoking.

An indication of a possible protective effect of dietary factors, like milk, milk products and fish, on the risk of oral cancer has been reported earlier (Notani & Sanghvi, 1976). However, it is for the first time that any relationship of oral cancer to a staple cereal consumed is being suggested. Since questions on diet for this study were asked routinely and not for testing any hypothesis related to diet, the finding here of highly elevated relative risk of oral cancer when ragi (*Eleusine coracina*; family gramineae) was the staple cereal consumed calls for a more detailed assessment of diet and nutritional status in future studies on oral cancer. It is possible that our finding could be confounded by these and other various known and unknown risk factors. Some of these could be in relation to oral hygiene, socioeconomic status and other dietary habits of those consuming rice in contrast to ragi or wheat as the main cereal. Nonetheless, the finding here of substantially elevated risk in ragi consumers is important, particularly because of the marked increase in risk when combined with pan tobacco chewing.

That over 73% of resident cancer patients are referred to

1967

Kidwai Memorial Institute of Oncology (ICMR, 1982-85) makes data collection on a population basis through direct patient interviews relatively easy. An added advantage is the almost total absence of any problem related to confidentiality. The questioning and recording of details of patient habits by the social investigators was done immediately after the patient arrived at the institute and before any clinical examination or investigations. Therefore, the social investigators were not aware of the diagnosis or whether the patient was proved as cancer or not at the time of the interview and any interviewer bias is unlikely. The main limitation of this study is that only one control per case was used and that detailed information on socioeconomic and educational status was not obtained.

In conclusion our study confirmed the role of pan tobacco

chewing, and also demonstrated a significant dose response on the risk of oral cancer, but dietary factors, in particular ragi consumption, appear to enhance that risk considerably.

This study was possible because of the population-based cancer registry commenced by the Indian Council of Medical Research as part of the network of National Cancer Registries in India and the authors gratefully acknowledge the encouragement and funding given by the Council and Dr Usha K. Luthra, Programme Director, National Cancer Registry Programme and Additional Director General, Indian Council of Medical Research. Many thanks are due to Dr Bruce K. Armstrong, Commissioner of Health, Western Australia, for his constructive comments on the earlier drafts of the paper.

#### References

- BHARGAVA, M.K. & NANDAKUMAR, A. (1987). In *Cancer Incidence in Five Continents Vol. V*, Muir, C.S., Waterhouse, J.A.H., Mack, T., Powell, J. & Whelan, S. (eds) p. 408. IARC: Lyon.
- BRESLOW, N.E. & DAY, N.E. (1980). *Statistical Methods in Cancer Research*. IARC: Lyon.
- DAVIDSON, J. (1923). Betel chewing and cancer (correspondence). *Br. Med. J.*, *ii*, 733.
- ELLIS, A.G. (1921). Betel nut chewing and its effects, including cancer of the mouth. *Arch. Intern. Med.*, *28*, 252.
- HIRAYAMA, T. (1966). An epidemiologic study of oral and pharyngeal cancer in Central and South east Asia. *Bull. WHO*, *34*, 41.
- IARC (1985). Evaluation of the carcinogenic risk of chemicals to humans: tobacco habits other than smoking; betel quid and arecanut chewing; and some related nitrosamines. *IARC Monogr.*, *37*, 109.
- IARC (1988). Evaluation of the carcinogenic risk to humans; alcohol drinking. *IARC monogr.*, *44*, 167.
- ICMR (1982-1985). *Annual Reports of National Cancer Registry Project of India (NCRP)*. Indian Council of Medical Research: New Delhi.
- JUSSAWALLA, D.J. & DESHPANDE, V.A. (1971). Evaluation of cancer risk in tobacco chewers and smokers: an epidemiologic assessment. *Cancer*, *28*, 244.
- NOTANI, P.N. & SANGHVI, L.D. (1976). Role of diet in the cancers of the oral cavity. *Ind. J. Cancer*, *13*, 156.
- ORR, I.M. (1933). Oral cancer in betel nut chewers in Travancore. Its aetiology, pathology and treatment. *Lancet*, *ii*, 575.
- SANGHVI, L.D., RAO, K.C.M. & KHANOLKAR, V.R. (1955). Smoking and chewing of tobacco in relation to cancer of upper alimentary tract. *Br. Med. J.*, *i*, 1111.
- SANKARNARAYANAN, R., DUFFY, S.W., DAY, N.E. & 2 others (1989). A case control investigation of cancer of the oral tongue and the floor of the mouth in Southern India. *Int. J. Cancer*, *44*, 617.
- SHANTHA, V. & KRISHNAMOORTHY, S. (1963). A study of aetiology of carcinomas of the upper alimentary tract. *Br. J. Cancer*, *17*, 8.

1968

# Risk factors for cancer of the buccal and labial mucosa in Kerala, southern India

R Sankaranarayanan, Stephen W Duffy, G Padmakumary, Nicholas E Day, M Krishan Nair

## Abstract

**Study objective**—The aim was to investigate risk factors for cancer of the buccal and labial mucosa in Kerala, southern India.

**Design**—The investigation was a case-control study.

**Setting**—Regional Cancer Centre, Trivandrum, Kerala, and local teaching hospitals.

**Participants**—Cases were all those registered with oral cancers at the Regional Cancer Centre during 1983 and 1984 (n=414). Controls (n=895) were selected from admissions to the cancer centre who were found to have non-malignant conditions, or from patients attending outpatients in teaching hospitals of Trivandrum medical college with non-malignant conditions.

**Measurements and main results**—The risk in males of the following habits was investigated: pan (betel)-tobacco chewing, bidi and cigarette smoking, drinking alcohol, and taking snuff. Only pan-tobacco chewing was investigated in females as very few indulged in other habits. Among males predisposing effects were found for pan-tobacco chewing ( $p < 0.001$ ), bidi smoking ( $p < 0.001$ ), drinking alcohol ( $p < 0.001$ ), and taking snuff ( $p < 0.01$ ). As in males, pan-tobacco chewing also had a predisposing effect in females ( $p < 0.001$ ). Duration of use was a better predictor of risk than either daily frequency of use or total lifetime exposure, both for pan-tobacco chewing (especially if the habit started before age 21 years) and bidi smoking. However, there were also very high risks associated with the current occasional use of both factors. Pan-tobacco chewing was the most important risk factor, with relative risk of 13.24 with 31-40 years' use, and 37.75 with > 40 years' use among males. Corresponding relative risks in females were 21.30 and 54.93. No effect of cigarette smoking was observed (relative risk 0.64,  $p > 0.1$ ).

**Conclusions**—A substantial majority of cases of buccal and labial cancers are attributable to chewing pan-tobacco. This has obvious implications for instituting preventive measures.

Cancer of the buccal mucosa is the commonest malignancy among males and the third most common among females in Kerala, India.<sup>1</sup> At the Regional Cancer Centre, Trivandrum, it

constitutes 10.85% and 6.84% of all cancers in men and women respectively. It accounts for more than 50% of all intraoral cancers in southern India.<sup>2</sup> Cancer of the labial mucosa accounts for 0.8% of all cancers seen in our centre.

In the past, risk factors for buccal and labial mucosal cancers have been studied as part of a spectrum of cancers incorporating other intraoral, pharyngeal, laryngeal, and oesophageal cancers. The anatomical sites considered in these studies varied considerably.<sup>3-14</sup> The IARC working group on the evaluation of carcinogenic risk to humans from tobacco habits other than smoking noted that it was not always clear which specific sites were included.<sup>15</sup>

It is possible that the already known risk factors like tobacco chewing, smoking, and alcohol in oral cancers may vary in their relative importance as potential risk factors for cancers of specific intraoral subsites. The fact that cancer of the buccal mucosa is a relatively uncommon intraoral cancer in those communities indulging predominantly in cigarette smoking and/or alcohol<sup>16</sup> also suggests a varying importance of known risk factors in inducing malignancy in different intraoral subsites.

The present study addresses the epidemiology of cancers occurring in the buccal and labial mucosa (hereafter referred to as the buccal mucosa for convenience) in Kerala, India. This state on the southern western coast of India, with a population of 30 million, has three main religious groups: Hindus (59%), Muslims (21%), and Christians (19%). It has the highest literacy rate in the country and the lowest infant mortality, birth rate, and death rate.<sup>17</sup>

## Methods

A hospital based cancer registry was established in the Regional cancer centre, Trivandrum, in 1982, with aid from the Indian Council of Medical Research (ICMR) as part of the National Cancer Registry Project of India. Since then this registry has collected information on all cases of cancer seen at the Regional Cancer Centre and the teaching hospitals of the Medical College, Trivandrum. The data collected include demographic, educational, marital, occupational, socioeconomic, and lifestyle data in addition to clinical details and follow up information, in a standard form.

Four hundred and fourteen patients with cancer of the buccal mucosa (ICD.0 codes 145.0, 1 and 6) and labial mucosa (ICD.0 codes 140.3 and 4) registered by the cancer registry during 1983-1984 constitute the cases for this study. The habit history of these was recorded by direct interviewing of the patients by trained social

Regional Cancer  
Centre, Trivandrum-  
695011, India  
R Sankaranarayanan  
G Padmakumary  
M K Nair  
MRC Biostatistics  
Unit, Cambridge  
CB2 2BW, UK  
S W Duffy  
N E Day

Correspondence to:  
Assistant Professor  
Sankaranarayanan

Accepted for publication  
December 1989

1069

workers, as standard practice of the registry. The habits of interest were pan chewing, pan-tobacco chewing, bidi smoking, cigarette smoking, alcohol and nasal snuff inhalation. The data collected were the daily frequency, the total duration in years, and the age at which the habits were initiated.

Eight hundred and ninety five hospital based controls were selected from patients with non-malignant conditions who initially came to the cancer centre to exclude a diagnosis of malignancy in sites other than head and neck, and from among those attending the outpatient divisions of the teaching hospitals of the medical college with respiratory, intestinal, and genitourinary infections during 1983-1984. The detailed habits of these individuals were collected by the social workers by personal interview in the same form used by the cancer registry.

Pan chewing is defined as chewing of a quid containing fresh betel leaves (*Piper betel*), smeared with aqueous shell lime (calcium hydroxide) and sliced fresh or dried areca nut (*Areca catechu*). Pan-tobacco chewing involves the addition of locally cured dried tobacco leaves and/or stem. No other condiments are added to this mixture in Kerala. Hence the betel quid chewed here is an essentially simpler one than that of northern India, where many spices and other

condiments are added to the basic quid. Bidi is a local cigarette made by wrapping less than 0.5 g of coarse tobacco dust in a dry temburni (*diospyros melanoxylon*) leaf.

The alcoholic beverages used are mainly a locally fermented and distilled sap from palm trees called toddy and/or another locally brewed liquor called "arrack" (approximately 40-60% ethanol). Alcohol consumption in this study has been quantified in terms of frequency of drink per day rather than in millilitres.

The snuff used is home ground tobacco powder, a pinch of which is deeply inhaled into the nostrils.

#### DATA ANALYSIS

Statistical analysis was by unconditional logistic regression producing odds ratio relative risk (RR) estimates and deviance  $\chi^2$  tests for effect.<sup>18</sup> All estimates and tests were adjusted for age. In addition, for males religion was also adjusted for (see results section below) and a multivariate model of risk was constructed by a forward stepwise procedure, eliminating those habits which had no effect on risk when adjusted for other habits. Dose-response was evaluated by tests for trend.<sup>18</sup> Interactions among the effects of risk factors and between risk factors and age were also assessed.

For a small number of the subjects who did indulge in the various habits, but not regularly, the exact daily frequency, duration and age at starting was unknown. Consequently, these occasional users were excluded from the primary analyses of effects of frequency and duration on risk, the effect of occasional use being assessed separately.

#### Results

Table I shows frequencies of cases and controls by age, sex, and religion. Very few subjects (six males and six females) chewed pan alone and the only

Table I Frequency distribution of cases and controls by age, sex, and religion.

Factor	Category	Cases	Controls	Total
Age	<40	21	58	79
	40-49	75	189	264
	50-59	130	306	436
	60-69	115	236	351
	70+	73	106	179
Sex	Male	250	546	796
	Female	164	349	513
Religion	Hindu	269	544	813
	Christian	92	201	293
	Muslim	53	150	203

Table II Frequencies, relative risks and results of significance tests with respect to habit frequencies.

Factor	Category	Cases	Controls	RR	(95% CI)	p <sup>a</sup>	p(trend) <sup>b</sup>
(a) Males							
Pan-tobacco	Never	37	360	1.00	—		
	<5 per day	59	61	9.33	(5.60, 15.22)	p < 0.001	< 0.001
	5-9 per day	75	80	9.04	(5.65, 14.46)		
	10+ per day	69	40	16.36	(9.66, 27.70)		
Bidi	Never	125	402	1.00	—		
	≤10 per day	51	65	2.41	(1.57, 3.68)	p < 0.001	< 0.001
	11-20 per day	43	55	2.50	(1.59, 3.94)		
	21+ per day	17	20	2.81	(1.41, 5.57)		
Cigarette	No	235	499	1.00	—		
	Yes	13	46	0.64	(0.33, 1.22)	NS	NS
Bidi and cigarette	Never	203	459	1.00	—		
	≤10 per day	17	33	1.28	(0.68, 2.36)	NS	NS
	11-20 per day	16	24	1.64	(0.84, 3.21)		
	21+ per day	12	30	0.93	(0.46, 1.87)		
Alcohol	Never	165	438	1.00	—		
	1+ per day	59	71	2.18	(1.46, 3.25)	p < 0.001	NA
Snuff	No	232	532	1.00	—		
	Yes	12	7	3.98	(1.53, 10.34)	p < 0.001	NA
(b) Females							
Pan-tobacco	Never	19	168	1.00	—		
	<5 per day	36	92	3.71	(1.99, 6.99)	p < 0.001	< 0.001
	5-9 per day	72	63	10.83	(5.96, 19.62)		
	10+ per day	35	22	14.24	(6.86, 29.50)		

RR = relative risk; CI = confidence interval; NA = not assessed

<sup>a</sup> Global test for a difference in risk among the categories.

<sup>b</sup> Test on one degree of freedom for linear trend in risk.

1070

habit indulged in by females in substantial numbers was pan-tobacco chewing. Risk was therefore analysed separately for males and females; in the latter case we examined only effects associated with pan-tobacco chewing and omitting chewing of pan alone from risk analysis. Muslim males were at lower risk than Hindu or Christian males, so religion and age were adjusted for in all analyses of the male data. This effect was not observed in the females, so analyses of the female data were adjusted for age only.

Excluding occasional users, numbers of cases and controls, accompanied by age adjusted (and religion adjusted for males) relative risks, and results of significance tests in relation to frequency of habits are shown in table II. In males, predisposing effects were observed of pan-tobacco chewing, bidi smoking, drinking alcohol, and taking snuff. For females, a predisposing effect of pan-tobacco chewing was observed.

The corresponding results for durations of habits are shown in table III. Snuff does not feature in the table as the small number with ascertainable durations render further detailed analysis inadvisable. Results were very similar to those for habit frequencies, showing significant positive associations with risk of pan-tobacco chewing, bidi smoking, and alcohol consumption.

Effects of occasional use are shown in table IV. Significant predisposing effects of occasional use of pan-tobacco, bidi, and alcohol were observed in males, the effects of pan-tobacco and bidi being particularly strong. Although an increased risk was observed in association with occasional pan-tobacco chewing in females, this did not reach statistical significance and the estimate is based on only six subjects positive for the risk factor.

Table V shows relative risks associated with late adoption of the habit (age 21 or over), with analysis restricted to those with the relevant habit. The results are much as expected, a later starting

Table III Frequencies, relative risks and results of significance tests with respect to habit durations (in years).

Factor	Category	Cases	Controls	RR	(95% CI)	p <sup>a</sup>	p(trend) <sup>b</sup>
(a) Males							
Pan-tobacco	Never	37	360	1.00	—	p < 0.001	< 0.001
	≤ 10 per day	11	13	6.90	( 2.83, 16.81)		
	11-20 per day	35	55	5.80	( 3.33, 10.11)		
	21-30 per day	39	49	7.70	( 4.43, 13.38)		
	31-40 per day	48	40	13.24	( 7.51, 23.32)		
	> 41 per day	70	25	37.75	(19.49, 73.12)		
Bidi	Never	125	402	1.00	—	p < 0.001	< 0.001
	≤ 20 per day	17	22	2.68	( 1.35, 5.30)		
	21+ per day	94	118	2.47	( 1.74, 3.49)		
Cigarette	Never	235	499	1.00	—	NS	NS
	≤ 20 per day	4	18	0.60	( 0.19, 1.82)		
	20+ per day	9	28	0.66	( 0.30, 1.44)		
Bidi and cigarette	Never	203	459	1.00	—	NS	NS
	≤ 20 per day	10	23	1.19	( 0.54, 2.59)		
	21+ per day	35	64	1.27	( 0.81, 2.00)		
Alcohol	Never	165	438	1.00	—	p < 0.001	< 0.001
	≤ 21 per day	35	24	1.48	( 0.71, 3.07)		
	21+ per day	47	17	2.50	( 1.59, 3.93)		
(b) Females							
Pan-tobacco	Never	19	168	1.00	—	p < 0.001	< 0.001
	≤ 10 per day	11	48	1.79	( 0.78, 4.07)		
	11-20 per day	22	49	3.80	( 1.85, 7.75)		
	21-30 per day	38	48	7.74	( 4.00, 15.00)		
	31-40 per day	33	19	21.30	( 9.59, 47.36)		
	41+ per day	39	13	54.93	(21.18, 142.42)		

RR = relative risk; CI = confidence interval

<sup>a</sup> Global test for a difference in risk among the categories.

<sup>b</sup> Test on one degree of freedom for linear trend in risk.

Table IV Frequencies, relative risks, and results of significance tests with respect to occasional indulgence in habits.

Factor	Category	Cases	Controls	RR	(95% CI)	p
(a) Males						
Pan-tobacco	Never	37	360	1.00	—	< 0.001
	Occasional	10	5	21.41	(6.54, 70.08)	
Bidi	Never	125	402	1.00	—	< 0.001
	Occasional	14	4	11.25	(3.53, 35.78)	
Cigarette	Never	235	494	1.00	—	NS
	Occasional	2	1	6.69	(0.55, 80.11)	
Bidi and cigarette <sup>a</sup>	Never	203	459	—	—	NS
	Occasional	2	0	—	—	
Alcohol	Never	165	438	1.00	—	< 0.05
	Occasional	26	37	1.81	(1.05, 3.12)	
Snuff	Never	232	532	1.00	—	NS
	Occasional	6	7	2.28	(0.74, 7.03)	
(b) Females						
Pan-tobacco	Never	19	168	1.00	—	NS
	Occasional	2	4	5.42	(0.80, 36.27)	

RR = relative risk; CI = confidence interval

<sup>a</sup> Estimation impossible due to sparse data. Not significant by Fisher's exact test.

1071 &

Table V Relative risks and significance of effect on risk of adopting after age 21 (relative to baseline of before age 21—subjects with habit only).

Habit	RR	95% CI	p
(a) Males			
Pan-tobacco	0.19	(0.11, 0.30)	<0.001
Bidi	0.31	(0.17, 0.53)	<0.001
Cigarette	0.83	(0.20, 3.44)	>0.1
Bidi and cigarette	0.48	(0.21, 1.05)	0.1 > p > 0.05
Alcohol	0.41	(0.19, 0.88)	<0.05
Snuff <sup>a</sup>	4.3 × 10 <sup>-17</sup>	(8.6 × 10 <sup>-32</sup> , 2.3 × 10 <sup>-4</sup> )	<0.05
(b) Females			
Pan-tobacco	0.11	(0.05, 0.20)	<0.001

RR = relative risk; CI = confidence interval  
<sup>a</sup> Very sparse data.

age yielding a reduced risk, and bearing out the duration effects in table III. The results for snuff should not be overinterpreted as the data were sparse (for example, only one control started before age 21).

Table VI gives the results of analysis of total lifetime habits, that is, the product of frequency

and duration, excluding occasional users as before. Results were similar to those for frequency and duration. Examination of residual deviances showed that the effects of lifetime exposures were no more significant predictors of risk than daily frequencies or durations. Again, results for snuff should be interpreted with caution.

The combined effects of frequencies and durations, and of different habits, were further assessed by a forward stepwise logistic regression, eliminating factors no longer significant when adjusted for the effects of other factors. The model finally arrived at contained effects of pan-tobacco duration, bidi duration, and alcohol and snuff use. Results are as shown in table VII.

Neither of the effects of snuff or alcohol use were significant when adjusted for the other, although both were nearly so. Given the small numbers of snuff users and the likelihood of misclassification of alcohol use, it is inadvisable to rule out either habit as a risk factor.

Table VI Frequencies, relative risks, and results of significance tests with respect to total lifetime exposures.

Habit	Case	Control	RR	(95% CI)	p	p(trend)
(a) Males						
Pan-tobacco						
Never	37	360	1.0	—		
<70 chewing years	28	43	6.26	(3.46, 11.29)	<0.001	<0.001
70-139 chewing years	41	47	8.41	(4.86, 14.53)		
140+ chewing years	134	91	14.47	(9.23, 22.69)		
Bidi						
Never	125	402	1.0	—		
<400 bidi years	51	61	2.66	(1.73, 4.08)	<0.001	<0.001
400-499 bidi years	12	27	1.40	(0.68, 2.89)		
500+ bidi years	48	52	2.86	(1.82, 4.49)		
Cigarette						
Never	235	494	1.0	—		
<200 cigarette years	6	20	0.78	(0.30, 2.01)	NS	NS
200+ cigarette years	7	26	0.55	(0.23, 1.30)		
Bidi and cigarette						
Never	203	459	1.0	—		
<600 unit years	32	61	1.34	(0.83, 2.14)	NS	NS
600+ unit years	13	26	1.08	(0.54, 2.16)		
Alcohol						
Never	165	438	1.0	—		
<20 drinking years	8	7	3.79	(1.30, 10.79)	<0.001	<0.001
20+ drinking years	52	66	1.842	(1.33, 3.09)		
Snuff						
Never	232	532	1.0	—		
<100 unit years	7	1	15.66	(1.95, 125.28)	<0.005	<0.001
100+ unit years	5	6	1.95	(0.57, 6.61)		
(b) Females						
Pan-tobacco						
Never	19	168	1.0	—		
<70 chewing years	17	79	1.89	(0.91, 3.88)	<0.001	<0.001
70+ chewing years	37	48	7.49	(3.86, 14.53)		
140+ chewing years	89	50	19.41	(10.30, 36.57)		

RR = relative risk; CI = confidence interval

Table VII Relative risk estimates among males and results of significance tests for the four factors resulting from forward stepwise regression.

Factor	Category <sup>a</sup>	RR <sup>b</sup>	(95% CI)	p <sup>b</sup>
Pan-tobacco duration	Never	1.00	—	
	≤10 years	7.12	(2.77, 18.24)	<0.001
	11-20	4.46	(2.44, 8.14)	
	21-30	6.44	(3.53, 11.74)	
	31-40	11.15	(5.95, 20.87)	
40+ years	29.02	(14.20, 59.28)		
Bidi duration	Never	1.00	—	
	≤20 years	2.90	(1.26, 6.64)	<0.01
	21+ years	1.66	(1.06, 2.60)	
Alcohol	Never	1.00	—	
	Ever	1.60	(0.99, 2.57)	0.1 > p > 0.05
Snuff	Never	1.00	—	
	Ever	2.93	(0.98, 8.77)	0.1 > p > 0.05

RR = relative risk; CI = confidence interval

<sup>a</sup> Excluding occasional users.

<sup>b</sup> All estimates and tests adjusted for the effects of the remaining three factors.

In males we observed significant interactions with age of pan-tobacco duration (p < 0.001) and alcohol duration (p < 0.05). Age specific relative risks for these variables are given in table VIII. Although in those aged under 50 the confidence intervals are wide, the relative risks are indubitably larger than in those aged 50 or more.

In females, significant interactions with age were observed for frequency and duration (p < 0.05 in both cases) of pan-tobacco chewing. Again, the excess risk conferred by the habit was greater in the younger age group (see table IX).

To examine further the interactions of age and pan-tobacco duration in males and females, we excluded those who did not have the habit or who only occasionally chewed, and tested the interaction after adjustment for age at the start of the habit. In both males and females, the

1072

Table VIII Age specific relative risks associated with durations of pan-tobacco chewing and alcohol drinking in males.

Risk factor	Category	Age < 50		Age 50+	
		RR	(95% CI)	RR	(95% CI)
Pan-tobacco duration (years)	Never	1.00	—	1.00	—
	≤ 10	14.21	( 3.56, 56.60)	8.61	( 2.16, 34.32)
	11-20	22.90	( 7.46, 70.23)	3.26	( 1.56, 6.77)
	21-30	71.30	(19.37, 262.49)	3.53	( 1.81, 6.85)
	31-40*	—	—	8.50	( 4.77, 15.13)
	41+*	—	—	26.29	(13.70, 50.40)
Alcohol duration (years)	Never	1.00	—	1.00	—
	≤ 20	2.77	( 0.95, 8.04)	0.92	( 0.32, 2.64)
	21+	8.18	( 2.79, 23.95)	1.89	( 1.13, 3.14)

RR = relative risk; CI = confidence interval

\* Inestimable in younger group due to lack of data.

Table IX Age specific relative risks associated with frequency and duration of pan-tobacco chewing among females.

Risk factor	Category	Age < 50		Age 50+	
		RR	(95% CI)	RR	(95% CI)
Pan-tobacco daily frequency	Never	1.00	—	1.00	—
	< 5	17.85	( 3.24, 98.09)	2.59	( 1.31, 5.11)
	5-9	100.28	(17.44, 576.35)	6.45	( 3.39, 12.24)
	10+	53.62	( 6.94, 414.18)	10.55	( 4.84, 23.00)
Pan-tobacco duration (years)	Never	1.00	—	1.00	—
	≤ 10	21.39	( 2.76, 165.55)	0.76	( 0.25, 2.26)
	11-20	30.08	( 3.97, 227.41)	2.03	( 0.88, 4.62)
	21-30	217.89	(25.98, 1827.31)	2.99	( 1.40, 6.39)
	31-40*	—	—	12.19	( 5.53, 26.89)
	41+*	—	—	31.31	(12.35, 79.37)

RR = relative risk; CI = confidence interval

\* Inestimable in younger group due to lack of data.

interaction of duration with age lost its significance. It therefore seems likely that these interactions are in effect products of the substantial increase in risk conferred by starting the habit at or before age 20 years (see table V). This was also the case for the interaction of age with duration of alcohol consumption in males.

Interactions among habits were assessed by first dichotomising habits to 'never/ever' to avoid the difficulties of interpretation and insensitivity arising from sparse data. The only two factor interaction observed was between pan-tobacco chewing and bidi smoking ( $p < 0.05$ ). As can be seen from table X, the cumulative effect of both habits is represented by a relative risk of 21.46 (relative to a baseline of neither habit), and not 60.12, the product of 14.28 and 4.21 which we would expect were there no interaction.

No significant three factor interactions were observed. To illustrate the cumulative effect on risk of three predisposing factors in the absence of such an interaction, table XI shows relative risks by pan-tobacco chewing, bidi smoking, and alcohol use. The baseline group is made up of those never indulging in any of the three habits.

In considering risk stratified by several factors, note that with sufficient data to quantify the habits, the relative risk gradients would almost certainly be larger.

### Discussion

This study reveals pan-tobacco chewing to be the major risk factor for cancer of the buccal and labial mucosa. Previous case-control studies in various parts of India on cancer of the buccal and labial mucosa have resulted in relative risk estimates ranging from 3.9 to 39.<sup>5, 8, 19, 20</sup> Relative risk

estimates here suggest that daily frequency and early age of starting pan-tobacco chewing are the major predictors of risk. Dose-response relationships between relative risk and frequency/duration of chewing have not previously been examined in detail in India. The working group of the IARC was able to calculate the dose-response relationship between daily frequency of chewing and oral cancer risks in only two studies reported from India.<sup>7, 21</sup> This is probably the first study from India which examines the dose-response in terms of duration of chewing in years and total life time exposure (chewing years = the product of daily frequency and duration of chewing in years).

Buccal mucosa seems to be the site at greater risk of malignancy in pan-tobacco chewers as compared to other intraoral sites. This is suggested by the higher proportion of buccal mucosa cancers in Bangalore, Madras, and Singapore Indians<sup>16</sup> (who are ethnically south Indians), where betel quid chewing is more common than in northern India. In Bombay, Poona and Nagpur, the tongue is the predominant site of intraoral cancer.<sup>16</sup> The highest age adjusted rate for buccal mucosal cancers is reported in Madras for males and in Bangalore for females. The dominant habit in these areas is chewing pan with tobacco. The predominant occurrence of malignancy in the buccal mucosa among chewers is probably due to the constant contact with the quid while chewing. In early studies, the highest relative risks have been related to retaining the quid during sleep.<sup>7</sup>

It is likely that carcinogens in the quid act as contact carcinogens. In spite of many studies evaluating the carcinogenicity of various betel quid constituents, the carcinogens in the quid have not been unequivocally identified. However these studies indicate that all the components of pan-tobacco with the probable exception of betel leaf are likely to contribute to oral carcinogenicity.<sup>15</sup> Nicotine contributes to the carcinogenic potential of tobacco by serving as precursor to many tobacco specific nitrosamines such as NNN (N-nitrosornicotine) and NNK (4-(methyl nitrosamino)-1-(3-pyridyl)-1-butanone) which have proved their carcinogenicity in experimental animals. Local irritation and the alkalinity induced by lime and some of the arecanut specific nitrosamines like MNP (3[nitrosamino] propionitrile) with proven carcinogenicity in animals<sup>22</sup> may also contribute to oral neoplastic processes.

The other quid related factors that may modify the carcinogenic potential include the differences in the proportion of various quid components, duration of each chew, and whether the chewer rinses the oral cavity with water after each and/or frequent chews. It is almost impossible to examine the effect of the first mentioned factor, but the latter two should be addressed in future studies. Evaluation of the last factor may have some public health significance.

The finding of an evident interaction between duration of pan-tobacco chewing and age, and the absence of its significance when adjusted for age at adoption of habit, indicate that the effect of the latter is not simply a proxy for duration. There may be a period of particularly high susceptibility to the carcinogenic effect before age 21.

1073

Bidi smoking has emerged as an independent risk factor for cancer of the buccal and labial mucosa in our study. Jussawalla and Deshpande have reported a relative risk of 1.5 for buccal mucosa with smoking.<sup>8</sup> However, in two earlier case control studies from Madras,<sup>5,19</sup> the proportion of smokers was higher in controls (47% and 53.7% respectively) compared to cases (26% and 46%). Bidi is the most popular form of tobacco smoked among the lower socioeconomic strata in India, as it is very cheap. The bidi industry is currently promoted by many state governments in India, as a cottage industry, providing employment to many people. Unlike cigarette packs, packs of bidi do not carry the statutory warning on the health hazards of tobacco smoking. A comparative chemical study of bidi with a popular brand of American cigarette without filter revealed that a single bidi delivers about one and a half times the carcinogenic hydrocarbons delivered by a cigarette when it is smoked with two puffs per minute.<sup>23</sup> The daily frequency seems to be the major predictor of risk with bidi smoking also.

Cigarette smoking and combined bidi plus cigarette smoking have not emerged as independent risk factors in this study. It might be speculated that this is due to small numbers, but this seems unlikely in view of the seemingly protective (but non-significant) effect of cigarette smoking. The results indicate a qualitative difference between bidi and cigarette smoke.

Alcohol as a risk factor in oral cancer has not been studied in detail in India. There is only one recent study from India which addresses this question with oral cancer (ICD 140, 141, 143-145).<sup>10</sup> The reported relative risks with alcohol for oral cancer were 3.6, 2.6, 0.9 and 0.4 for those under 40 years of age, 40-49 years, 50-59 years,

and > 60 years of age respectively. The adjusted odds ratio of alcohol consumption in those under 60 years of age ranged from 1.3 and 3.6 and no association was reported between alcohol consumption and oral cancer in those above 60 years of age.

The two earlier case-control studies from Madras, on buccal mucosal and labial cancer, reported the proportion of drinkers among cases as less than 20% but the details were not available for controls so risk estimates were not possible.

Alcohol did not emerge as a particularly strong risk factor of buccal and labial mucosal cancer in our study after adjusting for other factors, but this has to be interpreted with caution as there is a likelihood of underreporting of alcohol habit among our population. Alcohol consumption is considered to be a social evil in Indian society and many have a reluctance to reveal this habit. There is a need for further studies in India into the role of alcohol in cancers of this and other intraoral sites.

Snuff inhalation has emerged as an independent risk factor in our study. This has not been studied in the previous investigations in India. The number of subjects with this habit is limited. Biologically it is difficult to explain how the inhaled snuff comes into contact with buccal and labial mucosa. It is possible that those who use snuff may also smear the oral mucosa unknowingly. It should be borne in mind that the snuff habit is rare and we should prefer to see these results confirmed by other studies before accepting them.

Jayant *et al*<sup>9</sup> have studied the interaction between chewing and smoking in the aetiology of oral cancer, and Notani<sup>10</sup> has reported the relative risks associated with combined habits of chewing and alcohol with or without smoking. The relative risks were 4.7 with smoking; 2.8 with chewing; 13.1 with smoking and chewing; 10 with alcohol and chewing; 17.8 with alcohol and smoking; and 47.1 for alcohol, smoking and chewing. In this study, chewing was found to be the most important factor, and alcohol to have a marginal effect.

The form of the interaction with age observed for frequency of pan-tobacco chewing among females was surprising, in that the effect was so much stronger among younger women. Possible explanations for this are the small number of cases under 40 years of age, and the likelihood that increased misclassification among the elderly is diluting the effect of the risk factor. The effect of unobserved covariates, for example dietary factors, cannot be ruled out.

While the stepwise analysis indicated that duration of habit was more important than frequency for pan-tobacco chewing and bidi smoking, the high risks conferred by occasional indulgence suggest that there is always an incentive for giving up the habit. The very high risks observed for occasional users remain to be explained.

Finally, it is interesting to consider risks attributable to chewing and smoking respectively. From table X we calculate (using average attributable risks weighted by numbers of cases) that 19% of cases could be prevented by eliminating bidi smoking alone, 73% could be prevented by elimination of pan-tobacco chewing alone, and 85% could be prevented by elimination

Table X Relative risks and frequencies of cases and controls by pan-tobacco and bidi habits in males.

Bidi smoking		RR (95% CI) Cases/controls	Pan-tobacco chewing	
			Never	Ever
Never		1.00	1.00	14.28 (8.21, 24.83)
		18/284		103/114
Ever		4.21 (2.09, 8.45)	4.21 (2.09, 8.45)	21.46 (11.94, 38.54)
		19/74	19/74	87/65

RR = relative risk; CI = confidence interval

Table XI Combined effects of pan-tobacco chewing, bidi smoking, and alcohol use in males, the baseline group being those with none of the three habits.

Bidi smoking		RR (95% CI)	Alcohol use	
			Never	Ever
Never		1.00	(a) Never chew pan-tobacco	
		1.00	1.00	2.55 (0.77, 8.40)
Ever		4.06 (1.80, 9.13)	4.06 (1.80, 9.13)	8.48 (2.26, 31.79)
		14.11 (7.49, 26.56)	14.11 (7.49, 26.56)	20.05 (9.13, 43.97)
Never		20.97 (10.66, 41.24)	(b) Ever chew pan-tobacco	
		20.97 (10.66, 41.24)	20.97 (10.66, 41.24)	31.37 (13.13, 74.94)

RR = relative risk; CI = confidence interval

1074 R

of both habits. These results are tentative, in view of the interaction between the two habits mentioned above. Nevertheless, the indication is that a substantial majority of cases are attributable to chewing of pan-tobacco.

The first author's program at MRC Biostatistic Unit, Cambridge, was funded by Commonwealth Scholarship Commission, UK. The hospital cancer registry at the Regional Cancer Centre, Trivandrum, is supported by the Indian Council of Medical Research (ICMR). The authors gratefully acknowledge Anita Nayar, Jalaja Kumary, and P T Latha who were involved in interviewing the subjects, Ziva Gombedza for computing assistance, and Eve Swale for the preparation of this manuscript.

- 1 Krishnan Nair M, Sankaranarayanan R, Padmanabhan TK, Padmakumari G. Clinical profile of 2007 oral cancers in Kerala, India. *Ann Dent* 1988; 47: 23-6.
- 2 Annual Reports of National Cancer Registry Project of India, 1982-1985. New Delhi: Indian Council of Medical Research (ICMR).
- 3 Sanghvi LD, Rao KCM, Khanolkar VR. Smoking and chewing of tobacco in relation to cancer of the upper alimentary tract. *Br Med J* 1955; i: 1111-4.
- 4 Khanolkar VR. Oral Cancer in India. *Umo Int Contra Cancrum Acta* 1959; 15: 67-77.
- 5 Shanta V, Krishnamoorthy S. Further study in aetiology of carcinomas of the upper alimentary tract. *Br J Cancer* 1963; 17: 8-23.
- 6 Wahi PN, Kchar U, Lahiri B. Factors influencing oral and oropharyngeal cancers in India. *Br J Cancer* 1965; 19: 642-60.
- 7 Hirayama T. An epidemiologic study of oral and pharyngeal cancer in central and southeast Asia. *Bull WHO* 1966; 34: 41-69.
- 8 Jussawalla DJ, Deshpande VA. Evaluation of cancer risk in tobacco chewers and smokers: an epidemiologic assessment. *Cancer* 1971; 28: 244-52.
- 9 Jayant K, Balakrishnan V, Sanghvi LD, Jussawalla DJ. Quantification of the role of smoking and chewing tobacco in oral, pharyngeal and oesophageal cancers. *Br J Cancer* 1977; 35: 232-5.
- 10 Notani PN. Role of alcohol in cancers of the upper alimentary tract: use of models in risk assessment. *J Epidemiol Community Health* 1988; 42: 187-92.
- 11 Wynder EL, Bross IJ, Feldman RM. A study of the etiological factors in cancer of the mouth. *Cancer* 1957; 10: 1300-23.
- 12 Rothman K, Keller AZ. The effect of joint exposure to alcohol and tobacco on risk of cancer of mouth and pharynx. *J Chron Dis* 1972; 25: 711-6.
- 13 Graham S, Dayal H, Roherer T, et al. Dentition, diet, tobacco and alcohol in the epidemiology of oral cancer. *J Natl Cancer Inst* 1977; 59: 1611-8.
- 14 Elwood JM, Pearson JCH, Skipin DH, Jackson SM. Alcohol, smoking, social and occupational factors in the aetiology of cancer of the oral cavity, pharynx and larynx. *Int J Cancer* 1984; 34: 603-12.
- 15 IARC. Monograph. Evaluation of the carcinogenic risk of chemicals to humans: Tobacco habits other than smoking; betel quid and areca nut chewing; and some related nitrosamines. Vol 37. Lyon, France: International Agency for Research on Cancer, 1987.
- 16 Muir C, Waterhouse J, Mack T, et al, eds. *Cancer incidence in five continents*. Vol 5. Lyon, France: International Agency for Research on Cancer, 1988.
- 17 Nag M. The Kerala formula. *World Health Forum* 1988; 9: 252-68.
- 18 Breslow NE, Day NE. *Statistical methods in cancer research. Analysis of case control studies*. Lyon, France: IARC, 1980.
- 19 Shanta V, Krishnamoorthy S. A study of aetiological factors in oral squamous cell carcinoma. *Br J Cancer* 1959; 13: 381-8.
- 20 Chandra A. Different habits and their relation with cancer of the cheek. Chittaranjan Cancer Hospital, Calcutta. *Natl Cancer Res Bull* 1962; 33-6.
- 21 Orr IM. Oral cancer in betel nut chewers in Travancore. Its aetiology, pathology and treatment. *Lancet* 1933; ii: 575-80.
- 22 Prokopczyk B, Rivenson A, Bertinato P, et al. 3-(Methylnitrosamino) propionitrile; occurrence in saliva of betel quid chewers, carcinogenicity and DNA methylation in F 344 rats. *Cancer Res* 1987; 47: 461-71.
- 23 Hoffman D, Sanghvi LD, Wynder EL. Comparative chemical analysis of Indian bidi and American cigarette smoke. *Int J Cancer* 1974; 14: 49-55.

1075 R

**Tobacco consumption practices and risk of oro-pharyngeal cancer: a case-control study in Central India**

Wasnik, K.S.; Ughade, S.N.; Zodpey, S.P.; Ingole, D.L.

Southeast Asian J. Trop. Med. Public Health 1998; 29 (4): 827-834

A hospital based, group matched case control study was conducted with the objective to assess the association between tobacco consumption practices and risk of development of oro-pharyngeal cancer in Central India. The study included 123 cases of oro-pharyngeal cancer, diagnosed on the basis of histopathology at three tertiary care centers in Nagpur city. Each case was matched for age and sex with two hospital controls: one selected from non-cancer patients and another from patients having cancer of other sites. Tobacco chewing (OR=7.98, 95% CI 4.11-13.58) and tobacco smoking (OR=2.25, 95% CI 1.22-3.70) were found to be significantly associated with oro-pharyngeal cancer on unconditional multiple logistic regression analysis. Further analysis revealed a dose-response relationship between increasing frequency, duration and retention time of tobacco in mouth and risk of oro-pharyngeal cancer. Other risk factors which were also found to contribute significantly in the outcome of oro-pharyngeal cancer in the study population were: use of traditional/local substances (eg pan, betel nut, lime) with or without tobacco, use of tobacco containing material for teeth cleaning, type of smoking (eg bidi, chillum, cigarette) and outdoor occupations. High values of estimates of attributable risk percent (ARP) and population attributable risk percent (PARP) confirmed the positive impact of reduction or elimination of the tobacco consumption practices on reducing the risk of oro-pharyngeal cancer in the population of Central India

# Head and neck cancer in the betel quid chewing area: recent advances in molecular carcinogenesis

Yin-Ju Chen,<sup>1</sup> Joseph Tung-Chieh Chang,<sup>2,7</sup> Chun-Ta Liao,<sup>3,7</sup> Hung-Ming Wang,<sup>4,7</sup> Tzu-Chen Yen,<sup>5,7</sup> Ching-Chi Chiu,<sup>1</sup> Ya-Ching Lu,<sup>1</sup> Hsiao-Fang Li<sup>1</sup> and Ann-Joy Cheng<sup>6,7,8</sup>

<sup>1</sup>Graduate Institute of Biomedical Science, Chang Gung University, 259 Wen-Hwa 1<sup>st</sup> Road, Taoyuan 333; <sup>2</sup>Department of Radiation Oncology, Chang Gung Memorial Hospital, 5 Fu-Shin Road, Taoyuan 333; <sup>3</sup>Department of Otorhinolaryngology, Head Neck Surgery, Chang Gung Memorial Hospital, 5 Fu-Shin Road, Taoyuan 333; <sup>4</sup>Department of Medical Oncology, Chang Gung Memorial Hospital, 5 Fu-Shin Road, Taoyuan 333; <sup>5</sup>Molecular Imaging Center and Department of Nuclear Medicine, Chang Gung Memorial Hospital, 5 Fu-Shin Road, Taoyuan 333; <sup>6</sup>Department of Medical Biotechnology, Chang Gung University, 259 Wen-Hwa 1<sup>st</sup> Road, Taoyuan 333; <sup>7</sup>Taipei Chang Gung Oncology Group, Chang Gung Memorial Hospital and Chang Gung University, Taoyuan 333, Taiwan

(Received February 29, 2008/Revised April 11, 2008/Accepted April 15, 2008/Online publication July 29, 2008)

Head and neck cancer (HNC) is one of the 10 most frequent cancers worldwide, with an estimated over 500 000 new cases being diagnosed annually. The overall 5-year survival rate in patients with HNC is one of the lowest among common malignant neoplasms and has not significantly changed during the last two decades. Oral cavity squamous cell carcinoma (OSCC) shares part of HNC and has been reported to be increasing in the betel quid chewing area in recent years. During 2006, OSCC has become the sixth most common type of cancer in Taiwan, and it is also the fourth most common type of cancer among men. It follows that this type of cancer wreaks a high social and personal cost. Environmental carcinogens such as betel quid chewing, tobacco smoking and alcohol drinking have been identified as major risk factors for head and neck cancer. There is growing interest in understanding the relationship between genetic susceptibility and the prevalent environmental carcinogens for HNC prevention. Within this review, we discuss the molecular and cellular aspects of HNC carcinogenesis in Taiwan, an endemic betel quid chewing area. Knowledge of molecular carcinogenesis of HNC may provide critical clues for diagnosis, prognosis, individualization of therapy and molecular therapeutics. (*Cancer Sci* 2008; 99: 1507–1514)

Head and neck cancer (HNC) is one of the 10 most frequent cancers worldwide,<sup>(1)</sup> with an estimated over 500 000 new cases being diagnosed annually.<sup>(1)</sup> Squamous cell carcinoma represents more than 95% of all head and neck cancers. Therefore the HNC problem primarily concerns the diagnosis, biology and management of squamous cell carcinoma.<sup>(1)</sup>

According to the 9th revision of the International Classification of Diseases (ICD-9), the term HNC relates to malignant neoplasms of the lip (ICD140), tongue (ICD141), gum (ICD143), floor of the mouth (ICD 144), bucca and other unspecified parts of mouth (ICD145), oropharynx (ICD146), hypopharynx (ICD148) and other head and neck sites (ICD149). The World Health Organization (WHO) estimated that the global incidence rate for cancer of the head and neck in 2000 was 14.27 per 100 000. However, the prevalence of HNC differs greatly in different parts of the world. Epidemiologic studies have shown a wide variation of incidence between worldwide areas. HNC is highly prevalent in South-east Asia, comprising 35–40% of all malignancies in India, compared with approximately 9% in Taiwan and 2–4% in Western countries.<sup>(2,3)</sup> Also, the tumor sites of HNC are discrete from various regions. Cancers of tongue and buccal mucosa constitute the majority of HNC in India and Taiwan.<sup>(2–5)</sup> In contrast, the Western registries show cancers of the mouth floor are the most frequent, with cancer of gum or

tongue being rare.<sup>(2,3)</sup> The differences may be attributed to certain environmental exposures prevalent in this population, as well as to genetic factors.

Within this paper, we review the Taiwanese studies on the epidemiology of HNC, features of premalignant lesions, potential carcinogens associated with susceptibility and prognosis and molecular mechanisms of tumorigenesis.

## Descriptive epidemiology of head and neck cancer in Taiwan

The incidence of HNC is one of the highest in the world, and this malignancy has been one of the 10 leading causes of cancer deaths in Taiwan (Table 1). All the epidemiology data are from the Cancer Registry Annual Report of Taiwan, Health and National Health Insurance Annual Statistics Information Service, Department of Health, Executive Yuan, ROC Taiwan (<http://www.doh.gov.tw/statistic/index.htm>). In 1982, the incidence rate of HNC was 5.12 per 100 000 people in males and 1.54 per 100 000 people in females (Fig. 1). In 1991, the incidence rate of HNC had not much changed, with 6.02 and 1.51 per 100 000 people in males and females, respectively. However, in 2003, the incidence rate of HNC significantly increased to 35.08 and 3.56 per 100 000 people in males and females, an alarming 5.82-fold increase in men and 2.35-fold increase in woman in a decade (Fig. 1). In 2006, oral cavity squamous cell carcinoma (OSCC) had become the 6th most common cancer in Taiwan and the 4th most common cancer in Taiwanese men (Table 1). Similarly, mortality rate also increased significantly, from 4.25 per 100 000 in 1995 to 9.6 per 100 000 in 2006, a 2.26-fold increase in the past decade (Fig. 2). This unfavorable trend reflects the increased mortality rate from HNC mostly in men. Overall, mortality rates for HNC in males increased 2.33-fold, from 7.6 per 100 000 in 1995 to 17.7 in 2006 (Fig. 2). Given the magnitude of the HNC problem in Taiwan and its profound adverse impact on public health, there is a need for intervention and the initiation of preventive actions.

There has been a trend toward lower age at diagnosis of HNC over time. From 1989 to 1993, the peak of incident rate was for people aged 50–59 years, but this shifted to ages 40–49 years between 1993 and 2000 (Fig. 3). A similar trend was also found in the mortality rate. During the period between 1991 and 1994,

\*To whom correspondence should be addressed. E-mail: [ajchen@mail.cgu.edu.tw](mailto:ajchen@mail.cgu.edu.tw)

Table 1. The ten most common cancers in Taiwan, 2006

Rank	All incidence	Mortality	Male incidence	Male mortality
1	Lung	Liver	Liver	Liver
2	Liver	Lung	Lung	Lung
3	Colon-rectum	Colon-rectum	Colon-rectum	Colon-rectum
4	Breast (F)	Stomach	Oral cavity	Oral cavity
5	Stomach	Oral cavity (F)	Stomach	Stomach
6	Oral cavity (F)	Breast (F)	Esophagus	Esophagus
7	Prostate	Esophagus	Pancreas	Prostate
8	Cervix	Pancreas	Prostate	Pancreas
9	Esophagus	Non-Hodgkin lymphoma	Non-Hodgkin lymphoma	Non-Hodgkin lymphoma
10	Pancreas	Gallbladder	Nasopharynx	Nasopharynx

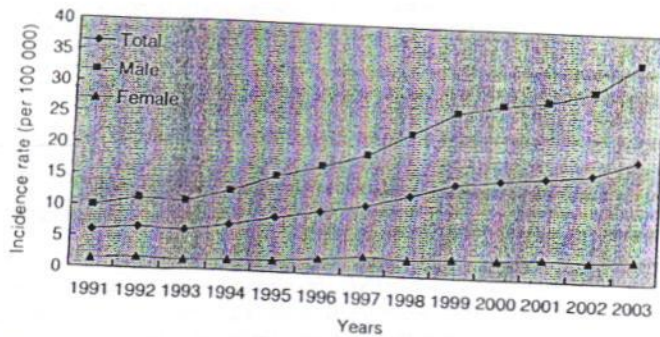

Fig. 1. The incidence rate (per 100 000) of head and neck cancer in Taiwan by sex between 1991 and 2003.

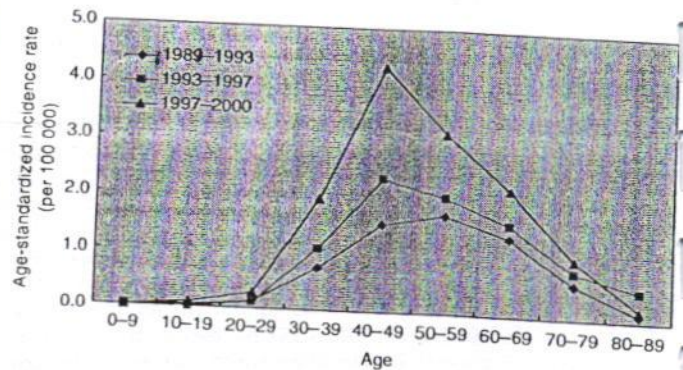

Fig. 3. The age-standardized incidence rate (per 100 000) of oral cavity cancer in Taiwan between 1989 and 2000.

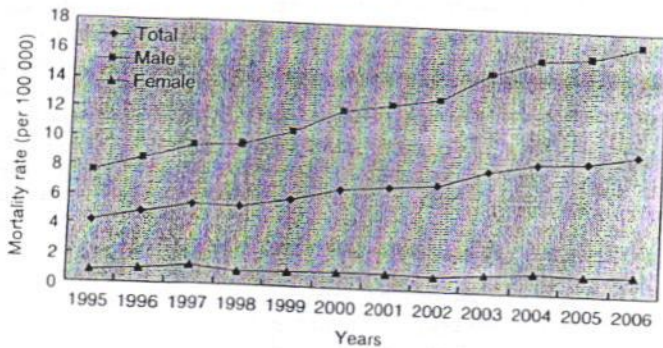

Fig. 2. The mortality rate (per 100 000) of head and neck cancer in Taiwan by sex between 1995 and 2006.

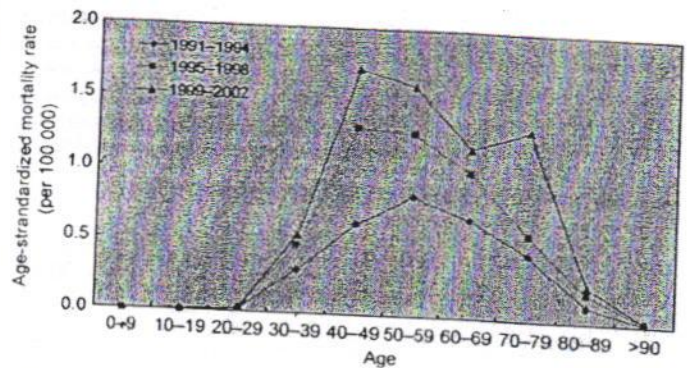

Fig. 4. The age-standardized mortality rate (per 100 000) of oral cavity cancer in Taiwan between 1991 and 2002.

mortality rate peaked at age 50-59 years, but shifted to age 40-49 years between 1999 and 2002 (Fig. 4). (<http://www.doh.gov.tw/statistic/index.htm>). These data are consistent with other regional reports from northern and southern Taiwan.<sup>(5-7)</sup> Moreover, patients with HNC are generally younger than those with other forms of cancer. In 2006, the median age at death from HNC was 54 years compared with 69 years in other forms of cancer.

Gender differences in HNC have been described, with a marked male predominance. A study analyzing 703 OSCC patients between 1985 and 1996 in southern Taiwan found a 51:1 male-to-female ratio.<sup>(7)</sup> Our previous studies in oral cavity cancer patients demonstrated that male cases were far more common than females, comprising 90-93% men and 7-10% women.<sup>(4,5,8)</sup> This gender difference may be explained by the lower proportion of betel quid chewing habits in females. Concerns about the disfiguring effects of areca quid chewing

(including red staining of lips and teeth and foul-smelling breath) are frequently reported by females, which may account for sex differences in HNC prevalence.

The overall 5-year survival rate in patients with HNC is one of the lowest among common malignant neoplasms and has not significantly changed during the last two decades.<sup>(1)</sup> Cancer tumor stage (Table 2) is the major determinant of survival rate. The 5-year survival rates of oral cavity cancer patients in stages I, II, III and IV are 72-90%, 39-85%, 27-70% and 12-50%, respectively.<sup>(5,8,9)</sup> Survival rates for HNC are significantly influenced by tumor size, lymph node involvement, distant metastasis, tumor differentiation and betel quid chewing.<sup>(4,5)</sup> Chewing betel quid independently contributes to the risk of HNC, and the estimated prevalence of betel quid chewing in Taiwanese patients with HNC is approximately 85%.<sup>(4,5,8)</sup> Approximately 50% of

1078  
6

Table 2. Clinical staging of oral cavity cancer based on American Joint Committee on Cancer (AJCC) system. (Greene FL et al. ed. AJCC Cancer Staging Manual, 6th edn, 2002, Springer). The assessment of the primary tumor is based on inspection and palpation of the oral cavity and neck. Additional studies may include computed axial tomography (CT) or magnetic resonance imaging (MRI). Clinical stage is grouped based on the status of primary tumor (T), regional lymph nodes (N) and distant metastasis (M)

Definition of primary tumor (T)			
TX	Primary tumor cannot be assessed		
T0	No evidence of primary tumor		
Tis	Carcinoma <i>in situ</i>		
T1	Tumor 2 cm or less in greatest dimension		
T2	Tumor more than 2 cm but not more than 4 cm in greatest dimension		
T3	Tumor more than 4 cm in greatest dimension		
T4	Tumor invades through cortical bone, inferior alveolar nerve, floor of mouth or skin of face		
T4a	Tumor invades adjacent structures		
T4b	Tumor invades masticator space, pterygoid plates, or skull base		
Definition of regional lymph nodes (N)			
Nx	Regional lymph nodes cannot be assessed		
N0	No regional lymph node metastasis		
N1	Metastasis in a single ipsilateral lymph node, 3 cm or less in greatest dimension		
N2	Metastasis in a single ipsilateral lymph node, more than 3 cm but not more than 6 cm in greatest dimension, or in multiple ipsilateral or in bilateral or contralateral lymph nodes, none more than 6 cm in greatest dimension		
N3	Metastasis in a lymph node more than 6 cm in greatest dimension		
Definition of distant metastasis (M)			
Mx	Distant metastasis cannot be assessed		
M0	No distant metastasis		
M1	Distant metastasis		
Clinical stage grouping			
Stage 0	Tis	N0	M0
Stage I	T1	N0	M0
Stage II	T2	N0	M0
Stage III	T3	N0	M0
	T1-3	N1	M0
Stage IVA	T4a	N0-2	M0
	T1-3	N2	M0
Stage IVB	T4b	any N	M0
	any T	N3	M0
Stage IVC	any T	any N	M1

patients who were betel quid chewers are also alcohol drinkers and tobacco smokers.<sup>(4,5,8)</sup>

With regard to the anatomical localization of oral cavity cancers, approximately 30–40% of all cases occur in the tongue or in the buccal mucosa. Altogether, lesions at these sites account for approximately 70% of all oral cavity malignancies.<sup>(5,7,9)</sup>

#### Premalignant lesions carry a high risk to progress towards malignant transformation

Premalignant lesions of the head and neck – including oral leukoplakia, erythroplakia, squamous papilloma and submucous fibrosis – carry a high risk to progress towards malignant transformation. Oral leukoplakia is a whitish patch or plaque that cannot be characterized clinically or pathologically as any other disease. It originates from non-specific reactions of the epithelium as a consequence of various exogenous and endogenous stimuli. Submucous fibrosis is a disease that produces changes similar to those of scleroderma but is limited to oral tissue. It presents as a whitish yellow discoloration with a chronic, insidious biological course. Oral squamous papilloma, characterized by a warty appearance, is composed of papillary

and verrucous growths of benign epithelium and minor amounts of supporting connective tissue.

Studies have shown that between 1 and 18% of oral premalignant lesions will develop into oral cancer.<sup>(10)</sup> As regards the age distribution of patients with premalignant lesions, oral submucous fibrosis is predominant in young patients whereas leukoplakia is more commonly found in older individuals. Patients with premalignant lesions have a high risk of HNC development. In a study of 1458 patients with premalignant lesions, 3.02% developed clinical evidence of carcinoma over a mean follow-up period of 42.6 months.<sup>(11)</sup> Specifically, 1.87% of patients with dysplastic lesion and 3.55% of those with hyperkeratosis/epithelial hyperplasia progressed to malignant transformation.<sup>(11)</sup> In another study of 1046 patients with oral leukoplakia, the prevalence rate of carcinoma was 12.9%.<sup>(12)</sup> The relative risks for the presence of malignancy in leukoplakias on the tongue and floor of mouth with non-homogeneous appearance were 2.72- and 28.13-fold higher, respectively, compared with those on buccal mucosa with homogeneous surface.<sup>(12)</sup> The average age of patients with leukoplakia was lower in patients engaged in the oral habits of alcohol drinking, betel quid chewing and cigarette smoking compared with those without any oral habit.<sup>(12)</sup> These results

1079

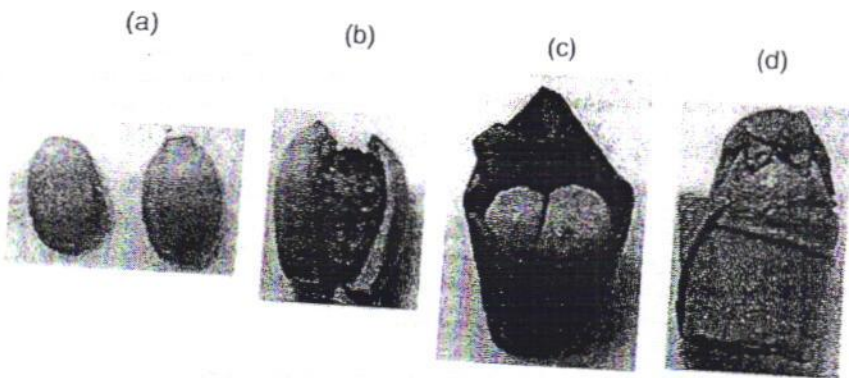

Fig. 5. Areca fruit and three major types of betel quid used in Taiwan, with (a) unripe areca fruit (b) Ching-a (c) Shuang-zi-sing and (d) Bao-hyeo.

clearly show that some leukoplakias may contain a malignant component. Although premalignant lesions with certain features are more prone to carcinomas, no clinical attributes may bring certitude. Therefore, all oral leukoplakias should be submitted to microscopic analysis before any definite treatment. Long-term follow-up of patients with premalignant oral lesions is highly recommended.<sup>(11,12)</sup>

#### Betel quid chewing, alcohol drinking and tobacco smoking can promote HNC

The oral habits of betel quid chewing, alcohol drinking and tobacco smoking have been documented as risk factors for HNC.<sup>(13-15)</sup> The 1985 International Agency for Research on Cancer (IARC) monograph on betel quid reported that there was sufficient evidence for carcinogenicity to humans for betel quid containing tobacco (Group 1 carcinogen), but reported inadequate evidence for carcinogenicity to humans for betel quid without tobacco (Group 3 carcinogen).<sup>(16)</sup> However, case-control studies from South-east Asia have reported that betel quid use, specifically without tobacco, may act as a risk factor for HNC.<sup>(17,18)</sup> Therefore, the recent 2003 IARC monograph declared chewing of betel quid, by itself, to be a Group 1 carcinogen and the areca nut to be, correspondingly, a Group 1 carcinogen.<sup>(19)</sup> The practice of betel quid chewing is widespread in Taiwan, especially for the indigenous people and blue-collar workers, with total estimated two million habitual users (10% of population).<sup>(20)</sup> Notably, the consumption of betel quid has gradually increased since 1970.<sup>(21)</sup> Aside from the psychoactive effect and facilitating social interactions between chewers, several phenomena may explain the increase of betel usage. In the 1970s, when Taiwan's economy was booming, to increase the labor-intensive productivity, bosses often handed out betel quids freely to the workers to enhance euphoric mood and reduce tension. During the 1980s, during the democracy movement, despite knowledge of the harmful effects, betel quid chewing became a symbol of Taiwanese identity and more people took up the habit. Gradually, people developed a tolerance to betel and demand increased. However, as evidence mounted identifying betel quid chewing as the major cause of oral cancer, cumulative antibetel actions were launched by the Taiwan government and betel consumption become steady after 2000.<sup>(21)</sup>

Risks of betel quid vary with the type of quid. Chewers using betel inflorescence in the quid are at highest risk, whereas those using betel leaves are at the lowest.<sup>(22)</sup> Unlike chewers from most countries in South-east Asia, which use mature betel fruit, the Taiwanese chewer commonly uses fresh, unripe betel fruit with slaked lime as an essential ingredient.<sup>(23,24)</sup> There are three major types of betel quid used in Taiwan, locally called 'Ching-a', 'Shuang-zi-sing' and 'Bao-hyeo' (Fig. 5). Ching-a is commonly used in urban areas. It is made by putting a piece of inflores-

cence of *Piper betle* Linnaeus with red slaked lime paste into slit-open unripe betel nut (Fig. 5b). Shuang-zi-sing is made by wrapping two pieces of half unripe betel nut and red slaked lime paste with a piece of betel leaf (Fig. 5c). Bao-hyeo is made by wrapping an unripe betel nut and white slaked lime paste with a piece of betel leaf (Fig. 5d). Tobacco is never added in any type of chewing quid. The habit of chewing tobacco alone or pipe smoking is rare in the general population of Taiwan. However, cigarette smoking is also common, especially with areca/betel quid chewers, but people with both chewing and smoking habits rarely simultaneously use.

The prevalence of oral precancerous lesions (leukoplakia, submucous fibrosis and verrucous lesions) has been associated with different life styles relating to quid chewing, tobacco smoking and alcohol drinking.<sup>(25)</sup> A population-based study of 320 individuals has shown that the odds ratio for chewing areca/betel quid and having at least one oral precancerous lesion was 8.21.<sup>(24)</sup> Reported odds ratios for oral leukoplakia in betel quid chewers and tobacco smokers were 17.4 and 3.2, respectively, in a case-control study of 435 subjects.<sup>(26)</sup> A dose-response effect for duration and amount of chewing habit on HNC risk was especially observed, with the prevalence of oral lesions increasing as the years of chewing or daily consumption increased.<sup>(25)</sup> Tobacco and betel quid may act synergistically as a carcinogen.<sup>(27)</sup> A hospital-based case-control study involving 307 participants has reported that betel chewing and smoking increase the risk of oral cancer to 28- and 18-fold, respectively. A cumulative effect from betel quid chewing, alcohol drinking and tobacco smoking has been observed, with a 123-fold increased risk of oral cancer when the three risk factors are present.<sup>(8)</sup> In modelling the effect of betel quid chewing on HNC risk, it has been shown that betel quid chewers had a lower median age of onset (approximately 6-12 years earlier) compared with non-chewers.<sup>(6)</sup> Betel quid chewing has also been associated with cancer prognosis in a dose- and time-dependent fashion. In a study of 378 HNC patients, the 5-year survival rate of chewers was significantly lower than that of non-chewers.<sup>(28)</sup> In contrast, no significant difference was seen in 5-year survival between smokers and non-smokers or between alcohol users and non-users.<sup>(28)</sup> Similarly, the risk of death has been reported to be 31.4-fold higher in heavy betel quid users (duration >30 years, daily consumption >30 quids) compared with those who chewed betel quid to a milder extent (duration <10 years, daily consumption <15 quids).<sup>(29)</sup>

#### Betel-quid-associated molecular pathology

The composition of betel quid differs geographically; the areca quid used in Taiwan contains areca nut, lime and *Piper betle* inflorescence.<sup>(23,24)</sup> *Piper betle* inflorescence contains high concentrations of hydroxychavicol and safrole, whereas arecoline, a major areca nut alkaloid, is considered to be the most important carcinogen in the areca nut. Areca nut extract (ANE)

1080  
2

is highly cytotoxic and genotoxic to cultured human oral mucosal epithelial cells and fibroblasts. Exposure of human keratinocytes to ANE results in apoptosis, generation of reactive oxygen species, genetic damage and micronuclei formation.<sup>(30)</sup> The same study has found that 24-h treatment with ANE induced mutations at the hypoxanthine phosphoribosyltransferase (HPRT) locus in human keratinocytes.<sup>(30)</sup> Increased intracellular levels of reactive oxygen species and 8-hydroxyguanosine in cells exposed to ANE have been also reported.<sup>(30)</sup>

Salivary concentration of arecoline during betel quid chewing has been detected to be in the millimolar concentration range.<sup>(31)</sup> Arecoline has been shown to induce structural chromosomal aberration, sister chromatid exchange and micronuclei formation in different cell types.<sup>(32,33)</sup> Studies in human oral cancer cells have shown that exposure to arecoline or ANE results in growth arrest in the late S and G2/M phases.<sup>(34)</sup> Moreover, it has been shown that arecoline induced a significant elevation of p21waf1 and a decline of cdc2 and cyclin B1 in gingival keratinocytes.<sup>(34)</sup>

Piper betel inflorescence, which contains safrole, is a unique ingredient of betel quid in Taiwan. Safrole-DNA adducts have been suggested to play an important role in oral carcinogenesis. Accordingly, a high frequency of safrole-like DNA adducts has been reported in betel-quid-associated oral squamous cell carcinomas and non-cancerous matched tissue, in contrast to the absence of such adducts in all of non-betel-associated oral cancers.<sup>(35)</sup>

Hydroxychavicol, a phenolic component of betel leaf, has been found in human saliva at a 4.6 mM concentration after betel quid chewing.<sup>(36)</sup> Hydroxychavicol may induce the formation of single-strand DNA breaks and 8-hydroxydeoxyguanosine – a marker of oxidative DNA damage – in cultured cells.<sup>(37,38)</sup> Moreover, COX-2 expression and PGE<sub>2</sub> production have been shown to be significantly enhanced by hydroxychavicol in human normal oral keratinocytes.<sup>(39)</sup> Another study has shown that hydroxychavicol has the capacity to modulate cigarette carcinogen benzo[a]pyrene-mediated toxic effects by induction of dihydrodiol dehydrogenase (DDH) and HPRT gene mutation.<sup>(40)</sup> A further report has provided evidence that alkaline saliva generated by chewing betel quid may play a role in cigarette-related nicotine-induced DNA damage and reactive oxygen species may be involved in generating this DNA damage.<sup>(41)</sup> These findings provide a molecular explanation for the synergistic effect of betel quid chewing and tobacco smoking in the development of HNC in Taiwan.

### Molecules changes during the process of head and neck carcinogenesis

Under normal physiological conditions, gene expression is highly regulated to maintain cell homeostasis. The process of carcinogenesis involves gain of oncogene activity and loss of tumor suppressor gene function. Differential expression of these critical genes and other genes controlled by them contributes to malignant transformation. The identification of these genes is essential for understanding HNC molecular carcinogenesis.

The entry and progression of a cell through the cell cycle is controlled by changes in the levels and activities of several cyclins, cyclin-dependent kinases (CDK) and their inhibitors. Disruption of the G1-S checkpoints leads to uncontrolled cell growth, resulting in the development of cancer. Immunohistochemical studies have shown that overexpression of cyclin A protein is associated with tumor progression and patient prognosis in oral squamous cell carcinoma.<sup>(42)</sup> Notably, overexpression of cyclin A is significantly associated with increased tumor size, advanced tumor and lymph node involvement. Similarly cyclin D1, which is required for transition from G1 to S phase, was found to be hyperexpressed in oral squamous cell carcinomas.

Specifically, tumors containing more cyclin D1-positive cells had significantly shorter survival rates than those of tumors containing a lower number of cyclin D1-positive cells.<sup>(43)</sup> An altered expression of the cdk inhibitor p27Kip1, which is capable of blocking cell cycle progression from the G1 to the S phase, has been reported in HNC specimens. A previous immunohistochemical study has shown that the loss of p27Kip1 protein expression is a common event and may play a crucial role in the pathogenesis of oral cancer in Taiwan.<sup>(44)</sup> It has been also observed that patients with low or absent p27Kip1 protein expression had poor prognosis.<sup>(44)</sup>

Besides cyclins and their inhibitors, recent studies have focused on the potential role played by telomerase in HNC. Telomerase expression has been shown to be closely associated with cellular immortality and cancer, probably because it maintains telomere length and chromosome stability. Studies have shown that cancer severity and prognosis correlate with the expression of telomerase.<sup>(3)</sup> MDM2 (murine double minute gene 2) overexpression has been also suggested to play a role in human tumorigenesis via inhibition of the p53 tumor suppressor protein. A high degree of MDM2 overexpression has been reported in oral squamous cell carcinomas in Taiwan, but no significant association was found between the MDM2 immunostaining and clinical staging or primary tumor status.<sup>(45)</sup>

Alterations of apoptotic signal transduction proteins, such as c-Jun, have been reported in HNC. c-Jun is unique in its ability to positively regulate cell proliferation through the repression of tumor suppressor gene expression and function.<sup>(46)</sup> A 3-fold increase in c-Jun expression has been described in oral mucosal fibroblasts after exposure to ANE or arecoline.<sup>(47)</sup> It has been also reported that 60% of oral cavity cancer patients in Taiwan has a positive c-Jun immunostaining that correlates with shorter overall survival rates.<sup>(48)</sup> Rac1, a member of the Ras superfamily of small guanosine triphosphatases (GTPases) that act as molecular switches to control cytoskeletal rearrangements and cell growth, has been found to be hyperexpressed in a high fraction of HNC.<sup>(49)</sup> The inhibitor of apoptosis (IAP) proteins, a family of antiapoptotic regulators that block cell death in response to diverse stimuli through interactions with inducers and effectors of apoptosis, have been found to be expressed in potentially malignant and malignant oral lesions, but not in normal oral mucosa.<sup>(50)</sup> Moreover, high levels of survivin – a recently identified protein that suppresses programmed cell death and regulates cell division – have emerged as an important indicator of poor prognosis in HNC.<sup>(50)</sup>

Cell adhesion molecules and cell surface receptors have been implicated in the pathogenesis of HNC in Taiwan. It was recently shown that expression of epidermal growth factor receptor (EGFR; c-erbB-1) and its family protein Her-2 (c-erbB-2) are increased in oral cancer by 3.5-fold and 1.5-fold, respectively.<sup>(51)</sup> EGFR hyperexpression has been found to be associated with clinical stage, extracapsular spread and poor prognosis.<sup>(51)</sup> Hepatocyte growth factor (HGF) (scatter factor) and its receptor, the c-met proto-oncogene product (c-met), have also been implicated in HNC progression.<sup>(52)</sup> Specifically, c-met expression was significantly associated with T status, N status and clinical staging of oral cancer, whereas the hepatocyte growth factor (HGF) in the tumor invasion front was significantly correlated with N status and clinical staging.<sup>(52)</sup>

CD44 is a transmembrane adhesion molecule postulated to play a role in tumor aggression. The overexpression of CD44 has been shown to be associated with metastasis and poor prognosis in several human malignancies, but the CD44 splice isoform CD44v7-8 has been shown to act as a tumor suppressor factor. Accordingly, a higher degree of CD44v7-8 staining has been associated with a better prognosis in HNC.<sup>(53)</sup> Desmoglein 3 (DSG3), a calcium-binding transmembrane glycoprotein component of desmosomes in epithelial cells, has been found to

1081  
A

be overexpressed in HNC specimens.<sup>(54)</sup> Notably, correlations were seen between DSG3 expression and T stage, N stage, overall stage, tumor depth and extracapsular spread.<sup>(54)</sup>

In recent years, advances in comprehensive genomic and proteomic technologies are providing researchers with an unprecedented opportunity for high-throughput molecular analysis of HNC. A recent proteomic study has identified a total of 41 proteins overexpressed in oral cancer, including alphaB-crystallin, tropomyosin 2, myosin light chain 1, heat shock protein 27, stratifin, thioredoxin-dependent peroxide reductase, flavin reductase, vimentin, rho GDP-dissociation inhibitor 2, glutathione S-transferase Pi and manganese superoxide dismutase.<sup>(55)</sup> Real-time quantitative reverse transcriptase-polymerase chain reaction (RT-PCR) was used to validate selected proteomic data, confirming that alphaB-crystallin, heat shock protein 27 and manganese superoxide dismutase are significantly overexpressed in this malignancy.<sup>(55)</sup> Using cDNA microarray analysis, Tsai and colleagues identified 84 genes dysregulated in oral cancer associated with betel quid chewing.<sup>(56)</sup> Four genes, including *caspase-1*, *STAT-1*, *COX-2* (up-regulated) and *pleiotrophin* (down-regulated), were validated by further analyses.<sup>(56)</sup> Other authors have used fluorescent differential display analysis to identify gene expression profiles of HNC.<sup>(57)</sup> As a result, NPM, CDK1, NDRG1, HMGCR, EF1A, NAC and DSG3 were found to be up-regulated in HNC, whereas CHES1 was down-regulated.<sup>(57)</sup> Hyperexpression of CDK1 and NDRG1 was also associated with poorly differentiated tumors. Expression of CDK1 and NDRG1, as well as of CDK1 and CHES1, was significantly correlated, suggesting that these genes share a very close regulatory relationship or interact synergistically in oncogenesis.<sup>(57)</sup>

Although the full significance of dysregulation of gene expression in HNC is not entirely known, these discoveries hold promise with respect to improved diagnosis and treatment. Notably, differential display screening initially identified DSG3 as overexpressed in HNC.<sup>(57)</sup> Further studies identified the same molecule as associated with disease severity.<sup>(54)</sup> Consistent with the clinical data, inhibition of DSG3 by RNA interference (RNAi) significantly reduced cell growth and colony formation in three HNC cell lines.<sup>(54)</sup> Moreover, an *in vivo* xenograft study showed that administration of DSG3-RNAi plasmid significantly inhibited tumor growth in mice.<sup>(54)</sup> These findings suggest that DSG3 may be a potential molecular target in the development of adjuvant therapy for HNC.

#### Mutations and polymorphisms associated with HNC in Taiwan

Single nucleotide polymorphisms (SNP), point mutations, deletions and deregulation of DNA methylation have been suggested to play a role in HNC carcinogenesis. Research considering genetic alterations jointly with environmental exposures could be relevant for a better understanding of HNC in the betel quid chewing area. Specifically, somatic mutations induced by betel quid or other environmental carcinogens may be involved in the tumorigenesis of this carcinoma. On the other hand, genetic polymorphism may play a significant role in person-to-person variability in cancer susceptibility, raising the intriguing possibility that some individuals could be predisposed to HNC development. However, there is shortage of literature regarding the association of SNP and betel quid chewing.

The tumor suppressor protein *p53* is a key molecule in regulating expression of genes that mediate cell cycle arrest, and nucleotide variations in the *p53* gene have been extensively studied in HNC. Loss of heterozygosity (LOH) affecting *p53* exon 4 has been found in 42–74% of tumor samples, whereas LOH at the *p53* intron 6 was detected in 50% of specimens in Taiwan.<sup>(58,59)</sup> Interestingly, 84.4% of patients informative for *p53*

gene exon 4 had a history of both habitual cigarette smoking and betel quid chewing.<sup>(51)</sup> The contribution of the *p53* Arg72Pro polymorphism in the development of HNC has been also investigated. A report has shown that the combined susceptible genotype homozygous Pro/Pro and heterozygous Arg/Pro was associated with a higher risk of HNC compared with the Arg/Arg genotype.<sup>(60)</sup> Previous studies have also screened the conserved midregions of the *p53* gene (exons 5–9) for mutations. Missense or nonsense mutations at codons 161, 175, 177, 222, 255, 266, 273, 277 and 282 were found in approximately 20% of oral cancers in Taiwan.<sup>(61,62)</sup> Therefore, the incidence of mutations in conserved exons of *p53* in the betel quid chewing area is significantly different from that reported (46%) for worldwide oral squamous cell carcinoma related primarily to tobacco consumption.<sup>(61,62)</sup>

The tumor suppressor *p16/MTS1* (*CDKN2*) gene, on chromosome 9p21, codes for a cyclin-dependent kinase inhibitor and is frequently inactivated in many human cancers. A study has examined the presence of mutations, deletions and the methylation status of *p16/MTS1* in oral cancer associated with betel quid chewing in Taiwanese patients.<sup>(63)</sup> The authors identified mutations in exon 2 and at the intron 1/exon 2 splice site that disrupted the encoded protein.<sup>(63)</sup> Several base transitions were identified, including codon 51 GTC<sup>Val</sup>→GCC<sup>Ala</sup>, codon 101 GGG<sup>Gly</sup>→GGA<sup>Gly</sup>, codon 102 GCG<sup>Ala</sup>→GTG<sup>Val</sup> and a nonsense mutation 80 CGA<sup>Arg</sup>→TGA that resulted in a premature stop codon.<sup>(63)</sup> Interestingly, methylation of the *p16/MTS1* promoter region occurred preferentially in carcinomas of the tongue (54%) compared with other sites (22%).<sup>(63)</sup>

Other authors have investigated the role of adenomatous polyposis coli (*APC*) tumor suppressor gene during oral carcinogenesis. This gene plays an important role in various cellular functions including regulation of beta-catenin levels, cell migration and adhesion and cell cycle control. Five missense mutations (codon 1352 GTT<sup>Val</sup>→GCT<sup>Ala</sup>, codon 1367 CAG<sup>Glu</sup>→CGG<sup>Arg</sup>, codon 1382 GTT<sup>Val</sup>→GCT<sup>Ala</sup>, codon 1402 GCC<sup>Ala</sup>→ACC<sup>Thr</sup> and codon 1652 TCC<sup>Ser</sup>→TTC<sup>Phe</sup>) and a single nucleotide deletion at codon 1593 resulting in a premature stop codon in the *APC* gene have been identified in HNC patients.<sup>(64)</sup> Notably, a significant correlation was observed between these mutations in the *APC* gene and the patients' tobacco/betel quid consumption.<sup>(64)</sup>

Genetic mutations or deletions in other cancer-related genes have been associated with susceptibility to HNC in the betel quid chewing area. A biallelic polymorphism – adenine (A) to guanine (G) transition at position +49 of exon 1 of the *CTLA4* (Cytotoxic T lymphocyte associated antigen 4) gene – has been associated with HNC. Specifically, the homozygous AA genotype was found to be associated with a lower age at onset and poor prognosis.<sup>(65)</sup> Genetic polymorphisms in the promoter region of the tumor necrosis factor- $\alpha$  (*TNF- $\alpha$* ) gene are involved in the regulation of expression levels and have been associated with various malignant conditions. Two polymorphisms in the promoter region of the *TNF- $\alpha$*  gene (–308 G/A and –238 G/A) have been investigated for their role in susceptibility to HNC.<sup>(66)</sup> Results revealed that the frequency of the –308 TNFG allele genotype was higher in patients with oral cancer, and that of TNFA/G was lower; additionally, the frequency of the –238 TNFG/A allele genotype was lower in the patient group.<sup>(66)</sup> Angiogenesis, the formation of new blood vessels from endothelial precursors, is a prerequisite for the growth and progression of solid malignancies, and the vascular endothelial growth factor (*VEGF*) gene has been investigated in relation to HNC. A study has shown that the distribution of *VEGF* 5'-UTR –460 polymorphism was significantly different between HNC patients and controls; specifically, carriage of the *VEGF* –460T allele was associated with HNC.<sup>(67)</sup> Moreover, known genetic polymorphisms for a number of detoxification enzymes (null genotype in either *GSTM1* or *GSTT1* genes, *CYP2E1* c1/c2 or c2/c2 genotype)

1082  
f

have been linked to HNC among individuals who did not chew betel quid.<sup>(68)</sup> In light of the possible contribution of factors associated with thrombosis and inflammation to carcinogenesis, the angiotensin-converting enzyme (ACE) gene insertion/deletion (I/D) polymorphism has been recently investigated in relation to the presence of oral precancerous lesions in Taiwanese subjects who chew betel quid.<sup>(69)</sup> Results showed that the DD genotype independently predicted the presence of oral premalignant lesions.<sup>(69)</sup> Finally, mutations in mitochondrial DNA (mtDNA) have been suggested to play an important role in the development of HNC. Specifically, a study has found that betel quid chewing significantly enhanced the accumulation of mtDNA deletions in human oral tissues.<sup>(70)</sup>

### Virus associated with head and neck cancer in Taiwan

Human papillomavirus (HPV), the causal agent of cervical cancer, has been suggested to play a role in the etiology of cancer of the oral cavity and oropharynx. More than 120 different types of HPV exist, with approximately 40 types associated with lesions of the genital tract.<sup>(71)</sup> The most important oncogenic types are HPV type 16 (HPV-16) and HPV-18.<sup>(72)</sup> In many advanced preneoplastic cervical lesions and most derived carcinomas, HPV genomes are found to be integrated into the host cell chromosomes.<sup>(73,74)</sup> Following integration, the early HPV oncoproteins E6 and E7 are responsible for the malignant phenotype, mainly through inactivation of tumor suppressor proteins such as p53 and pRB.<sup>(75,76)</sup>

Besides cervical cancer, HPV infections have been linked to several other malignancies, including HNC.<sup>(77,78)</sup> An epidemiologic

survey in Taiwan has shown that HPV16, HPV18, betel quid chewing and tobacco smoking were statistically significant risk factors for oral squamous cell carcinoma, whereas HPV6 and HPV11 were not.<sup>(79)</sup> Multivariate analysis identified HPV16 and betel quid chewing as independent predictors of oral cancer.<sup>(79)</sup> Another study has shown that the positive rates of all HPV types and of high-risk HPV types were significantly higher in oral cancer samples compared with normal mucosa.<sup>(80)</sup> Moreover, rates of HPV infections were significantly higher in non-oral habits-associated oral cancer samples.<sup>(80)</sup> In light of these findings, the authors concluded that HPV infections may play an oncogenic role in oral cancer patients without cancer-associated oral habits.<sup>(80)</sup>

### Concluding remarks

In Taiwan, HNC incidence and mortality has increased over the past two decades. During 2006, OSCC has become the sixth most common type of cancer in this country, and it is also the fourth most common type of cancer among men. It follows that this type of cancer wreaks a high social and personal cost. The high incidence of HNC in the Taiwanese population has been attributed to certain oral habits prevalent in this population (betel quid chewing, tobacco smoking and alcohol drinking), as well as to genetic factors. The study of molecular carcinogenesis in an endemic betel quid chewing area not only provides a useful means to improve our understanding of HNC pathology at the molecular level but may also allow specific targeting of advice and therapy to high-risk individuals (i.e. those with a high-risk genotype in a high-risk environment).

### References

- 1 Clayman GL, Lippman SM, Laramore GE, Hong WK. Head and neck cancer. In: Jolland JF, Frei E, Bast RC, Kufe DW, Morton DL, Weichselbaum RR, eds. *Cancer Medicine*, 4th edn, chapter 105. Philadelphia, USA: Williams & Wilkins 1997; 1645-710.
- 2 Control of oral cancer in developing countries. A WHO meeting. *Bull World Health Organ* 1984; **62**: 817-30.
- 3 Daftary DK, Murti PR, Bhonsle RR, Gupta PC, Mehta FS, Pindborg JJ. Risk factors and risk markers for oral cancers in high risk areas of the world. In: Johnson NW, ed. *Oral Cancer: Detection of Patients and Lesions at Risk*. Cambridge: Cambridge University Press, 1991; 29-63.
- 4 Liao CT, Chang JT, Wang HM *et al*. Telomerase as an independent prognostic factor in head and neck squamous cell carcinoma. *Head Neck* 2004; **26**: 504-12.
- 5 Liao CT, Chang JT, Wang HM *et al*. Analysis of risk factors predictive of local tumor control in oral cavity cancer. *Ann Surg Oncol* 2008; **15**: 915-22.
- 6 Su CC, Yang HF, Huang SJ, Lian Ie B. Distinctive features of oral cancer in Changhua County: high incidence, buccal mucosa preponderance, and a close relation to betel quid chewing habit. *J Formos Med Assoc* 2007; **106**: 225-33.
- 7 Chen YK, Huang HC, Lin LM, Lin CC. Primary oral squamous cell carcinoma: an analysis of 703 cases in southern Taiwan. *Oral Oncol* 1999; **35**: 173-9.
- 8 Liao CT, Kang CJ, Chang JT *et al*. Survival of second and multiple primary tumors in patients with oral cavity squamous cell carcinoma in the betel quid chewing area. *Oral Oncol* 2007; **43**: 811-19.
- 9 Ko YC, Huang YL, Lee CH, Chen MJ, Lin LM, Tsai CC. Betel quid chewing, cigarette smoking and alcohol consumption related to oral cancer in Taiwan. *J Oral Pathol Med* 1995; **24**: 450-3.
- 10 Reibel J. Prognosis of oral pre-malignant lesions: significance of clinical, histopathological, and molecular biological characteristics. *Crit Rev Oral Biol Med* 2003; **14**: 47-62.
- 11 Hsue SS, Wang WC, Chen CH, Lin CC, Chen YK, Lin LM. Malignant transformation in 1458 patients with potentially malignant oral mucosal disorders: a follow-up study based in a Taiwanese hospital. *J Oral Pathol Med* 2007; **36**: 25-9.
- 12 Lee JJ, Hung HC, Cheng SJ *et al*. Carcinoma and dysplasia in oral leukoplakias in Taiwan: prevalence and risk factors. *Oral Surg Oral Med Oral Pathol Oral Radiol Endod* 2006; **101**: 472-80.
- 13 Choi SY, Kahyo H. Effect of cigarette smoking and alcohol consumption in the aetiology of cancer of the oral cavity, pharynx and larynx. *Int J Epidemiol* 1991; **20**: 878-85.
- 14 Mashberg A, Boffetta P, Winkelman R, Garfinkel L. Tobacco smoking, alcohol drinking, and cancer of the oral cavity and oropharynx among U.S. veterans. *Cancer* 1993; **72**: 1369-75.
- 15 Menielle G, Luce D, Goldberg P, Leclerc A. Smoking, alcohol drinking, occupational exposures and social inequalities in hypopharyngeal and laryngeal cancer. *Int J Epidemiol* 2004; **33**: 799-806.
- 16 IARC. Betel-quid and areca-nut chewing. *IARC Monogr Eval Carcinog Risks Hum* 1985; **37**: 141-291.
- 17 Sankaranarayanan R, Duffy SW, Padmakumary G, Day NE, Krishan Nair M. Risk factors for cancer of the buccal and labial mucosa in Kerala, southern India. *J Epidemiol Community Health* 1990; **44**: 286-92.
- 18 Sankaranarayanan R, Duffy SW, Padmakumary G, Day NE, Padmanabhan TK. Tobacco chewing, alcohol and nasal snuff in cancer of the gingiva in Kerala, India. *Br J Cancer* 1989; **60**: 638-43.
- 19 IARC. Betel-quid and areca nut chewing and some related nitrosamines. *IARC Monogr Eval Carcinog Risks Hum* 2003; **85**: 11-18.
- 20 Ko YC, Chiang TA, Chang SJ, Hsieh SF. Prevalence of betel quid chewing habit in Taiwan and related sociodemographic factors. *J Oral Pathol Med* 1992; **21**: 261-4.
- 21 Wang A. Betel nut culture turns over a new leaf. *Taiwan Rev* 2008; **58** (2): (<http://taiwanreview.nat.gov.tw/>).
- 22 Lee KW, Kuo WR, Tsai SM *et al*. Different impact from betel quid, alcohol and cigarette: risk factors for pharyngeal and laryngeal cancer. *Int J Cancer* 2005; **117**: 831-6.
- 23 Yang YH, Chen CH, Chang JS, Lin CC, Cheng TC, Shieh TY. Incidence rates of oral cancer and oral pre-cancerous lesions in a 6-year follow-up study of a Taiwanese aboriginal community. *J Oral Pathol Med* 2005; **34**: 596-601.
- 24 Yang YH, Lee HY, Tung S, Shieh TY. Epidemiological survey of oral submucous fibrosis and leukoplakia in aborigines of Taiwan. *J Oral Pathol Med* 2001; **30**: 213-19.
- 25 Chung CH, Yang YH, Wang TY, Shieh TY, Warnakulasuriya S. Oral precancerous disorders associated with areca quid chewing, smoking, and alcohol drinking in southern Taiwan. *J Oral Pathol Med* 2005; **34**: 460-6.
- 26 Shiu MN, Chen TH, Chang SH, Hahn LJ. Risk factors for leukoplakia and malignant transformation to oral carcinoma: a leukoplakia cohort in Taiwan. *Br J Cancer* 2000; **82**: 1871-4.
- 27 Lee CH, Ko YC, Huang HL *et al*. The precancer risk of betel quid chewing, tobacco use and alcohol consumption in oral leukoplakia and oral submucous fibrosis in southern Taiwan. *Br J Cancer* 2003; **88**: 366-72.
- 28 Lo WL, Kao SY, Chi LY, Wong YK, Chang RC. Outcomes of oral squamous cell carcinoma in Taiwan after surgical therapy: factors affecting survival. *J Oral Maxillofac Surg* 2003; **61**: 751-8.

1083  
E

- 29 Lee JJ, Jeng JH, Wang HM *et al.* Univariate and multivariate analysis of prognostic significance of betel quid chewing in squamous cell carcinoma of buccal mucosa in Taiwan. *J Surg Oncol* 2005; **91**: 41-7.
- 30 Lai KC, Lee TC. Genetic damage in cultured human keratinocytes stressed by long-term exposure to areca nut extracts. *Mutat Res* 2006; **599**: 66-75.
- 31 Sundqvist K, Liu Y, Nair J, Bartsch H, Arvidson K, Grafstrom RC. Cytotoxic and genotoxic effects of areca nut-related compounds in cultured human buccal epithelial cells. *Cancer Res* 1989; **49**: 5294-8.
- 32 Jeng JH, Chang MC, Hahn LJ. Role of areca nut in betel quid-associated chemical carcinogenesis: current awareness and future perspectives. *Oral Oncol* 2001; **37**: 477-92.
- 33 Shirname LP, Menon MM, Nair J, Bhide SV. Correlation of mutagenicity and tumorigenicity of betel quid and its ingredients. *Nutr Cancer* 1983; **5**: 87-91.
- 34 Lee PH, Chang MC, Chang WH *et al.* Prolonged exposure to arecoline arrested human KB epithelial cell growth: regulatory mechanisms of cell cycle and apoptosis. *Toxicology* 2006; **220**: 81-9.
- 35 Chen CL, Chi CW, Chang KW, Liu TY. Saprole-like DNA adducts in oral tissue from oral cancer patients with a betel quid chewing history. *Carcinogenesis* 1999; **20**: 2331-4.
- 36 Wang CK, Hwang LS. Phenolic compounds of betel quid chewing juice. *Food Sci (in Chinese)* 1992; **20**: 458-71.
- 37 Lee-Chen SF, Chen CL, Ho LY *et al.* Role of oxidative DNA damage in hydroxychavicol-induced genotoxicity. *Mutagenesis* 1996; **11**: 519-23.
- 38 Chen CL, Chi CW, Liu TY. Enhanced hydroxychavicol-induced cytotoxic effects in glutathione-depleted HepG2 cells. *Cancer Lett* 2000; **155**: 29-35.
- 39 Tang DW, Lin SC, Chang KW, Chi CW, Chang CS, Liu TY. Elevated expression of cyclooxygenase (COX)-2 in oral squamous cell carcinoma - evidence for COX-2 induction by areca quid ingredients in oral keratinocytes. *J Oral Pathol Med* 2003; **32**: 522-9.
- 40 Tang DW, Chang KW, Chi CW, Liu TY. Hydroxychavicol modulates benzo[a]pyrene-induced genotoxicity through induction of dihydrodiol dehydrogenase. *Toxicol Lett* 2004; **152**: 235-43.
- 41 Wu HJ, Chi CW, Liu TY. Effects of pH on nicotine-induced DNA damage and oxidative stress. *J Toxicol Environ Health* 2005; **68**: 1511-23.
- 42 Chen HM, Yen-Ping KM, Lin KH, Lin CY, Chiang CP. Expression of cyclin A is related to progression of oral squamous cell carcinoma in Taiwan. *Oral Oncol* 2003; **39**: 476-82.
- 43 Kuo MY, Lin CY, Hahn LJ, Cheng SJ, Chiang CP. Expression of cyclin D1 is correlated with poor prognosis in patients with areca quid chewing-related oral squamous cell carcinomas in Taiwan. *J Oral Pathol Med* 1999; **28**: 165-9.
- 44 Kuo MY, Hsu HY, Kok SH *et al.* Prognostic role of p27 (Kip1) expression in oral squamous cell carcinoma in Taiwan. *Oral Oncol* 2002; **38**: 172-8.
- 45 Huang JS, Ho TJ, Chiang CP, Kok SH, Kuo YS, Kuo MY. MDM2 expression in areca quid chewing-associated oral squamous cell carcinomas in Taiwan. *J Oral Pathol Med* 2001; **30**: 53-8.
- 46 Shaulian E, Karin M. AP-1 as a regulator of cell life and death. *Nat Cell Biol* 2002; **4**: E131-6.
- 47 Ho TJ, Chiang CP, Hong CY, Kok SH, Kuo YS, Yen-Ping Kuo M. Induction of the c-jun protooncogene expression by areca nut extract and arecoline on oral mucosal fibroblasts. *Oral Oncol* 2000; **36**: 432-6.
- 48 Kuo RC, Lin CY, Kuo MY. Prognostic role of c-Jun activation in patients with areca quid chewing-related oral squamous cell carcinomas in Taiwan. *J Formos Med Assoc* 2006; **105**: 229-34.
- 49 Liu SY, Yen CY, Yang SC, Chiang WF, Chang KW. Overexpression of Rac-1 small GTPase binding protein in oral squamous cell carcinoma. *J Oral Maxillofac Surg* 2004; **62**: 702-7.
- 50 Lin CY, Hung HC, Kuo RC, Chiang CP, Kuo MY. Survivin expression predicts poorer prognosis in patients with areca quid chewing-related oral squamous cell carcinoma in Taiwan. *Oral Oncol* 2005; **41**: 645-54.
- 51 Chen IH, Chang JT, Liao CT, Wang HM, Hsieh LL, Cheng AJ. Prognostic significance of EGFR and Her-2 in oral cavity cancer in betel quid prevalent area cancer prognosis. *Br J Cancer* 2003; **89**: 681-6.
- 52 Chen YS, Wang JT, Chang YF *et al.* Expression of hepatocyte growth factor and c-met protein is significantly associated with the progression of oral squamous cell carcinoma in Taiwan. *J Oral Pathol Med* 2004; **33**: 209-17.
- 53 Kuo MY, Cheng SJ, Chen HM, Kok SH, Hahn LJ, Chiang CP. Expression of CD44s, CD44v5, CD44v6 and CD44v7-8 in betel quid chewing-associated oral premalignant lesions and squamous cell carcinomas in Taiwan. *J Oral Pathol Med* 1998; **27**: 428-33.
- 54 Chen YJ, Chang JT, Lee L *et al.* DSG3 is overexpressed in head neck cancer and is a potential molecular target for inhibition of oncogenesis. *Oncogene* 2007; **26**: 467-76.
- 55 Lo WY, Tsai MH, Tsai Y *et al.* Identification of over-expressed proteins in oral squamous cell carcinoma (OSCC) patients by clinical proteomic analysis. *Clin Chim Acta* 2007; **376**: 101-7.
- 56 Tsai WC, Tsai ST, Ko JY *et al.* The mRNA profile of genes in betel quid chewing oral cancer patients. *Oral Oncol* 2004; **40**: 418-26.
- 57 Chang JT, Wang HM, Chang KW *et al.* Identification of differentially expressed genes in oral squamous cell carcinoma (OSCC): overexpression of NPM, CDK1 and NDRG1 and underexpression of CHES1. *Int J Cancer* 2005; **114**: 942-9.
- 58 Hsieh LL, Huang TH, Chen IH *et al.* p53 polymorphisms associated with mutations in and loss of heterozygosity of the p53 gene in male oral squamous cell carcinomas in Taiwan. *Br J Cancer* 2005; **92**: 30-5.
- 59 Huang MF, Chang YC, Liao PS, Huang TH, Tsay CH, Chou MY. Loss of heterozygosity of p53 gene of oral cancer detected by exfoliative cytology. *Oral Oncol* 1999; **35**: 296-301.
- 60 Twu CW, Jiang RS, Shu CH, Lin JC. Association of p53 codon 72 polymorphism with risk of hypopharyngeal squamous cell carcinoma in Taiwan. *J Formos Med Assoc* 2006; **105**: 99-104.
- 61 Wong YK, Liu TY, Chang KW *et al.* p53 alterations in betel quid- and tobacco-associated oral squamous cell carcinomas from Taiwan. *J Oral Pathol Med* 1998; **27**: 243-8.
- 62 Kuo MY, Huang JS, Hsu HC *et al.* Infrequent p53 mutations in patients with areca quid chewing-associated oral squamous cell carcinomas in Taiwan. *J Oral Pathol Med* 1999; **28**: 221-5.
- 63 Lin SC, Chang KW, Chang CS *et al.* Alterations of p16/MTS1 gene in oral squamous cell carcinomas from Taiwanese. *J Oral Pathol Med* 2000; **29**: 159-66.
- 64 Kok SH, Lee JJ, Hsu HC, Chiang CP, Kuo YS, Kuo MY. Mutations of the adenomatous polyposis coli gene in areca quid and tobacco-associated oral squamous cell carcinomas in Taiwan. *J Oral Pathol Med* 2002; **31**: 395-401.
- 65 Wong YK, Chang KW, Cheng CY, Liu CJ. Association of CTLA-4 gene polymorphism with oral squamous cell carcinoma. *J Oral Pathol Med* 2006; **35**: 51-4.
- 66 Liu CJ, Wong YK, Chang KW, Chang HC, Liu HF, Lee YJ. Tumor necrosis factor-alpha promoter polymorphism is associated with susceptibility to oral squamous cell carcinoma. *J Oral Pathol Med* 2005; **34**: 608-12.
- 67 Ku KT, Wan L, Peng HC, Tsai MH, Tsai CH, Tsai FJ. Vascular endothelial growth factor gene-460 C/T polymorphism is a biomarker for oral cancer. *Oral Oncol* 2005; **41**: 497-502.
- 68 Hung HC, Chuang J, Chien YC *et al.* Genetic polymorphisms of CYP2E1, GSTM1, and GSTT1: environmental factors and risk of oral cancer. *Cancer Epidemiol Biomarkers Prev* 1997; **6**: 901-5.
- 69 Chung FM, Yang YH, Chen CH, Lin CC, Shieh TY. Angiotensin-converting enzyme gene insertion/deletion polymorphism is associated with risk of oral precancerous lesion in betel quid chewers. *Br J Cancer* 2005; **93**: 602-6.
- 70 Lee HC, Yin PH, Yu TN *et al.* Accumulation of mitochondrial DNA deletions in human oral tissues - effects of betel quid chewing and oral cancer. *Mutat Res* 2001; **493**: 67-74.
- 71 Remmerbach TW, Brinckmann UG, Hemprich A, Chekol M, Kuhndel K, Liebert UG. PCR detection of human papillomavirus of the mucosa. comparison between MY09/11 and GP5/6' primer sets. *J Clin Virol* 2004; **30**: 302-8.
- 72 Bosch FX, Manos MM, Munoz N *et al.* Prevalence of human papillomavirus in cervical cancer: a worldwide perspective. International biological study on cervical cancer (IBSCC) Study Group. *J Natl Cancer Inst* 1995; **87**: 796-802.
- 73 Durst M, Croce CM, Gissmann L, Schwarz E, Huebner K. Papillomavirus sequences integrate near cellular oncogenes in some cervical carcinomas. *Proc Natl Acad Sci* 1987; **84**: 1070-4.
- 74 Riou GF, Bourhis J, Le MG. The c-myc proto-oncogene in invasive carcinomas of the uterine cervix: clinical relevance of overexpression in early stages of the cancer. *Anticancer Res* 1990; **10**: 1225-31.
- 75 Dyson N, Howley PM, Munger K, Harlow E. The human papilloma virus-16, E7 oncoprotein is able to bind to the retinoblastoma gene product. *Science* 1989; **243**: 934-7.
- 76 Scheffner M, Werness BA, Huibregtse JM, Levine AJ, Howley PM. The E6 oncoprotein encoded by human papillomavirus types 16 and 18 promotes the degradation of p53. *Cell* 1990; **63**: 1129-36.
- 77 Brandwein M, Zeitlin J, Nuovo GJ *et al.* HPV detection using 'hot start' polymerase chain reaction in patients with oral cancer: a clinicopathological study of 64 patients. *Mod Pathol* 1994; **7**: 720-7.
- 78 Young SK, Min KW. In situ DNA hybridization analysis of oral papillomas, leukoplakias, and carcinomas for human papillomavirus. *Oral Surg Oral Med Oral Pathol* 1991; **71**: 726-9.
- 79 Chen PC, Kuo C, Pan CC, Chou MY. Risk of oral cancer associated with human papillomavirus infection, betel quid chewing, and cigarette smoking in Taiwan - an integrated molecular and epidemiological study of 58 cases. *J Oral Pathol Med* 2002; **31**: 317-22.
- 80 Chang JY, Lin MC, Chiang CP. High-risk human papillomaviruses may have an important role in non-oral habits-associated oral squamous cell carcinomas in Taiwan. *Am J Clin Pathol* 2003; **120**: 909-16.

1084  
f

## Betel quid not containing tobacco and oral cancer: A report on a case-control study in Papua New Guinea and a meta-analysis of current evidence

Steven J. Thomas<sup>1\*</sup>, Christopher J. Bain<sup>2</sup>, Diana Battistutta<sup>3</sup>, Andrew R. Ness<sup>4</sup>, Darius Paissat<sup>5</sup> and Robert MacLennan<sup>6</sup>

<sup>1</sup>Division of Maxillofacial Surgery, University of Bristol, UK

<sup>2</sup>School of Population Health, University of Queensland, Brisbane, Australia

<sup>3</sup>School of Public Health, Queensland University of Technology, Brisbane, Australia

<sup>4</sup>Department of Social Medicine, University of Bristol, UK

<sup>5</sup>Department of Health, Kavieng, Papua New Guinea

<sup>6</sup>Population and Clinical Sciences, Queensland Institute of Medical Research, Brisbane, Australia

Smoking and betel quid chewing are associated with increased risk of oral cancer but few studies have reported on associations in populations where betel quid does not contain tobacco. We conducted a case-control study in Papua New Guinea and a systematic review. Our case-control study recruited 143 cases with oral cancer and 477 controls. We collected information on smoking and betel quid chewing. Current smoking was associated with an increased risk of oral cancer with an adjusted odds ratio (OR) for daily smokers of 2.63 (95% confidence intervals (95% CI) 1.32, 5.22) and amongst heaviest smokers of 4.63 (95% CI 2.07, 10.36) compared to never-smokers. Betel chewing was associated with increased risk of oral cancer with an adjusted OR for current chewers of 2.03 (95% CI 1.01, 4.09) and in the heaviest chewers of 2.47 (95% CI 1.13, 5.40) compared to nonchewers. The OR in those who both smoked tobacco and chewed betel quid was 4.85 (95% CI 1.10, 22.25), relative to those who neither smoked nor chewed. The systematic review identified 10 previous studies that examined risk of oral cancer associated with betel quid chewing that controlled for smoking in populations where betel quid did not contain tobacco. In studies that reported results for non-smokers the combined OR was 2.14 (95% CI 1.06, 4.32) in betel quid chewers and in studies that adjusted for smoking the combined OR was 3.50 (95% CI 2.16, 5.65) in betel quid chewers. Preventive efforts should discourage betel quid chewing as well as smoking.

© 2006 Wiley-Liss, Inc.

**Key words:** oral cancer; betel quid; case-control study; meta-analysis

Oral cancer is not uncommon and is an important cause of morbidity and mortality with 267,000 cases reported globally in 2000, 2/3 of them in men. There are marked international variations in reported incidence. Melanesia has the highest incidence in the world (36.3 per 10<sup>5</sup> in men and 23.6 per 10<sup>5</sup> in women) and oral carcinoma is the most common cancer in Papua New Guinea (PNG). Rates are also high in South Asia (13.0 per 10<sup>5</sup> in men and 8.6 per 10<sup>5</sup> in women).<sup>1</sup>

Smoking has been consistently associated with increased risk of oral cancer but smoking patterns do not adequately explain geographical variation of this cancer.<sup>1</sup> One factor that may explain these variations in disease risk is the chewing of betel quid. Betel quid constituents vary across cultures, but betel quid generally consists of Areca nut, part of the Piper betle plant (inflorescence, leaf or stem) and slaked lime (either as a powder or paste) with some populations including tobacco and other spices.<sup>2</sup> Several lines of evidence support the suggestion that the chewing of betel quid increases the risk of oral cancer. Betel quid has been shown to contain various carcinogens<sup>2</sup> and has been shown to be carcinogenic in animal models; areas where chewing of betel quid is common have higher rates of oral cancer and some case-control studies of oral cancer have reported increased risk in those who chew betel quid. For these reasons the International Agency for Research on Cancer decided that betel quid should be classified as a human carcinogen. But as betel quid in many countries contains tobacco and the chewing of betel quid is often associated with smoking, few studies have been able to estimate the role of betel quid as an

independent risk factor for oral cancer reliably, and only one has reported a dose-response.<sup>2,3</sup>

To clarify the situation we report a large case-control study in PNG where betel quid use is common, does not contain tobacco, and where smoking and betel quid exposure have been accurately recorded. In addition, we report and extend the existing literature by systematically reviewing case-control studies estimating the risk of oral cancer among people chewing betel quid that does not contain tobacco.

### Material and methods

This case-control study was conducted in Papua New Guinea (PNG) from January 1985 to July 1987. Cases were hospitalised with oral cancer and controls were hospital controls either admitted or related to someone admitted to the same hospital. Information on exposures was collected using an interviewer-administered questionnaire.

### Case selection

Cases had a first diagnosis of clinically apparent oral squamous cell carcinoma diagnosed by a doctor within 3 months of interview. They were identified at 6 hospitals serving 6 provinces with high rates of oral cancer. Approval for the project was sought from the medical superintendents of participating hospitals and permission to approach patients was sought from the treating doctor. Hospitals were contacted every fortnight by telephone and asked to provide the names and details of any possible cases admitted. Hospitals were visited by the research team every 3 months and cases were interviewed in hospital. Following an explanation of the scope, aims and purpose of the study, all eligible cases who were approached agreed to participate. At each visit the local clinicians were approached to see if any possible cases had been missed: none were identified.

### Control selection

Controls were people with an unrelated condition and no evidence of oral cancer or precancer, recently admitted to the same hospital as the index case. Towards the end of the study, guardians of these inpatients were also recruited if suitable patient controls were not available. Controls were recruited at visits to the hospitals over the course of the study, and were selected to have a similar

Grant sponsors: The study was funded by the World Health Organization via the Western Pacific Regional Office. Steven J. Thomas was supported by the National Health and Medical Research Council of Australia.

\*Correspondence to: University of Bristol, Lower Maudlin Street, Bristol, UK. Fax: +44-117-9252603.

E-mail: Steve.Thomas@Bristol.ac.uk

Received 14 March 2006; Accepted 22 June 2006

DOI 10.1002/ijc.22304

Published online 12 December 2006 in Wiley InterScience (www.interscience.wiley.com).



Publication of the International Union Against Cancer

1985  
R

distribution of age, sex and geographical location as the cases with a case-control ratio of about 1:3. The controls were approached in a similar manner to the cases and none refused to participate.

#### Interview methodology

Our study was conducted among a predominantly preliterate population (*i.e.* a culture not having a written language) with some particular methodological challenges in assessing duration and frequency of exposures. All subjects were interviewed by trained investigators fluent in Melanesian Pidgin, trained in a standard manner using a detailed instruction manual and monitored using tape recordings of the interviews. The timing of key events, such as the Second World War, was used to estimate age of the participants and as milestones to judge duration of exposure. To obtain frequency data on smoking and betel quid chewing, each person was first asked about their daily activities from waking until going to sleep. A typical day was divided into 24-hourly periods and then the interviewee was asked whether they chewed betel quid or smoked during this period. The history of chewing betel quid and smoking documented the specific components of the quid or type of tobacco in Melanesian Pidgin and the local language (*Tok Ples*) along with duration of use. The subjects were also asked whether they had ever been to school, whether they had a job that paid money and recorded whether they lived in an urban or rural setting.

#### Exposure data

Age was estimated within 5-year age groups with those aged below 40 years placed into a single category. Urban and rural residence was classified according to census division of residence. Those residing in the same census division as the provincial administrative centre were classified as urban; otherwise they were classified as rural. The reference group for all analyses was never smokers or never chewers unless the numbers in this group were too small, in which case it was expanded to include exsmokers or exchewers. Exsmokers or exchewers were smokers or chewers who had stopped for more than one year prior to the interview. Occasional smokers or chewers were those who reported smoking or chewing weekly or less often. Current daily smokers and chewers were people who still smoked or chewed daily or had been daily smokers or chewers within 1 year of the interview. Current smokers and chewers were split into 3 categories according to frequency of use and daily smokers of different types of tobacco were identified. Lifetime tobacco exposure was calculated as the product of daily frequency and duration of smoking and then the combined distribution was dichotomised for analysis. To provide a summary estimate of tobacco exposure from the different types of tobacco smoked throughout a subject's lifetime, total tar exposure was computed using frequency and duration of use for each tobacco and the estimated tar content of each type. The lifetime tar consumption was grouped into thirds based on the joint distribution of cases and controls.

#### Statistical methods

Unconditional multiple logistic regression was used to estimate odds ratios (ORs), and 95% confidence intervals (CIs) for the association between smoking and betel quid chewing, and to adjust for the effects of confounding variables. Unadjusted ORs, and ORs adjusted for age, sex, province, urban or rural residence, education and income and either smoking or betel chewing were estimated.

#### Systematic review and meta-analysis

Studies were located by searching MEDLINE, (from inception to January 2006), and the reference lists of relevant texts and reviews. A hierarchical literature search in MEDLINE used the following National Library of Medicine MeSH terms (Medical Subject Headings): 'Oral Neoplasms', 'Mouth', 'Betel' and 'Areca'. The additional keywords oral, oropharynx and cancer or carcinoma were also used in MEDLINE (truncated where necessary). Eligible studies were case-control studies of oral squamous cell carcinoma that had documented exposure to betel quid in populations where

betel quid did not contain tobacco. To identify potentially eligible studies the title and abstract of each study identified by the literature search was assessed. Full papers of potentially relevant studies were reviewed. Data extracted included numbers of cases and controls who were and were not exposed to betel quid without tobacco, evidence for a dose-response with betel quid chewing without tobacco, exposure to tobacco smoke, adjustment for tobacco smoking in the analysis, year of publication, country and sample size.

We used inverse-variance weighted fixed-effect meta-analysis, and DerSimonian and Laird random-effects meta-analyses<sup>4</sup> to derive summary OR in nonsmokers who chewed betel quid and for betel quid chewing after adjustment for smoking. Between-study heterogeneity was assessed using  $I^2$  statistics.<sup>5</sup> Stata version 8.2 was used for all analyses.

#### Results

A total of 620 subjects were recruited into the study: 143 cases (102 men) and 477 controls (342 men). The distribution of oral cancer cases and controls by age, sex, province, urban rural status, education and income are summarised in Table 1. Cases were less likely to reside in an urban area and less likely to have been to school but were similar in terms of having a job that paid money.

Most people had smoked tobacco (91% of cases and 82% of controls) and nearly everyone had chewed betel quid (99% of cases and 98% of controls). The majority of people were current smokers (78% of cases and 62% of controls) and current betel quid chewers (87% of cases and 79% of controls). Current smoking was nearly twice as common among male controls (72%) as females (35%), whereas the percentage reporting current betel quid chewing was similar in male (80%) and female (75%) controls.

The risks of oral cancer associated with smoking are summarised in Table 2. The risk of oral cancer was elevated in all categories of smoking exposure. Relative to nonsmokers, the risk was highest in current smokers and lower but still elevated in exsmokers. There was a dose-response relationship with both current daily tobacco consumption and lifetime exposure to tobacco smoke ( $p < 0.001$ ). Various types of tobacco were smoked. Locally and commercially grown air-dried 'Black' tobacco (*Brus or Stik*) was most commonly smoked while commercial flue-cured machine rolled 'Blond'

TABLE 1 - CHARACTERISTICS OF CASES AND CONTROLS BY AGE, SEX, PROVINCE, RESIDENCE, EDUCATION AND INCOME

Factors and subgroups	Cases		Controls	
	No	%	No	%
Total	143	100	477	100
Age in years				
<40	17	11.9	76	15.9
40-49	37	25.9	138	29.0
50-59	47	32.9	147	30.8
60-70	42	29.4	116	24.3
Sex				
Male	102	71.3	342	71.7
Female	41	28.7	135	28.3
Province				
New Ireland	33	23.1	94	19.7
East New Britain	15	10.5	64	13.4
Morobe	19	13.3	64	13.4
Madang	31	21.0	98	20.5
East Sepik	26	18.2	70	14.7
Milne Bay	20	14.0	87	18.2
Residence				
Urban	18	12.6	107	22.4
Rural	125	87.4	370	77.6
Education				
Yes	74	51.7	289	60.6
No	69	48.3	188	39.4
Income				
Yes	53	37.1	172	36.1
No	90	62.9	305	63.9

1086  
B

TABLE II - ODDS RATIO OF ORAL CANCER ASSOCIATED WITH TOBACCO SMOKING AND BETEL QUID CHEWING

Risk factors and subgroups	Cases (n)	Controls (n)	OR <sup>1</sup>	95%	OR <sup>2</sup>	95% CI
Tobacco smoking						
Never smoked	13	86	1.00		1.00	
Ever smoked	130	391	2.20	1.20, 4.04	2.19	1.12, 4.30
Exsmoker	12	45	1.76	0.75, 4.12	1.74	0.70, 4.33
Current occasional smoker	7	52	0.89	0.34, 2.32	0.88	0.32, 2.42
Current daily smoker	111	294	2.50	1.35, 4.61	2.63	1.32, 5.22
Smoking frequency						
Never	13	86	1.00		1.00	
1-14	30	106	1.87	0.93, 3.77	2.14	0.98, 4.67
15-21	31	97	2.11	1.05, 4.26	2.42	1.09, 5.35
22 or more	50	91	3.63	1.86, 5.21	4.63	2.07, 10.36
Lifetime exposure						
Never	13	86	1.00		1.00	
38-540 tobacco years	47	153	2.03	1.05, 3.93	2.47	1.18, 5.17
550-1595 tobacco years	64	141	3.00	1.58, 5.72	3.38	1.55, 7.37
Tobacco type (used daily)						
Never	13	86	1.00		1.00	
Air-cured 'Black' tobacco	93	232	2.65	1.41, 4.98	3.07	1.49, 6.03
Flue-cured 'Blond' tobacco	7	31	1.49	0.55, 4.09	1.82	0.64, 5.21
Both 'Black' and 'Blond' tobacco	11	31	2.35	0.95, 5.78	2.81	1.04, 7.60
Lifetime tar						
Nil	13	86	1.00		1.00	
Low	31	143	1.43	0.72, 2.86	1.56	0.74, 3.27
Medium	41	131	2.07	1.06, 4.05	2.36	1.12, 4.96
High	58	117	3.28	1.71, 6.31	3.49	1.62, 7.55
Betel quid chewing						
Never chewed	2	9	1.00		1.00	
Ever chewed	141	468	1.36	0.28, 6.35	1.10	0.22, 5.51
Exchewer	9	56	0.72	0.13, 3.90	0.57	0.10, 3.28
Current occasional chewer	8	37	0.97	0.18, 5.39	0.98	0.17, 5.74
Current daily chewer	124	375	1.49	0.32, 6.98	1.29	0.25, 6.51
Chewing frequency						
Nonchewer <sup>3</sup>	11	65	1.00		1.00	
Current chewer	132	412	1.89	0.97, 3.69	2.03	1.01, 4.09
Occasional	8	37	1.28	0.47, 3.46	1.57	0.56, 4.36
Low	28	122	1.36	0.63, 2.90	1.73	0.78, 3.84
Medium	47	141	1.97	0.96, 4.04	2.10	0.98, 4.47
High	49	112	2.59	1.26, 5.32	2.47	1.13, 5.40

<sup>1</sup>Odds ratios unadjusted. -<sup>2</sup>Odds ratios adjusted for age, sex, province, rural *cf* urban residence, income, education and frequency of betel quid chewing for smoking variables or frequency of smoking for chewing variables. -<sup>3</sup>Never and exchewers.

tobacco cigarettes were the tobacco type least often smoked. Only *Brus* varied in the way it was smoked usually either wrapped in newspaper or banana or tobacco leaf and less frequently smoked in a pipe. The risk of oral cancer increased regardless of the type of tobacco smoked or the method of smoking. Although the point estimate of risk was higher with 'Black' tobacco than 'Blond' CIs overlap. When different types of tobacco were combined to estimate lifetime tar exposure there was a linear dose-response relationship with risk of oral cancer ( $p < 0.001$ ). These associations were essentially unaltered after adjustment for potential confounders and adjustment for betel quid chewing.

Betel quids in this population did not contain tobacco and were unwrapped. The constituent areca nut, slaked lime and the inflorescence of the piper betel plant (the flower stalk of the plant) were placed separately in the mouth. The nut was chewed first, (the pericarp was sometimes included if the youngest *kulau* nuts were chewed). Powdered slaked lime was then repeatedly added to the mouth. Most people used a piper betel inflorescence, which was also chewed, to add the lime while others added lime using a wooden spatula. If a stick or spatula was used, the inflorescence or leaf of the piper betel was still chewed. The quid when chewed was intensely sialogenic and turned bright red. It was usually chewed for about 15 min and expectorated when its flavour diminished, although around a quarter of cases and controls reported swallowing the remnants and around twenty percent reported sleeping with the quid in their mouth on occasion. Only 2 cases and 1 control reported that they did not usually add lime.

The risks of oral cancer associated with betel quid chewing are summarised in Table II. Risk of oral cancer was higher in current daily betel quid chewers. To explore the association with dose of betel quid the never and exchewers were combined to create a reference category of nonchewers. There was statistical evidence of a dose-response association with betel quid consumption ( $p = 0.016$ ). These associations were essentially unaltered after adjustment for potential confounders and adjustment for smoking.

The risk of oral cancer with smoking and betel quid chewing are compared in smokers and nonsmokers and in chewers and nonchewers in Table III. The risk was higher in smokers and in betel chewers and highest in people who smoked tobacco and chewed betel quid when compared to people who did neither.

#### Systematic review and meta-analysis

Fourteen case-control studies were identified<sup>6-19</sup> that examined risk of oral cancer associated with chewing betel quid in populations where betel quid did not contain tobacco. Four were excluded because they did not report on nonsmokers or did not adjust for tobacco smoking in the analysis.<sup>6-9</sup> Therefore, 10 studies were included in the review together with the results of the present study.<sup>10-19</sup> These provided a total of 367 cases of oral cancer in people who were nonsmokers and 2,123 cases of oral cancer in studies in which smoking was adjusted for in the analysis.

1087  
R

Table IV shows characteristics of the studies including numbers of cases and controls exposure to betel quid without tobacco and adjustment for tobacco smoking. The majority of studies were hospital based. In one study, cases were identified from a population cancer registry<sup>10</sup> and controls were selected from the same population. Three other studies used population-based controls.

The proportion of oral cancer cases exposed to betel quid without tobacco ranged from 11 to 92% and from 3 to 86% in controls. Five studies, including the present one, reported on betel quid without tobacco chewing in nonsmokers, potential confounding factors were considered in 2 of these studies. Eight studies including the present one reported effect estimates adjusted for smoking amongst other potential confounders. All 11 studies reported dichotomous outcomes, 3 reporting never *versus* ever and the remaining studies *yes versus no*.

Meta-analysis stratified by tobacco smoking (Table IV, Fig. 1) shows an increased risk of oral cancer when exposed to betel quid without tobacco when the person was not a current smoker (random-effects summary OR 2.14, 95% CI 1.06, 4.32). There was evidence of between-study heterogeneity in these effects ( $I^2 = 77\%$ ,  $p = 0.002$ ). The risk of oral cancer was increased among chewers of betel quid without tobacco after adjusting for tobacco smoking (random-effects summary OR 3.50, 95% CI 2.16, 5.65) with evidence of between-study heterogeneity in these effects ( $I^2 = 70.6\%$ ,  $p = 0.001$ ).

Only 2 studies, Lu et al.<sup>18</sup> and the present study, had reported a dose-response. Both studies demonstrated an increased risk with exposure to betel quid after adjusting for the effect of smoking.

TABLE III - ODDS RATIOS FOR ORAL CANCER ACCORDING TO BETEL CHEWING AND SMOKING AMONG CURRENT DAILY CHEWERS AND SMOKERS

Current daily smoking		Current daily betel chewing	
		No <sup>1</sup>	Yes
No <sup>2</sup>	OR <sup>3</sup> (95% CI)	1.00 <sup>4</sup>	1.76 (0.35, 8.92)
	Cases/Controls	2, 20	11, 66
Yes	OR <sup>3</sup> (95% CI)	1.81 (0.27, 10.89)	4.85 (1.10, 22.25)
	Cases/controls	4, 22	107, 272

<sup>1</sup>Nonbetel quid chewer; this includes never chewers and exchewers. -<sup>2</sup>Nonsmoker; never-smokers. -<sup>3</sup>Referent category. -<sup>4</sup>ORs adjusted for age, sex, province, education, urban *cf* rural residence and income.

TABLE IV - CASE-CONTROL STUDIES ASSESSING RISK OF ORAL CANCER AMONG CHEWERS OF BETEL QUID WITHOUT TOBACCO. CHARACTERISTICS AND ODDS RATIOS (OR) IN STUDIES OF NONSMOKERS AND THOSE ADJUSTED FOR SMOKING

Smoking status Year, Country	Author	Controls	Number of cases (% chewers)	Number of controls (% chewers)	Betel quid chewing	Adjusted	OR	95% CI
Nonsmokers								
1962, India	Chandra	Hsp	181 (25)	326 (22)	Yes/no	No	1.3	0.8, 1.9
1966, India, SL	Hirayama	Pop	40 (33)	142 (28)	Yes/no	No	1.2	0.6, 2.6
1976, Pakistan	Jafarey	Pop	128 (31)	190 (6)	Yes/no	No	3.6	2.4, 5.3
1995, Taiwan	Ko	Hsp	5 (60)	51 (4)	Yes/no	Yes <sup>1</sup>	28.2	1.9, 414.4
2006, PNG	Thomas	Hsp	13 (85)	86 (77)	Yes/no	Yes <sup>2</sup>	1.8	0.4, 8.5
Adjusted for smoking								
1995, Taiwan	Ko	Hsp	102 (70)	195 (22)	Yes/no	Yes <sup>3</sup>	6.9	3.1, 15.2
1996, Taiwan	Lu	Pop	40 (83)	160 (24)	Yes/no	Yes <sup>4</sup>	58.4	7.6, 447.6
2000, India	Dikshit	Pop	32 (13)	152 (8)	Yes/no	Yes <sup>5</sup>	1.7	0.9, 3.3
2000, Pakistan	Merchant	Hsp	79 (53)	149 (11)	Never/ever	Yes <sup>6</sup>	9.9	1.8, 55.6
2002, India	Balaran	Hsp	142 (11)	283 (3)	Never/ever	Yes <sup>7</sup>	4.2	1.5, 11.8
2002, Taiwan	Chen	Hsp	22 (86)	29 (30)	Yes/no	Yes <sup>8</sup>	17.1	2.3, 129.0
2003, India	Znaor (a)	Hsp			Never/ever	Yes <sup>9</sup>	2.6	1.8, 3.7
2003, India	Znaor (b)	Hsp			Never/ever	Yes <sup>9</sup>	1.7	1.1, 2.6
2006, PNG	Thomas	Hsp	143 (92)	477 (86)	Yes/no	Yes <sup>10</sup>	2.0	1.0, 4.1

SL, Sri Lanka; PNG, Papua New Guinea; Hsp, Hospital controls; Pop, populations controls. (a) mouth; (b) tongue. Empty enteries represent numbers of cases and controls for tongue and mouth not reported (total cases for mouth and tongue combined is 1563, total controls is 3,638).  
<sup>1</sup>Alcohol matched on age and sex. -<sup>2</sup>Age sex centre education income urban/rural. -<sup>3</sup>Smoking alcohol matched on age and sex. -<sup>4</sup>Smoking alcohol matched on age and sex. -<sup>5</sup>Smoking age. -<sup>6</sup>Smoking (cigarettes) alcohol matched on age and sex. -<sup>7</sup>Smoking alcohol age centre education. -<sup>8</sup>Smoking age sex. -<sup>9</sup>Smoking alcohol age sex centre education. -<sup>10</sup>Smoking age sex centre education income urban/rural.

Discussion

We have confirmed that smoking is a strong independent risk factor for oral cancer and have shown that betel quid (that does not contain tobacco) is also an independent, but weaker, risk factor for oral cancer.

Our study is one of the largest case-control studies of betel quid without tobacco to date, but despite our attempts to characterise the exposures accurately the lack of variation in exposure to tobacco and betel quid reduced our power to detect associations and the CI are therefore wide, particularly for betel quid chewing. All eligible cases and controls approached agreed to take part in our study and taped interviews were conducted by trained interviewers, thus minimising the likelihood of selection and information bias. Furthermore the size, anatomical site or the duration of the patients' awareness of the tumour were not related to reported smoking or betel quid chewing.

A disadvantage of hospital controls is that they differ from the referent population or may be a biased sample of people in that referent population. In PNG, betel quid chewing was not known to be associated with diseases other than oral cancer. Diseases attributable to smoking were less easily defined in PNG than in a Western population. Lung cancer was uncommon, as was cardiovascular disease and it is difficult to make a causal extrapolation between tobacco smoke and chronic lung disease because of the confounding effect of wood smoke in poorly ventilated houses.<sup>20</sup> Other than exclusion of people with oral cancer, diagnosis of controls was not routinely documented in our study. The inclusion of people with a wide variety of conditions presenting to the general wards in PNG would serve to dilute any bias that would occur if one disease were related to the exposure of interest even if the relationship was not obvious. In Western populations, hospitalised patients are more likely to smoke and in 1991 a report of a survey of Angau Provincial Hospital PNG, found 80% of 2000 patients were smokers.<sup>20</sup> As smoking and betel quid chewing were highly correlated in the present study high prevalence of betel quid chewing is also likely. Guardians of patients are likely to share similar attitudes and behaviours with controls attending as patients; in particular, friendship may be a determinant of study exposure or *visa versa*. Although no systematic differences were found between patients and guardians because of the small numbers the opportunity to explore this were limited. On balance, the selection forces leading to hospitalisation have probably led to underestimation of the true risk of oral cancer associated with smoking and chewing.

1088  
E

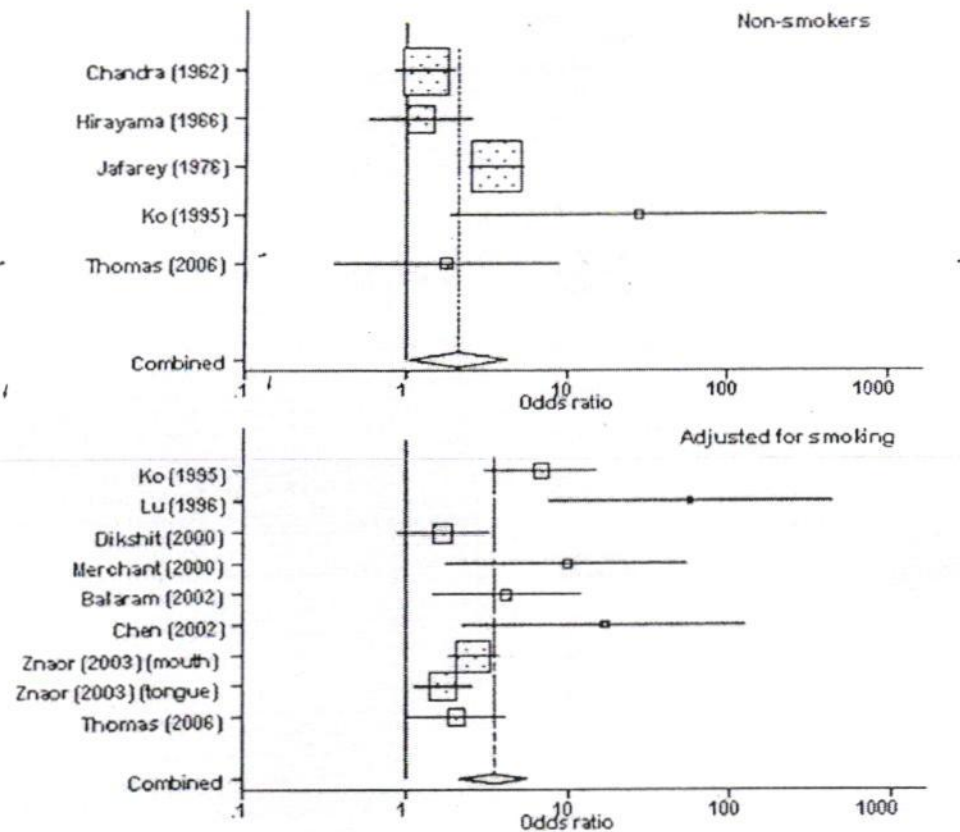

FIGURE 1 – Meta-analysis of studies of betel quid without tobacco.

PNG is a heterogeneous culturally diverse society where over 700 Austronesian and Papuan languages are spoken. The measures of social aspects of wealth and acculturation used in our study were necessarily crude but neither smoking nor betel quid chewing were strongly associated with any of these measures and adjustment for measures of these confounders did not alter the underlying associations making confounding less likely. It is of course possible that other unsuspected variables may have biased the results. It may be helpful in future studies to attempt to measure indicators of traditional lifestyle as well as acculturation. It is uncertain how such cultural factors affect habits such as smoking and betel quid chewing.

The association we observed with smoking in our study was strong and there was a dose-response relationship for both smoking frequency and lifetime tar exposure. These findings are consistent with previous results for increased frequency<sup>17</sup> and tar<sup>21</sup> and are biologically plausible. The different association we observed by tobacco type might reflect the high nitrosamine content which is a feature of air-cured tobacco.<sup>22,23</sup> The lower risk we observed in exsmokers is also consistent with the risks reported in studies in other populations.<sup>24-26</sup>

The relationship we observed with chewing of betel quid was weaker than that for tobacco smoking. Even so the risk was doubled in the highest exposure category and again there was evidence of a dose-response relationship. Only 10 studies have examined the risk of oral cancer in populations where betel quid does not contain tobacco and accounted for the potential confounding effect of smoking tobacco; 4 of these estimated risk in nonsmokers and 7 adjusted for the effect of smoking in the analysis. Exposure to smoking was estimated as a dichotomous outcome (yes versus no or never versus ever) in all of these, and the direction of effect was always towards an increased risk and is consistent with the present study. A meta-analysis of these studies (including the present study) showed evi-

dence of between study heterogeneity, suggesting that effects vary and there is still some uncertainty about the magnitude (but probably not the reality) of the contribution of betel quid without tobacco to oral cancer in these populations. The heterogeneity may be explained in part by the variation in the proportion of the population exposed to betel quid without tobacco. In addition dichotomous outcomes offer only limited evidence of a causal link and ever chewing betel quid without tobacco does not exclude the inclusion of tobacco in the quid at other times. Again, only one of these previous studies reported a dose-response estimate for betel quid without tobacco,<sup>18</sup> which based on small numbers showed a very large but imprecise association for the heaviest chewers, (Adjusted OR 275.6 95% CI 14.8, 5106.5). The present study supports the finding of a dose-response, although the effect size is smaller the estimates are more precise. The value of testing for dose-response trends in judging causality is widely acknowledged, and so the lack of this information from so many reports is disappointing.

The present study thus adds to the literature as we have confirmed the importance of smoking as a dose-related risk factor for oral cancer. This further highlights the need for effective smoking prevention and cessation programmes in developing countries. We have also shown that betel quid chewing is associated in a dose-related manner with increased risk of oral cancer even in a population where the betel quid does not contain tobacco. The finding of a dose-response adds to the only other study reporting a dose effect for this exposure. We have previously reported that the type and use of slaked lime may modify the risk associated with betel quid chewing.<sup>27</sup> It may therefore be that modifications to the composition of betel quid could be an effective means of reducing the risk of oral cancer, but further studies are required, to assess this element of the quid. Here, we have extended previous reviews<sup>3</sup> by presenting previously unpublished data and combining this in a systematic review and meta-analysis.

1089  
2

We have shown that smoking and betel quid chewing are independent risk factors for oral cancer in large case-control study in PNG—a population where betel quid does not contain tobacco. Efforts to reduce the incidence of oral cancer in such populations should aim to reduce the smoking prevalence and discourage betel quid chewing and in particular the use of slaked lime as part of the betel quid.

### Acknowledgements

We also acknowledge the generous support from staff of the Papua New Guinea Institute of Medical Research, the Papua New Guinea Department of Health and the University of Papua New Guinea, the Queensland Institute of Medical Research and the University of Queensland.

### References

1. Parkin DM. International variation. *Oncogene* 2004;23:6329-40.
2. IARC. Betel-quid and areca-nut chewing and some areca-nut derived nitrosamines. IARC Monogr Eval Carcinog Risks Hum 2004;85: 1-334.
3. Thomas S, Wilson AA. Quantitative evaluation of the aetiological role of betel quid in oral carcinogenesis. *Eur J Cancer B Oral Oncol* 1993; 29:265-71.
4. DerSimonian R, Laird N. Meta-analysis in clinical trials. *Control Clin Trials* 1986;7:177-88.
5. Higgins JP, Thompson SG. Quantifying heterogeneity in a meta-analysis. *Stat Med* 2002;21:1539-58.
6. van Wyk CW, Stander I, Padayachee A, Grobler-Rabie AF. The areca nut chewing habit and oral squamous cell carcinoma in South African Indians. A retrospective study. *S Afr Med J* 1993;83:425-9.
7. Nandakumar A, Thimmasetty KT, Sreeramareddy NM, Venugopal TC, Rajanna, Vinutha AT, Srinivas, Bhargava MK. A population-based case-control investigation on cancers of the oral cavity in Bangalore, India. *Br J Cancer* 1990;62:847-51.
8. Wasnik KS, Ughade SN, Zodpey SP, Ingole DL. Tobacco consumption practices and risk of oro-pharyngeal cancer: a case-control study in Central India. *Southeast Asian J Trop Med Public Health* 1998; 29:827-34.
9. Shanta V, Krishnamurthi S. Further study in aetiology of carcinomas of the upper alimentary tract. *Br J Cancer* 1963;17:8-23.
10. Jafarey NA, Zaidi SH. Carcinoma of the oral cavity and oropharynx in Karachi (Pakistan). An appraisal. *Trop Doct* 1976;6:63-7.
11. Chandra A. Different habits and their relation with cancer cheek. Chittaranjan Cancer Hospital, Calcutta. *Natl Cancer Res Centre Bull* 1962;33-36.
12. Ko YC, Huang YL, Lee CH, Chen MJ, Lin LM, Tsai CC. Betel quid chewing, cigarette smoking and alcohol consumption related to oral cancer in Taiwan. *J Oral Pathol Med* 1995;24:450-3.
13. Hirayama T. An epidemiological study of oral and pharyngeal cancer in Central and South-East Asia. *Bull World Health Organ* 1966;34: 41-69.
14. Balaram P, Sridhar H, Rajkumar T, Vaccarella S, Herrero R, Nandakumar A, Ravichandran K, Ramdas K, Sankaranarayanan R, Gajalakshmi V, Munoz N, Franceschi S. Oral cancer in southern India: the influence of smoking, drinking, paan-chewing and oral hygiene. *Int J Cancer* 2002;98:440-5.
15. Merchant A, Husain SS, Hosain M, Fikree FF, Pitiphat W, Siddiqui AR, Hayder SJ, Haider SM, Ikram M, Chuang SK, Saeed SA. Paan without tobacco: an independent risk factor for oral cancer. *Int J Cancer* 2000; 86:128-31.
16. Znaor A, Brennan P, Gajalakshmi V, Mathew A, Shanta V, Varghese C, Boffetta P. Independent and combined effects of tobacco smoking, chewing and alcohol drinking on the risk of oral, pharyngeal and esophageal cancers in Indian men. *Int J Cancer* 2003;105:681-6.
17. Dikshit RP, Kanhere S. Tobacco habits and risk of lung, oropharyngeal and oral cavity cancer: a population-based case-control study in Bhopal, India. *Int J Epidemiol* 2000;29:609-14.
18. Lu CT, Yen YY, Ho CS, Ko YC, Tsai CC, Hsieh CC, Lan SJ. A case-control study of oral cancer in Changhua County, Taiwan. *J Oral Pathol Med* 1996;25:245-8.
19. Chen PC, Kuo C, Pan CC, Chou MY. Risk of oral cancer associated with human papillomavirus infection, betel quid chewing, and cigarette smoking in Taiwan—an integrated molecular and epidemiological study of 58 cases. *J Oral Pathol Med* 2002;31:317-22.
20. Kanandru K. In: 'Tobacco and cancer' Proceedings from the UICC South Pacific Workshop, Honiara, May 6-8, 1991, 51-52p.
21. Gallus S, Altieri A, Bosetti C, Franceschi S, Levi F, Negri E, Dal Maso L, Conti E, Zamboni P, La Vecchia C. Cigarette tar yield and risk of upper digestive tract cancers: case-control studies from Italy and Switzerland. *Ann Oncol* 2003;14:209-13.
22. La Vecchia C, Bidoli E, Barra S, D'Avanzo B, Negri E, Talamini R, Franceschi S. Type of cigarettes and cancers of the upper digestive and respiratory tract. *Cancer Causes Control* 1990;1:69-74.
23. Boffetta P. Black (air-cured) and blond (flue-cured) tobacco and cancer risk. V: Oral cavity cancer. *Eur J Cancer* 1993;29A:1331-5.
24. De Stefani E, Boffetta P, Oreggia F, Mendilaharsu M, Deneo-Pellegrini H. Smoking patterns and cancer of the oral cavity and pharynx: a case-control study in Uruguay. *Oral Oncol* 1998;34:340-6.
25. Schlecht NF, Franco EL, Pintos J, Kowalski LP. Effect of smoking cessation and tobacco type on the risk of cancers of the upper aerodigestive tract in Brazil. *Epidemiology* 1999;10:412-8.
26. Llewellyn CD, Johnson NW, Warnakulasuriya KA. Risk factors for oral cancer in newly diagnosed patients aged 45 years and younger: a case-control study in Southern England. *J Oral Pathol Med* 2004;33:525-32.
27. Thomas SJ, MacLennan R. Slaked lime and betel nut cancer in Papua New Guinea. *Lancet* 1992;340:577-8.

# Univariate and Multivariate Analysis of Prognostic Significance of Betel Quid Chewing in Squamous Cell Carcinoma of Buccal Mucosa in Taiwan

JANG-JAER LEE, DDS, MS,<sup>1,2</sup> JIANG-HUEI JENG, DDS, PhD,<sup>1,2</sup> HSIAO-MEI WANG, PhD,<sup>3</sup>  
HAO-HUENG CHANG, DDS, MS,<sup>2</sup> CHUN-PIN CHIANG, DDS, PhD,<sup>1,2</sup> YING-SHIUNG KUO, DDS, PhD,<sup>1,2</sup>  
WAN-HONG LAN, DDS, PhD,<sup>1,2</sup> AND SANG-HENG KOK, DDS, PhD<sup>1,2\*</sup>

<sup>1</sup>School of Dentistry, College of Medicine, National Taiwan University, Taipei, Taiwan

<sup>2</sup>Department of Dentistry, National Taiwan University Hospital, Taipei, Taiwan

<sup>3</sup>Department of Information Management, Ling-Tung College, Taiwan

**Background and Objectives:** While betel quid (BQ) chewing is clearly the most avoidable risk factor of squamous cell carcinoma of buccal mucosa (BMSCC), little is known about the influence of this habit on the prognosis of BMSCC.

**Methods:** We surveyed 280 patients with BMSCC who were treated during an 8-year period in a cohort study to assess the independent predictive value of pretreatment BQ chewing habit on the prognosis by univariate and multivariate analysis.

**Results:** We found by univariate analysis that sex, age, clinical stage, smoking, and BQ chewing significantly affected the patients' prognosis and only age, clinical stage, and BQ chewing had significant influence on prognosis by multivariate analysis ( $P < 0.05$ ). Further analysis revealed that the prognostic effect of BQ chewing changed in a dose- and time-dependent manner. The risk of death was 31.4-fold higher in heavy user (duration  $>30$  years, daily consumption  $>30$  quids, age of start  $<20$  years old) when compared to those who chewed BQ to a milder degree (duration  $<10$  years, daily consumption  $<15$  quids, age of start  $\geq 20$  years old) ( $P < 0.001$ ).

**Conclusions:** Pretreatment BQ chewing habit worsens the prognosis of BMSCC in Taiwan. BQ chewing is a prognostic indicator that can be used in conjunction with clinical staging to help plan the treatment for the patients.

*J. Surg. Oncol.* 2005;91:41-47. © 2005 Wiley-Liss, Inc.

**KEY WORDS:** squamous cell carcinoma of buccal mucosa; betel quid; prognosis; Taiwan

## INTRODUCTION

There are geographic variations in the age of contraction, sex dominance, and incidence of squamous cell carcinoma of buccal mucosa (BMSCC) among different countries of the world [1-6]. Previous studies indicate that environmental factors play an important role in the pathogenesis of BMSCC. BMSCC is intimately related to oral hygiene and the chronic use of local irritants. It is rare in the United States and Western Europe, where the major risk factors of oral cancers are thought to be alcohol drinking and tobacco smoking. In contrast, BMSCC occurs frequently in India, Southeast Asia (including Taiwan) and numerous other countries, where chewing of betel quid (BQ) with or without tobacco is popular [7-10].

In Taiwan, more than one-tenth of the people aged over 15 years old habitually chew BQ at one time in their life [11,12]; approximately 80% of all oral cancer deaths are associated with the habit of BQ chewing. BQ chewers are predominantly males [1]. The Taiwanese BQ consists of two halves of a fresh areca nut sandwiched with a piece

Grant sponsor: National Taiwan University Hospital; Grant number: 92-M009.

\*Correspondence to: Dr. Sang-Heng Kok, DDS, PhD, Associate Professor and Attending Doctor, Department of Oral and Maxillofacial Surgery, School of Dentistry, National Taiwan University Medical Center, 1 Chang-Te Street, Taipei, Taiwan, 100. Fax: 886-2-23831346. E-mail: kok@ha.mc.ntu.edu.tw

DOI 10.1002/js.20276

Published online in Wiley InterScience (www.interscience.wiley.com).

of the inflorescence of *Piper betel* and lime mixture. It is completely free from tobacco ingredient. Several epidemiological studies have elucidated the relation between BQ chewing and incidence of oral cancer (including BMSCC) in Taiwan [1,10,13]. According to the statistics of Taiwanese government, the incidence and mortality of oral cancer have rapidly increased in the recent years in parallel with the significant growth in BQ consumption. BMSCC accounts for nearly half of all intraoral cancers in Taiwan and buccal mucosa seems to be the site at greatest risk of contracting malignancy in BQ chewers [2,10,14]. It is probably due to the intimate contact between the buccal mucosa and the quid during chewing.

The prognosis of BMSCC is generally poor because of the high incidence of recurrence [6,15-17]. Although significant improvement in the survival time for patients with BMSCC was noted in the 1950s with a change in primary therapy from radiation to surgical treatment [3,18], only minimal improvement in therapeutic efficacy has been made in the ensuing years [4,19]. The prognosis of BMSCC following treatment varied significantly among different countries in the world [5,6,15-17,19]. This indicates that, in addition to tumor- and treatment-related factors, some patient-related risk factors, such as environmental exposure, life style, cultural background, and race, may play a role.

Although the association between various oral habits (BQ chewing, alcohol drinking, or cigarette smoking) and the occurrence of oral cancer (including BMSCC) has been clearly demonstrated by many previous surveys, only a few studies directly focused on the prognostic significance of oral habits [20-22]. Johnston et al. [21] showed that in US, patients with tongue cancer who chronically used tobacco and alcohol had an increased incidence of death when compared to the abstainers. In Denmark, Bundgaard et al. [21] showed that tobacco, but not alcohol, had significant influence on the prognosis of oral SCC. In a study of laryngeal carcinoma, Pradier et al. [22] found that alcohol consumption gave significant, independent prognostic information about survival. To the best of our knowledge, no attempt has been made to directly examine the effect of pretreatment BQ chewing on the prognosis of oral cancer, even in countries with high prevalence of the habit. Our study was the first of its kind that assessed the independent effect of pretreatment BQ chewing habit on the prognosis of BMSCC, the most common and BQ-related oral cancer in Taiwan.

## MATERIALS AND METHODS

### Sampling

The patients with previously untreated BMSCC (ICD.O codes 145.0,1 and 6) who received definitive surgery with or without postoperative radiotherapy and chemotherapy

at the Department of Oral and Maxillofacial Surgery, National Taiwan University Hospital between January 1991 and December 1998 were analyzed. Cases of carcinomas arising from other locations of the oral cavity with secondary buccal involvement, or those having synchronous carcinomas in the upper aerodigestive tract were excluded.

### Preoperative Evaluation

All cases were interviewed in person by well-trained senior residents and the data were validated by the consultants before the operation. A standard, structured questionnaire was used to obtain information on clinical history, age, sex, history of oral habits including whether or not the interviewee was a habitual drinker (one or more drinks per day for at least 1 year), BQ chewer (one or more quids per day for at least 1 year), and smoker (one or more cigarettes per day for at least 1 year). For BQ chewers, duration of the habit, average daily consumption and age at which the habit started were also recorded. The duration of BQ chewing was categorized as less than 15, 15-30 and more than 30 years. The daily consumption of BQ was categorized as less than 15, 15-30 and more than 30 quids. The age of start of BQ chewing was recorded as under or over 20 years old.

Tissue biopsy was performed in every case and the histological diagnosis was confirmed in each case by two oral pathologists before definitive treatment. Preoperative evaluation usually included physical examination, blood examination, EKG, panoramic roentgenography, chest roentgenography, abdominal sonography, Tc<sup>99m</sup> whole body bone scintigraphy, head and neck computed tomography, or magnetic resonance imaging.

The TNM status and clinical stage of each patient were revised according to the most recent recommendations of the American Joint Committee on Cancer [23]. Adequate information was available for accurate staging in all patients. Stages I and II were defined as early stage, and stages III and IV as late stage.

### Treatment

The primary therapy used was surgical treatment or combined therapy consisting of operation followed by irradiation with or without chemotherapy. All surgical treatment was performed by three senior surgeons of the same department. The majority of patients with early disease were treated with wide local excision. Stage III and IV patients and those with tumor adjacent to or directly encroaching on nearby bony structures, underwent composite resection. For cervical lymph nodes, the treatment was ipsilateral or bilateral supraomohyoid neck dissection in T<sub>1-4</sub>N<sub>0</sub> cases; ipsilateral comprehensive neck dissection (levels I-V) with or without contralateral

1092  
R

selective neck dissection in T<sub>1-4</sub>N<sub>1</sub> cases; ipsilateral or bilateral comprehensive neck dissection (levels I-V) in T<sub>1-4</sub>N<sub>2-3</sub> cases.

Patients with late stage diseases; metastases to more than one cervical lymph node; extracapsular spread of nodal tumor; close or involved surgical margin, perineural or lymphovascular invasion of tumor cell under microscopic examination underwent postoperative radiotherapy with or without chemotherapy.

#### Follow-up

The patients were recalled on a regular basis for at least 5 years. They were advised to quit drinking, smoking, and BQ chewing after the surgery and the importance of abstinence was repeatedly reinforced thereafter. At each recall the patients were questioned about the status of habit practicing and their mouths were examined for the presence of dental and mucosal stains that related to smoking and BQ chewing. Patients who failed to abstain from one or more of the oral habits were excluded from the study.

The follow-up period was the duration between the date of initial surgery and the date of last contact or death of the patient. Survival status at the time of last contact was categorized as alive or dead with disease.

#### Statistical Analysis

The non-parametric Spearman rank correlation test was used to examine the correlation between alcohol drinking, cigarette smoking, BQ chewing, and other clinical covariables.

Curves of survival were obtained based on cause-specific deaths by the use of Kaplan-Meier product-limit method, and the 95% confidence intervals (CI) were calculated. Those who survived beyond the end of the follow-up or lost for follow-up at some point were censored.

Univariate test was first performed to analyze the prognostic effect of various clinical covariables on death, by using the Mantel-Cox log-rank test. Multivariate analysis of the independent prognostic significance of the covariables was then performed with the Cox proportional hazards regression model after model fitting.

Reported *P*-values are for a two-sided hypothesis. In any case, probabilities of less than 0.05 were accepted as significance. Statistical Analysis System Version 6.12 (SAS Institute, Cary, NC) and Egret Version 1 (Cytel Software Corp., Cambridge, MA) computer packages were used for the statistics in the study.

### RESULTS

#### Characteristics of the Patients

Two hundred and eighty consecutive patients were collected for analysis between January 1991 and December

1998. They accounted for 57.1% of buccal cancer admissions at the department during the 8-year period. The major reasons for patient exclusion were recurrent tumor, death of other causes, not receiving standard therapy, and poor compliance with the advice of discontinuation of alcohol, BQ and cigarette use after treatment.

At the end of June 2002, the follow-up periods were 1 to 136 months (mean 65.5 ± 4.4, median 56.7 months). The age of the patients ranged from 27 to 77 years with an average of 52.1 ± 1.1 years. The male to female ratio was 10.7 to 1 (256 males, 91% to 24 females, 9%). There was significant difference in age between male and female patients (51.1 ± 1.1 years vs. 62.3 ± 1.8 years, *P* < 0.05). Nearly one third of our BMSCC patients were classified as having stage IV disease (n = 85, 30.4%), followed by stage III (n = 83, 29.6%), stage II (n = 67, 23.9%), and stage I (n = 45, 16.1%). BQ chewing was the most prevalent oral habit among our BMSCC patients (n = 229, 81.2%; 221 males, 8 females), followed by smoking (n = 224, 80%; 221 males, 3 female) and drinking (n = 148, 52.9%; all males). Patients practicing a combination of oral habits were commonly seen (n = 220, 78.6%). The mean age of the patients with the habit of BQ chewing was significantly younger than that of non-chewers (50.0 ± 1.1 years vs. 61.2 ± 1.9 years, *P* < 0.05). There was significant correlation between sex and the oral habits (C.C. = 0.324, 0.384, 0.580 for alcohol, BQ, cigarette habits respectively, all *P* < 0.001). The three oral habits also showed significant correlation to each other. Oral habits did not influence the pretreatment clinical stages of the patients.

#### Death

The overall 5-year survival rate was 58.5%. Patients with stage I disease had the highest 5-year survival rate (83.5%), followed by stage II (70.7%), stage III (56.6%), and stage IV (42.0%). Univariate analysis for the prognostic factors by log-rank test of the Kaplan-Meier estimate identified five variables including sex, age, clinical stage, smoking, and BQ chewing that significantly affected survival (*P* < 0.05) (Table I). Age, clinical stage and BQ chewing had independent prognostic value for survival as shown by multivariate analysis (*P* < 0.05) (Table I).

#### Synergistic Effect of Drinking, Smoking, and BQ Chewing on Prognosis

The synergistic effect of drinking, smoking and BQ chewing on the prognosis of BMSCC patients was analyzed by Cox proportional hazards regression model (Table II). Although there was no statistical significance, it seemed that patients who indulged in BQ chewing and one or two of other oral habits had higher adjusted

10993  
8

TABLE I. Univariate and Multivariate Analysis of Prognostic Indicators on Survival for BMSCC Patients

Parameters	Category (number of patient)	5-year survival rate	RR <sup>b</sup> (95% CI)	ARR <sup>c</sup> (95 % CI)
Sex	Male (256)	0.558	1.0	1.0
	Female (24)	0.875	0.23* (0.07-0.72)	0.38 (0.10-1.36)
Age group (years)	21-40 (38)	0.336	1.0	1.0
	41-60 (198)	0.557	0.51* (0.33-0.79)	0.53* (0.33-0.85)
	>60 (44)	0.903	0.08* (0.03-0.24)	0.11* (0.04-0.35)
Clinical stage	Early stage (112)	0.745	1.0	1.0
	Late stage (168)	0.471	2.59* (1.69-3.97)	2.89* (1.88-4.44)
Alcohol drinking	No (132)	0.611	1.0	1.0
	Yes (148)	0.563	1.28 (0.89-1.85)	0.93 (0.63-1.38)
BQ chewing	No (51)	0.841	1.0	1.0
	Yes (229)	0.529	3.76* (1.84-7.72)	1.72* (1.08-3.70)
Cigarette smoking	No (56)	0.676	1.0	1.0
	Yes (224)	0.563	1.60* (1.01-2.68)	0.82 (0.46-1.45)
Overall	280	0.585		

\*P < 0.05.

<sup>b</sup>Relative risk on death.

<sup>c</sup>Multivariate analysis for relative risk on death after adjusting for variables in each other.

relative risk (ARR) for death when compared with those having only a single habit. Patients who drank and chewed BQ had the poorest prognosis, followed by BQ chewers who simultaneously smoked.

**Effect of Different Parameters Related to BQ Chewing on Prognosis**

Since BQ chewers with BMSCC tended to have higher risk of death when compared with non-BQ chewers with BMSCC (Fig. 1, P < 0.05), the effect of different parameters related to BQ chewing was further investigated (Table III). We found that the prognostic effect of BQ chewing changed in a dose- and time-dependent manner. The Kaplan-Meier survival curves were shown in Figure 2A-C. The greatest risk of death was found in patients who acquired the habit of BQ chewing for

more than 30 years (ARR = 3.33; P = 0.004), consumed more than 30 quids daily (ARR = 5.29; P < 0.001) or fell into the habit at an age younger than 20 (ARR = 3.68; P = 0.002).

The synergistic effect of duration, daily consumption and beginning age of BQ chewing on prognosis of BMSCC was also evident (Table IV). The ARR of death was 31.4-fold higher in BQ chewers with practice duration >30 years, daily consumption >30 quids and beginning age <20 years when compared to chewers with practice duration <10 years, daily consumption <15 quids and beginning age ≥20 years (P < 0.001).

TABLE II. Synergistic Effect of Oral Habits on the Prognosis of BMSCC Patients

Habit (s) <sup>a</sup>	Number of patient	ARR (death) <sup>b</sup>	(95 % CI)	P-value
No habit	18	1.00		
A	5	1.23	(0.21-11.34)	0.68
B	19	1.31	(0.26-6.58)	0.75
C	18	0.87	(0.14-5.29)	0.88
A+B	14	1.94	(0.37-10.22)	0.43
A+C	10	0.55	(0.35-6.78)	0.63
B+C	77	1.72	(0.06-6.12)	0.48
A+B+C	119	1.53	(0.35-6.87)	0.57

<sup>a</sup>A, alcohol drinking; B, betel quid chewing; C, cigarette smoking.

<sup>b</sup>Multivariate analysis for relative risk on death after adjusting for clinical stage and age.

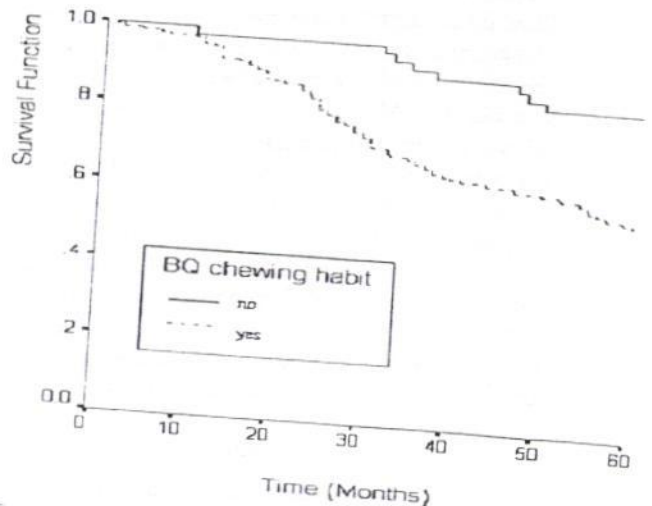

Fig 1. Overall 5-year survival curves in 280 squamous cell carcinoma of buccal mucosa (BMSCC) patients according to betel quid (BQ) chewing habit (log-rank test = 13.12, P < 0.05).

1094  
R

TABLE III. Effect of Different Parameters Related to BQ Chewing on the Prognosis of BMSCC Patients

BQ chewing status (number of patient)	ARR <sup>a</sup> (death) (95% CI)	P-value
Non-user (51)	1	
Duration of BQ chewing		
<15 years (34)	1.20 (0.44-3.26)	0.72
15-30 years (146)	1.29 (0.58-2.87)	0.53
>30 years (49)	3.33 (1.46-7.58)	0.004
Daily consumption of BQ		
<15 quids (42)	0.20 (0.04-0.96)	0.04
15-30 quids (107)	1.50 (0.63-3.57)	0.37
>30 quids (80)	5.29 (2.23-12.57)	<0.001
Age beginning BQ chewing		
<20 years old (77)	3.68 (1.61-8.39)	0.002
≥20 years old (152)	1.16 (0.51-2.61)	0.73

<sup>a</sup>Multivariate analysis for relative risk on death after adjusting for clinical stage, age, drinking, and smoking.

DISCUSSION

The majority of our BMSCC patients (81.2%) had the habit of BQ chewing. Most of the 280 patients (91%) were male and 86.3% of the male patients were BQ chewers. In contrast, only 33.3% of the female patients chewed BQ habitually. It is noteworthy that the average age of onset of BMSCC was 11.2 years earlier in male than in female, and also 11.2 years earlier in BQ chewers when compared with non-chewers. The statistics implied that in Taiwan the pathogenesis and risk factors associated with BMSCC are different between BQ chewers and non-chewers and the impact of BQ chewing on the development of BMSCC was confirmed. In western countries, the incidence of BMSCC is low and smoking and drinking are well-established risk factors for the disease [3,7]. It is interesting to find out that in the non-BQ chewing countries, there is no significant sex predilection in BMSCC and the average onset age is comparable to that of the non-BQ chewers in our study, that is, about 10 years older than that of the chewers [3-5,7,19].

Although drinking, smoking, and BQ chewing have long been condemned as risk factors for oral cancers, the influence of these habits on the prognosis of the disease was less well studied. A few studies [20-22] from the western countries have aimed at the prognostic impact of smoking and drinking on oral cancers but the influence of BQ chewing as a prognostic indicator has not been studied before. Our study is the first that demonstrated, in an area with a high prevalence of the habit, BQ chewing associated not only with the development of oral cancers, but also with the course of the disease. The aim of the study was to evaluate the influences of pretreatment oral habits on the prognosis of BMSCC and patients

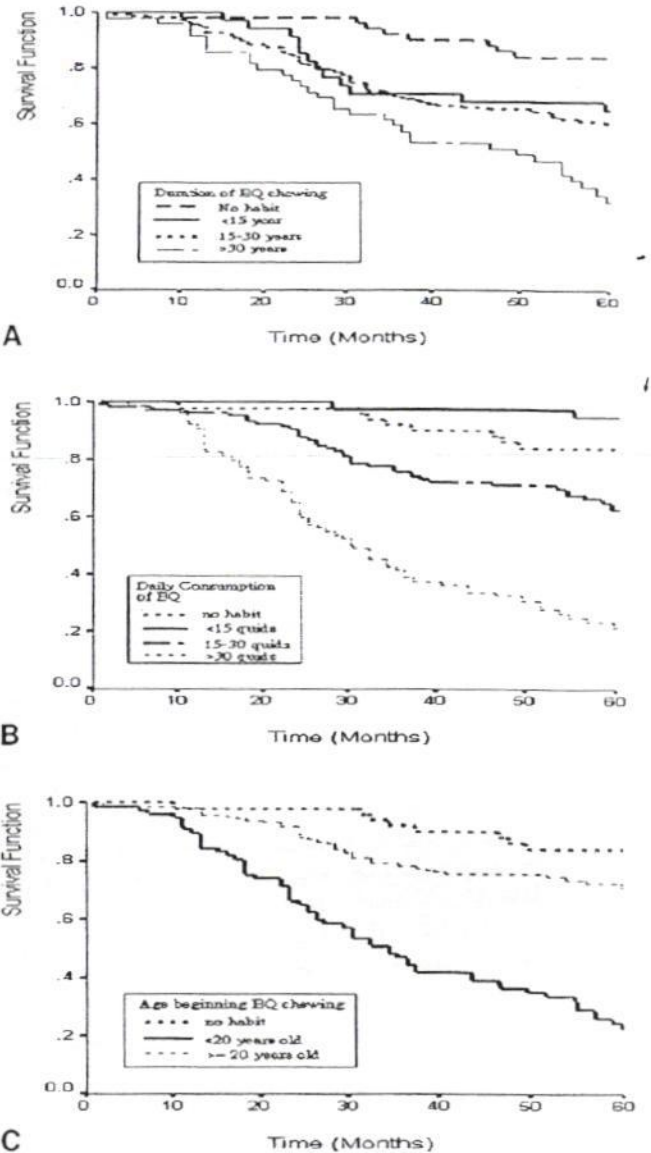

Fig. 2. Overall 5-year survival curves in 280 BMSCC patients. (A) according to duration of BQ chewing ((log-rank test=26.44, P<0.001). (B) according to daily consumption of BQ chewing (log-rank test=102.79, P<0.001). (C) according to beginning age of BQ chewing (log-rank test=77.75, P<0.001).

who failed to quit the habits were excluded. Further investigation is needed if the effects of continual habit practicing after treatment are considered. A much larger sample size is required for such analysis since there are three oral habits under consideration.

Univariate analysis in our study identified sex, age, clinical stage, smoking, and BQ chewing were associated with the prognosis of BMSCC patients. With multivariate analysis, only age, clinical stage, and BQ chewing were shown to have independent prognostic value. Most of the BQ chewers were male and a majority of them also got the

1095  
 k

TABLE IV. Synergistic Effect of Different Parameters Related to BQ Chewing on the Relative Risk of Death for BMSCC Patients

Beginning age (number of patient)	≥20 years old (152)			<20 years old (77)		
	<15 years (26)	15-30 years (117)	30 years (9)	<15 years (8)	15-30 years (29)	>30 years (40)
Duration (number of patient)						
Daily consumption (number of patient)	ARR* (P-value)	ARR (P-value)	ARR (P-value)	ARR (P-value)	ARR (P-value)	ARR (P-value)
<15 quids (42)	1.00	1.19 (0.62)	2.24 (0.08)	0.63 (0.09)	0.76 (0.54)	1.42 (0.58)
15-30 quids (107)	5.97 (0.02)	7.12 (0.02)	13.37 (0.002)	3.79 (0.09)	4.52 (0.08)	8.48 (0.02)
>30 quids (80)	22.08 (<0.001)	26.34 (<0.001)	49.46 (<0.001)	14.01 (<0.001)	16.70 (0.001)	31.37 (<0.001)

\*Multivariate analysis for relative risk on death after adjusting for clinical stage, age, drinking, and smoking.

habits of smoking and drinking. Therefore, the prognostic impact of sex and smoking as demonstrated in the univariate analysis may possibly be ascribed to the confounded effect of BQ chewing.

The findings in our study are apparently different from those of western countries where smoking and drinking are important prognostic indicators of oral cancers [20-22]. The discrepancy may be due to the relatively small number of patients without chewing BQ. Another possible explanation is that oral cancers associated with BQ chewing are probably more aggressive. The biological effects of BQ may be stronger than those of drinking and smoking and the influences of the latter are overwhelmed. In support of this view, it was found that the incidence of BMSCC is much higher in areas where BQ chewing is popular [8-10] and BQ chewers have a higher risk of contracting oral cancers when compared to those who only smoke or drink [1,13]. Furthermore, BMSCC attacks BQ chewers significantly earlier than it attacks the non-chewers.

Although drinking and smoking did not correlate significantly with the prognosis of BMSCC, in the study we found that the risks of death tended to increase in BQ chewers who simultaneously smoked and/or drank as compared to those who got only the habit of BQ chewing. Drinking and smoking may act synergistically with BQ chewing to affect the prognosis of BMSCC patients. However, the mechanism of the interaction of these agents is unknown and further investigation is needed.

The independent effect of BQ chewing on the prognosis of BMSCC suggests that, in addition to its etiologic role, BQ chewing also influences the tumor-host relationship as the disease progresses. Previous studies in our laboratory discovered that the expression of p53, PCNA and p21<sup>ras</sup> was often higher in oral cancers and precancerous lesions from BQ chewers as compared to that of non-chewers [24-27]. Lee et al. [28] showed that the average proportion of deleted mtDNA was significantly higher in non-tumor oral tissues from BQ chewers

comparing to those of non-chewers. Chen et al. [29] found a high frequency of safrole-like DNA adducts in BQ-associated oral squamous cell carcinoma (OSCC) and matched non-cancerous tissues. This was in contrast to the absence of such adducts in all of the non-BQ associated OSCC and paired non-cancerous tissues. Taken together, BQ can induce alterations in oral tissues that may accumulate and result in cancer. It is interesting to note that the BQ-induced changes are found not only in tumor tissues, but also in the adjacent precancerous or even histologically normal tissues. Therefore, the prognostic impact of BQ chewing may result from its field cancerization effect [30] that predisposes the patients to local recurrence and cancer-related death. For this reason, it is thought that a wide safety margin in the surgery, postoperative irradiation, and a recall program reinforcing the abstinence from BQ chewing may help improve the prognosis of BMSCC for BQ chewers.

Besides its direct effects on the oral tissues, BQ chewing also affects the body in a systemic way. It is well known that habitual BQ chewing can alter a person immunological profiles [31-34]. The frequencies of sister-chromatid exchange and chromosome aberrations in peripheral lymphocytes were significantly elevated in betel and tobacco chewers than in normal control [31,32]. Hsu et al. [33] proved that arecoline (a major alkaloid of betel nut) influences cytokine production by mononuclear cells. Moreover, Balaram et al. [34] found that the immunoregulatory status correlated well with the prognosis of patients with oral cancer. On the other hand, BQ chewing may induce nutritional deficiency [35,36] that in turn worsens the prognosis of the patients.

In the study, we found that the prognostic effect of pretreatment BQ chewing is dose- and time-dependent. Those who fell into the habit for a longer period and consumed more BQ daily had a poorer prognosis. Moreover, it is interesting to note that getting into the habit early can worsen the situation even further. BQ chewers who fell into the habit before 20 years old had

1096

f

higher risks of death as compared to those who acquired the habit at an older age. The findings have significant implications in making public health policy. The government should do everything it can to prevent the younger individuals to get into the habit.

In conclusion, the study found that in addition to clinical stage, pretreatment BQ chewing has independent prognostic value for BMSCC in Taiwan. BQ chewers have higher risk of cancer-related death. BQ chewing is a prognostic indicator that can be used in conjunction with clinical staging to help plan the treatment for the patients. The results also demonstrate that the prognostic effect of pretreatment BQ chewing is dose- and time-dependent.

#### REFERENCES

1. Kwan HW: A statistical study on oral carcinomas in Taiwan with emphasis on the relationship with betel quid chewing: A preliminary report. *J Formos Med Assoc* 1976;75:497-505.
2. Lee JJ, Kok SH, Kuo YS, et al.: Carcinoma of buccal mucosa-A representative betel nut oral cancer. *Formos J Med* 1997;1:638-647.
3. Veggers JWM, Snow GB: Squamous cell carcinoma of the buccal mucosa: a review of 85 cases. *Arch Otolaryngol* 1979;105:192-196.
4. Strome SE, To W, Strawderman M, et al.: Squamous cell carcinoma of the buccal mucosa. *Otolaryngol Head Neck Surg* 1999;120:375-379.
5. Chhetri DK, Rawnsley JD, Calcaterra TC: Carcinoma of the buccal mucosa. *Otolaryngol Head Neck Surg* 2000;123:566-571.
6. Nair MK, Sankaranarayanan R, Padmanabhan TK: Evaluation of the role of radiotherapy in the management of the carcinoma of the buccal mucosa. *Cancer* 1988;61:1326-1331.
7. La Vecchia C, Tavani A, Franceschi S, et al.: Epidemiology and prevention of oral cancer. *Oral Oncol* 1997;33:302-312.
8. Janakarajah N, Zain R: Clinical presentation of buccal carcinoma in a review of twenty-nine patients. *Sing Med J* 1984;25:236-239.
9. IARC. Betel-quid and areca-nut chewing. Lyon: International Agency for Research on Cancer Monographs 1986;37:141-202.
10. Chen YK, Huang LM, Lin LM, et al.: Primary oral squamous cell carcinoma: An analysis of 703 cases in southern Taiwan. *Oral Oncol* 1999;35:173-179.
11. Ko YC, Chiang TA, Chang SJ, et al.: Prevalence of betel quid chewing habit in Taiwan and related socio-demographic factors. *J Oral Pathol Med* 1992;21:261-264.
12. Chen JW, Shaw JH: A study on betel quid chewing behavior among Kaohsiung residents aged 15 years and above. *J Oral Pathol Med* 1996;25:140-143.
13. Ko YC, Huang YL, Lee CH, et al.: Betel quid chewing, cigarette smoking and alcohol consumption related to oral cancer in Taiwan. *J Oral Pathol Med* 1995;24:450-453.
14. Cancer registry annual report in Taiwan area, 1996. Department of Health. The Executive Yuan, ROC.
15. Ildstad ST, Bigelow ME, Remensnyder JP: Clinical behavior and results of current therapeutic modalities for SCC of the buccal mucosa. *Surg Gynecol Obstet* 1985;160:254-258.
16. Fang FM, Leung SW, Huang CC, et al.: Combined-modality therapy for squamous carcinoma of the buccal mucosa: Treatment results and prognostic factors. *Head Neck* 1997;19:506-512.
17. Pop LAM, Eijkenboom WMH, de Boer MF, et al.: Evaluation of treatment results of squamous cell carcinoma of the buccal mucosa. *Int J Rad Oncol Biol Phys* 1989;16:483-487.
18. O'Brien PH, Catlin D: Cancer of the cheek (mucosa). *Cancer* 1965;18:1392-1398.
19. Bloom ND, Spiro RH: Carcinoma of the cheek mucosa: A retrospective analysis. *Am J Surg* 1980;140:556-559.
20. Johnston WD, Ballantyne AJ: Prognostic effect of tobacco and alcohol use in patients with oral tongue cancer. *Am J Surg* 1977;134:444-447.
21. Bundgaard T, Bentzen SM, Wildt J: The prognostic effect of tobacco and alcohol consumption in intraoral squamous cell carcinoma. *Oral Oncol, Eur J Cancer* 1994;30:323-328.
22. Pradier R, Gonzalez A, Matos E, et al.: Prognostic factors in laryngeal carcinoma. *Cancer* 1993;71:2472-2476.
23. AJCC. Cancer staging manual. 5th edn. Philadelphia: Lippincott-Raven Publishers, 1997. pp 24-30.
24. Kuo MYP, Chang HH, Hahn LJ, et al.: Elevated ras p21 expression in oral premalignant lesions and squamous cell carcinoma in Taiwan. *J Oral Pathol Med* 1995;24:255-260.
25. Chiang CP, Lang MJ, Liu BY, et al.: Expression of p53 protein in oral submucous fibrosis, oral epithelial hyperkeratosis, and oral epithelial dysplasia. *J Formos Med Assoc* 2000;99:229-234.
26. Chiang CP, Huang JS, Wang JT, et al.: Expression of p53 protein correlates with decreased survival in patients with areca quid chewing and smoking-associated oral squamous cell carcinomas in Taiwan. *J Oral Pathol Med* 1999;28:72-76.
27. Chiang CP, Lang MJ, Liu BY, et al.: Expression of proliferating cell nuclear antigen (PCNA) in oral submucous fibrosis, oral epithelial hyperkeratosis and oral epithelial dysplasia in Taiwan. *Oral Oncol* 2000;36:353-359.
28. Lee HC, Yin PH, Yu TN, et al.: Accumulation of mitochondrial DNA deletions in human oral tissues-effects of betel quid chewing and oral cancer. *Mutat Res* 2001;493:67-74.
29. Chen CL, Chi CW, Chang KW, et al.: Safrrole-like DNA adducts in oral tissue from oral cancer patients with a betel quid chewing history. *Carcinogenesis* 1999;20:2331-2334.
30. van Ojten MGCT, Slootweg PJ: Oral field cancerization: Carcinogen-induced independent events or micrometastatic deposits? *Cancer Epidemiol Biomarkers Prev* 2000;9:249-256.
31. Ghosh R, Ghosh PK: Sister chromatid exchanges in betel and tobacco chewers. *Mutat Res* 1984;139:79-81.
32. Adhvaryu SG, Dave BJ, Trivedi AH: Cytogenetic surveillance of tobacco-areca nut (mava) chewers, including patients with oral cancers and premalignant condition. *Mutat Res* 1991;261:41-49.
33. Hsu HJ, Chang KL, Yang YH, et al.: The effects of arecoline on the release of cytokines using cultured peripheral blood mononuclear cells from patients with oral mucous diseases. *Kaohsiung J Med Sci* 2001;17:175-182.
34. Balaram P, Meenattoor G: Immunology of oral cancer: A review. *Sing Dent J* 1996;21:36-41.
35. Vimokasant S, Nakornchai S, Rungruangsak K, et al.: Food habits causing thiamine deficiency in humans. *J Nutr Sc Vitamin* 1976;22(Suppl):1-2.
36. Weegels P, Heywood P, Jenkins C: Consumption of betel nut and its possible contribution to protein and energy. *Papua New Guinea Med J* 1984;27:37-39.

1097  

*J Oral Pathol Med.* 2002 Jul;31(6):317-22.

**Risk of oral cancer associated with human papillomavirus infection, betel quid chewing, and cigarette smoking in Taiwan--an integrated molecular and epidemiological study of 58 cases.**

Chen PC, Kuo C, Pan CC, Chou MY.

Department of Pathology, Veterans General Hospital, Taipei and National Yang, Ming University, Taiwan.

**Abstract**

**BACKGROUND:** The association between oral squamous cell carcinoma (OSCC) and human papillomavirus (HPV) 6, 11, 16 and 18 is uncertain. Past reports varied in the methodology and results. We conducted this study using in situ PCR in situ hybridization (ISH) assay which was considered as the most sensitive method for detection of viral DNA. We undertook an epidemiologic survey about the history of betel quid chewing and cigarette smoking, since these habits are common in Taiwan.

**METHODS:** In situ PCR ISH was performed on the tumor specimens from 29 patients with OSCC and the oral mucosal specimens from 29 patients without OSCC. Their betel quid chewing and cigarette smoking histories were also reviewed.

**RESULTS:** HPV16, HPV18, betel quid chewing and cigarette smoking were statistically significant risk factors in univariate analysis. HPV6 and 11 were not. Multivariate analysis showed that HPV16 infection (adjusted Odds ratio = 11.20) and betel quid chewing (adjusted Odds ratio = 17.06) remained to be independent factors for OSCC.

**CONCLUSIONS:** Our results showed that HPV16 and betel quid chewing were two major risk factors for OSCC in Taiwan, indicating that they act through different mechanisms in the pathogenesis of OSCC.

J Oral Pathol Med. 1995 Nov;24(10):450-3.

## Betel quid chewing, cigarette smoking and alcohol consumption related to oral cancer in Taiwan.

Ko YC, Huang YL, Lee CH, Chen MJ, Lin LM, Tsai CC.

School of Public Health, Kaohsiung Medical College, Taiwan, Republic of China.

### Abstract

A hospital-based case-control study of matched pairs was conducted to explore (a) the relationship between the use of betel quid chewing, cigarette smoking, alcohol drinking and oral cancer and (b) synergism between these factors. The case group consisted of 104 male and 3 female oral cancer patients and these were compared with 194 male and 6 female matched controls. We found by univariate analysis that alcohol consumption, smoking, betel quid chewing, educational level and occupation were associated with oral cancer. The adjusted odds ratios were to be found elevated in patients who were smoking and betel quid chewing. After adjusting for education and occupation covariates, the incidence of oral cancer was computed to be 123-fold higher in patients who smoked, drank alcohol and chewed betel quid than in abstainers. The synergistic effects of alcohol, tobacco smoke and betel quid in oral cancer were clearly demonstrated, but there was a statistically significant association between oral cancer and betel quid chewing alone. Swallowing betel quid juice (saliva extract of betel quid produced by chewing) or including unripened betel fruit in the quid both seemed to enhance the risks of contracting oral cancer.

## Risk factors for leukoplakia and malignant transformation to oral carcinoma: a leukoplakia cohort in Taiwan

MN Shiu<sup>1</sup>, THH Chen<sup>1</sup>, SH Chang<sup>1</sup> and LJ Hahn<sup>2</sup>

<sup>1</sup>Graduate Institute of Epidemiology, College of Public Health, and <sup>2</sup>School of Dentistry, College of Medicine, National Taiwan University, Taipei, Taiwan

**Summary** The effects of betel nut chewing, smoking and alcohol on the occurrence of leukoplakia and its malignant transformation to oral carcinoma were quantified in a leukoplakia cohort ( $n = 435$ ) from one medical centre between 1988 and 1998 in Taiwan. Sixty oral carcinomas were ascertained in this cohort. A case-control study within the leukoplakia cohort was used to study risk factors. Using the Weibull survival model, the incidence of malignant transformation of leukoplakia was shown to increase with follow-up years. After adjustment for other relevant risk factors, betel nut chewing (adjusted odds ratio (OR) = 4.59; 95% confidence interval (CI) 1.25–16.86) remained a significant risk factor for malignant transformation. Results from the case-control study showed that the adjusted odds ratios for betel nut chewing and smoking on the occurrence of leukoplakia were 17.43 (95% CI 1.94–156.27) and 3.22 (95% CI 1.06–9.78), respectively. Similar findings were observed when daily frequency and duration were taken into account. This implies that cessation of smoking may reduce by 36% leukoplakia cases, while elimination of betel nuts may prevent 62% of leukoplakia and 26% of malignant transformation to oral carcinoma in the underlying population. © 2000 Cancer Research Campaign

**Keywords:** leukoplakia; oral cancer; betel nut chewing; smoking

In Taiwan, the mortality from oral cancer has increased from 3.6 per 1000 in 1971 to 6.4 per 100 000 in 1994. Prevention of oral cancer seems imperative. It is not feasible to detect oral cancers early (Silverman, 1988; Shanta and Krishnamurthi, 1980) and mass screening for oral cancer has not been recommended (Warnakulasuriya and Johnson, 1996). Primary prevention via programmes to eliminate risk factors may become important (Warnakulasuriya and Johnson, 1996). Previous studies have demonstrated that smoking was highly associated with leukoplakia (Bouquot, 1987; Roed-Petersen, 1982; Brugere et al, 1986; Evstifeeva and Zaridze, 1992) but whether betel nut – containing arecoline, lime and piper (one kind of pepper) – was significantly related to leukoplakia has not been fully addressed. Since the consumption of betel nut in Taiwan has been increasing, elucidation of any association is becoming increasingly important. The association between alcohol consumption and leukoplakia is also inconclusive (Blot et al, 1988; Brugere et al, 1986; Evstifeeva and Zaridze, 1992).

Previous studies have shown a wide range of rates of malignant transformation of leukoplakia (0.13–36.4%) (Pindborg et al, 1968; Roed-Petersen, 1971; Banoczy, 1977; Gupta et al, 1980; Silverman et al, 1984; Bouquot et al, 1988). This suggests that the impact of putative risk factors may vary between different populations. The aims of this study were (1) to evaluate the effects of betel nut chewing, smoking and alcohol use on the risk of leuko-

plakia, taking the daily frequency and the duration of three factors into account; and (2) to assess the impact of relevant risk factors on malignant transformation to oral carcinoma, using samples from certain Chinese people in Taiwan.

### MATERIALS AND METHODS

#### Study design and subject selection

According to the WHO definition, a clinical diagnosis of leukoplakia is a keratotic white plaque that cannot be scraped off and cannot be given another specific diagnosis. Oral cancer is classified by the ICD into categories of lip, tongue, gum, mouth floor, buccal, palate, oropharynx, hypopharynx (International Code of Disease, ICD 140–149, excluding 142–147).

A total of 580 cases of leukoplakia diagnosed between June 1988 and February 1998 at one medical centre in Taiwan were ascertained. Of these, 145 patients who were subsequently diagnosed as having lichen planus, oral ulcer, infection, oral candidiasis or skin leukoplakia were excluded leaving 435 subjects in the leukoplakia cohort on which two parts of this study were based (Figure 1). Part A was to follow up the leukoplakia cohort to estimate the incidence of malignant transformation and relevant risk factors. Of the 435 patients, 60 oral carcinomas were identified, among which only 4% had a different location from the leukoplakia. In order to study factors accounting for malignant transformation, information was abstracted from the medical chart on date of diagnosis, location of leukoplakia and risk factors at time of leukoplakia diagnosis, such as betel nut chewing, smoking and alcohol use. These variables were routinely recorded in the medical chart.

Part B was to elucidate the association between risk factors and leukoplakia using a matched case-control study. A total of 100

Received 1 September 1999

Revised 7 December 1999

Accepted 11 January 2000

Correspondence to: THH Chen, Graduate Institute of Epidemiology, College of Public Health, National Taiwan University, Room 213, No 19 Hsueh Road, Taipei, Taiwan

100  
8

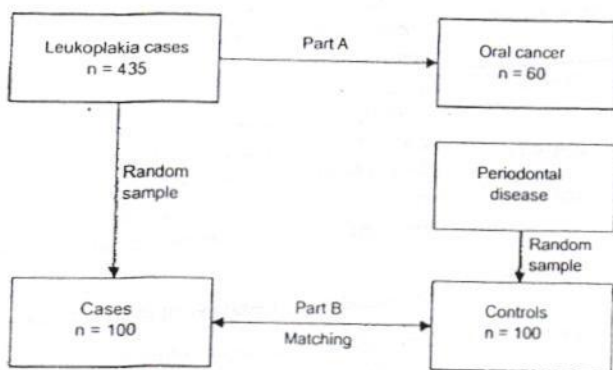

Figure 1 The study design on factors affecting the risk leukoplakia and malignant transformation

leukoplakia cases were randomly selected from the above leukoplakia cohort. Each case was matched to one control for age ( $\pm 3$  years), sex and date of diagnosis ( $\pm 3$  months) derived from a total of 25 882 patients with a diagnosis of periodontal diseases in the same period and hospital as the study group. All cases and controls were free of oral cancer. Since information on risk factors such as betel nut chewing, smoking and drinking for the control group could not be completely obtained from medical charts we collected information via telephone interview. We also interviewed 68 out of 100 leukoplakia case-control pairs to check whether information from the medical chart was consistent with that from telephone interview. Reasons for non-participation included: not at home after three calls, wrong telephone number and refusal. Each participant was asked to provide information on the three risk factors, categorized as: current, former and never. Duration and daily frequency for each risk factor were also collected. A product of duration and daily frequency was defined as the intensity for the current and the former groups. The high or low intensity was categorized according to the median value for each risk factor. It should be noted that since there was a variety of types and brands for the drinkers, it was very difficult to define the dose per day. For alcohol use, only information on daily frequency was asked in telephone interview.

### Statistical methods

For Part A analysis, an accelerated failure time (AFT) model (Marubini and Valsecchi, 1995) was used to estimate the risk of malignant transformation and the association with the location of leukoplakia, betel nut chewing, smoking and drinking. Two parametric models including exponential and Weibull models were employed. All leukoplakia cases were followed until February 1998.

In the analysis of Part B, a conditional logistic regression was performed to investigate the relationship between betel nut chewing, smoking, alcohol drinking, and the occurrence of leukoplakia. The odds ratio (OR), together with exposure information derived from a previous population-based survey (Lee and Chen 1999), gave the population attributable proportion (PAR) for each risk factor (Breslow and Day 1980).

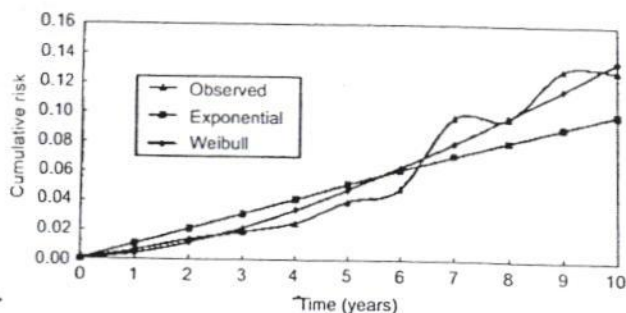

Figure 2 Cumulative risk of malignant transformation, the observed and predicted using the exponential model and the Weibull Model

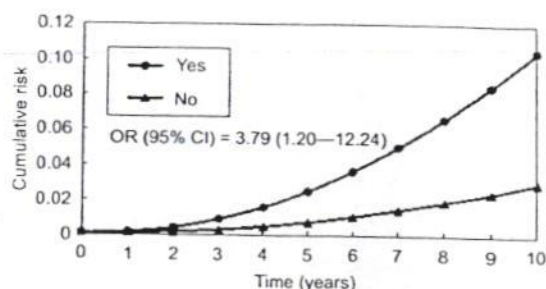

Figure 3 Cumulative risk of malignant transformation by betel nut chewing

## RESULTS

### Malignant transformation from leukoplakia to oral carcinoma

Figure 2 shows that the incidence of malignant transformation in patients with leukoplakia increases with duration of follow-up.

The univariate analysis based on the Weibull model examined whether risk of malignant transformation depends on betel nut chewing, smoking, alcohol use and location of leukoplakia. The cumulative risk stratified by these variables was calculated. Figure 3 reveals that those who chewed betel nut were nearly four times more likely to develop malignant transformation than those who did not (OR = 3.79, 95% confidence interval (CI) 1.20-12.24). Other significant factors influencing malignant transformation include location around the tongue (OR = 3.65, 95% CI 1.09-12.25) and smoking (OR = 2.34, 95% CI 0.62-8.93).

Results from the multivariate analysis (Table 1), which incorporates significant factors in the above univariate analysis plus age and sex, show that betel nut chewing still remains a significant risk for malignant transformation. The hazard ratio for chewing betel nut was 4.59 (95% CI 1.25-16.85) after adjustment for age and sex. However, the effect of smoking and location on malignant transformation is not significant after adjustment for other factors.

### Risk factors for leukoplakia

Table 2 shows that the group of current betel nut chewers had a 26-fold higher (95% CI 3.27-204.00) risk for leukoplakia than that of the 'never' group. The OR for the occurrence of leukoplakia in

1/01  
E

**Table 1** Multivariate analysis of the impact of risk factors on the risk of malignant transformation in patients with leukoplakia, adjusted for age and sex using the Weibull regression model

Risk factors	Odds ratio	95% CI
Location		
Tongue	1.54	0.24-9.73
Buccal	0.30	0.05-1.72
Alveola+lip	0.57	0.06-5.83
Others	1	
Betel nut chewing		
Yes	4.59	1.25-16.86
No	1	
Cigarette smoking		
Yes	2.38	0.62-9.05
No	1	

the current smokers was 5.42 (95% CI 2.17-13.80). The frequent alcohol users had an ninefold (95% CI 1.11-68.7) risk for leukoplakia compared to 'never' group.

With respect to intensity, significant dose-response relationships were observed for three factors. For betel nut chewing, the risk for leukoplakia in the high intensity group (defined by a product of frequency and duration) was 32-fold (95% CI 2.44-408.00) higher than that in the 'never' group. The corresponding figure in the low intensity group was 16 (95% CI 1.37-137.00). As regards smoking, the high intensity group was five times more likely to develop leukoplakia than never smokers (95% CI 1.73-17.20), whereas the OR for the low intensity group compared with the never group was 3.68 (95% CI 1.20-11.20).

Table 3 presents the results of multivariate analysis after adjustment for the effect of the three variables on each other. The adjusted OR for chewing betel nut and smoking in the current group were 17.43 (95% CI 1.94-156.27) and 3.22 (95% CI 1.06-9.78) respectively. The adjusted OR for the use of betel nut and tobacco in the high intensity group were 22.49 (95% CI 1.44-351.42) and 3.09 (95% CI 0.93-10.34) respectively. The effect of alcohol on the occurrence of leukoplakia disappeared after adjustment for betel nut chewing and smoking.

**Consistency of exposure information**

Consistency of exposure information between the medical chart and telephone interview was checked. A good agreement was demonstrated by Kappa statistics (all Kappa values greater than 0.6). To establish whether two different procedures for obtaining information may have affected the results, we estimated the adjusted odds ratios based on the two sources and no significant different results were found.

**DISCUSSION**

A leukoplakia cohort study and the derived matched case-control were designed to elucidate the effect of betel nut chewing, smoking and alcohol use on the three-state natural history of oral cancer, from normal, through leukoplakia and to oral carcinoma. Results from this study had two major practical findings. First, chewing betel nut was demonstrated to influence not only the occurrence of leukoplakia but also its malignant transformation. Although smoking might play a major role in the occurrence of

**Table 2** Univariate analysis of the effect of cigarette smoking, betel nut chewing and alcohol use on the incidence of leukoplakia

Risk factor	Never 1	Odds ratio (95% CI)			
		Status classification		Intensity classification	
		Former	Current	Low	High
Cigarette smoking	1	2.03 (0.61-6.75)	5.42 (2.17-13.80)	3.68 (1.20-11.20)	5.45 (1.73-17.20)
Betel nut chewing	1	3.78 (0.61-23.30)	25.85 (3.27-204.00)	15.61 (1.77-137.00)	31.55 (2.44-408.00)
Alcohol use	Never 1	Occasional 0.63 (0.11-3.65)	Frequent 8.66 (1.11-68.70)		

**Table 3** Multivariate analysis of the effect of alcohol use, betel nut chewing and cigarette smoking on the incidence of leukoplakia, adjusted for the effects of three factors on each other

Risk factor	Never 1	Odds ratio (95% CI)			
		Status classification		Intensity classification	
		Former	Current	Low	High
Cigarette smoking	1	1.04 (0.24-4.59)	3.22 (1.06-9.78)	1.67 (0.45-6.26)	3.09 (0.93-10.30)
Betel nuts chewing	1	2.38 (0.34-16.75)	17.43 (1.94-156.27)	9.06 (1.00-81.64)	22.49 (1.44-351.00)
Alcohol use	Never 1	Occasional 0.28 (0.03-2.56)	Frequent 3.00 (0.27-33.50)		

102  
R

leukoplakia, it may not be a main contributory cause for malignant transformation. If the prevalence of smoking and betel nut chewing among the general population are estimated as 26% and 10% (Lee and Chen, 1999), respectively, this information plus ORs reveals that eliminating the habit of betel nut chewing may reduce the occurrence of leukoplakia by 62% and reduce the rate of malignant transformation by 26% in the underlying population. The corresponding figures for the elimination of smoking were 36% and 26% respectively. Thus, a primary prevention program designed to discourage people from betel nut chewing and smoking seems crucial.

Second, as the likelihood ratio test between the exponential model (constant hazard) and the Weibull model (increasing hazard) was statistically significant ( $\chi^2_{(1)} = 4.30$ ,  $P = 0.038$ ) (Figure 2) this implies that the incidence of malignant transformation from leukoplakia increases with time. Increased risk associated with increasing duration after diagnosis was most marked for leukoplakia in subjects with the habit of betel nut chewing. This might reflect the fact that the proportion of leukoplakia among individuals who chew betel nut also increases year by year.

Few studies have reported on the association between betel nut chewing and leukoplakia or the effect of betel nut chewing on malignant transformation. Only Silverman et al (1984) reported a statistically significant relationship between Pan (a mixture of tobacco and betel nut) and malignant transformation. However, as chewing betel nut in our study did not involve a mixture of tobacco, it is difficult to compare our results with Silverman et al.

A significant positive association between smoking and leukoplakia is consistent with previous reports (Evsstifeeva and Zaridze, 1992; Kulasegaram et al, 1995). Our finding of a dose-response relationship is also in agreement with the study by Kulasegaram et al (1995).

The increased risk of malignant transformation with time in this study is at odds with the previous report that this decreased with time (Silverman et al, 1984). Three possibilities may be relevant. First, the histological distribution of leukoplakia in this study may be different. A persistence of betel nut chewing in leukoplakia cases in Taiwan may provide a second explanation. Third, different treatments might also affect the rate of transformation.

With respect to malignant transformation, only 4% of our leukoplakia cases did not have the same location as oral carcinoma. Such cancers may originate from other sites of leukoplakia but their small number is unlikely to have affected the results.

In conclusion, this study finds that betel nut chewing is a major risk factor not only for the occurrence of leukoplakia but also for malignant transformation. We estimate that elimination of betel nut chewing would prevent 62% of leukoplakia and 26% of malignant transformation.

## REFERENCES

- Banoczy J (1977) Follow-up studies in oral leukoplakia. *J Maxillofac Surg* 5: 69-75
- Blot WJ, McLaughlin JK, Winn DM, et al (1988) Smoking and drinking in relation to oral and pharyngeal cancer. *Cancer Res* 48: 3282-3287
- Bouquot JE (1987) Epidemiology. In: *Pathology of the Head and Neck*, Gnepp DG (ed), Churchill Livingstone: New York; pp. 263-314
- Bouquot JE, Weiland LH and Kurland LT (1988) Leukoplakia and carcinoma in situ synchronously associated with invasive oral/oropharyngeal carcinoma in Rochester, Minn, 1935-1984. *Oral Surg Oral Med Oral Path* 65: 199-207
- Breslow NE and Day NE (1980) Statistical methods in cancer research. volume 1 The analysis of case-control studies. International Agency for Research on Cancer, Lyon; p. 74
- Bruger J, Guenel P, Leclerc A and Rodriguez J (1986) Differential effects of tobacco and alcohol in cancer of the larynx, pharynx and mouth. *Cancer* 57: 391-395
- Evsstifeeva TV and Zaridze DG (1992) Nass use, cigarette smoking, alcohol consumption and risk of oral and oesophageal precancer. *Eur J Cancer* 28B: 29-35
- Gupta PC, Mehta FS, Daftary DK et al (1980) Incidence rates of oral cancer and natural history of oral precancerous lesions in a 10-year follow-up study of Indian villagers. *Community Dent Oral Epidemiol* 8: 283-333
- Kulasegaram R, Downer MC, Jullien JA, Zakrzewska JM and Speight PM (1995) Case-control study of oral dysplasia and risk habits among patients of a dental hospital. *Eur J Cancer* 31B: 227-231
- Lee L and Chen HH (1999) A survey of smoking and betel nut chewing in Taiwan. Technique report of the bureau of health promotion and protection DOH(DOH88-HP-Tobac03)
- Marubini E and Valsecchi MG (1995) *Analysing Survival Data from Clinical Trials and Observational Studies*, pp. 267-292 John Wiley: London
- Pindborg JJ, Jolst O, Renstrup G and Roed-Petersen B (1968) Studies in oral leukoplakia: a preliminary report on the period prevalence of malignant transformation in leukoplakia based on a follow-up study of 248 patients. *J Am Dent Asso* 76: 767-771
- Roed-Petersen B (1971) Cancer development in oral leukoplakia: Follow-up of 331 patients. *J Dent Res* 50: 711
- Roed-Petersen B (1982) Effect on oral leukoplakia of reducing or ceasing tobacco smoking. *Acta Dermato-Venerol* 62: 164-167
- Shanta V and Krishnamurthi S (1980) Combined bleomycin and radiotherapy in oral cancer. *Clinical Radiology* 31: 617-620
- Silverman SJ (1988) Early diagnosis of oral cancer. *Cancer* 62: 1796-1799
- Silverman SJ, Gorsky M and Lozada F (1984) Oral leukoplakia and malignant transformation: A follow-up study of 257 patients. *Cancer* 53: 563-568
- Warnakulasuriya KA and Johnson NW (1996) Strengths and weaknesses of screening programmes for oral malignancies and potentially malignant lesions. *Eur J Cancer Prev* 5: 93-98
- WHO Collaborating Centre for Oral Precancerous Lesions (1978) Definition of leukoplakia and related lesions: an aid to studies in oral precancer. *Oral Surg, Oral Medicine, Oral Pathol* 46: 518-539

1003  
R

Revenue 134

Short communication

<http://www.bjcancer.com>

## Risk of betel chewing for oesophageal cancer in Taiwan

M-T Wu<sup>1,2,3</sup>, Y-C Lee<sup>4</sup>, C-J Chen<sup>5</sup>, P-W Yang<sup>4</sup>, C-J Lee<sup>4</sup>, D-C Wu<sup>4</sup>, H-K Hsu<sup>7</sup>, C-K Ho<sup>2,3</sup>, E-L Kao<sup>8</sup> and J-M Lee<sup>4</sup>

<sup>1</sup>Division of Environmental Health and Occupational Medicine, National Health Research Institutes, Kaohsiung, Taiwan; <sup>2</sup>Department of Occupational Medicine, Kaohsiung Medical University Hospital, Kaohsiung, Taiwan; <sup>3</sup>Graduate Institute of Occupational Safety and Health, Kaohsiung Medical University, Taiwan; <sup>4</sup>Department of Surgery, National Taiwan University Hospital, Taipei, Taiwan; <sup>5</sup>Graduate Institute of Epidemiology, College of Public Health, National Taiwan University, Taipei, Taiwan; <sup>6</sup>Department of Gastroenterology, Kaohsiung Medical University Hospital, Kaohsiung, Taiwan; <sup>7</sup>Department of Chest Surgery, Kaohsiung Veterans General Hospital, Kaohsiung, Taiwan; <sup>8</sup>Department of Chest Surgery, Kaohsiung Medical University Hospital, Kaohsiung, Taiwan

**Summary** Among 104 cases of squamous-cell oesophageal carcinoma patients and 277 controls in Taiwan, after adjusting for cigarette smoking, alcohol consumption, and other confounders, we found that subjects who chewed from 1 to 495 betel-year and more than 495 betel-years (about 20 betel quid per day for 20 years) had 3.6-fold (95% CI = 1.3-10.1) and 9.2-fold risk (95% CI = 1.8-46.7), respectively, of developing oesophageal cancer, compared to those who did not chew betel. © 2001 Cancer Research Campaign <http://www.bjcancer.com>

**Keywords:** oesophageal cancer; squamous-cell carcinoma; betel

Oesophageal cancer is the 11th leading cause of cancer deaths in Taiwan, the 6th among males (DOH/ROC, 1999) and in 1999, the age-adjusted mortality rate was 3.93 per 100 000. Cigarette smoking and alcohol consumption are known to have important effects on this cancer (Pottern et al, 1981; Yu et al, 1988; Tavani et al, 1993).

Areca (betel nut) chewing, is a major addiction in Southeast Asia, especially in India and Taiwan. Although the effect of betel, with or without tobacco, on oesophageal cancer risk has been studied in India (Jussawalla, 1981; Nandakumar et al, 1996), this has not been done in Taiwan, where areca, or betel, is most often chewed with lime and *piper betle* inflorescence (Chen et al, 1999). Because betel quid is not chewed with tobacco in Taiwan, it is possible to investigate the independent risks of betel, and cigarette tobacco and alcohol, on developing oesophageal cancer.

### MATERIALS AND METHODS

#### Selection of cases and controls

Cases were histologically confirmed oesophageal squamous-cell carcinoma from the Department of Chest Surgery at National Taiwan University Hospital in Taipei, Taiwan. The Department of Preventive Medicine at this hospital chose 1 to 3 control subjects without malignancy matched on period of hospitalization age ( $\pm 3$  y) and gender. In total, 104 cases (94 males and 10 females) and 277 controls (256 males and 21 females) were recruited for interview between July, 1996 and October 2000.

Subjects were interviewed by a trained interviewer using a standardized questionnaire. Informed consent was obtained from all subjects. Information on habitual substance use included whether the subject had ever been a habitual betel chewer, cigarette smoker, or alcoholic beverage drinker, what year the subject started and

quit, the duration of consumption, the daily amount consumed, and type of alcoholic beverage consumed. Subjects who reported smoking more than 10 cigarettes per week for at least 6 months were defined as cigarette smokers, those who reported regularly chewing betel quid for at least 6 months were defined as betel chewers, and those who reported drinking beer, wine or distilled spirits more than once a week for at least 6 months were defined as alcoholic beverage drinkers.

#### Statistical analysis

Lifetime consumption of tobacco was calculated by multiplying the number of packs per day by the number of years smoked, giving pack-years. Lifetime consumption of betel quid was calculated as betel years by multiplying the average number of betel quid per day by the number of years chewed. Lifetime consumption of alcoholic beverage was calculated as gram years by multiplying the concentration of alcohol in the consumed beverage by the amount consumed per day by the number of years consumed.

The generalized additive model was used to adjust for other confounding factors without imposing a rigid parametric assumption about their dependence on risk, as in a previous study (Hastie and Tibshirani, 1990). Unconditional logistic regression was used to assess the association between case/control status and chewing betel nut and use of other substances. For substance use, we used no cigarette smoking, no betel chewing, or no alcohol consumption (each as defined above) as baselines and compared these baselines to lifetime consumption of the 3 substances and categorized the use into 2 groups based on the median. In addition, the synergistic or combined effect of these substances was also examined for significance. The data were analysed using the SAS and S-plus statistical packages (SAS, 1988; Hastie and Tibshirani, 1990).

### RESULTS

There were 271 pathology-proven cases of oesophageal squamous-cell carcinoma at National Taiwan University Hospital between July, 1996 and October, 2000. 46% (77/167) of the non-recruited patients were found to have distant metastasis in this study,

Received 15 December 2000

Revised 28 March 2001

Accepted 27 April 2001

Correspondence to: M-T Wu (mingsangwu@yahoo.com) and J-M Lee (ntuhlee@yahoo.com)

1104

**Table 1** The combined effect of substance use in oesophageal cancer with adjustments for other potential confounders

Number of substance use	Cases n (%)	Controls n (%)	OR1	(95% CI)	OR2	(95% CI)
0	16 (15.4)	140 (50.5)	1.0		1.0	
1	14 (13.5)	91 (32.9)	1.8	(0.8, 4.2)	1.5	(0.6, 3.8)
2	36 (34.6)	37 (13.4)	12.3	(5.6, 27.2)	12.4	(5.1, 29.7)
3	38 (36.5)	9 (3.3)	63.9	(23.7, 171.9)	39.2	(13.2, 116.1)

OR1: after adjusting for age (> 65 vs. ≤ 65 y) and gender. OR2: after adjusting for age (> 65 vs. ≤ 65 y), gender, education level, tea consumption, and intake of green vegetable.

whereas only 20% (21/104) of the recruited patients were found to have distant metastasis, a significant difference ( $P < 0.001$ ).

The mean age range of the 104 oesophageal cancer patients and 277 controls were 39–84 (mean 60.6) and 38–81 (mean 62.6) years, respectively. Table 1 shows the odds ratios for the combined effect of these substances on oesophageal cancer after adjusting for other covariates. It was found that the higher the number of substances used concurrently, the higher the risk for oesophageal cancer. Compared to those who abstained from these substances, subjects who consumed 1, 2 and 3 substances concurrently had 1.8-, 12.3- and 63.9-fold risk of oesophageal cancer, respectively (95% CI = 0.8–4.2, 5.6–27.2 and 23.7–171.9) after adjusting for age and gender. The findings remained similar after further adjustment for educational levels, tea consumption and intake of green vegetables. However, we did not find any significant interaction or joint effect between any 2 of these 3 substances (data not shown).

The smoothing plots of age and lifetime consumption of the substances after adjusting for educational levels, tea consumption, and intake of green vegetables are presented in Figure 1. Because the risk of contracting oesophageal cancer increases after about age 65 years, the patients were categorized as 65 years or younger and over 65 years for subsequent analysis, the risk of developing oesophageal cancer in the latter group increasing markedly. The relationship between lifetime consumption of all 3 substances and oesophageal cancer risk also increased sharply. Although there were instances of higher dose users showing a small decline in risk, the observations were relatively few and insignificant. For example, only 8 and 7 observations in the groups of heavy smokers and heavy chewers had a relatively low risk for oesophageal cancer, but they still had a higher risk than those who did not smoke or chew (Figure 1).

We also examined the effect of lifetime consumption of the substances on oesophageal cancer risk. The median cut-off points for lifetime consumption of these substance were 30 pack-year for cigarette smokers, 495 betel-year for areca chewers, and 1220 gram-year for alcoholic beverage drinkers. The group that chewed 495 betel-year chewed an average of about 20 betel quid per day for 20 consecutive years. The group that consumed 1220 gram-year consumed an average of four 300–350 c.c. cans of beer (5% alcohol) per day for 20 consecutive years. In the final regression model, we found that education levels and substance use, including cigarette smoking, betel chewing, and alcohol consumption, were significant risk factors of oesophageal cancer (Table 2). After adjusting for other covariates, subjects who consumed 1–495 betel-year and more than 495 betel-years (about 20 betel quid per day for 20 years) were found to have a 3.6-fold (95% CI = 1.3–10.1) and a 9.2-fold (CI 1.8–46.7) risk, respectively, of developing oesophageal cancer, compared to those who did not. For cigarette smoking, subjects who smoked more than 30 pack-year had a 3.2-

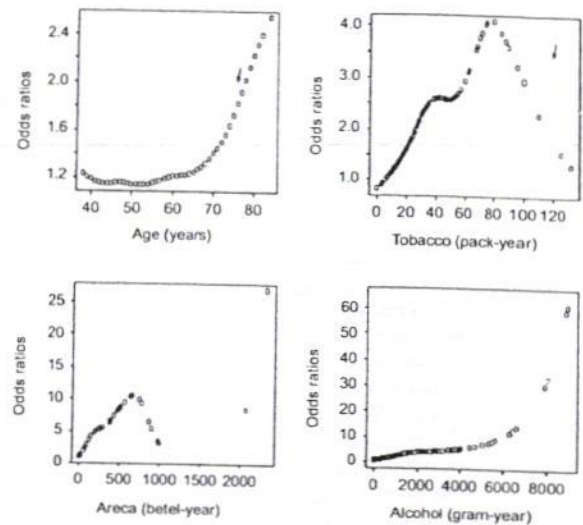

**Figure 1** Regression smoothing plots of oesophageal cancer with age or lifetime consumption of tobacco, areca, or alcohol, using generalized additive modelling approaches to adjust for gender, education level, tea consumption, and intake of green vegetables (6 observations of alcohol (gram-year) > 10 000 and odds ratios > 100 were discarded)

**Table 2** Predictors of oesophageal cancer with substance use and other covariates

Variables	OR1 (95% CI)	OR2 (95% CI)
Age (in years)		
> 65 vs. ≤ 65		1.0 (0.5, 2.2)
Gender		
Female vs. male		2.1 (0.7, 6.9)
Education levels (number of years)		
1–9 vs. none	0.1 (0.05, 0.4)	0.2 (0.08, 0.6)
≥ 10 vs. none	0.05 (0.02, 0.1)	0.09 (0.03, 0.3)
Cigarette smoke (pack-year)		
≤ 30 vs. none	1.6 (0.7, 3.5)	1.8 (0.8, 4.3)
> 30 vs. none	3.2 (1.5, 6.8)	3.7 (1.6, 8.7)
Areca chewing (betel-year)		
≤ 495 vs. none	3.6 (1.3, 10.1)	3.7 (1.3, 10.9)
> 495 vs. none	9.2 (1.8, 46.7)	9.4 (1.8, 48.3)
Alcohol consumption (gram-year)		
≤ 1220 vs. none	2.0 (0.9, 4.6)	2.2 (0.9, 5.1)
> 1220 vs. none	9.7 (4.3, 22.0)	9.8 (4.2, 22.6)
Tea consumption (≥ 1 time per week)		
Yes vs. no		0.6 (0.3, 1.3)
Intake of green vegetables (≥ 1 time per week)		
Yes vs. no		0.3 (0.09, 1.2)

fold risk (95% CI = 1.5–6.8), compared to those who did not smoke. Compared to those who did not drink, subjects who

1605  
R

consumed more than 1220 gram-year of alcohol (about 4 cans of beer per day for 20 years) in a lifetime had a 9.7-fold risk for oesophageal cancer (95% CI = 4.3-22.0). After further adjusting for age, gender, tea consumption and intake of green vegetables, these findings remained the same (Table 2).

## DISCUSSION

Besides cigarette smoking and alcoholic beverage consumption, betel chewing was found to be a major independent risk factor for oesophageal cancer, the more betel consumed during a lifetime, the higher the risk. Previous studies have found that chewing 'pan' (without tobacco), which consists betel leaf, betel nut and slaked lime, was a significant risk factor for oesophageal cancer in India (Jussawalla, 1981; Nandakumar et al, 1996). Our study confirmed this association in Taiwan, although the content of betel quid in India is a little different from that in Taiwan (Chen et al, 1999). Since most of the cases in this study were to evaluate possible surgery, it is likely that a smaller proportion of our cases had metastases than the non-recruited cases.

In Taiwan, *piper betle* fluorescence, which contains about 15 mg g<sup>-1</sup> safrole is frequently added to betel quid (Chen et al, 1999; Liu et al, 2000). During chewing, the concentration of safrole can reach 420 µM. Animal experiments have found that DNA adducts can be formed in the livers of mice by 1'-hydroxysafrole, a metabolite of safrole (Borchert et al, 1973; Ioannides et al, 1981; Randerath et al, 1984; Reddy and Randerath, 1990). In addition, Ramchandani and his co-workers (1998) found that administration of 25 mg pan masala extract, a dry powder mixture of areca nut, catechu, lime, and some unspecific spices and flavouring agents, to diethylnitrosamine-initiated ICRC mice significantly enhanced the growth of oesophagus papilloma. These authors concluded that habitual use of pan-masala may exert a carcinogenic and co-carcinogenic influence in the stomach and oesophagus.

The prevalence of betel chewing in the Taiwanese population is over 10% (Ko et al, 1992). One study reporting an association between betel chewing and oral cancer (Ko et al, 1995) found that subjects who swallowed betel juice were at a significantly higher risk than those who did not. These workers therefore stressed the importance of examining the effect of betel chewing on cancer of the pharynx, larynx, oesophagus and stomach. Although we demonstrated that chewing betel quid can cause oesophageal cancer, we did not collect information on whether betel juice was swallowed. Another limitation is that we lack information on the type of substances consumed with betel nut. Although most Taiwanese people consume a combination of betel nut, *piper betle* fluorescence and lime paste, some use betel nut wrapped in betel leaf. Betel leaf contains eugenol and hydroxycavicol, which are thought to be antimutagenic and anticarcinogenic (Bhide et al, 1991; Ko et al, 1995). The latter workers have reported that chewing betel nut wrapped in betel leaf seemed to be less of an oral cancer risk than the combination of betel nut, *piper betle* fluorescence and lime paste.

We found a combined effect of consuming cigarettes, areca, and alcohol on oesophagus cancer risk, but not a significant joint or synergistic effect caused by any two of the substances: this might be due to our small sample size.

In conclusion, in addition to cigarette smoking and alcohol consumption, areca chewing is an independent potent risk factor for oesophagus cancer in Taiwan and also a combined effect of these 3 substances.

## ACKNOWLEDGEMENTS

This research was supported by a grant from National Science Council, Republic of China (Grant No. NSC 89-2314-B-037-113) and an award of the American Bureau for Medical Advancement in China, Inc. (ABMAC) for Ming-Tsang Wu.

## REFERENCES

- Bhide SV, Zariwala MBA, Amonkar AJ and Azuine MA (1991) Chemopreventive efficacy of a betel leaf extract against benzo[a]pyrene-induced forestomach tumors in mice. *J Ethnopharmacol* 34: 207-213
- Borchert P, Wislocki PG, Miller JA and Miller EC (1973) The metabolism of the naturally occurring hepatocarcinogen safrole to 1'-hydroxysafrole and the electrophilic reactivity of 1'-acetoxysafrole. *Cancer Res* 33: 575-589
- Chen CL, Chu CW, Chang KW and Liu TY (1999) Safrole-like DNA in oral tissue from oral cancer patients with a betel quid chewing history. *Carcinogenesis* 20: 2331-2334
- Department of Health, Republic of China (1999) "Health Statistics: II. Vital Statistics." Department of Health, Taipei.
- Hastie TJ and Tibshirani RJ (1990) Generalized additive models. New York: Chapman & Hall
- Ioannides C, Delaforge M and Parke DV (1981) Safrole: Its metabolism, carcinogenicity and interactions with cytochrome p-450. *Fd Cosmet Toxicol* 19: 657-666
- Jussawalla DJ (1981) Oesophageal cancer in India. *J Cancer Res Clin Oncol* 99: 29-33
- Ko YC, Chiang TA, Chang SJ and Hsieh SF (1992) Prevalence of betel quid chewing habit in Taiwan and related socio-demographic factors. *J Oral Pathol Med* 21: 261-264
- Ko YC, Huang YL, Lee CH, Chen MJ, Lin LM and Tsai CC (1995) Betel quid chewing, cigarette smoking and alcohol consumption related to oral cancer in Taiwan. *J Oral Pathol Med* 24: 450-453
- Liu CJ, Chen CL, Chang KW, Chu CH and Liu TY (2000) Safrole in betel quid may be a risk factor for hepatocellular carcinoma: case report. *CMAJ* 162: 359-360
- Nandakumar A, Anantha N, Pattabhiraman V, Prabhakaran PS, Dhar M, Pottaswamy K, Venugopal TC, Reddy NM, Rajanna, Vinutha AT and Srinivas (1996) Importance of anatomical subsite in correlating risk factors in cancer of the oesophagus-report of a case-control study. *Br J Cancer* 73: 1306-1311
- Pottem LM, Morris LE, Blot WJ, et al. (1981) Esophageal cancer among Black men in Washington, DC. I. Alcohol, tobacco and other risk factors. *J Natl Cancer Inst* 67: 777-783
- Ramchandani AG, D'Souza AV, Borges AM and Bhisey RA (1998) Evaluation of carcinogenic/co-carcinogenic activity of a common chewing product, pan masala, in mouse skin, stomach and esophagus. *Int J Cancer* 75: 225-232
- Randerath K, Haglund RE, Phillips DH and Reddy MV (1984) <sup>32</sup>P-post-labelling analysis of DNA adducts formed in the livers of animal treated with safrole, estragole and other naturally-occurring alkenylbenzenes. I. Adult female CD-1 mice. *Carcinogenesis* 5: 1613-1622
- Reddy MV and Randerath K (1990) A comparison of DNA adduct formation in white blood cells and internal organs of mice exposed to benzo[a]pyrene, dibenzo[*c,g*]carbazole, safrole and cigarette smoke condensate. *Mutat Res* 241: 37-48
- SAS Institute Inc. (1988) SAS\* Language Guide for Personal Computers, Release 6.03 Edition. Cary, NC: SAS Institute Inc.
- Tavani A, Negri E, Franceschi S and Vecchia CL (1993) Risk factors for esophageal cancer in women in Northern Italy. *Cancer* 72: 2531-2536
- Yu MC, Garabrant DH, Peters JM and Mack TM (1988) Tobacco, alcohol, diet, occupation and carcinoma of the esophagus. *Cancer Res* 48: 3845-3848

1006  
B

## Nutritional risk factors in esophageal cancer.

Nayar D, Kapil U, Joshi YK, Sundaram KR, Srivastava SP, Shukla NK, Tandon RK.

Department of Human Nutrition and Institute of Rotary Cancer, All India Institute of Medical Sciences, Ansari Nagar, New Delhi 110 029.

### Abstract

**OBJECTIVE:** The present case-control study was undertaken with the objective to study the nutritional risk factors associated with esophageal cancer.

**METHODOLOGY:** One hundred and fifty diagnosed esophageal cancer patients and an equal number of healthy individuals constituted the patient and control groups, respectively. Dietary consumption pattern during the preceding 20 years prior to the diagnosis of esophageal cancer was assessed utilising the standard food frequency questionnaire method. Information on alcohol consumption, smoking habits, chewing of betel leaf with tobacco was also collected.

**RESULTS:** Multivariate analysis revealed that the risk of esophageal cancer was 7.81 times ( $p < 0.01$ ) higher with daily consumption of alcohol. The risk increased to 3.16 times ( $p < 0.01$ ) with the daily habit of chewing of betel leaf with tobacco. Nearly a two fold risk was observed when the consumption of "other vegetables" was less than four times per week. A 1.95 times ( $p < 0.01$ ) increase in risk was observed with the daily habit of bidi smoking.

**CONCLUSION:** Cancers in general are multifactorial in origin, and several environmental interactions are possible. It is not easy to quantify the contribution of diet to cancer risk. However, the results of the present study suggested that nutritional factors do play a role.

1007  
R

# Short Communication

## Relationship between site of oesophageal cancer and areca chewing and smoking in Taiwan

M-T Wu<sup>1</sup>, D-C Wu<sup>2</sup>, H-K Hsu<sup>3</sup>, E-L Kao<sup>4</sup> and J-M Lee<sup>5</sup>\*

<sup>1</sup>Graduate Institute of Occupational Safety and Health and Department of Occupational Medicine, Kaohsiung Medical University, Kaohsiung, Taiwan; <sup>2</sup>Department of Gastroenterology, Kaohsiung Medical University Hospital, Kaohsiung, Taiwan; <sup>3</sup>Department of Chest Surgery, Kaohsiung Veterans General Hospital, Kaohsiung, Taiwan; <sup>4</sup>Department of Chest Surgery, Kaohsiung Medical University Hospital, Kaohsiung, Taiwan; <sup>5</sup>Department of Surgery, National Taiwan University Hospital, Taipei, Taiwan

Epidemiology

Among 309 male patients, those who had heavily consumed betel and tobacco were more likely than nonchewers (OR = 2.91; 95% CI = 1.36–6.25) and nonsmokers (OR = 2.49; 95% CI = 1.02–6.08) to develop cancer in the upper and middle third of the oesophagus, respectively; the effects of alcohol did not dominate in any third.  
*British Journal of Cancer* (2003) 89, 1202–1204. doi:10.1038/sj.bjc.6601251 www.bjcancer.com  
 © 2003 Cancer Research UK

**Keywords:** oesophageal cancer; anatomic site; cigarette smoking; betel chewing

Our earlier study reported that habitual substance uses, including cigarettes, alcohol and areca, were the major risk factors for developing oesophageal squamous cell carcinoma in Taiwan (Wu *et al*, 2001). Although much research has investigated oesophageal cancer risk factors (Nandakumar *et al*, 1996; Phukan *et al*, 2001; Wu *et al*, 2001), only one study, to our knowledge, from India has examined the association between substance use and the anatomic site of oesophageal cancer lesions (Nandakumar *et al*, 1996). We therefore attempted to clarify the influence of substance use on the anatomical site of oesophageal cancer occurrence in Taiwan.

**Location and staging classification of oesophageal cancer**  
 Lesions were classified with respect to their location in the upper, middle or lower third of the oesophagus (Rosenberg *et al*, 1981; Chalasani *et al*, 1998). Upper-third lesions extended from the cricopharyngeal sphincter (15 cm) to the tracheal bifurcation (23 cm). Middle-third lesions extended from 23 cm to the

### MATERIALS AND METHODS

#### Selection of subjects

Over 6 years (1996–2002), we recruited 309 Taiwanese male patients with pathologically proved oesophageal squamous cell carcinoma from the National Taiwan University Hospital (Taipei), Kaohsiung Medical University Hospital and Kaohsiung Veterans General Hospital (Kaohsiung).  
 Subjects were interviewed by trained interviewers who collected demographic and substance use data by using a standardised questionnaire (Wu *et al*, 2001). This study was approved by Kaohsiung Medical University Hospital's IRB. Informed consent was obtained from all subjects. Information on habitual substance use included whether the subject had been a habitual areca chewer, cigarette smoker or alcoholic beverage drinker. Subjects who had smoked more than 10 cigarettes week<sup>-1</sup> for at least 6 months were defined as cigarette smokers. Those who had regularly chewed betel quid for at least 6 months were defined as betel chewers. And those who had drunk beer, wine or distilled spirits more than one time week<sup>-1</sup> for at least 6 months were defined as alcoholic beverage drinkers.

**Table 1** Demographic and clinical characteristics of oesophageal cancer (n = 309)

Variables	n (%)
Age (years)	
≤ 65	184 (59.5)
> 65	125 (40.5)
Educational levels	
≤ Primary school	86 (27.8)
High school	39 (12.6)
≥ College	
Location of lesion	
U/3	57 (18.5)
M/3	129 (41.7)
L/3	82 (26.5)
U/3+M/3	11 (3.6)
M/3+L/3	30 (9.7)
Stage*	
Stage 0	2 (0.7)
Stage I	34 (12.5)
Stage IIA	51 (18.6)
Stage IIB	34 (12.4)
Stage III	111 (40.5)
Stage IV	42 (15.3)

U = upper; M = middle; L = lower \*Missing = 35

\*Correspondence: Dr M-T Wu; E-mail: mingtsangwu@yahoo.com or Dr J-M Lee; E-mail: jangming@hamc.ntu.edu.tw  
 Received 29 April 2003; revised 9 July 2003; accepted 9 July 2003

108

approximate level of the T9 vertebral body (32 cm). Lower-third lesions extended from 32 cm to the gastro-oesophageal junction (40 cm). If the lesion involved more than one-third, both locations were recorded. The American Joint Committee on Cancer (AJCC) staging system was used (AJCC, 1988).

### Statistical analysis

Unconditional logistic regression assessed the association between cancer location and substance use. Lesions in a given oesophageal third were compared to the remainder of the oesophagus.

For substance use, we used no cigarette smoking, no areca chewing and no alcohol consumption as baselines and compared these baselines to lifetime consumption. Users of substances were subdivided into two groups based on median levels of substance use. Lifetime consumption of tobacco was calculated by multi-

plying number of packs day<sup>-1</sup> by the number of years smoked, yielding pack-years. Lifetime betel consumption was calculated by multiplying the average number of betel quids day<sup>-1</sup> by the number of years chewed, yielding betel-years and alcohol by the number of years alcohol had been drunk (Wu *et al*, 2001). Variables in the models included age (>65 and ≤65 years), educational level (≥college, high school and ≤elementary school) and substance use (tobacco, alcohol and areca). All *P*-values were two-sided.

### RESULTS

In total, 18.5% (57 out of 309), 41.7% (129 out of 309) and 26.5% (82 out of 309) of cancer lesions were located in the upper, middle or lower third of oesophagus, respectively (Table 1); 3.6% (11 out

**Table 2** Relationship of substance use with site of oesophageal cancer (n = 309)

Variables	Upper third n (%)	Non-upper third n (%)	OR (95% CI)	AOR (95% CI)
Cigarette smoking (pack-years)				
Nonsmokers	11 (14.5)	41 (15.9)	1.00	1.00
≤35	30 (39.5)	114 (44.2)	1.29 (0.45-3.65)	1.31 (0.41-4.21)
>35	35 (46.0)	103 (39.9)	1.78 (0.64-5.00)	1.99 (0.63-6.24)
Areca chewing (betel-years)				
Nonchewers	43 (56.6)	162 (62.8)	1.00	1.00
≤400	14 (18.4)	63 (24.4)	0.94 (0.47-1.87)	1.13 (0.52-2.44)
>400	19 (25.0)	33 (12.8)	2.40 (1.22-4.71)	2.91 (1.36-6.25)*
Alcohol consumption (years)				
Nondrinkers	20 (26.3)	58 (22.5)	1.00	1.00
≤32	32 (42.1)	104 (40.3)	1.02 (0.49-2.13)	0.70 (0.28-1.76)
>32	24 (31.6)	96 (37.2)	0.86 (0.40-1.86)	0.57 (0.24-1.35)
Variables	Middle third n (%)	Non-middle third n (%)	OR (95% CI)	AOR (95% CI)
Cigarette smoking (pack-years)				
Nonsmokers	11 (6.5)	41 (14.4)	1.00	1.00
≤35	79 (46.5)	62 (44.6)	2.32 (1.03-5.19)	2.22 (0.91-5.47)
>35	80 (47.0)	57 (41.0)	2.55 (1.14-5.74)	2.49 (1.02-6.08)*
Areca chewing (betel-years)				
Nonchewers	101 (59.4)	80 (57.6)	1.00	1.00
≤400	44 (25.9)	32 (23.0)	1.09 (0.63-1.87)	0.79 (0.43-1.45)
>400	25 (14.7)	27 (19.4)	0.73 (0.40-1.36)	0.52 (0.26-1.02)
Alcohol consumption (years)				
Nondrinkers	27 (15.9)	30 (21.6)	1.00	1.00
≤32	77 (45.3)	57 (41.0)	1.50 (0.81-2.80)	1.22 (0.57-2.64)
>32	66 (38.8)	52 (37.4)	1.41 (0.75-2.66)	1.16 (0.57-2.40)
Variables	Lower third n (%)	Non-lower third n (%)	OR (95% CI)	AOR (95% CI)
Cigarette smoking (pack-years)				
Nonsmokers	18 (16.1)	13 (6.6)	1.00	1.00
≤35	50 (44.6)	91 (46.2)	0.40 (0.18-0.88)	0.40 (0.16-0.99)*
>35	44 (39.3)	93 (47.2)	0.34 (0.15-0.76)	0.31 (0.13-0.76)*
Areca chewing (betel-years)				
Nonchewers	70 (62.5)	111 (56.4)	1.00	1.00
≤400	25 (22.3)	51 (25.9)	0.78 (0.44-1.37)	0.91 (0.48-1.71)
>400	17 (15.2)	35 (17.8)	0.77 (0.40-1.48)	0.89 (0.43-1.81)
Alcohol consumption (years)				
Nondrinkers	23 (20.5)	34 (17.3)	1.00	1.00
≤32	43 (38.4)	91 (46.2)	0.70 (0.37-1.33)	0.96 (0.43-2.17)
>32	46 (41.1)	72 (36.5)	0.94 (0.50-1.80)	1.36 (0.64-2.90)

AOR = after adjusting for age (>65 vs ≤65 years), educational level (≤primary school, high school, ≥college) and substance use (tobacco, alcohol and areca). \**P* < 0.01

109

of 309) and 9.7% (30 out of 309) of cancers involved both upper and middle thirds or middle and lower thirds of the oesophagus, respectively.

Median cutoff points for lifetime consumption of these substances were 35 pack-years for smokers, 400 betel-years for areca chewers (about 20 betel quid day<sup>-1</sup> for 20 consecutive years) and 32 years for alcoholic beverage drinkers. After adjusting for age ( $\leq 65$  vs  $> 65$  years), educational level ( $\leq$  primary school vs  $\geq$  college and high schools vs  $\geq$  college) and other substance use (tobacco and alcohol), we found that compared to nonchewers, subjects who had more than a 400 betel-year history were 2.91-fold more likely to develop cancer in the upper third of the oesophagus (95% CI = 1.36–6.25) (Table 2). In addition, we found that subjects who had smoked more than 35 pack-years were 2.49-fold more likely to develop cancer in the middle third of the oesophagus than were nonsmokers (95% CI = 1.02–6.08). Results remained similar after adjusting for clinical stage ( $>$  Stage II vs  $\leq$  Stage II) (data not shown). In contrast, smokers were less likely to develop cancer in the lower third of oesophagus than were nonsmokers. We found no significant effect of alcohol consumption on the location of oesophageal cancer.

### DISCUSSION

Very few studies have investigated the relationship between habitual substance use and location of oesophageal cancer (Nandakumar *et al*, 1996). Nandakumar *et al* studied oesophageal cancer (343 cases and 686 controls) in India and found that chewing areca preparations were associated with an increased risk for developing cancer in the middle third of the oesophagus. In contrast, chewing tobacco was associated with lesions in the lower third.

### REFERENCES

American Joint Committee on Cancer (AJCC) (1988). In: *Manual for Staging of Cancer*, Beahrs OH, Henson DE, Hutter RVP, Myers MH (eds) 3rd edn, pp. 63–67. Philadelphia: JB Lippincott

Chalasani N, Wo JM, Waring JP (1998) Racial differences in the histology, location, and risk factors of esophageal cancer. *J Clin Gastroenterol* 26: 11–13

Ko YC, Huang YL, Lee CH, Chen MJ, Lin LM, Tsai CC (1995) Betel quid chewing, cigarette smoking and alcohol consumption related to oral cancer in Taiwan. *J Oral Pathol Med* 24: 450–453

Lee CH, Ko YC, Huang HL, Chao YY, Tsai CC, Shieh TY, Lin LM (2003) The precancer risk of betel quid chewing, tobacco use and alcohol consumption in oral leukoplakia and oral submucous fibrosis in southern Taiwan. *Br J Cancer* 88: 366–372

In Taiwan, tobacco is smoked, instead of being added to areca preparations for chewing. Therefore, we speculate that the inhalation of carcinogens from cigarette smoking indirectly affect the oesophagus after entering into the blood stream via pulmonary capillary absorption. Our results agree with those of Nandakumar *et al* (1996) who also found that cigarette smoking more likely affected the middle rather than upper third of the oesophagus.

On the other hand, the association that we found between areca chewing and oesophageal cancer in the upper third differs from the findings of Nandakumar *et al* (1996). Areca is chewed and sometimes the areca juice is swallowed. Therefore, besides the oral cavity and pharynx, the first contact area of areca juice is the upper third of the oesophagus. Since chewing areca can cause oral and pharyngeal cancers (Ko *et al*, 1995; Lee *et al*, 2003), our findings suggest that lesions in the upper third of the oesophagus might be due to direct mucosal exposure to areca preparation contents.

In summary, we found that chewing areca and smoking cigarettes were associated with lesions in the upper and middle thirds of the oesophagus, respectively. Further studies need to examine whether tissue from areca-associated oesophageal cancer is associated with elevated levels of areca-associated DNA adducts in the upper third of oesophagus. In addition, our findings need to be confirmed in animal experiments.

### ACKNOWLEDGEMENTS

This research was supported by grants from the Taiwan National Science Council (NSC 90-2320-B-037-040 and NSC 90-2320-B-037-052), the Taiwan National Health Research Institute (NHRI-CN-IN-9007P) and the Faculty Research Innovation Fund of Kaohsiung Medical University (Drs TF Chen and OL Chen).

Nandakumar A, Anantha N, Pattabhiraman V, Prabhakaran PS, Dhar M, Puttaswamy K, Venugopal TC, Reddy NM, Rajanna, Vinutha AT, Srinivas (1996) Importance of anatomical subsite in correlating risk factors in cancer of the oesophagus – report of a case – control study. *Br J Cancer* 73: 1306–1311

Phukan RK, Ali MS, Chetia CK, Mahanta J (2001) Betel nut and tobacco chewing; potential risk factors of cancer of oesophagus in Assam, India. *Br J Cancer* 85: 661–667

Rosenberg JC, Franklin R, Steiger Z (1981) Squamous cell carcinoma of the thoracic esophagus: an interdisciplinary approach. *Curr Probl Cancer* 5: 1–52

Wu MT, Lee YC, Chen CJ, Yang PW, Lee CJ, Wu DC, Hsu HK, Ho CK, Kao EL, Lee JM (2001) Risk of betel chewing for oesophageal cancer in Taiwan. *Br J Cancer* 85: 658–660

10/10  
A

## Betel quid chewing as a risk factor for hepatocellular carcinoma: a case-control study

JF Tsai<sup>1</sup>, LY Chuang<sup>2</sup>, JE Jeng<sup>3</sup>, MS Ho<sup>4</sup>, MY Hsieh<sup>1</sup>, ZY Lin<sup>1</sup> and LY Wang<sup>1</sup>

<sup>1</sup>Department of Internal Medicine, <sup>2</sup>Biochemistry, and <sup>3</sup>Clinical Laboratory, Kaohsiung Medical University College of Medicine; <sup>4</sup>Institute of Biomedical Sciences, Academia Sinica, Taiwan, Republic of China

**Summary** The role of betel quid chewing in the aetiology of hepatocellular carcinoma (HCC) was evaluated in a case-control study including 263 pairs of age- and sex-matched HCC patients and healthy controls. Serum hepatitis B surface antigen (HBsAg), and antibodies to hepatitis C virus (anti-HCV) were determined, and standardized personal interview conducted using a structured questionnaire. Multivariate analysis indicated that betel quid chewing (odds ratio (OR), 3.49; 95% confidence interval (CI), 1.74–6.96), HBsAg (OR, 16.69; 95% CI, 9.92–28.07), anti-HCV (OR, 38.57; 95% CI, 18.15–81.96), and educational duration of less than 10 years (OR, 1.71; 95% CI, 1.05–2.78) are independent risk factors of HCC. In addition, there was an additive interaction between betel quid chewing and chronic infection with either hepatitis B virus (synergy index, 5.37) or hepatitis C virus (synergy index, 1.66). Moreover, risk on HCC increased as duration of betel quid chewing increased, or amount of betel quid consumed (each *P* for trend < 0.0001). © 2001 Cancer Research Campaign <http://www.bjcancer.com>

**Keywords:** betel quid chewing; hepatocellular carcinoma; hepatitis B virus; hepatitis C virus; risk factor

Hepatocellular carcinoma (HCC) is one of the most common malignant and devastating human tumours in the world (Idilman et al, 1998; DiBisceglie, 1999). Although chronic hepatitis B virus (HBV) and hepatitis C virus (HCV) infection have been implicated as the major risk factors for HCC (Tsai et al, 1996a, 1997a; DiBisceglie, 1999), some HCC occurs in patients without evidence of HBV/HCV infection, suggesting that other environmental or genetic factors, may also be important (Bartsch et al, 1999; DiBisceglie, 1999; Ozturk, 1999). Besides alcohol drinking and cigarette smoking, betel quid chewing is an integral component of the cultural fabric of 10–20% of the human population. It is also a popular habit throughout Taiwan. The cultivation of areca trees and the production of areca nuts increase markedly during the last 3 decades (Ko et al, 1992; Chen and Shaw, 1996). The estimated number of habitual betel quid chewers is around one-tenth of the 20 million inhabitants (Ko et al, 1992). The population of betel quid chewers increased gradually.

The ingredients of betel quid include areca nut (the nut of the *Areca catechu* palm), betel leaf or fruit from *Piper betle*, and red slaked paste. During betel quid chewing, areca nut-derived nitrosamines may methylate and cyanoethylate liver DNA (Prokopczyk et al, 1987), be genotoxic to hepatocytes, and hence produce liver cancer (Bhide et al, 1979; Nishikawa et al, 1992). Areca nut may enhance chemical hepatocarcinogenesis (Bhide et al, 1979; Tanaka et al, 1986). On the other hand, the betel leaf contains high concentrations (15 mg g<sup>-1</sup> fresh weight) of safrole known to be a rodent hepatocarcinogen (Philips, 1994). Moreover, it has been reported that 37.5% of areca nut samples were infested with aflatoxin B1-producing fungus, *Aspergillus flavus* (Raisuddin and Misra, 1991).

Received 18 July 2000

Revised 27 October 2000

Accepted 3 November 2000

Correspondence to: Jung-Fa Tsai, Department of Internal Medicine, Kaohsiung Medical University College of Medicine, 100 Shih-Chuan 1 Rd, Kaohsiung, Taiwan 807, Republic of China

Betel quid chewing may therefore have some carcinogenic and tumour-promoting activity in the liver making it pertinent to assess the possible effects of betel quid chewing on the development of HCC, which is one of the most common prevalent cancers in Taiwan (Tsai et al, 1996a, 1997a). The betel quid hypothesis was tested using the data collected in a case-control study of risk factors for HCC

### MATERIALS AND METHODS

#### Study population

263 consecutive newly diagnosed patients with HCC, 205 males and 58 females, were recruited as the case group from Department of Internal Medicine, Kaohsiung Medical University Hospital during the period from August 1996 to December 1997. HCC was diagnosed by aspiration cytology or biopsy. During the same study period, 263 healthy community residents, who entered the hospital for physical check-up, matched on age ( $\pm 3$  years) and sex, were enrolled as the control group. All controls had normal serum aminotransferase levels and with no space-occupying lesion in the liver, as evidenced by normal abdominal sonography. There was no difference in median age between cases (59 years; range: 29–83 years) and controls (59 years; range: 29–82 years).

#### Structured questionnaire and standardized interview

We designed a structured questionnaire to obtain information on age, sex, educational level, habits of smoking (cigarettes per day and duration of smoking), alcohol drinking (the quantity and duration of drinking, types of alcoholic beverage), betel quid chewing practice (duration of habit, daily amount consumed, type of betel quid ingredients consumed). A habitual betel quid chewer was defined as chewing one quid or more daily for at least one year. A habitual cigarette smoker was defined as smoking one cigarette or more per day for at least one year. A habitual alcohol drinker was defined as drinking alcohol for more than four days a week for at

least one year. All HCC cases and matched controls were interviewed by interviewers trained in study details and questionnaire contents.

### Serological examination

An aliquot of 7 ml blood was collected by vacuum syringe with disposable needle from each study subject. Serum samples separated were aliquoted and kept at minus 70°C until tested. Hepatitis B surface antigen (HBsAg) was tested by radioimmunoassay using commercial kits (Abbott Laboratories, North Chicago, IL). Antibodies to hepatitis C virus (anti-HCV) were detected by second generation ABBOTT HCV EIA (Abbott Laboratories, North Chicago, IL). For anti-HCV, reactive specimens were retested. Only repeatedly reactive specimens were interpreted as anti-HCV positive. Conventional liver function tests were tested by an autoanalyser.

### Statistical analysis

The Mann-Whitney U test was used to compare the difference between medians of continuous variables. The  $\chi^2$  test with Yates' correction was used to compare differences between proportions. Odds ratio (OR) with 95% confidence interval (95% CI) was used to estimate causal relations between risk factors and exposure. Mantel extension test for trend was used to estimate the dose-response relationship among risk factors. A conditional logistic regression analysis was used for multivariate analysis. Adjusted odds ratios and 95% CI were derived from logistic regression coefficients to provide an estimate of the statistical association between a given variable and the disease (HCC) with the other variables held constant. Synergy index was used to estimate the interactive effect between risk factors (Rothman, 1986). To calculate the population-attributable risk for factors significantly associated with HCC development in multivariate analysis, the frequency distribution of these risk factors in the control group was used to represent the proportion of persons exposed to the factor in the general population. If there is additive interaction among these risk factors, the sum of each attributable-risk may exceed 100%. An alpha of 0.05 was used as the indicator of significance.

## RESULTS

### Independent risk factors for HCC

Univariate analysis indicated that betel quid chewing (OR = 4.05, 95% CI, 2.35-7.00), HBsAg-positivity (OR = 6.57, 95% CI,

4.38-9.85), anti-HCV-positivity (OR = 9.98, 95% CI, 5.12-19.88), educational level less than 10 years (OR = 1.63, 95% CI, 1.14-2.34), alcohol drinking (OR = 2.41, 95% CI, 1.48-3.94), and smoking (OR = 1.58, 95% CI, 1.09-2.28) were significant risk factors of HCC. The adjusted ORs for factors such as betel quid chewing, HBsAg-positivity, anti-HCV-positivity, and educational level less than 10 years remained significantly elevated even after multivariate analysis (Table 1). The estimated population-attributable risk was 27.63% (95% CI, 13.45-29.84) for subjects with anti-HCV alone, 46.86% (95% CI, 23.41-40.37) for subjects with HBsAg alone, 5.78% (95% CI, 1.08-9.71) for subjects positive for anti-HCV and HBsAg, 20.19% (95% CI, 9.81-23.78) for all betel quid chewers; and 23.22% (95% CI, 9.28-28.41) for those had educational duration of less than 10 years.

### Interactive effect between betel quid chewing and chronic HBV/HCV infection

As shown in Table 2, using subjects without betel quid chewing and negative for both anti-HCV and HBsAg as a referent group, the risk for HCC increased significantly in subjects with HBV and/or HCV infection. The estimated ORs were found to be higher in betel quid chewers infected with HBV or HCV infection (Table 2).

Table 3 displays the interactive effect between betel quid chewing and HCV infection. By using anti-HCV-negative subjects without chewing betel quid as a referent group, either betel quid chewing or presence of anti-HCV were independent risk factors for HCC. The highest ORs were found in anti-HCV-positive betel quid chewers (Table 3). Calculation of synergy index indicated that there was an additive interaction between betel quid chewing and HCV infection. Similarly, the risk for developing HCC was strongly associated with the presence of HBsAg and chewing betel quid (Table 4). Moreover, HBsAg-positive betel quid chewers had the highest OR, and a synergy index of 5.37. This result indicated an additive interaction between betel quid chewing and HBV infection.

### Characteristics of betel quid chewing in HCC patients and controls

All betel quid chewers chewed areca nut. Chewing with betel leaf or with unripe betel fruit was strongly associated with the risk of HCC (Table 5). The duration of chewing betel quid for more than 20 years is an independent risk factor of HCC development (OR = 13.78, 95% CI, 3.88-51.43). Moreover, the longer the duration of betel quid chewing, the higher the risk of developing HCC ( $P_{\text{for trend}} < 0.0001$ ; Table 5).

Table 1 Univariate and multivariate analyses of risk factors for HCC

Parameters	Cases (n = 263)	Controls (n = 263)	OR (95% CI)	Adjusted OR* (95% CI)
Betel quid chewing	71	22	4.05 (2.35-7.00)	3.49 (1.74-6.96)
HBsAg-positive	171	58	6.57 (4.38-9.85)	16.69 (9.92-28.07)
Anti-HCV-positive	85	12	9.98 (5.12-19.88)	38.57 (18.15-81.96)
Education <10 years	158	126	1.63 (1.14-2.34)	1.71 (1.05-2.78)

HCC, hepatocellular carcinoma; OR, odds ratio; CI, confidence interval; HBsAg, hepatitis B surface antigen; anti-HCV, antibodies to hepatitis C virus. \*Derived from conditional logistic regression analysis after adjusting sex, age, habits of alcohol drinking and smoking, and covariates in the table. Only covariates with significant adjusted odds ratio are shown.

1012  
R

**Table 2** Risk of HCC modified by betel quid chewing, status of anti-HCV and HBsAg in HCC patients compared with matched controls

Betel quid	Status		Cases (n = 263)	Control (n = 263)	Odds ratio (95% CI)
	anti-HCV	HBsAg			
Nonuser	Negative	Negative	19	180	1.0
Nonuser	Negative	Positive	102	50	19.32 (10.42–36.17)
Nonuser	Positive	Negative	55	7	74.43 (27.65–209.70)
Nonuser	Positive	Positive	16	4	37.89 (10.38–151.37)
User	Negative	Negative	7	17	3.90 (1.27–11.67)
User	Negative	Positive	50	4	118.42(35.59–436.95)
User	Positive	Negative	11	1	104.21 (12.61–351.82)
User	Positive	Positive	3	0	— <sup>a</sup>

HCC, hepatocellular carcinoma; OR, odds ratio; CI, confidence interval; HBsAg, hepatitis B surface antigen; anti-HCV, antibodies to hepatitis C virus. <sup>a</sup> uncalculable.

**Table 3** Interactions between betel quid chewing and anti-HCV on risk of HCC

Betel quid chewer	anti-HCV	Cases (n = 263)	Controls (n = 263)	OR* (95% CI)
No	Negative	121	230	1
No	Positive	71	11	12.26 (6.03–25.51)
Yes	Negative	57	21	5.15 (2.89–9.25)
Yes	Positive	14	1	26.61 (3.60–116.58)

HCC, hepatocellular carcinoma; anti-HCV, antibodies to hepatitis C virus; OR, odds ratio; CI, confidence interval. \*Synergy index = 1.66

**Table 4** Interactions between betel quid chewing and HBsAg on risk of HCC

Betel quid chewer	HBsAg	Cases (n = 263)	Controls (n = 263)	OR* (95% CI)
No	Negative	74	187	1
No	Positive	118	54	5.52 (3.55–8.59)
Yes	Negative	18	18	2.52 (1.17–5.42)
Yes	Positive	53	4	33.48 (11.10–72.69)

HCC, hepatocellular carcinoma; HBsAg, hepatitis B surface antigen; OR, odds ratio; CI, confidence interval. \*Synergy index = 5.37

The median value of total amount of betel quid consumed in HCC patients (182 500 quids; range: 73 000–730 000 quids) was higher than that (109 500 quids, range: 10 290–547 500 quids) in controls ( $P = 0.0001$ ). There was an increased risk for developing HCC in subjects consumed more than 100 000 quids (OR = 4.54, 95% CI, 1.40–14.99). There is a positive linear trend between betel quids consumed and the risk for HCC ( $P_{\text{for trend}} < 0.0001$ ; Table 5)

#### Clinical characteristics in HCC patients according to betel quid chewing

As shown in Table 6, there was marginal significance in the median age between patients with betel quid chewing and those without ( $P = 0.058$ ). HCC patients with betel quid chewing were predominantly male ( $P = 0.0001$ ), and tended to be anti-HCV-negative ( $P = 0.008$ ). All 71 habitual betel quid chewers were

**Table 5** Risk of hepatocellular carcinoma based on type of betel quid ingredients, duration and total amount of betel quid consumed

Parameter	Cases	Controls	OR (95% CI)
Type of material in quids			
Non-user	192	241	1.0
Areca-nut with betel leaf	17	6	3.55 (1.28–10.30)
Areca-nut with betel fruit	36	9	5.02 (2.25–11.50)
Mixed	18	7	3.22 (1.24–8.70)
Duration of chewing (years) <sup>a</sup>			
Non-user	192	241	1.0
<20	8	14	0.71 (0.26–1.86)
20–30	27	5	6.77 (2.42–20.46)
>30	36	3	15.06 (4.36–39.09)
Total amounts consumed (quids × 1000) <sup>b</sup>			
Non-user	192	241	1.0
<100	11	10	1.38 (0.53–3.59)
100–199	31	7	5.55 (2.27–14.17)
200–299	15	3	6.27 (1.67–20.74)
>299	14	2	8.78 (1.87–34.01)

<sup>a,b</sup>  $P_{\text{for trend}} < 0.0001$  (Mantel extension test for trend).

**Table 6** Clinical characteristics in patients with hepatocellular carcinoma with regard to betel quid chewing

	Habitual betel quid chewing		
	Yes (n = 71)	No (n = 192)	P value*
Age (years)	56 (29–81) <sup>b</sup>	61 (32–83)	0.05
Educational level	6 (1–16)	9 (1–16)	NS
Male gender	67 (94.36) <sup>c</sup>	138 (71.87)	0.0001
Cirrhosis	71 (100)	142 (73.95)	0.0001
Smoking	51 (71.83)	69 (35.93)	0.0001
Alcohol drinking	32 (45.07)	34 (17.70)	0.0001
HBsAg-positive	53 (74.64)	118 (61.45)	NS
Anti-HCV-positive	14 (19.71)	71 (36.97)	0.008

NS, nonsignificant. \*Mann-Whitney U test was used for comparison of continuous data, whereas  $\chi^2$  test was used for comparison of proportions. <sup>b</sup>Data were expressed as median (ranges). <sup>c</sup>Data were expressed as number (percentage).

cirrhotics ( $P = 0.0001$ ). Betel quid chewers were frequently habitual smokers ( $P = 0.0001$ ) and alcohol drinkers ( $P = 0.0001$ ).

#### DISCUSSION

By using a formal epidemiological approach, this study provides evidence that habitual betel quid chewing is an independent risk factors for HCC. However, the estimated population-attributable risks indicate that chronic HBV/HCV infections are the most important risk factors of HCC in Taiwan (Table 1). Since betel quid chewing has not been shown to be a risk factors of HCC before, it is important to validate that our finding is not due to confounding bias. The bias may result from the control selection, information bias, or by un-controlling confounding factor. According to medical records, our healthy controls were healthy subjects who entered the hospital voluntarily for physical check-up. The prevalence of HBsAg (22.1%) and anti-HCV (4.6%) in our healthy controls was similar to those in volunteer blood donors (Tsai et al, 1997b) or community controls in the same area (Tsai et al, 1993, 1996a, 1996b). The estimated prevalence of current betel

1613  
8

quid chewers in the same community inhabitants was around 6.5% (Ko et al, 1992; Chen and Shaw, 1996). Moreover, the higher the educational level achieved, the lower the likelihood of being a betel quid chewer (Ko et al, 1992). As the population of betel quid chewing in Taiwan has recently increased year by year, the prevalence of habitual betel quid chewing in our controls (8.36%) seemed reasonable. Among our controls, the frequency of betel quid chewing in subjects with educational level less than 10 years was significantly higher than that in those with more educational level (12.69% vs. 4.37%,  $P = 0.024$ ). Moreover, there was no significant difference in the prevalence rates of habitual alcohol drinking and smoking between our controls and those (11% for alcohol and 65.5% for smoking, respectively) in another case-control study (Chen et al, 1991). Based on the information mentioned above, our controls seem to be representative for general population of Taiwan, and make bias unlikely from control selection or under-reporting of life-style habits.

As shown in Tables 3 and 4, although the number of betel quid chewers with either HBV or HCV infection among the controls is small, the OR for HBV- or HCV-infected betel quid chewers seems to be greater than the sum, but lower than the product of the OR for either betel quid chewers alone or subjects with either viral infection alone. Based on a calculation of synergy index, an additive interaction between betel quid chewing and either HBV or HCV infection was deduced (Rothman, 1986). However, there was no multiplicative interaction between betel quid chewing and either HBV or HCV infection on multivariate analysis (data not shown). Taken together, these observations suggest an independent effect and an additive interaction between betel quid chewing and either HBV or HCV infection on the development of HCC.

Both genetic and environmental factors determine individual susceptibility to cancer. Carcinogens derived from betel quid chewing may induce p53 mutation (Wong et al, 1998; Chiang et al, 1999) and over-expression of c-myc protein (Baral et al, 1998) with activated ras oncogene and subsequent over-expression of cell cycle regulatory protein, cyclin D1 (Kuo et al, 1995, 1999). These genetic alterations may have occurred in the process of hepatocarcinogenesis (Idilman et al, 1998; Ozturk, 1999).

Animals with chronic betel quid feeding developed chronic hepatocyte necroinflammation (Sarma et al, 1992) and liver cancer (Bhide et al, 1979; Nishikawa et al, 1992). Although a causal relationship has not been conclusively established, chronic inflammation of the liver appears to be a risk factor for HCC regardless of the underlying aetiology (Tsai et al, 1996a, 1997a; Idilman et al, 1998). Though the mechanism is unknown, episodic necroinflammation has been considered important not only in inducing cirrhosis, but also in promoting transformation and progression to HCC (Idilman et al, 1998). Recent necroinflammation may be a promoting factor that serves as an endogenous cocarcinogen. Inflammatory byproducts, including oxygen-derived free radicals and other reactive oxygen species, may cause cellular or DNA damage that could be involved in hepatocarcinogenesis (Hagen et al, 1994; Shimoda et al, 1994; Farinati et al, 1999). In this study, all HCC patients with habitual betel quid chewing also had cirrhosis (Table 6). Although cirrhosis is a late sequela of chronic HBV/HCV infection, declining liver function and reactive oxygen species induced during chronic betel quid chewing (Liu et al, 1996) may contribute, at least in part, to an additive interaction between betel quid chewing and chronic HBV/HCV infection.

Little is known about the role of the betel leaf in the betel quid carcinogenesis. The saliva of a betel quid chewer contains on

average  $420 \mu\text{mol l}^{-1}$  of safrole (Hwang et al, 1993). Safrole has been classified by the International Agency for Research on Cancer as a group 2B carcinogen (Vainio and Wilbourn, 1992). Experimental study has shown that safrole-induced liver carcinogenesis correlated with the formation of safrole-DNA adducts (Philips, 1994). Recently, safrole-DNA adducts were found in HCC tissue from a heavy betel quid chewer (Liu et al, 2000). The distribution of these adducts was similar to that found in safrole-treated mice: highest in the liver and lower in other tissues. Furthermore, safrole-DNA adduct could not be found in HCC tissue from patients who did not chew betel quid. This information indirectly supports our finding that betel quid chewing is an independent risk factor of HCC. In conclusion, habitual betel quid chewing appears to be an independent risk factor of HCC and an additive interaction between betel quid chewing and chronic HBV/HCV infection.

## ACKNOWLEDGEMENTS

This study was supported in part by the National Science Council of the Republic of China (NSC 85-2331-B-037-084 M14).

## REFERENCES

- Bartsch H, Rojas M, Nair U, Nair J and Alexandrov K (1999) Genetic cancer susceptibility and DNA adducts: studies in smokers, tobacco chewers, and coke oven workers. *Cancer Detect Prev* 23: 445-453
- Baral RN, Patnaik S and Das BR (1998) Co-expression of p53 and c-myc proteins linked with advanced stages of betel- and tobacco-related oral squamous cell carcinomas from eastern India. *Eur J Oral Sci* 106: 907-913
- Bhide SV, Shivapurkar NM, Gothoskar SV and Ranadive KJ (1979) Carcinogenicity of betel nut ingredients: feeding mice with aqueous extract and the polyphenol fraction of betel nut. *Br J Cancer* 40: 922-926
- Chen CJ, Liang KY, Chang AS, Chang YC, Lu SN, Liaw YF, Chang WY, Sheen MC and Lin TM (1991) Effects of hepatitis B virus, alcohol drinking, cigarette smoking and familial tendency on hepatocellular carcinoma. *Hepatology* 13: 398-406
- Chen JW and Shaw JH (1996) A study on betel quid chewing behavior among Kaohsiung residents aged 15 years and above. *J Oral Pathol Med* 25: 140-143
- Chiang CP, Huang JS, Wang JT, Liu BY, Kuo YS, Jahn LJ and Kuo YP (1999) Expression of p53 protein correlates with decreased survival in patients with areca quid chewing and smoking-associated oral squamous cell carcinoma in Taiwan. *J Oral Pathol Med* 28: 72-76
- DiBisceglie AM (1999) Malignant neoplasms of the liver. In: *Schiff's disease of the liver*. 8th edn. Schiff ER, Sorrell MF, Maddrey WC, (eds) pp. 1281-1304. Lippincott-Raven Publishers: Philadelphia
- Farinati F, Cardin R, Degan P, De Maria N, Floyd RA, Van Thiel DH and Naccarato R (1999) Oxidative DNA damage in circulating leukocytes occurs as an early event in chronic HCV infection. *Free Radic Biol Med* 27: 1284-1291
- Hagen TM, Huang S, Curmutte J, Fowler P, Martinez V, Wehr CM, Ames BN and Chisari FV (1994) Extensive oxidative DNA damage in hepatocytes of transgenic mice with chronic active hepatitis destined to develop hepatocellular carcinoma. *Proc Natl Acad Sci USA* 91: 12808-12828
- Hwang LS, Wang CK, Sheu MJ and Kao LS (1993) Phenolic compounds of piper betle flower as flavoring and neuronal activity modulating agents. In *Food phytochemicals for cancer prevention*. Ho CT, Osawa T, Huang MT, Rossen RT (eds) pp. 186-191. American Chemical Society: Washington, DC
- Idilman R, De Maria N, Colantoni A and Van Thiel DH (1998) Pathogenesis of hepatitis B and C-induced hepatocellular carcinoma. *J Viral Hepatitis* 5: 285-299
- Ko YC, Chiang TA, Chang SJ and Hsieh SF (1992) Prevalence of betel quid chewing habit in Taiwan and related sociodemographic factors. *J Oral Pathol Med* 21: 261-264
- Kuo MYP, Chang HH, Hahn LJ, Wang JT and Chiang CP (1995) Elevated ras p21 expression in oral premalignant lesions and squamous cell carcinoma in Taiwan. *J Oral Pathol Med* 24: 255-260
- Kuo MYP, Lin CY, Hahn LJ, Cheng SJ and Chiang CP (1999) Expression of cyclin D1 is correlated with poor prognosis in patients with areca quid

10/14  
R

- chewing-related oral squamous cell carcinomas in Taiwan. *J Oral Pathol Med* 28: 165-169
- Liu TY, Chen CL and Chi CW (1996). Oxidative damage to DNA induced by areca nut extract. *Mutation Res* 367: 25-31
- Liu CJ, Chen CL, Chang KW, Chu CH and Liu TY (2000) Safrole in betel quid may be a risk factor for hepatocellular carcinoma: case-report. *CMAJ* 162: 359-360.
- Nishikawa A, Prokopczyk B, Rivenson A, Zang E and Hoffmann D (1992). A study of betel quid carcinogenesis - VIII. Carcinogenicity of 3 (methylnitrosamino) propionaldehyde in F344 rats. *Carcinogenesis* 13: 369-372
- Ozturk M (1999). Genetic aspects of hepatocellular carcinogenesis. *Semin Liver Dis* 19: 235-242
- Philips DH (1994) DNA adducts derived from safrole, estragole and related compounds, and from benzene and its metabolites. In: *DNA adducts: identification and biological significance*. Hemminki K, Dipple A, Shuker DEG, Kadlubar FF, Segerback D, Bartsch H, (eds) pp. 131-140. International Agency for Research on Cancer Research: Lyon, France
- Prokopczyk B, Rivenson A, Bettinato P, Bertinato P, Brunnemann D and Hoffmann D (1987) 3-(Methylnitrosamino)propionitrile: Occurrence in saliva of betel quid chewers, carcinogenicity, and DNA methylation in F344 rats. *Cancer Res* 47: 467-471
- Raisuddin S and Misra JK (1991) Aflatoxin in betel nut and its control by use of food preservatives. *Food Add Contam* 8: 707-712
- Ramchandani AG, D'Souza AV, Borges AM and Bhisey RA (1998) Evaluation of carcinogenic/co-carcinogenic activity of a common chewing product, pan masala, in mouse skin, stomach and esophagus. *Int J Cancer* 75: 225-232
- Rothman KJ (1986) *Modern epidemiology*, pp. 311-326. Little, Brown & Company: Boston
- Sarna AB, Chakrabarti J, Chakrabarti A, Banerjee TS, Roy D, Mukherjee D and Mukherjee A (1992) Evaluation of pan masala for toxic effects on liver and other organs. *Food Chem Toxicol* 30: 161-163
- Shimoda R, Nagashima M, Sakamoto M, Yamaguchi N, Hirohashi S, Yokota J and Kasai H (1994) Increased formation of oxidative DNA damage, 8-hydroxydeoxyguanosine, in human livers with chronic hepatitis. *Cancer Res* 54: 3171-3172
- Tanaka T, Kuniyasu T, Shima H, Sugie S, Mori H, Takahashi M, and Hirono I (1986) Carcinogenicity of betel quid. III. Enhancement of 4-nitroquinoline-1-oxide- and N-2-fluorenylacetylamine-induced carcinogenesis in rats by subsequent administration of betel nut. *J Natl Cancer Inst* 77: 777-781
- Tsai JF, Chang WY, Jeng JE, Ho MS, Wang LY, Hsieh MY, Chen SC, Chuang WL, Lin ZY and Tsai JH (1993) Hepatitis C virus infection as a risk factor for nonalcoholic cirrhosis in Taiwan. *J Med Virol* 41: 296-300
- Tsai JF, Jeng JE, Ho MS, Chang WY, Hsieh MY, Lin ZY and Tsai JH (1996a) Additive effect-modification of hepatitis B surface antigen and e antigen on the development of hepatocellular carcinoma. *Br J Cancer* 73: 1498-1502
- Tsai JF, Jeng JE, Ho MS, Chang WY, Lin ZY and Tsai JH (1996b). Independent and additive effect modification of hepatitis C and B viruses infection on the development of chronic hepatitis. *J Hepatol* 24: 271-276.
- Tsai JF, Jeng JE, Ho MS, Chang WY, Hsieh MY, Lin ZY and Tsai JH (1997a) Effect of hepatitis C and B virus infection on risk of hepatocellular carcinoma: a prospective study. *Br J Cancer* 76: 968-974
- Tsai JF, Jeng JE, Ho MS, Wang CS, Chang WY, Hsieh MY, Lin Z and Tsai JH (1997b) Serum alanine aminotransferase level in relation to hepatitis B and C virus infections among blood donors. *Liver* 17: 24-29.
- Vainio H and Wilbourn J (1992) Identification of carcinogenesis within the IARC monograph program. *Scand J Work Environ Health* 18 (suppl 1): 64-73
- Wong YK, Liu TY, Chang KW, Lin SC, Chao TW, Li PL and Chang CS (1998) p53 alterations in betel quid- and tobacco-associated oral squamous cell carcinomas from Taiwan. *J Oral Pathol Med* 27: 243-248

10/15  
8

# Safrole in betel quid may be a risk factor for hepatocellular carcinoma: case report

Chung-Ji Liu,<sup>\*</sup> Chiu-Lan Chen,<sup>†</sup> Kuo-Wei Chang,<sup>‡</sup>  
Cheng-Hsin Chu,<sup>§</sup> Tsung-Yun Liu<sup>¶</sup>

Chewing betel quid or the combination of chewing betel quid and smoking cigarettes is associated with an increased risk of oral squamous cell carcinoma.<sup>1</sup> The composition of betel quid varies with geographic location. In Taiwan betel quid is composed of areca nut (*Areca catechu*, an Asian tropical palm), slaked lime, and the inflorescence or leaf of *Piper betle* (an Asian climbing plant). The inflorescence of *Piper betle* contains high concentrations (15 mg/g fresh weight) of safrole, an essential oil used in cosmetics and as a food flavouring. Safrole is classified as a rodent hepatocarcinogen,<sup>2</sup> and chewing betel quid may contribute to human exposure to this compound. The saliva of a person chewing betel quid contains on average 420  $\mu\text{mol/L}$  of safrole.<sup>3</sup>

We describe a case of hepatocellular carcinoma in a Taiwanese man who had chewed betel quid for over 32 years; safrole-DNA adducts, a likely cause of liver carcinogenesis, were found in liver biopsy specimens.

## Case

A 54-year-old man presented to hospital with an oral mass subsequently diagnosed as oral squamous cell carcinoma. His past medical history was unremarkable, and he had worked most of his life as a taxi driver. He admitted to heavy use of betel quid (about 30 betel quids daily over 32 years). In addition he had smoked 1.5 packs of cigarettes daily for the same period. He consumed alcohol only on social occasions and then only in moderate amounts. Physical examination revealed a nontender firm mass in the right upper quadrant of the abdomen. Liver echography and CT revealed a hypervascular tumour mass about 4 cm in diameter located in the lateral aspect of the right hepatic lobe. The results of liver function tests included alanine aminotransferase 32 (normally 5 to 35) U/L, aspartate aminotransferase 28 (normally 5 to 30) U/L, alkaline phosphatase 52 (normally 25 to 100) U/L and  $\alpha$ -fetoprotein 67 (normally less than 6)  $\mu\text{g/L}$ . The patient was not infected with hepatitis B or C virus (positive for antibodies to hepatitis B surface antigen and negative for both hepatitis B surface antigen and hepatitis C surface antigen).

Liver biopsy (Fig. 1) showed classic hepatocellular carcinoma. Using the nucleic acid P1-enrichment version of the <sup>32</sup>P-postlabelling technique,<sup>4</sup> we detected safrole-DNA adducts as a single spot on the autoradiogram (Fig. 2). Similar safrole-DNA adducts were seen in tissue samples from the oral squamous cell carcinoma and in peripheral blood leukocyte

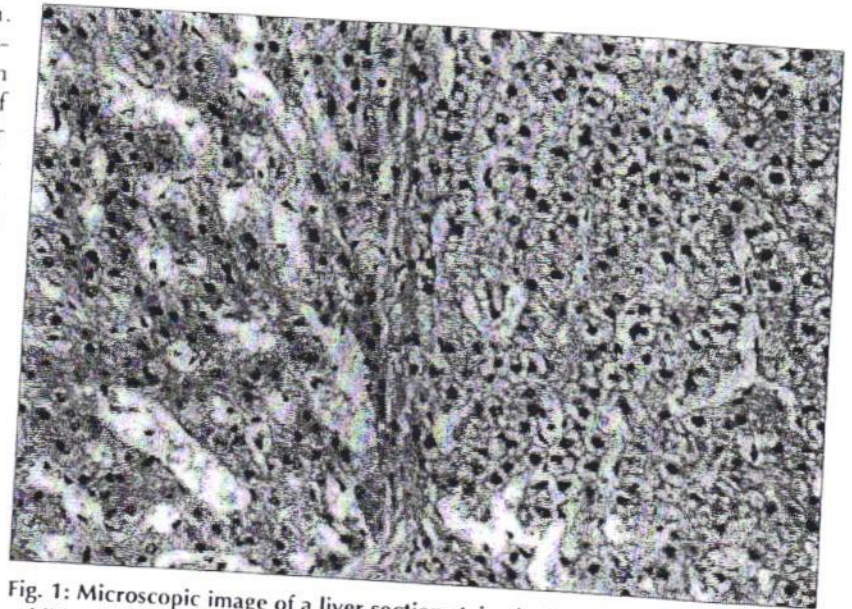

Fig. 1: Microscopic image of a liver section stained with hematoxylin and eosin exhibits well-differentiated hepatocellular carcinoma. The tumour is localized on the left side of the image and is separated from normal liver parenchyma (at right) by a thin layer of fibrous connective tissue. The tumour cells are arranged in a sinusoid pattern. The cytoplasm has a clear or ground-glass appearance. Slight cellular or nuclear pleomorphism is evident.

Review

Synthèse

From <sup>\*</sup>Oral and Maxillofacial Surgery, Dental Department, Mackay Memorial Hospital; <sup>†</sup>Institutes of <sup>‡</sup>Pharmacology and <sup>§</sup>Oral Biology, National Yang-Ming University; the <sup>¶</sup>Gastroenterology Section, Internal Medicine, Mackay Memorial Hospital; and the <sup>¶</sup>Department of Medical Research, Veterans General Hospital—Taipei, Taipei, Taiwan, Republic of China

This article has been peer reviewed.

CMAJ 2000;162(3):359-60

1016

Ⓚ

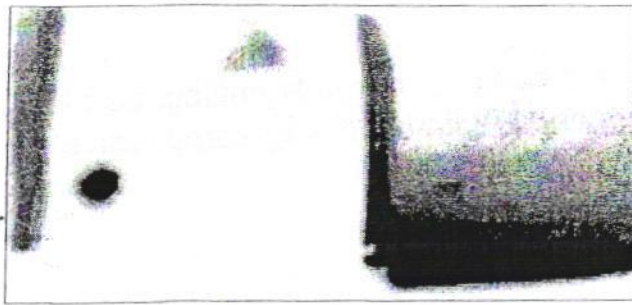

Fig. 2: Autoradiograms of polyethyleneimine-cellulose thin layer chromatography maps of  $^{32}\text{P}$ -labelled digests of DNA (autoradiography performed with Kodak Biomax MR film for 3 hours at  $-70^\circ\text{C}$ ). Left: DNA from HepG2 cells treated with  $400\ \mu\text{mol/L}$  1'-hydroxysafrole for 24 hours. One safrole-DNA adduct visualized as a black spot can be clearly seen in the bottom left corner of this autoradiogram. Right: DNA from liver biopsy specimen. A safrole-DNA adduct can be seen at the bottom left corner of this autoradiogram.

samples.<sup>5</sup> The level of safrole-DNA adduct detected was 22.5 adducts per  $10^8$  nucleotides in liver, 7.1 adducts per  $10^8$  nucleotides in the oral squamous cell carcinoma and 0.8 adducts per  $10^8$  nucleotides in peripheral blood leukocytes. The profile and location of the safrole-DNA adduct were similar to those of adduct found in HepG2 cells treated with 1'-hydroxysafrole; the adduct has been identified as  $N^2$ -(*trans*-isosafole-3'-yl) $2'$ -deoxyguanosine.<sup>5,6</sup> In parallel studies using similar tissues obtained from 6 people who had hepatocellular carcinoma or oral squamous cell carcinoma and who did not chew betel quid, we were unable to detect the safrole-DNA adduct (unpublished data).

## Comments

Carcinogen-DNA adducts represent chemical modifications to the genetic material. They usually arise from the bioactivation of a carcinogen, which then reacts with the DNA. The damage caused by adducts is central to theories of chemical carcinogenesis and is considered a necessary prerequisite for gene mutation and tumour formation.<sup>7</sup> Studies in mice have shown that safrole-induced liver carcinogenesis is correlated with the formation of safrole-DNA adducts.<sup>8</sup> This type of adduct is created through cytochrome-P450-mediated formation of 1'-hydroxysafrole; this compound is sulfonated to become an unstable sulfuric acid ester, which then forms the stable safrole-DNA adducts.<sup>9</sup>

Although these studies do not prove that the safrole in betel quid caused our patient's hepatocellular carcinoma, the findings are suggestive. We found safrole-DNA adducts in the nucleotides of the biopsy specimen from the hepatocellular carcinoma. The distribution of these adducts was similar to that found in safrole-treated mice: highest in the liver and lower in other tissues (the level in peripheral

blood leukocytes was only 1/51 the level in the liver). Our preliminary observations indicate that human tissue harbours the potential to bioactivate the safrole in betel quid to its corresponding DNA adducts, particularly in the liver. This study is the first to show the presence of stable safrole-DNA adducts in hepatocellular carcinoma and oral squamous cell carcinoma in a heavy betel quid user.

Competing interests: None declared.

## References

1. Ko YC, Huang YL, Lee CH, Chen MJ, Lin LM, Tsai CC. Betel quid chewing, cigarette smoking and alcohol consumption related to oral cancer in Taiwan. *J Oral Pathol Med* 1995;24:450-3.
2. International Agency for Research on Cancer. *IARC monographs on the evaluation of carcinogenic risk of chemicals to man, safrole, isosafole, and dihydroxysafrole*. Vol 10. Lyon, France: The Agency; 1976. p. 231-44.
3. Hwang LS, Wang CK, Shen MJ, Kao LS. Phenolic compounds of *Piper betle* flower as flavoring and neuronal activity modulating agents. In: Ho CT, Lee CY, Huang MT, Rossen RT, editors. *Phenolic compounds in food and their effects on health I. Analysis, occurrence, and chemistry*. Washington: American Chemical Society; 1993. p. 186-91.
4. Reddy MV, Randerath K. Nuclease P1-mediated enhancement of sensitivity of  $^{32}\text{P}$ -postlabeling test for structurally diverse DNA adducts. *Carcinogenesis* 1986;7:1543-51.
5. Chen CL, Chi CW, Chang KW, Liu TY. Safrole-like DNA adducts in oral tissue from oral cancer patients with a betel quid chewing history. *Carcinogenesis* 1999;20(12):2331-4.
6. Phillips DH, Miller JA, Miller EC, Adams B. The  $N^2$ -atom of guanine and the  $N^6$ -atom of adenine residues as sites for covalent binding of metabolically activated 1'-hydroxysafrole to mouse-liver DNA in vivo. *Cancer Res* 1981;41:2664-71.
7. Garner RC. The role of DNA adducts in chemical carcinogenesis. *Mutat Res* 1998;402:67-75.
8. Phillips DH. DNA adducts derived from safrole, estragole and related compounds, and from benzene and its metabolites. In: Hemminki K, Dipple A, Shuker DEG, Kadlubar FF, Segerback D, Bartsch H, editors. *DNA adducts: identification and biological significance*. IARC Sci Publ 125. Lyon, France: International Agency for Research on Cancer, 1994. p. 131-40.
9. Miller JA. Sulfonation in chemical carcinogenesis — history and present status. *Chem Biol Interact* 1994;92:329-41.

Reprint requests to: Dr. Tsung-Yun Liu, Department of Medical Research, Veterans General Hospital — Taipei, Shih-Pai, Taipei, 11217, Taiwan, Republic of China; fax 886 2 2875 1562; tyliu@vghtpe.gov.tw

1017  
8

*Cancer Causes Control*. 2003 Apr;14(3):241-50.

## Risk of hepatocellular carcinoma and habits of alcohol drinking, betel quid chewing and cigarette smoking: a cohort of 2416 HBsAg-seropositive and 9421 HBsAg-seronegative male residents in Taiwan.

Wang LY, You SL, Lu SN, Ho HC, Wu MH, Sun CA, Yang HI, Chien-Jen C.

Graduate Institute of Epidemiology, College of Public Health, National Taiwan University, Taipei, Taiwan, ROC.

### Abstract

**OBJECTIVES:** Hepatitis B virus (HBV) is a major cause of hepatocellular carcinoma (HCC) in the world. The specific aim of this study is to assess the associations between the risk of HCC and habits of alcohol drinking, betel quid chewing and cigarette smoking among subjects with and without chronic HBV infection.

**METHODS:** A total of 11,837 male residents in Taiwan were recruited in this community-based cohort study. Hepatitis B surface antigen (HBsAg) and antibody against hepatitis C virus (anti-HCV) in serum were determined by enzyme immunoassay, and the habits of alcohol drinking, betel quid chewing and cigarette smoking were collected through standardized personal interview according to a structured questionnaire. During the follow-up period of 91,885 person-years, 115 incident HCC cases were identified through data linkage with national cancer registry profile. The relative risk (RR) of developing HCC for habits of various substance use and chronic HBV infection were estimated by Cox's proportional hazards regression analyses.

**RESULTS:** Significantly increased HCC risk was observed for seropositives of HBsAg or anti-HCV, alcohol drinkers, betel quid chewers and cigarette smokers. There was a significant dose-response relationship between the risk of HCC and the number of habits of substance use. The highest multivariate-adjusted HCC risk was observed among HBsAg-seropositive substance users (RRs: 17.9-26.9), followed by HBsAg-seropositive non-users (RRs: 13.1-19.2), HBsAg-seronegative substance users (RRs: 1.6-2.7) and HBsAg-seronegative non-users (referent with RR = 1). The multivariate-adjusted relative HCC risks for habits of use of various substances were more profound among HBsAg-seronegatives than HBsAg-seropositive ones.

**CONCLUSION:** Habitual alcohol drinking, betel quid chewing and cigarette smoking are associated with an increased risk of HCC. Abstinence from substance use is important for the prevention of HCC in areas where chronic HBV infection is endemic.

1018  
\*

# Habitual Betel Quid Chewing and Risk for Hepatocellular Carcinoma Complicating Cirrhosis

Jung-Fa Tsai, MD, PhD, Jen-Eing Jeng, MD, Lee-Yea Chuang, PhD, Mei-Shang Ho, MD, Ying-Chin Ko, MD, PhD, Zu-Yau Lin, MD, Min-Yuh Hsieh, MD, Shin-Chern Chen, MD, PhD, Wan-Lung Chuang, MD, PhD, Liang-Yen Wang, MD, Ming-Lung Yu, MD, PhD, and Chia-Yen Dai, MD

**Abstract:** This case-control study aimed to assess the independent and interactive role of habitual betel quid chewing and known risk factors for hepatocellular carcinoma (HCC). Subjects enrolled included 210 pairs of sex- and age-matched cirrhotic patients with HCC, patients with cirrhosis alone, and healthy controls. Information on risk factors was obtained through serologic examination of hepatitis B surface antigen (HBsAg) and antibodies to hepatitis C virus (anti-HCV), and a standardized personal interview with a structured questionnaire. Multivariate analysis indicated that betel quid chewing (odds ratio [OR], 5.81; 95% confidence interval [CI], 2.26–14.94); HBsAg (OR, 37.98; 95% CI, 19.65–73.42); and anti-HCV (OR, 47.23; 95% CI, 18.86–118.25) were independent risk factors for HCC when HCC patients were compared with healthy controls. Using patients with cirrhosis alone as a reference group, multivariate analysis indicated that only betel quid chewing (OR, 1.69; 95% CI, 1.04–2.76) and HBsAg (OR, 1.54; 95% CI, 1.01–2.37) were independent risk factors for HCC. There was an additive interaction between betel quid chewing and the presence of either HBsAg (synergy index, 5.22) or anti-HCV (synergy index, 1.35). Moreover, a higher risk of HCC was associated with a longer duration of betel quid chewing and a larger amount of betel quid consumed (each  $p$  for trend < 0.0001). In conclusion, betel quid chewing is an independent risk factor for cirrhotic HCC. There is an additive interaction between betel quid chewing and chronic hepatitis B and/or hepatitis C virus infection.

(*Medicine* 2004;83:176–187)

From the Department of Internal Medicine, Clinical Laboratory, Biochemistry, and Public Health, Kaohsiung Medical University College of Medicine; the National Health Research Institutes, and the Institute of Biomedical Sciences, Academia Sinica, Taiwan.

Supported in part by a grant from the National Science Council of the Republic of China (NSC 85-2331-B-037-084 M14).

Address reprint requests to: Professor Jung-Fa Tsai, Department of Internal Medicine, Kaohsiung Medical University College of Medicine, Kaohsiung 807, Taiwan. Fax: 886-7-3123955; e-mail: jftsai@cc.kmu.edu.tw.

Copyright © 2004 by Lippincott Williams & Wilkins  
ISSN: 0025-7974/04/8303-0176  
DOI: 10.1097/01.md.0000126971.80227.a4

**Abbreviations:** anti-HCV = antibodies to hepatitis C virus, CI = confidence interval, HBsAg = hepatitis B surface antigen, HBV = hepatitis B virus, HCC = hepatocellular carcinoma, HCV = hepatitis C virus, OR = odds ratio.

## INTRODUCTION

Hepatocellular carcinoma (HCC) is one of the most common and devastating malignant human tumors. HCC accounts for up to 85% of primary liver cancers<sup>36</sup>. In terms of relative frequencies, HCC ranks as the fifth most common cancer in the world, and the second most common cancer of the digestive tract<sup>36</sup>. HCC also ranks sixth in frequency among men and eleventh among women<sup>12,67</sup>. The number of HCC cases has increased in the United States during the past 2 decades, with a shift in the incidence rate toward younger age-groups<sup>36,47</sup>. Similar trends in the incidence of HCC have been observed worldwide<sup>36</sup>. The pathogenesis of HCC is a multistage process with a multifactorial etiology<sup>22–24,36,46,95</sup>. The striking geographic differences in the incidence of HCC suggest that environmental factors frequently contribute to its development<sup>25,36,40,42,47,95,135</sup>.

Although chronic hepatitis B virus (HBV)<sup>36,40,43,67,75,78,91,96,111,135,154,155,159,160,175</sup> and hepatitis C virus (HCV) infection<sup>36,40,43,51,58,67,75,78,96,135,154,155,159,160,173</sup> have been implicated as the major risk factors for HCC, some HCC occurs in patients without evidence of hepatotropic viral infection. These risk factors include nonalcoholic steatohepatitis<sup>15,178</sup>, oral contraceptives<sup>15,36</sup>, aflatoxin<sup>36,43,93</sup>, obesity<sup>100</sup>, parasitic disease<sup>1</sup>, diabetes mellitus<sup>48,59,151</sup>, primary biliary cirrhosis<sup>16</sup>, and some hereditary diseases, such as genetic hemochromatosis<sup>41,43,97</sup>, porphyria cutanea tarda<sup>95</sup>, hereditary tyrosinemia<sup>95</sup>, citrullinemia<sup>36</sup>, Wilson disease<sup>36</sup>, and alpha anti-trypsin deficiency<sup>43</sup>. This information suggests that other environmental factors, genetic alterations<sup>11,22,36,52,66,78,84,96,112,142,153</sup>, or differences in lifestyle habits<sup>37,44,49,62,95,146</sup> may also be important in the development of HCC.

Cirrhosis is the end stage of chronic liver disease irrespective of etiology. There is a close connection between cirrhosis and HCC<sup>36</sup>. Cirrhosis is present in about 80%–90% of patients with HCC<sup>40,42,43,67,73,78,95,96,135,154,156,159,162</sup>. In the majority of HCC patients, cirrhosis precedes HCC development<sup>7,44,62,160</sup>. HCC develops in patients with cirrhosis at an annual rate of 3%–11%<sup>36,37,40,42,43,47,135,160</sup>. Hence, cirrhosis is itself a preneoplastic lesion of HCC. Factors promoting carcinogenesis in cirrhosis include male gender<sup>69</sup>, older age<sup>29</sup>, retinoid deficiency<sup>34</sup>, obesity<sup>100</sup>, and alcohol drinking<sup>146</sup>. The identification of additional risk factors for HCC in cirrhotic patients would be particularly important to optimize preventive medical programs.

Betel quid chewing is an integral component of the cultural fabric for between 10% and 20% of the human population<sup>106,110</sup>. It is also part of traditional Taiwanese culture<sup>27,76,77,86,89,158,176</sup>. The betel quid ingredients vary not only among geographic locations but also among communities and individuals. In Taiwan, the betel quid consists of 2 halves of a fresh areca nut (the nut of the *Areca catechu* palm) sandwiched with a piece of the inflorescence of *Piper betle* (betel leaf) or unripe *Piper betle* fruit (betel fruit), and red slaked lime paste. There is no tobacco in the betel quid.

Both areca nut and betel leaf have genotoxicity<sup>20,21,39,69,70,88,144,166</sup>, mutagenicity<sup>20,39,69,70,166</sup>, and tumorigenicity<sup>10,69,70,124</sup>. The immunosuppressive action of areca nut may facilitate neoplastic development<sup>132,133</sup>. The addition of slaked lime into betel quid ingredients can enhance the formation and release of areca nut-derived nitrosamines and generation of reactive oxygen species during a chewing session<sup>101–103</sup>. These nitrosamines are mutagenic and carcinogenic<sup>5,10,34,70,109,113,118–121,165</sup>. Formation of areca nut-derived nitrosamines-DNA adducts may lead to neoplasia<sup>6,34,55,148</sup>. Areca nut consumption may modulate the function of the hepatic detoxification system and decrease the efficacy of anticarcinogenic substance in the body<sup>137,138,139,140</sup>. Alternatively, betel quid has been shown to contain strong organ-specific carcinogens in laboratory animals<sup>121</sup>. In addition, the combination of betel quid and tobacco has been ranked as a group I carcinogen<sup>163</sup>, that may cause oral<sup>2,4,13,14,25,28,32,56,60,61,70,74,83,128,141,177</sup>, pharyngeal<sup>61</sup>, laryngeal<sup>141</sup>, and esophageal<sup>72,105,116,130,143</sup> cancer. Habitual use of betel quid without tobacco is causally associated with increased risk of oral squamous cell carcinoma<sup>30,31,63,65,77,81,82,90,152</sup> and esophageal cancer<sup>171</sup>. In addition, there are high concentrations of safrole (15 mg/g fresh weight) in the betel leaf<sup>68,115</sup>. The saliva of betel quid chewers contains a high concentration (420 uM) of safrole<sup>25,68,115</sup>. There is increased excretion of safrole-metabolites in the urine of betel quid chewers<sup>19</sup>. Chewing such prepared betel quids may contribute to safrole exposure in human beings. Safrole-DNA adducts have been found in experimental liver carcinogenesis<sup>98,115</sup> and in HCC tissue

from Taiwanese with betel quid chewing<sup>87</sup>. Taken together, betel quid ingredients may have some carcinogenic and tumor-promoting activity in the liver. Thus, we hypothesized that habitual use of these substances might play some role in malignant transformation of hepatocytes.

Taiwan is an area hyperendemic for HBV/HCV infection<sup>22,29,73,154–156,159–162</sup>. Cirrhosis of the liver and HCC have been among the 10 leading causes of death in Taiwan since the 1980s. The mortality rate was 23.45/100,000 for cirrhosis and 28.71/100,000 for HCC in 2001, respectively<sup>38</sup>. To prevent cirrhosis-associated mortality and morbidity, the identification of additional risk factors for HCC in cirrhotic patients is particularly important. We conducted the current case-control study to explore the role of habitual betel quid chewing on the risk for HCC complicating cirrhosis, and to explore the interaction between betel quid chewing and other known risk factors for HCC.

## PATIENTS AND METHODS

### Study Population

Two hundred ten consecutive newly diagnosed cirrhotic patients with HCC and 210 newly diagnosed patients with cirrhosis alone, paired by age ( $\pm 5$  yr) and sex, were enrolled as the case group and the non-HCC control group, respectively. Another 210 healthy community residents, who entered the hospital for physical exams, were recruited as the healthy control group. Each healthy control was pair-matched by sex and age ( $\pm 5$  yr) to a patient with HCC. These subjects were hospitalized or had visited outpatient clinics at Kaohsiung Medical University Hospital from January 1996 to December 1997. HCC was diagnosed by aspiration cytology or biopsy. Cirrhosis was diagnosed by liver biopsy, abdominal sonography, biochemical evidence of parenchymal damage plus endoscopic esophageal or gastric varices<sup>154,155</sup>. Patients with cirrhosis were classified into the 3 Child-Pugh grades based on their clinical status<sup>122</sup>. All the healthy controls had normal serum aminotransferase levels. There was no space-occupying lesion in the liver in any healthy controls or patients with cirrhosis alone, as evidenced by normal abdominal sonography. The study was approved by the Investigation and Ethics Committee of the hospital.

### Structured Questionnaire and Standardized Interview

A structured questionnaire was designed to obtain information on age; sex; educational level; previous history of surgery and blood transfusion; and habits of smoking (number of cigarettes smoked per day and the duration of smoking), alcohol drinking (quantity and duration of drinking, types of alcoholic beverages), and betel quid chewing (daily amount consumed, duration of the habit, type of betel quid consumed). A habitual betel quid chewer was defined as

a person chewing 1 quid or more daily for at least 1 year. A habitual cigarette smoker was defined as a person smoking 1 cigarette or more per day for at least 1 year. A habitual alcohol drinker was defined as a person drinking an alcoholic beverage more than 4 days a week for at least 1 year. All HCC cases and matched controls were interviewed by interviewers trained in study details and questionnaire contents. All interviews were conducted in person using the structured questionnaire.

### Serologic Examination

Hepatitis B surface antigen (HBsAg) and antibodies to hepatitis C virus (anti-HCV) were detected by Ausria-II and second generation Abbott HCV EIA (Abbott Laboratories, North Chicago, IL), respectively. For anti-HCV, reactive specimens were retested. Only repeatedly reactive specimens were interpreted as anti-HCV positive. Conventional liver function tests were measured by an autoanalyzer (Hitachi, Model 736, Japan).

### Statistical Analysis

The Mann-Whitney U test was used to compare the difference between medians of continuous variables. The  $\chi^2$  test with the Yates correction or the Fisher exact test was used to compare differences between proportions when appropriate. Mantel extension test for trend was used to examine the dose-response relationship for the risk estimates of various combinations of risk factors. Odds ratio (OR) with 95% confidence interval (95% CI) was used to estimate causal relations between risk factors and exposure. A conditional logistic regression analysis was used for multivariate analysis. Unconditional stepwise logistic regression analysis was used for estimating risk factors of habitual betel quid chewing in HCC patients. Adjusted OR and 95% CI were derived from logistic regression coefficients to provide an estimate of the statistical association between a given variable and the disease (HCC) with the other variables held constant. Synergy index was used to estimate the interactive effect among risk factors for HCC<sup>128</sup>. To calculate the population-attributable risk for factors significantly associated with HCC development in multivariate analysis, the frequency distribution of these risk factors in the healthy control group was used to represent the proportion of persons exposed to the factor in the general population. Two-tailed p values and 95% CI were given when appropriate. An alpha of 0.05 was used as the indicator of statistical significance.

## RESULTS

### Demographic Characteristics of Cases and Controls

The frequency distribution of sex, age, status of HBsAg and anti-HCV, and Child-Pugh grades of the study

population is shown in Table 1. There was no statistical difference in the sex distribution and median age among the 3 groups. More than 80% of cases and controls were between 40 and 69 years old (data not shown). The prevalence of HBsAg (or anti-HCV) in the healthy control group was significantly lower than that in patients with cirrhosis alone or HCC patients (each  $p = 0.0001$ , respectively). There was no significant difference in the prevalence of HBsAg or anti-HCV between HCC patients and patients with cirrhosis alone. At least 1 marker of HBsAg or anti-HCV was found in 89% of patients with cirrhosis alone and 94% of HCC patients. Compared to patients with cirrhosis alone, HCC patients had a higher prevalence of being Child-Pugh grade B (37.61% vs. 21.90%,  $p = 0.0001$ ) and a lower prevalence of being Child-Pugh grade C (10.95% vs. 19.04%,  $p = 0.014$ ), respectively (see Table 1).

Habitual betel quid chewing was found in 11 (5.23%) healthy controls, 34 (16.19%) patients with cirrhosis alone, and 52 (24.76%) patients with HCC.

In healthy controls, the frequency of being a habitual alcohol drinker was higher in betel quid chewers (45.45%) than in subjects who were not betel quid chewers (9.54%,  $p = 0.001$ ). Such a trend was also found in patients with cirrhosis alone (67.64% vs. 19.31%,  $p = 0.0001$ ), and in patients with HCC (48.1% vs. 17.1%,  $p = 0.0001$ ). Compared to subjects who were not betel quid chewers, betel quid chewers had a higher frequency of being a smoker in healthy controls (90.91% vs. 33.16%,  $p = 0.0002$ ), in patients with cirrhosis alone (91.17% vs. 37.50%,  $p = 0.0001$ ), and in patients with HCC (76.9% vs. 38.6%,  $p = 0.001$ ).

TABLE 1. Patient Characteristics

	Patients With Cirrhosis With HCC (n = 210)	Patients With Cirrhosis Without HCC (n = 210)	Healthy Controls (n = 210)
Sex (M/F)	170:40	170:40	170:40
Median age (yr) (range)	58 (38–82)	57 (36–82)	58 (38–83)
HBsAg/anti-HCV			
Negative/negative	12	23	165
Negative/positive	40	48	6
Positive/negative	141	127	36
Positive/positive	17	12	
Child-Pugh grade			
A	108	124	–
B	79*	46*	–
C	23 <sup>†</sup>	40 <sup>†</sup>	–

Abbreviations: HCC = hepatocellular carcinoma; HBsAg = hepatitis B surface antigen; anti-HCV = antibodies to hepatitis C virus.

\* $p = 0.0001$  (Fisher exact test).

<sup>†</sup> $p = 0.014$  (Fisher exact test).

1021

Betel quid chewers without chronic HBV/HCV infection were found in 8 healthy controls, 5 patients with cirrhosis alone, and 4 patients with HCC. Among these subjects, habitual smokers were found in 1/8 (87.5%) healthy controls, 4/5 (80%) patients with cirrhosis alone, and 4/4 (100%) patients with HCC. The frequency of being a habitual alcohol drinker in these subjects was noted in 2/8 (25%) healthy controls, 3/5 (60%) patients with cirrhosis alone, and 3/4 (75%) patients with HCC.

### Independent Risk Factors for HCC by Univariate and Multivariate Analyses

The frequency of habitual betel quid chewing in healthy controls was significantly lower than that in patients with cirrhosis alone ( $p = 0.0001$ ) or in patients with HCC ( $p = 0.0001$ ). The prevalence of habitual betel quid chewing in HCC patients was higher than that in patients with cirrhosis alone (OR, 1.70; 95% CI, 1.02–2.84;  $p = 0.039$ ).

Using healthy controls as a reference group, univariate analysis indicated that betel quid chewing, HBsAg-positivity, anti-HCV-positivity, smoking, alcohol drinking, low education level (<10 yr), and history of previous blood transfusion were significant risk factors (Table 2), whereas history of previous surgery and older age (>50 yr) were not. Multivariate analysis indicated that only betel quid chewing, HBsAg-positivity, and anti-HCV-positivity were independent risk factors for HCC (Table 3). The estimated population-attributable risk was 17.52% for subjects with anti-HCV alone, 57.92% for subjects with HBsAg alone, 7.10% for subjects positive for anti-HCV and HBsAg, and 20.10% for betel quid chewers, respectively.

To adjust the possible confounding effect of cirrhosis on risk of HCC, we compared cirrhotic patients with HCC to patients with cirrhosis alone by multivariate analysis. The result indicated that betel quid chewing (OR, 1.69; 95% CI, 1.04–2.76) and HBsAg-positivity (OR, 1.54; 95% CI,

TABLE 2. Univariate Analysis of Risk Factors for HCC, Comparing HCC Patients with Healthy Controls

Risk Factor	Cases (n = 210) No. (%)	Controls (n = 210) No. (%)	Odds Ratio (95% CI)
Betel quid chewing	52 (24.8)	11 (5.2)	5.94 (3.01–11.79)
HBsAg	158 (75.2)	39 (18.6)	13.32 (8.34–21.27)
Anti-HCV	57 (27.1)	9 (4.3)	8.32 (3.99–17.33)
Education <10 yr	120 (57.1)	97 (46.2)	1.55 (1.03–2.32)
Alcohol drinking	52 (24.8)	24 (11.4)	2.55 (1.50–4.32)
Smoking	101 (48.1)	76 (36.2)	1.63 (1.10–2.41)
Surgery	81 (38.5)	74 (35.2)	1.17 (0.78–1.74)
Blood transfusion	43 (20.4)	22 (10.5)	2.22 (1.27–3.87)

Abbreviations: See Table 1. CI = confidence interval.

TABLE 3. Multivariate Analysis of Risk Factors for HCC, Comparing Cirrhotic HCC Patients with Healthy Controls\*

Variable	Coefficient	SE	p Value	Odds Ratio (95% CI)
Betel quid chewing	1.76	0.48	0.0001	5.81 (2.26–14.94)
HBsAg	3.63	0.33	0.0001	37.98 (19.65–73.42)
Anti-HCV	3.85	0.46	0.0001	47.23 (18.86–118.25)

Abbreviations: See previous tables. SE = standard error.  
\*Dependent variable: presence of HCC. Independent variables: sex, age >50 yr, HBsAg, anti-HCV, betel quid chewing, educational level <10 yr, alcohol drinking, and smoking.

1.01–2.37) were independent risk factors for cirrhotic HCC (Table 4).

### Interactive Effect of Betel Quid Chewing and Chronic HBV/HCV Infection on Risk of HCC

As shown in Table 5, using betel quid nonusers without chronic HBV/HCV infection as a reference group, the risk for HCC increased significantly in subjects with HBsAg alone or subjects with anti-HCV alone, or in patients co-infected with HBV/HCV infection. It is noteworthy that patients in the group with betel quid chewing alone also had a significantly higher risk for developing HCC (OR, 9.81; 95% CI, 1.97–48.04). The risk for developing HCC in habitual betel quid chewers with either HBV or HCV infection was significantly higher than in those without HBV/HCV infection ( $p = 0.0001$  and  $p = 0.024$ , respectively; Fisher exact test).

Table 6 displays the interactive effect between betel quid chewing and HCV infection. By using anti-HCV-negative subjects who did not chew betel quid as a reference group, either betel quid chewing or presence of anti-HCV was an independent risk factor for HCC. The highest OR was found in anti-HCV-positive betel quid chewers. Calculation of synergy index indicated that there was an additive

TABLE 4. Multivariate Analysis of Risk Factors for HCC, Comparing Cirrhotic Patients with HCC to Patients with Cirrhosis Alone\*

Variable	Coefficient	SE	p Value	Odds Ratio (95% CI)
Betel quid chewing	0.53	0.24	0.032	1.69 (1.04–2.76)
HBsAg	0.43	0.21	0.045	1.54 (1.01–2.37)

Abbreviations: See previous tables.  
\*Dependent variable: presence of HCC. Independent variables: sex, age >50 yr, HBsAg, anti-HCV, betel quid chewing, educational level <10 yr, alcohol drinking, and smoking.

1022

**TABLE 5. Risk for HCC Modified by Betel Quid Chewing, Status of Anti-HCV, and HBsAg in HCC Patients Compared with Healthy Controls**

Betel Quid Status	Anti-HCV	HBsAg	No. of Cases (n = 210)	No. of Controls (n = 210)	Odds Ratio (95% CI)
Nonuser	Negative	Negative	8	157	1.0
Nonuser	Negative	Positive	105	34	60.60 (25.57–149.00)
Nonuser	Positive	Negative	33	5	129.52 (35.50–518.48)
Nonuser	Positive	Positive	12	3	78.50 (15.86–216.27)
User	Negative	Negative	4	8	9.81 (1.97–48.04)* <sup>†</sup>
User	Negative	Positive	36	2	353.25 (64.33–928.00)*
User	Positive	Negative	7	1	137.37 (13.69–499.88) <sup>‡</sup>
User	Positive	Positive	5	1	

Abbreviations: See previous tables.

\**p* = 0.0001 (Fisher exact test).

<sup>†</sup>*p* = 0.024 (Fisher exact test).

<sup>‡</sup>Uncalculable.

interaction between betel quid chewing and HCV infection. Similarly, the risk for developing HCC was strongly associated with the presence of HBsAg and chewing betel quid (Table 7). Moreover, HBsAg-positive betel quid chewers had the highest OR, and a synergy index of 5.22. These results indicated an additive interaction between betel quid chewing and chronic HBV/HCV infection on risk of HCC. However, there was no multiplicative interaction between betel quid chewing and chronic HBV/HCV infection on multivariate analysis (data not shown). Taken together, the interaction between betel quid chewing and HBV/HCV infection was greater than the sum but lower than the product of the ORs for either betel quid chewing alone or subjects with either HBV/HCV infection alone.

### Characteristics of Betel Quid Chewing in HCC Patients and Healthy Controls

Betel quid chewing with either betel leaf or with unripe betel fruit was strongly associated with increased risk for developing HCC (Table 8). Chewing betel quid for more

than 20 years was an independent risk factor for HCC (OR, 14.79; 95% CI, 4.97–34.45). Moreover, the longer the duration of betel quid chewing, the higher the risk for developing HCC (*p*<sub>for trend</sub> < 0.0001; see Table 8).

The median value for total amount of betelquid consumed at diagnosis of cancer in HCC patients was significantly higher than that in healthy controls (data not shown). There was an increased risk for developing HCC in subjects who consumed more than 100,000 quid (OR, 10.32; 95% CI, 3.79–30.47). There was a positive linear trend between total betel quid consumed and the risk for HCC (*p*<sub>for trend</sub> < 0.0001; see Table 8).

### Clinical Characteristics in HCC Patients by Betel Quid Chewing Status

As shown in Table 9, univariate analysis indicated that HCC patients who chewed betel quids were predominantly male (OR, 16.71; 95% CI, 2.36–83.87), habitual smokers (OR, 5.30; 95% CI, 2.57–10.89), habitual alcohol drinkers (OR, 4.49; 95% CI, 2.26–8.90), and tended to be Child-Pugh grade B or C cirrhotics (OR, 2.01; 95% CI, 1.06–3.81). Multivariate analysis indicated that male gender (OR, 10.93; 95% CI, 1.35–88.30), habitual alcohol drinking (OR, 2.92; 95% CI, 1.34–6.34), and habitual smoking (OR, 2.82; 95% CI, 1.26–6.32) were independent risk factors for habitual betel quid chewing.

### DISCUSSION

Our results indicated that there was an association between habitual betel quid chewing and risk for HCC complicating cirrhosis (see Tables 2 and 3). After controlling the possible confounding effects of cirrhosis on the risk of HCC, habitual betel quid chewing was still an independent risk factor for HCC (see Table 4). The current study indicates that lifestyle differences contribute to the risk for HCC. As

**TABLE 6. Interaction Between Hepatitis C Virus Infection and Betel Quid Chewing on Risk for HCC**

Betel Quid Chewing	Anti-HCV	No. of Cases (n = 210)	No. of Healthy controls (n = 210)	Odds Ratio* (95% CI)
No	Negative	113	191	1.0
No	Positive	45	8	9.50 (4.12–22.70)
Yes	Negative	40	10	6.76 (3.10–15.05)
Yes	Positive	12	1	20.28 (2.69–100.16)

Abbreviations: See previous tables.

\*Synergy index = 1.35.

TABLE 7. Interaction Between Hepatitis B Virus Infection and Betel Quid Chewing on Risk for HCC

Betel Quid Chewing	HBsAg	No. of Cases (n = 210)	No. of Healthy Controls (n = 210)	Odds Ratio* (95% CI)
No	Negative	41	162	1.0
No	Positive	117	37	12.49 (7.32–21.40)
Yes	Negative	11	9	4.82 (1.71–13.72)
Yes	Positive	41	2	81.00 (18.02–204.13)

Abbreviations: See previous tables.  
\*Synergy index = 5.22.

shown in Table 5, the risk for HCC in chronic HBV or HCV infection alone was significantly higher than that in betel quid chewing alone. By calculating population-attributable risks, betel quid chewing was less strongly associated with HCC than either HBV or HCV infection. However, it did positively interact with the presence of hepatitis B or hepatitis C, as evidenced by calculation of synergy index (see Tables 6 and 7). These observations suggest an independent effect and an additive interaction between betel quid chewing and chronic HBV/HCV infection. However, among betel quid chewers without HBV/HCV infection, the

TABLE 8. Risk for HCC Based on Type of Betel Quid Ingredients, Duration, and Amount of Betel Quids Consumed

Type of betel quid ingredients*	No. of Cases	No. of Healthy Controls	Odds Ratio (95% CI)
Nonuser	158	199	1.0
Areca nut with betel leaf	24	4	7.55 (2.42–20.18)
Areca nut with betel fruit	13	3	5.45 (1.42–19.15)
Mixed	15	4	4.72 (1.43–17.20)
Duration of chewing (yr)*			
Nonuser	158	199	1.0
<20	5	7	0.89 (0.24–3.22)
20–30	32	3	13.43 (9.84–36.05)
>30	15	1	18.89 (2.58–92.44)
Total amount consumed (quids × 1000)*			
Nonuser	158	199	1.0
<100	11	6	2.30 (0.76–7.18)
100–200	20	2	12.59 (2.78–49.11)
>200	17	3	7.13 (1.92–22.73)

\**P* for trend < 0.0001 (Mantel extension test for trend).

TABLE 9. Clinical Characteristics in Patients with HCC, by Betel Quid Chewing Status

	Habitual Betel Quid Chewing		p Value*
	Yes (n = 52) No. (%)	No (n = 158) No. (%)	
Age >50 yr	44 (84.6)	121 (76.6)	NS
Male gender <sup>†</sup>	51 (98.1)	119 (75.3)	0.0001
Education <10 yr	30 (57.7)	90 (57.0)	NS
Smoking <sup>†</sup>	40 (76.9)	61 (38.6)	0.0001
Alcohol drinking <sup>†</sup>	25 (48.1)	27 (17.1)	0.0001
Child-Pugh B/C	32 (61.5)	70 (44.3)	0.038
HBsAg positive	41 (78.8)	117 (74.1)	NS
Anti-HCV positive	12 (23.1)	45 (28.5)	NS

Abbreviations: See previous tables. NS = not significant.  
\*The  $\chi^2$  test with Yates correction was used to compare proportions.  
<sup>†</sup>Stepwise logistic regression analysis indicated that male gender (OR, 10.93; 95% CI, 1.35–88.30), alcohol drinking (OR, 2.92; 95% CI, 1.34–6.34), and smoking (OR, 2.82; 95% CI, 1.26–6.32) were independent risk factors for betel quid chewing.

association between betel quid chewing and HCC might not be strong (see Table 5). Unless a larger sample size is studied, betel quid chewing cannot be claimed as a risk factor for cirrhotic HCC in subjects without chronic viral hepatitis.

The pathogenic mechanisms for betel quid-induced hepatic carcinogenesis remain largely unknown. Areca nut-derived nitrosamines may methylate and cyanoethylate liver DNA<sup>118</sup>, may be genotoxic to hepatocytes<sup>168</sup>, and hence produce HCC<sup>10,109</sup>. Areca nut may enhance chemical hepatocarcinogenesis<sup>92,115,118,139,149</sup>. Rats given a vitamin A-deficient diet mixed with areca nut may produce altered liver cell foci that are regarded as precursors for liver tumors<sup>150</sup>.

Safrole is the major component of betel leaf. The role of betel leaf in betel quid-induced hepatic carcinogenesis may be related to safrole. It is a known rodent hepatocarcinogen, yet its carcinogenicity in humans is largely undetermined. Safrole has been classified by the International Agency for Research on Cancer as a group 2B carcinogen<sup>163</sup>. Experimental study has shown that safrole-induced liver carcinogenesis correlated with the formation of safrole-DNA adducts<sup>92,115</sup>. Safrole-DNA adducts have been detected in high frequency of cancer tissues from Taiwanese HCC patients<sup>87</sup> and oral cancer patients with a betel quid chewing history<sup>25,63</sup>. Furthermore, safrole-DNA adduct could not be found in HCC tissue from patients who did not chew betel quid<sup>87</sup>.

Carcinogens derived from betel quid chewing may include induction of p53 mutation<sup>31,32,36,60,63,74,170</sup>, overexpression of p53 gene<sup>98,174</sup>, murine double minute gene 2 (inhibition of the p53 tumor suppressor protein)<sup>65</sup>, abnormal

1024

expression of cyclin D1 and other cell cycle regulatory proteins<sup>53,70,80</sup>, aberrant expression of the cell surface adhesion molecule<sup>80</sup>, overexpression of c-myc protein<sup>14</sup>, and accumulation of mitochondria DNA deletions<sup>85</sup>. Association between mutations and overexpression of ras oncogene are important in the oncogenesis of betel quid<sup>79,81,82,110</sup>. Activated ras oncogene may induce cyclin D1 overexpression<sup>53</sup>. These alterations have been found to contribute to human liver carcinogenesis<sup>10,33,94,96,108,112,129,134,147,179</sup>.

Researchers have observed that 37.5% of betel nut samples were infested with the aflatoxin-producing fungus, *Aspergillus flavus*<sup>123</sup>. Aflatoxin B1 is the most common aflatoxin contaminant and the most hepatocarcinogenic<sup>9,24,36,93,96,125,126,167,169</sup>. Habitual betel quid chewing may be a source of aflatoxin B1 ingestion in humans. Exposure to environmental aflatoxin B1 has long been implicated as a risk factor for HCC. Ecologic studies conducted in Africa and southeast Asia had revealed a strong correlation between the contamination of foodstuffs by aflatoxins and the risk for HCC<sup>24,169</sup>. The serum level of aflatoxin B1-albumin adducts is considered the most appropriate biomarker for the assessment of a relatively long-term cumulative exposure to aflatoxin B1. Aflatoxin is a causative agent for HCC and substantially amplifies the risk created by HBV infection<sup>36</sup>. Nested case-control studies performed in Taiwan showed a significant association between aflatoxin B1-albumin adducts in serum and HCC risk<sup>167</sup>. Whether this observation relates to oncogenesis of HCC in betel quid chewers requires further molecular investigation.

Habitual betel quid chewing causes chronic inflammation of the oral mucosa (oral submucosal fibrosis) that is a precancer lesion of oral squamous cell carcinoma<sup>3,17,164</sup>. It is noteworthy that animals fed betel quids in the long term developed both chronic hepatocyte necroinflammation<sup>131</sup> and liver cancer<sup>10,109</sup>. In the evolution of chronic liver disease, episodic necroinflammation has been considered important not only in inducing cirrhosis, but also in promoting transformation and progression to HCC<sup>42,78,96,117,135</sup>. Recent necroinflammation may be a promoting factor that serves as an endogenous cocarcinogen<sup>42,96,117</sup>. Inflammatory by-products, including oxygen-derived free radicals and other reactive oxygen species, may cause oxidative DNA damage, which may increase the risk for genomic alterations causing hepatic mutagenesis and carcinogenesis<sup>18,50,99,144,145,172</sup>.

It is noteworthy that both betel quid chewing itself<sup>26,70,88,101,102,104,152</sup> and chronic HBV/HCV infections<sup>50,54,57,114,136</sup> produce reactive oxygen species. Studies have suggested that betel quid-generated reactive oxygen species are among the contributing factors for oral carcinogenesis<sup>26,70,88,101,102,104,144</sup>. Reactive oxygen species are formed in the human oral cavity during betel quid chewing. They may cause oxidative DNA damage to the surrounding

tissues<sup>26,70,88,101,102,104</sup>. Swallowing saliva during a betel quid chewing session may result in absorption of areca nut-derived nitrosamines and reactive oxygen species in the upper digestive tract<sup>101-103</sup>; these may contribute to the increased risk for pharyngeal<sup>61</sup>, laryngeal<sup>141</sup>, and esophageal cancer<sup>72,105,116,130,143,171</sup>, and HCC.

In our HCC patients with betel quid chewing, there was a higher frequency of being classified as Child-Pugh grade B or grade C (see Table 7). The continuing repetitive process of chronic liver cell injury, inflammation, and hepatocyte regeneration can lead to focal uncontrolled liver cell growth and eventual malignant transformation<sup>57,74,96</sup>. This information may explain, at least in part, the increased risk of betel quid chewing on the development of HCC. The decreased liver function and reactive oxygen species induced during habitual betel quid chewing may contribute, at least in part, to the additive interaction between betel quid chewing and chronic HBV/HCV infection (see Table 3).

The habits of alcohol drinking and cigarette smoking, and their interactions, have been documented as risk factors for the development of cirrhosis and HCC<sup>22-24,36,59</sup>. As shown in Table 9, betel quid chewers were usually also habitual smokers and alcohol drinkers. Regardless of patient population (healthy subjects or patients with cancer), the same association has been found in several studies in Taiwan<sup>27,76,77,86,89,158,176</sup>. It is noteworthy that after adjusting for cirrhosis and other confounding factors, the current study indicates that habitual betel quid chewing and chronic HBV infection were the independent risk factors for HCC complicating cirrhosis (see Table 4). The interactive effects of chronic HBV infection and the habits of cigarette smoking and alcohol drinking have been reported previously in Taiwan<sup>23</sup>. Hence, the association of habitual betel quid chewing with HCC may result from the association of betel quid chewing with cigarette smoking and drinking alcohol.

In conclusion, both betel quid chewing and chronic HBV/HCV infection are independent risk factors for HCC complicating cirrhosis. There is an additive interaction between betel quid chewing and chronic HBV/HCV infection. Our study points out the possibility of preventing HCC by eliminating or reducing exposure to risk factors via lifestyle changes.

## REFERENCES

1. Abdel-Rahim AY. Parasitic infections and hepatic neoplasia. *Dig Dis*. 2001;19:288-291.
2. Ahmed S, Rahman A, Hull S. Use of betel quid and cigarettes among Bangladeshi patients in an inner-city practice: Prevalence and knowledge of health effects. *Br J Gen Pract*. 1997;47:431-434.
3. Babu S, Bhat RV, Kumar PU, Sesikaran B, Rao KV, Aruna P, Reddy PR. A comparative clinicopathological study of oral submucous fibrosis in habitual chewers of pan masala and betel quid. *J Toxicol Clin Toxicol*. 1996;34:317-322.
4. Balaram P, Sridhar H, Rajkumar T, Vaccarella S, Herrero R, Nandakumar A, Ravichandran K, Ramdas K, Sankaranarayanan R.

- Gajalakshmi V, Munoz N, Franceschi S. Oral cancer in southern India: The influence of smoking, drinking, paan-chewing and oral hygiene. *Int J Cancer*. 2002;98:440-445.
5. Bartsch H. N-nitroso compounds and human cancer: Where do we stand? *IARC Sci Publ*. 1991;105:1-10.
  6. Bartsch H, Rojas M, Nair U, Nair J, Alexandrov K. Genetic cancer susceptibility and DNA adducts: Studies in smokers, tobacco chewers, and coke oven workers. *Cancer Detect Prev*. 1999;23:445-453.
  7. Bennett GL, Krinsky GA, Abitbol RJ, Kim SY, Theise ND, Teperman LW. Sonographic detection of hepatocellular carcinoma and dysplastic nodules in cirrhosis: Correlation of pretransplantation sonography and liver explant pathology in 200 patients. *AJR Am J Roentgenol*. 2002;179:75-80.
  8. Bergsland EK. Molecular mechanisms underlying the development of hepatocellular carcinoma. *Semin Oncol*. 2001;28:521-531.
  9. Bhat RV. Aflatoxin and liver injury. *Trop Gastroenterol*. 1996;17:153-160.
  10. Bhide SV, Shivapurkar NM, Gothoskar SV, Ranadive KJ. Carcinogenicity of betel nut ingredients: Feeding mice with aqueous extract and the polyphenol fraction of betel nut. *Br J Cancer*. 1979;40:922-926.
  11. Bluteau O, Beaudoin JC, Pasturaud P, Belghiti J, Franco D, Bioulac-Sage P, Laurent-Puig P, Zucman-Rossi J. Specific association between alcohol intake, high grade of differentiation and 4q34-q35 deletions in hepatocellular carcinomas identified by high resolution allelotyping. *Oncogene*. 2002;21:1225-1232.
  12. Bosch FX. Global epidemiology of hepatocellular carcinoma. In: Okuda K, Tabor E, eds. *Liver Cancer*. New York: Churchill Livingstone; 1997:13-28.
  13. Boyle P, Macfarlane GJ, Maisonneuve P, Zheng T, Scully C, Tedesco B. Epidemiology of mouth cancer in 1989: A review. *J R Soc Med*. 1990;83:724-730.
  14. Brai RN, Patnaik S, Das BR. Co-expression of p53 and c-myc proteins linked with advanced stages of betel- and tobacco-related oral squamous cell carcinomas from eastern India. *Eur J Oral Sci*. 1998;106:907-913.
  15. Bugianesi E, Leone N, Vanni E, Marchesini G, Brunello F, Carucci P, Musso A, De Paolis P, Capussotti L, Salizzoni M, Rizzetto M. Expanding the natural history of nonalcoholic steatohepatitis: From cryptogenic cirrhosis to hepatocellular carcinoma. *Gastroenterology*. 2002;123:134-140.
  16. Caballeria L, Pares A, Castells A, Gines A, Bru C, Rodes J. Hepatocellular carcinoma in primary biliary cirrhosis: Similar incidence to that in hepatitis C virus-related cirrhosis. *Am J Gastroenterol*. 2001;96:1160-1163.
  17. Celik N, Wei FC, Chang YM, Yang WG, Chen DJ, Tsai CY. Squamous cell carcinoma of the oral mucosa after release of submucous fibrosis and bilateral small radial forearm flap reconstruction. *Plast Reconstr Surg*. 2002;110:34-38.
  18. Cerutti PA. Prooxidant states and tumor promotion. *Science*. 1985;227:375-381.
  19. Chang MJ, Ko CY, Lin RF, Hsieh LL. Biological monitoring of environment exposure to safrole and the Taiwanese betel quid chewing. *Arch Environ Contam Toxicol*. 2002;43:432-437.
  20. Chang YC, Tai KW, Cheng MH, Chou LSS, Chou MY. Cytotoxic and non-genotoxic effects of arecoline on human buccal fibroblasts in vitro. *J Oral Pathol Med*. 1998;27:68-71.
  21. Chang YC, Tai KW, Chou MY, Tseng TH. Synergistic effects of peroxynitrite on arecoline-induced cytotoxicity in human buccal mucosal fibroblasts. *Toxicol Lett*. 2000;118:61-68.
  22. Chen CJ, Chen DS. Interaction of hepatitis B virus, chemical carcinogen, and genetic susceptibility: Multistage hepatocarcinogenesis with multifactorial etiology. *Hepatology*. 2002;36:1046-1049.
  23. Chen CJ, Liang KY, Chang AS, Chang YC, Lu SN, Liaw YF, Chang WY, Sheen MC, Lin TM. Effects of hepatitis B virus, alcohol drinking, cigarette smoking and familial tendency on hepatocellular carcinoma. *Hepatology*. 1991;13:398-406.
  24. Chen CJ, Yu MW, Liaw YF. Epidemiology and multifactorial etiology of hepatocellular carcinoma. *J Gastroenterol Hepatol*. 1997;12:S294-S308.
  25. Chen CL, Chi CW, Chang KW, Liu TY. Safrole-like DNA adducts in oral tissue from oral cancer patients with a betel quid chewing history. *Carcinogenesis*. 1999;20:2331-2334.
  26. Chen CL, Chi CW, Liu TY. Hydroxyl radical formation and oxidativ DNA damage induced by areca quid in vivo. *J Toxicol Environ Heal A*. 2002;65:327-336.
  27. Chen JW, Shaw JH. A study on betel quid chewing behavior among Kaohsiung residents aged 15 years and above. *J Oral Pathol Med*. 1996;25:140-143.
  28. Chen PC, Kuo C, Pan CC, Chou MY. Risk of oral cancer associated with human papillomavirus infection, betel quid chewing, and cigarette smoking in Taiwan—an integrated molecular and epidemiological study of 58 cases. *J Oral Pathol Med*. 2002;31:317-322.
  29. Chen TH, Chen CJ, Yen MF, Lu SN, Sun CA, Huang GT, Yang PM, Lee HS, Duffy SW. Ultrasound screening and risk factors for death from hepatocellular carcinoma in a high risk group in Taiwan. *Int J Cancer*. 2002;98:257-261.
  30. Chen YK, Huang LM, Lin LM, Lin CC. Primary oral squamous cell carcinoma: An analysis of 103 cases in southern Taiwan. *Oral Oncol*. 1999;35:173-179.
  31. Chiang CP, Huang JS, Wang JT, Liu BY, Kuo YS, Jahn LJ and Kuo YP. Expression of p53 protein correlates with decreased survival in patients with areca quid chewing and smoking-associated oral squamous cell carcinoma in Taiwan. *J Oral Pathol Med*. 1999;28:72-76.
  32. Chiba I, Muthumala M, Yamazaki Y, Uz Zaman A, Iizuka T, Amemiya A, Shibata T, Kashiwazaki H, Sugiura C, Fukuda H. Characteristics of mutations in the p53 gene of oral squamous-cell carcinomas associated with betel-quid chewing in Sri Lanka. *Int J Cancer*. 1998;77:839-842.
  33. Choi YL, Park SH, Jang JJ, Park CK. Expression of the G1-S modulators in hepatitis B virus-related hepatocellular carcinoma and dysplastic nodule: Association of cyclin D1 and p53 proteins with the progression of hepatocellular carcinoma. *J Korean Med Sci*. 2001;16:424-432.
  34. Chung FL, Krzeminski J, Wang M, Chen HJ, Prokopczyk B. Formation of the acrolein-derived 1, N2-propanodeoxyguanosine adducts in DNA upon reaction with 3-(N-carboxy-N-nitrosamino) propionaldehyde. *Chem Res Toxicol*. 1994;7:62-67.
  35. Clemente C, Elba S, Buongiorno G, Berloco P, Guerra V, Di Leo A. Serum retinol and risk of hepatocellular carcinoma in patients with Child-Pugh class A cirrhosis. *Cancer Lett*. 2002;178:123-129.
  36. Colombo M. Malignant neoplasms of the liver. In: Schiff ER, Sorrell MF, Maddrey WC, eds. *Schiff's Disease of the Liver*. 9th ed. Philadelphia: Lippincott Williams & Wilkins; 2003:1377-1404.
  37. Darby SC, Ewart DW, Giangrande PLF, Spooner RJD, Rizza CR, Dusheiko GM, Lee CA, Ludlam CA, Preston FE. Mortality from liver cancer and liver disease in haemophilic men and boys in UK given blood products contaminated with hepatitis C. *Lancet*. 1997;350:1425-1431.
  38. Department of Health, Executive Yuan, Republic of China. *Health Statistics: Vital Statistics of the Republic of China*. Taipei, Department of Health, ROC; 2002.
  39. Desai SS, Ghaisas SD, Jakhi SD, Bhide SV. Cytogenetic damage in exfoliated oral mucosal cells and circulating lymphocytes of patients suffering from precancerous oral lesions. *Cancer Lett*. 1996;109:9-14.
  40. Desjardins LA. Hepatocellular carcinoma. *Clin J Oncol Nurs*. 2002;6:107-108.
  41. Deugnier Y, Turlin B. Iron and hepatocellular carcinoma. *J Gastroenterol Hepatol*. 2001;16:491-494.
  42. Dienstag JL, Isselbacher KJ. Tumor of the liver and biliary tract. In: Braunwald E, Fauci AS, Kasper DL, Hauser SL, Longo DL, Janeson JL, eds. *Harrison's Principles of Internal Medicine*. 15th ed. New York: McGraw-Hill; 2001:588-593.
  43. Dominguez-Malagon H, Gaytan-Graham S. Hepatocellular carcinoma: An update. *Ultrastruct Pathol*. 2001;25:497-516.
  44. Donato F, Tagger A, Gelatti U, Parrinello G, Boffetta P, Albertini A, Decarli A, Trevisi P, Ribero ML, Martelli C, Porru S, Nardi G. Alcohol and hepatocellular carcinoma: The effect of lifetime intake and hepatitis virus infections in men and women. *Am J Epidemiol*. 2002;155:323-331.

1026

45. Donato MF, Arosio E, Del Ninno E, Ronchi G, Lampertico P, Morabito A, Balestrieri MR, Colombo M. High rates of hepatocellular carcinoma in cirrhotic patients with high liver cell proliferative activity. *Hepatology*. 2001;34:523-528.
46. Efremidis SC, Hytiroglou P. The multistep process of hepatocarcinogenesis in cirrhosis with imaging correlation. *Eur Radiol*. 2002;12:753-764.
47. El-Serag HB. Epidemiology of hepatocellular carcinoma. *Clin Liver Dis*. 2001;5:87-107.
48. El-Serag HB, Richardson PA, Everhart JE. The role of diabetes in hepatocellular carcinoma: A case-control study among United States Veterans. *Am J Gastroenterol*. 2001;96:2462-2467.
49. Evans AA, Chen G, Ross EA, Shen FM, Lin WY, London WT. Eight-year follow-up of the 90,000-person Haimen City cohort. I. Hepatocellular carcinoma mortality, risk factors, and gender differences. *Cancer Epidemiol Biomarkers Prev*. 2002;11:369-376.
50. Farinati F, Cardin R, Degan P, De Maria N, Floyd RA, Van Thiel DH, Naccarato R. Oxidative DNA damage in circulating leukocytes occurs as early event in chronic HCV infection. *Free Radic Biol Med*. 1999;27:1284-1291.
51. Feitelson M. Chronic hepatitis C virus infection and the pathogenesis of hepatocellular carcinoma. *Arch Immunol Ther Exp*. 2001;49(Suppl 2):S65-74.
52. Feitelson MA, Sun B, Satiroglu Tufan NL, Liu J, Pan J, Lian Z. Genetic mechanisms of hepatocarcinogenesis. *Oncogene*. 2002;21:2593-2604.
53. Filmus J, Robles AI, Shi W, Wong MJ, Columbo LL, Conti CJ. Induction of cyclin D1 overexpression by activated ras. *Oncogene*. 1994;9:3627-3633.
54. Frommel TO, Yong S, Zarling EJ. Immunohistochemical evaluation of Bcl-2 gene family expression in liver of hepatitis C and cirrhotic patients: A novel mechanism to explain the high incidence of hepatocarcinoma in cirrhotics. *Am J Gastroenterol*. 1999;94:178-182.
55. Garner RC. The role of DNA-adducts in chemical carcinogenesis. *Mutation Res*. 1998;402:67-75.
56. Gupta PC. Betel quid and oral cancer: Prospects for prevention. *IARC Sci Publ*. 1991;105:466-470.
57. Hagen TM, Huang S, Curnutte J, Fowler P, Martinez V, Wehr CM, Ames BN, Chisari FV. Extensive oxidative DNA damage in hepatocytes of transgenic mice with chronic active hepatitis destined to develop hepatocellular carcinoma. *Proc Natl Acad Sci U S A*. 1994;91:12808-12812.
58. Hamada H, Yatsubashi H, Yano K, Daikoku M, Arisawa K, Inoue O, Koga M, Nakata K, Eguchi K, Yano M. Impact of aging on the development of hepatocellular carcinoma in patients with posttransfusion chronic hepatitis C. *Cancer*. 2002;95:331-339.
59. Hassan MM, Hwang LY, Hatten CJ, Swaim M, Li D, Abbruzzese JL, Beasley P, Patt YZ. Risk factors for hepatocellular carcinoma: Synergism of alcohol with viral hepatitis and diabetes mellitus. *Hepatology*. 2002;36:1206-1213.
60. Heinzel PA, Balaran P, Bernard HU. Mutations and polymorphisms in the p53, p21 and p16 genes in oral carcinomas of Indian betel quid chewers. *Int J Cancer*. 1996;68:420-423.
61. Ho PS, Ko YC, Yang YH, Shieh TY, Tsai CC. The incidence of oropharyngeal cancer in Taiwan: An endemic betel quid chewing area. *J Oral Pathol Med*. 2002;31:213-219.
62. Holmes-McNary M. Impact factors on development of cirrhosis and subsequent hepatocellular carcinoma. *Compend Contin Educ Dent*. 2001;22:19-33.
63. Hsieh LL, Wang PF, Chen IH, Liao CT, Wang HM, Chen MC, Chang JT, Cheng AJ. Characteristics of mutations in the p53 gene in oral squamous cell carcinoma associated with betel quid chewing and cigarette smoking in Taiwanese. *Carcinogenesis*. 2001;22:1497-1503.
64. Hsu YS, Chien RN, Yeh CT, Sheen IS, Chiou HY, Chu CM, Liaw YF. Long-term outcome after spontaneous HBeAg seroconversion in patients with chronic hepatitis B. *Hepatology*. 2002;35:1522-1527.
65. Huang JS, Ho TJ, Chiang CP, Kok SH, Kuo YS, Kuo MY. MDM2 expression in areca quid chewing-associated oral squamous cell carcinomas in Taiwan. *J Oral Pathol Med*. 2001;30:53-58.
66. Hung HC, Chuang J, Chien YC, Chern HD, Chiang CP, Kuo YS, Hildesheim A, Chen CJ. Genetic polymorphisms of CYP2E1, GSTM1, and GSTT1: Environmental factors and risk of oral cancer. *Cancer Epidemiol Biomarkers Prev*. 1997;6:901-905.
67. Hussain SA, Ferry DR, El-Gazzaz G, Mirza DF, James ND, McMaster P, Kerr DJ. Hepatocellular carcinoma. *Ann Oncol*. 2001;12:161-172.
68. Hwang LS, Wang CK, Sheu MJ, Kao LS. Phenolic compounds of piper betle flower as flavoring and neuronal activity modulating agents. In: Ho CT, Osawa T, Huang MT, Rossen RT, eds. *Food Phytochemicals for Cancer Prevention I*. Washington, DC: American Chemical Society; 1993:186-191.
69. Ishikawa T, Ichida T, Yamagiwa S, Sugahara S, Uehara K, Okoshi S, Asakura H. High viral loads, serum alanine aminotransferase and gender are predictive factors for the development of hepatocellular carcinoma from viral compensated liver cirrhosis. *J Gastroenterol Hepatol*. 2001;16:1274-1281.
70. Jeng JH, Chang MC, Hahn LJ. Role of areca nut in betel quid-associated chemical carcinogenesis: Current awareness and future perspectives. *Oral Oncol*. 2001;37:477-492.
71. Jeng JH, Hahn LJ, Lin BR, Hsieh CC, Chan CP, Chang MC. Effects of areca nut, inflorescence piper betle extracts and arecoline on cytotoxicity, total and unscheduled DNA synthesis in cultured gingival keratinocytes. *J Oral Pathol Med*. 1999;28:64-71.
72. Jussawalla DJ. Oesophageal cancer in India. *J Cancer Res Clin Oncol*. 1981;99:29-33.
73. Kao JH, Chen DS. Recent research progress in hepatocellular carcinoma. *J Formos Med Assoc*. 2002;101:239-248.
74. Kaur J, Srivastava A, Ralhan R. Prognostic significance of p53 protein overexpression in betel- and tobacco-related oral oncogenesis. *Int J Cancer (Pred Oncol)*. 1998;79:370-375.
75. Kiyosawa K, Tanaka E. Characteristics of hepatocellular carcinoma in Japan. *Oncology*. 2002;62(Suppl 1):5-7.
76. Ko YC, Chiang TA, Chang SJ, Hsieh SF. Prevalence of betel quid chewing habit in Taiwan and related sociodemographic factors. *J Oral Pathol Med*. 1992;21:261-264.
77. Ko YC, Huang YL, Lee CH, Chen MJ, Lin LM, Tsai CC. Betel quid chewing, cigarette smoking and alcohol consumption related to oral cancer in Taiwan. *J Oral Pathol Med*. 1995;24:450-453.
78. Koike K, Tsutsumi T, Fujie H, Shintani Y, Kyoji M. Molecular mechanism of viral hepatocarcinogenesis. *Oncology*. 2002;62(Suppl 1):29-37.
79. Kuo MY, Chang HH, Hahn LJ, Wang JT, Chiang CP. Elevated ras p21 expression in oral premalignant lesions and squamous cell carcinoma in Taiwan. *J Oral Pathol Med*. 1995;24:255-260.
80. Kuo MY, Cheng SJ, Chen HM, Kok SH, Hahn LJ, Chiang CP. Expression of CD44s, CD44v5, CD44v6 and CD44v7-8 in betel quid chewing-associated oral premalignant lesions and squamous cell carcinomas in Taiwan. *J Oral Pathol Med*. 1998;27:428-433.
81. Kuo MY, Jeng JH, Chiang CP, Hahn LJ. Mutations of K1-ras oncogene codon 12 in betel quid chewing-related human oral squamous cell carcinoma in Taiwan. *J Oral Pathol Med*. 1994;23:70-74.
82. Kuo MYP, Lin CY, Hahn LJ, Cheng SJ, Chiang CP. Expression of cyclin D1 is correlated with poor prognosis in patients with areca quid chewing-related oral squamous cell carcinomas in Taiwan. *J Oral Pathol Med*. 1999;28:165-169.
83. Kuttan NAA, Rosin MP, Ambika K, Priddy RW, Bhakthan NMG, Zhang L. High prevalence of expression of p53 oncoprotein in oral carcinomas from India associated with betel and tobacco chewing. *Oral Oncol Eur J Cancer*. 1995;31B:169-173.
84. Laurent-Puig P, Legoix P, Bluteau O, Belghiti J, Franco D, Binot F, Monges G, Thomas G, Bioulac-Sage P, Zucman-Rossi J. Genetic alterations associated with hepatocellular carcinomas define distinct pathways of hepatocarcinogenesis. *Gastroenterology*. 2001;120:1763-1773.
85. Lee HC, Yin PH, Yu TN, Chang YD, Hsu WC, Kao SY, Chi CW, Liu TY, Wei YH. Accumulation of mitochondrial DNA deletions in human oral tissues—effects of betel quid chewing and oral cancer. *Mutat Res*. 2001;493:67-74.
86. Liu BH, Hsieh SF, Chang SJ, Ko YC. Prevalence of smoking, drinking

- and betel quid chewing and related factors among aborigines in Wufeng District. *Kaohsiung J Med Sci.* 1994;10:405-411.
87. Liu CJ, Chen CL, Chang KW, Chu CH, Liu TY. Saffrole in betel quid may be a risk factor for hepatocellular carcinoma: Case-report. *CMAJ.* 2000;162:359-360.
  88. Liu TY, Chen CL, Chi CW. Oxidative damage to DNA induced by areca nut extract. *Mutat Res.* 1996;367:25-31.
  89. Lu CT, Lan SJ, Hsieh CC, Yang MJ, Ko YC, Tsai CC, Yen YY. Prevalence and characteristics of areca nut chewers among junior high school students in Changhua county, Taiwan. *Community Dent Oral Epidemiol.* 1993;21:370-373.
  90. Lu CT, Yen YY, Ho CS, Ko YC, Tsai CC, Hsieh CC, Lan SJ. A case-control study of oral cancer in Changhua county, Taiwan. *J Oral Pathol Med.* 1998;25:245-248.
  91. McMahon BJ, Holck P, Bulkow L, Snowball M. Serologic and clinical outcomes of 1536 Alaska natives chronically infected with hepatitis B virus. *Ann Intern Med.* 2001;135:759-768.
  92. Miller EC, Swanson AB, Phillips DH, Fletcher TL, Liem A, Miller JA. Structure-activity studies of the carcinogenicities in the mouse and rat of some naturally occurring and synthetic alkenylbenzene derivatives related to saffrole and estragole. *Cancer Res.* 1983;43:1124-1134.
  93. Ming L, Thorgerisson SS, Gail MH, Lu P, Harris CC, Wang N, Shao Y, Wu Z, Liu G, Wang X, Sun Z. Dominant role of hepatitis B virus and cofactor role of aflatoxin in hepatocarcinogenesis in Qidong, China. *Hepatology.* 2002;36:1214-1220.
  94. Moll UM, Schramm LM. p53: An acrobat in tumorigenesis. *Crit Rev Oral Biol Med.* 1998;9:23-37.
  95. Montalto G, Cervello M, Giannitrapani L, Dantona F, Terranova A, Castagnetta LA. Epidemiology, risk factors, and natural history of hepatocellular carcinoma. *Ann N Y Acad Sci.* 2002;963:13-20.
  96. Moradpour D, Wands JR. Molecular pathogenesis of hepatocellular carcinoma. In: Zakim D, Boyer TD, eds. *Hepatology: A Textbook of Liver Disease.* 4th ed. Philadelphia: Saunders; 2003:1333-1354.
  97. Morcos M, Dubois S, Bralet MP, Belghiti J, Degott C, Terris B. Primary liver carcinoma in genetic hemochromatosis reveals a broad histologic spectrum. *Am J Clin Pathol.* 2001;116:738-743.
  98. Murti PR, Warnakulasuriya KA, Johnson NW, Bhonsle RB, Gupta PC, Daftary DK, Mehta FS. p53 expression in oral precancer as a marker for malignant potential. *J Oral Pathol Med.* 1998;27:191-196.
  99. Nair J, Ohshima H, Nair UJ, Bartsch H. Endogenous formation of nitrosamines and oxidative DNA-damaging agents in tobacco users. *Crit Rev Toxicol.* 1996;26:149-161.
  100. Nair S, Mason A, Eason J, Loss G, Perrillo RP. Is obesity an independent risk factor for hepatocellular carcinoma in cirrhosis? *Hepatology.* 2002;36:150-155.
  101. Nair UJ, Friesen M, Richard I, MacLennan R, Thomas S, Bartsch H. Effect of lime composition on the formation of reactive oxygen species from areca nut extract in vitro. *Carcinogenesis.* 1990;11:2145-2148.
  102. Nair UJ, Floyd RA, Nair J, Bussachini V, Friesen M, Bartsch H. Formation of reactive oxygen species and of 8-hydroxydeoxyguanosine in DNA in vitro with betel quid ingredients. *Chem Biol Interact.* 1987;63:157-169.
  103. Nair UJ, Obe G, Friesen M, Goldberg MT, Bartsch H. Role of lime in the generation of reactive oxygen species from betel-quid ingredients. *Environ Health Perspect.* 1992;98:203-205.
  104. Nair UJ, Nair J, Friesen MD, Bartsch H, Ohshima H. Ortho- and meta-tyrosine formation from phenylalanine in human saliva as a marker of hydroxyl radical generation during betel quid chewing. *Carcinogenesis.* 1995;16:1195-1198.
  105. Nayar D, Kapil U, Joshi YK, Sundaram KR, Srivastava SP, Shukla NK, Tandon RK. Nutritional risk factors in esophageal cancer. *J Assoc Physician India.* 2000;48:781-787.
  106. Nelson BS, Heischouer B. Betel nut: A common drug used by naturalized citizens from India, Far East Asia, and the South Pacific Islands. *Ann Emerg Med.* 1999;34:238-243.
  107. Newberne PM, Butler WH. Acute and chronic effects of aflatoxin on the liver of domestic and laboratory animals: A review. *Cancer Res.* 1969;29:236-250.
  108. Nishida N, Fukuda Y, Komeda T, Kita R, Sando T, Furukawa M, Amenomori M, Shibagaki I, Nakao K, Ikenaga M, et al. Amplification and overexpression of the cyclin D1 gene in aggressive human hepatocellular carcinoma. *Cancer Res.* 1994;54:3107-3110.
  109. Nishikawa A, Prokopczyk B, Rivenson A, Zang E, Hoffmann D. A study of betel quid carcinogenesis. VIII. Carcinogenicity of 3-(methylnitrosamino) propionaldehyde in F344 rats. *Carcinogenesis.* 1992;13:369-372.
  110. Norton SA. Betel: Consumption and consequences. *J Am Acad Derm.* 1998;38:81-88.
  111. Okoshi S, Igarashi M, Suda T, Iwamatsu H, Watanabe K, Ishihara K, Ogata N, Nomoto M, Takahashi T, Ichida T, Asakura H, Nihei K, Kurosaki I. Remote development of hepatocellular carcinoma in patients with liver cirrhosis type B serologically cured for HBs antigenemia with long-standing normalization of ALT values. *Dig Dis Sci.* 2002;47:2002-2006.
  112. Ozturk M. Genetic aspects of hepatocellular carcinogenesis. *Semin Liver Dis.* 1999;19:235-242.
  113. Panigrahi GB, Rao AR. Chromosome-breaking ability of arecoline, a major betel-nut alkaloid, in mouse bone-marrow cells in vivo. *Mutat Res.* 1982;122:347-353.
  114. Peterhans E. Reactive oxygen species and nitric oxide in viral diseases. *Biol Trace Elem Res.* 1997;56:107-116.
  115. Philips DH. DNA adducts derived from saffrole, estragole and related compounds, and from benzene and its metabolites. In: Hemminki K, Dipple A, Shuker DEG, Kadlubar FF, Segerback D, Bartsch H, eds. *DNA Adducts: Identification and Biological Significance.* *IARC Sci Publ.* 1994;125:131-140.
  116. Phukan RK, Ali MS, Chetia CK, Mahanta J. Betel nut and tobacco chewing; potential risk factors of cancer of oesophagus in Assam, India. *Br J Cancer.* 2001;85:661-667.
  117. Popper H, Shafritz DA, Hoofnagle JH. Relation of the hepatitis B virus carrier state to hepatocellular carcinoma. *Hepatology.* 1987;7:764-772.
  118. Prokopczyk B, Bertinato P, Hoffmann D. Cyanoethylation of DNA in vivo by 3-(methylnitrosamino)propionitrile, an areca-derived carcinogen. *Cancer Res.* 1988;48:6780-6784.
  119. Prokopczyk B, Brunemann KD, Bertinato P, Hoffmann D. The role of N-(nitrosomethylamino)propionitrile in betel-quid carcinogenesis. *IARC Sci Publ.* 1987;84:470-473.
  120. Prokopczyk B, Rivenson A, Bertinato P, Brunemann KD, Hoffmann D. 3-(methylnitrosamino) propionitrile: Occurrence in saliva of betel quid chewers, carcinogenicity, and DNA methylation in F344 rats. *Cancer Res.* 1987;47:467-471.
  121. Prokopczyk B, Rivenson A, Hoffmann D. A study of betel quid carcinogenesis. IX. Comparative carcinogenicity of 3-(methylnitrosamino) propionitrile and 4-(methylnitrosamino)-1-(3-pyridyl)-1-butane upon local application to mouse skin and rat oral mucosa. *Cancer Lett.* 1991;60:153-157.
  122. Pugh RN, Murray-Lyon IM, Dawson JL, Peitroni MC, Williams R. Transection of the esophagus for bleeding esophageal varices. *Br J Surg.* 1973;60:646-649.
  123. Raisuddin S, Misra JK. Aflatoxin in betel nut and its control by use of food preservatives. *Food Add Contam.* 1991;8:707-712.
  124. Ramchandani AG, D'Souza AV, Borges AM, Bhisey RA. Evaluation of carcinogenic/co-carcinogenic activity of a common chewing product, pan masala, in mouse skin, stomach and esophagus. *Int J Cancer.* 1998;75:225-232.
  125. Ramkumar D, LaBrecque DR. Drug-induced liver disease and environmental toxins. In: Zakim D, Boyer TD, eds. *Hepatology: A Textbook of Liver Disease.* 4th ed. Philadelphia: Saunders; 2003:755-832.
  126. Rastogi R, Srivastava AK, Srivastava M, Rastogi AK. Hepatocurative effect of picroliv and silymarin against aflatoxin B1 induced hepatotoxicity in rats. *Planta Med.* 2000;66:709-713.
  127. Reichart PA, Phillipsen HP. Betel chewer's mucosa—a review. *J Oral Pathol Med.* 1998;27:239-242.
  128. Rothman KJ. *Modern Epidemiology.* Boston: Little, Brown; 1986:311-326.

1028

129. Saito Y, Ogawa K. Wild type p53 and c-myc co-operation in generating apoptosis of a rat hepatocellular carcinoma cell line (FAA-HTC I). *Oncogene*. 1995;11:1013-1018.
130. Sankaranarayanan R, Duffy SW, Padmakumary G, Nair SM, Day NE, Padmanabhan TK. Risk factors for cancer of the oesophagus in Kerala, India. *Int J Cancer*. 1991;49:485-489.
131. Sarma AB, Chakrabarti J, Chakrabarti A, Banerjee TS, Roy D, Mukherjee D, Mukherjee A. Evaluation of pan masala for toxic effects on liver and other organs. *Food Chem Toxicol*. 1992;30:161-163.
132. Selvan RS, Selvakumar M, Rao AR. Influence of arecoline on immune system. II. Suppression of thymus-dependent immune responses and parameter of non-specific resistance after short-term exposure. *Immunopharmacol Immunotoxicol*. 1991;13:281-309.
133. Shahabuddin S, Rao AR. Effect of arecoline on the humoral and cell mediated immune response in mice. *Indian J Exp Biol*. 1980;18:1493.
134. Shen HM, Ong CN. Mutations of the p53 tumor suppressor gene and ras oncogenes in aflatoxin hepatocarcinogenesis. *Mutat Res*. 1996;366:23-44.
135. Sherlock S, Dooley J. Malignant liver tumors. In: *Disease of the Liver and Biliary System*. 12th ed. Oxford: Blackwell; 2002:537-562.
136. Shimoda R, Nagashima M, Sakamoto M, Yamaguchi N, Hirohashi S, Yokota J, Kasai H. Increased formation of oxidative DNA damage, 8-hydroxydeoxyguanosine, in human livers with chronic hepatitis. *Cancer Res*. 1994;54:3171-3172.
137. Singh A, Rao AR. Effect of arecanut on the black mustard (*Brassica niger*, L.)-modulated detoxication enzymes and sulfhydryl content in the liver of mice. *Cancer Lett*. 1993;72:45-51.
138. Singh A, Rao AR. Modulatory effect of areca nut on the action of mace (*Myristica fragrans*, Houtt) on the hepatic detoxification system in mice. *Food Chem Toxicol*. 1993;31:517-521.
139. Singh A, Rao AR. Effect of arecanut, a masticatory, on hepatic drug metabolizing enzymes—SH content and lipid peroxidation in lactating mothers and their suckling neonates. *Cancer Lett*. 1995;92:175-180.
140. Singh A, Rao AR. Evaluation of the modifying influence of arecanut on the garlic-modulated hepatic detoxication system enzymes, sulfhydryl content, and lipid peroxidation in mice. *Teratog Carcinog Mutagen*. 1995;15:127-134.
141. Smarak S, DeJong UW, Breslow N, Dahl CJ, Ruckphaopunt N, Scheelings P, MacLennan R. Cancer of the oral cavity, pharynx/larynx and lung in northern Thailand. *Br J Cancer*. 1977;36:130-140.
142. Sonzogni L, Sflvestri L, De Sflvestri A, Griffi C, Foti L, Zavagha C, Bottelfi R, Mondelfi MU, Civardi E, Sifinil EM. Polymorphisms of microsomal epoxide hydrolase gene and severity of HCV-related liver disease. *Hepatology*. 2002;36:195-201.
143. Stephen SJ, Uragoda CG. Some observations on oesophageal carcinoma in Ceylon, including its relationship to betel chewing. *Br J Cancer*. 1970;24:11-15.
144. Stich HF, Anders F. The involvement of reactive oxygen species in oral cancers of betel quid/tobacco chewers. *Mutat Res*. 1989;214:47-61.
145. Stich HF, Tsang SS. Promoting activity of betel quid ingredients and their inhibition by retinol. *Cancer Lett*. 1989;45:71-77.
146. Stickel F, Schuppan D, Hahn EG, Seitz HK. Cocarcinogenic effects of alcohol in hepatocarcinogenesis. *Gut*. 2002;51:132-139.
147. Tabor E. The role of tumor suppressor gene in the development of HCC. In: Okuda K, Tabor E, eds. *Liver Cancer*. New York: Churchill Livingstone; 1997:89-95.
148. Talaska G, Au WW, Ward BB, Randerath K, Legator MS. The correlation between DNA adducts and chromosome aberrations in the target organ of benzene exposed, partially-hepatectomized mice. *Carcinogenesis*. 1987;8:1899-1905.
149. Tanaka T, Kuniyasu T, Shima H, Sugie S, Mori H, Takahashi M, Hirono I. Carcinogenicity of betel quid. III. Enhancement of 4-nitroquinoline-1-oxide- and N-2-fluorenylacetylamine-induced carcinogenesis in rats by subsequent administration of betel nut. *J Natl Cancer Inst*. 1986;77:777-781.
150. Tanaka T, Mori H, Fujii M, Takahashi M, Hirono I. Carcinogenicity examination of betel quid. II. Effect of vitamin A deficiency on rats fed semipurified diet containing betel nut and calcium hydroxide. *Nutr Cancer*. 1983;4:260-266.
151. Tazawa J, Maeda M, Nakagawa M, Ohbayashi H, Kusano F, Yamane M, Sakai Y, Suzuki K. Diabetes mellitus may be associated with hepatocarcinogenesis in patients with chronic hepatitis C. *Dig Dis Sci*. 2002;47:710-715.
152. Thomas SJ, MacLennan R. Slaked lime and betel nut cancer in Papua New Guinea. *Lancet*. 1992;340:577-578.
153. Tiemersma EW, Omer RE, Bunschoten A, van't Veer P, Kok FJ, Idris MO, Kadaru AM, Fedail SS, Kampman E. Role of genetic polymorphism of glutathione-S-transferase T1 and microsomal epoxide hydrolase in aflatoxin-associated hepatocellular carcinoma. *Cancer Epidemiol Biomarkers Prev*. 2001;10:785-791.
154. Tsai JF, Chang WY, Jeng JE, Ho MS, Lin ZY, Tsai JH. Hepatitis B and C virus infection as risk factors for liver cirrhosis and cirrhotic hepatocellular carcinoma: A case-control study. *Liver*. 1994;14:98-102.
155. Tsai JF, Chang WY, Jeng JE, Ho MS, Wang LY, Hsieh MY, Chen SC, Chuang WL, Lin ZY, Tsai JH. Hepatitis C virus infection as a risk factor for nonalcoholic liver cirrhosis in Taiwan. *J Med Virol*. 1993;41:296-300.
156. Tsai JF, Chang WY, Jeng JE, Ho MS, Lin ZY, Tsai JH. Frequency of raised alpha-fetoprotein level among Chinese patients with hepatocellular carcinoma related to hepatitis B and C. *Br J Cancer*. 1994;69:1157-1159.
157. Tsai JF, Jeng JE, Chang WY, Lin ZY, Tsai JH. Hepatitis C virus infection among patients with chronic liver disease in an area hyperendemic for hepatitis B. *Stand J Gastroenterol*. 1994;29:550-552.
158. Tsai JF, Jeng JE, Chuang LY, Ho MS, Ko YC, Lin ZY, Hsieh MY, Chen SC, Chuang WL, Wang LY, Yu ML, Dai CY, Ho C. Habitual betel quid chewing as a risk factor for cirrhosis: A case-control study. *Medicine (Baltimore)*. 2003;82:365-372.
159. Tsai JF, Jeng JE, Ho MS, Chang WY, Hsieh MY, Lin ZY, Tsai JH. Additive effect modification of hepatitis B surface antigen and e antigen on the development of hepatocellular carcinoma. *Br J Cancer*. 1996;73:1498-1502.
160. Tsai JF, Jeng JE, Ho MS, Chang WY, Hsieh MY, Lin ZY, Tsai JH. Effect of hepatitis C and B virus infection on risk of hepatocellular carcinoma: A prospective study. *Br J Cancer*. 1997;76:968-974.
161. Tsai JF, Jeng JE, Ho MS, Chang WY, Lin ZY, Tsai JH. Independent and additive effect modification of hepatitis C and B viruses infection on the development of chronic hepatitis. *J Hepatol*. 1996;24:271-276.
162. Tsai JF, Jeng JE, Ho MS, Chang WY, Lin ZY, Tsai JH. Hepatitis B and C virus infection as risk factors for hepatocellular carcinoma in Chinese: A case-control study. *Int J Cancer*. 1994;56:619-621.
163. Vainio H, Wilbourn J. Identification of carcinogenesis within the IARC monograph program. *Stand J Work Environ Health*. 1992;18(Suppl 1):64-73.
164. VanWyk CW. Oral submucous fibrosis. The South African experience. *Indian J Dent Res*. 1997;8:39-45.
165. Wang CK, Peng CH. The mutagenicities of alkaloids and N-nitroquavacoline from betel quid. *Mutat Res*. 1996;360:165-171.
166. Wang CK, Su HY, Lii CK. Chemical composition and toxicity of Taiwanese betel quid extract. *Food Chem Toxicol*. 1999;37:135-144.
167. Wang LY, Hatch M, Chen CJ, Levin B, You SL, Lu SN, Wu MH. Aflatoxin exposure and the risk of hepatocellular carcinoma in Taiwan. *Int J Cancer*. 1996;67:620-625.
168. Williams GM, Laspia MF. The detection of various nitrosamines in the hepatocyte primary culture/DNA repair test. *Cancer Lett*. 1979;6:199-202.
169. Wogan GN. Aflatoxin as a human carcinogen. *Hepatology*. 1999;30:573-575.
170. Wong YK, Liu TY, Chang KW, Lin SC, Chao TW, Li PL, Chang CS. p53 alterations in betel quid- and tobacco-associated oral squamous cell carcinomas from Taiwan. *J Oral Pathol Med*. 1998;27:243-248.
171. Wu MT, Lee YC, Chen CJ, Yang PW, Lee CJ, Wu DC, Hsu HK, Ho CK, Kao EL, Lee JM. Risk of betel chewing for oesophageal cancer in Taiwan. *Br J Cancer*. 2001;85:658-660.
172. Yamoto Y, Yamashita S. Plasma ratio of ubiquinol and ubiquinone as a marker of oxidative stress. *Mol Aspects Med*. 1997;18(Suppl):S79-84.
173. Yamanaka T, Shiraki K, Nakazaawa S, Okano H, Ito T, Deguchi M, Takase K, Nakano T. Impact of hepatitis B and C virus infection on the

- clinical prognosis of alcoholic liver cirrhosis. *Anticancer Res.* 2001;21(4B):2937-2940.
174. Yan JJ, Tzeng CC, Jin TY. Overexpression of p53 protein in squamous cell carcinoma of buccal mucosa and tongue in Taiwan: An immunohistochemical and clinicopathological study. *J Oral Pathol Med.* 1996;25:55-59.
175. Yang HI, Lu SN, Liaw YF, You SL, Sun CA, Wang LY, Hsiao CK, Chen PJ, Chen DS, Chen CJ. Hepatitis B e antigen and the risk of hepatocellular carcinoma. *N Engl J Med.* 2002;347:168-174.
176. Yang MS, Su IH, Wen JK, Ko YC. Prevalence and related risk factors of betel quid chewing by adolescent students in southern Taiwan. *J Oral Pathol Med.* 1996;25:69-71.
177. Zain RB, Ikeda N, Gupta PC, Warnakulasuriya S, van Wyk CW, Shrestha P, Axell T. Oral mucosal lesions associated with betel quid, areca nut and tobacco chewing habits: Consensus from a workshop held in Kuala Lumpur, Malaysia, November 25-27, 1996. *J Oral Pathol Med.* 1999;28:1-4.
178. Zen Y, Katayanagi K, Tsuneyama K, Harada K, Araki I, Nakanuma Y. Hepatocellular carcinoma arising in non-alcoholic steatohepatitis. *Pathol Int.* 2001;51:127-131.
179. Zhang XK, Huang DP, Qiu DK, Chiu JF. The expression of c-myc and c-N-ras in human cirrhotic livers, hepatocellular carcinomas and liver tissue surrounding the tumors. *Oncogene.* 1990;5:909-914.

1030

## Different impact from betel quid, alcohol and cigarette: Risk factors for pharyngeal and laryngeal cancer

Ka-Wo Lee<sup>1,2</sup>, Wen-Rei Kuo<sup>1,2</sup>, Shih-Meng Tsai<sup>3</sup>, Deng-Chyang Wu<sup>4</sup>, Wen-Ming Wang<sup>5</sup>, Fu-Min Fang<sup>6</sup>, Feng-Yu Chiang<sup>1,2</sup>, Kuen-Yao Ho<sup>1,2</sup>, Ling-Feng Wang<sup>1</sup>, Chih-Feng Tai<sup>1,2</sup>, Eing-Long Kao<sup>7</sup>, Shah-Hwa Chou<sup>7</sup>, Chien-Hung Lee<sup>3</sup>, Chee-Yin Chai<sup>8</sup> and Ying-Chin Ko<sup>3,9\*</sup>

<sup>1</sup>Department of Otolaryngology, Kaohsiung Medical University Chung-Ho Memorial Hospital, Kaohsiung Medical University, Taiwan

<sup>2</sup>Department of Otolaryngology, Faculty of Medicine, College of Medicine, Kaohsiung Medical University, Taiwan

<sup>3</sup>Department of Public Health, Faculty of Medicine, College of Medicine, Kaohsiung Medical University, Kaohsiung, Taiwan

<sup>4</sup>Endoscopy Department of Internal Medicine, Kaohsiung Medical University, Kaohsiung, Taiwan

<sup>5</sup>Division of Gastroenterology, Department of Internal Medicine, Kaohsiung Medical University, Kaohsiung, Taiwan

<sup>6</sup>Department of Radiation Oncology, Chang Gung Memorial Hospital, Kaohsiung, Taiwan

<sup>7</sup>Department of Chest Surgery, Kaohsiung Medical University, Kaohsiung, Taiwan

<sup>8</sup>Department of Pathology, Kaohsiung Medical University, Kaohsiung, Taiwan

<sup>9</sup>Division of Environmental Health and Occupational Medicine, National Health Research Institutes, Taiwan

The risks of betel quid chewing with or without tobacco, alcohol drinking and cigarette smoking have been well explored in the oral cavity but not in the pharynx and larynx. We conducted a case-control study to investigate the association of these three risk factors to cancers of the pharynx and larynx in Taiwan. A total cases of 148 pharyngeal cancer, 128 laryngeal cancer and 255 hospital controls, all men, were recruited. Betel quid chewing was a significant independent risk factor (adjusted odds ratio [aOR] = 7.7; 95% confidence interval [CI] = 4.1–15.0) similar to that of alcohol drinking (aOR = 6.6; 95% CI = 3.5–13.0) for pharyngeal cancer, but not for laryngeal cancer (aOR = 1.3; 95% CI = 0.7–2.5) on which cigarette smoking (aOR = 7.1) exerts a stronger significant independent risk than alcohol drinking (aOR = 3.8). For pharyngeal cancers, chewers who consumed >20 quid/day, chewed with inflorescence in the quid or swallowed the betel quid juice were at higher risks; significant dose-response effects were found in daily quantity of drinking and chewing, and cumulative quantity of drinking. Synergistic effects from the 3 risk factors existed both on the pharynx (aOR = 96.9) and the larynx (aOR = 40.3), and attributed for 93.1% and 92.9% respectively. Our study is the first evidence to show that betel quid chewing without tobacco has different impact on the pharynx (digestive tract) and the larynx (airway), and supports the concept that exposure quantity and direct mucosal contact with the betel quid juice may contribute to carcinogenesis. Our results show an important insight into the impact of betel quid chewing on other sites of the digestive tract other than the oral cavity.

© 2005 Wiley-Liss, Inc.

**Key words:** risk factors; areca; laryngeal neoplasms; pharyngeal neoplasms; betel; alcohol; cigarette

Cigarette smoking and alcohol drinking are risk factors for cancers of the oral cavity, pharynx and larynx.<sup>1–6</sup> Betel quid chewing with or without tobacco, a widespread habit in south and east Asian countries, is an important risk factor having both independent and synergistic effects with cigarette smoking and alcohol drinking for oral cancer.<sup>7–13</sup> The risk of betel quid chewing without tobacco on the pharynx and larynx in humans has not been explored and is unknown.

Betel nut (areca nut) is consumed by an estimated 400–600 million people worldwide, mainly IndoAsian, Chinese and Taiwanese. It has a long history of use and is deeply ingrained in many sociocultural and religious activities.<sup>7,14</sup> Betel nut is the seed of the fruit of the oriental palm, *Areca catechu*. It is seldom chewed alone but is usually consumed in the form of betel quid, which is most often prepared by adding different ingredients to the areca nut, for example, the betel fruit (unripe fruit, inflorescence of *Piper betle*), betel leaf (leaf of *Piper betle*), slaked lime, catechu and tobacco, mainly according to the local tradition and for the purpose of flavor enhancing.<sup>7,14</sup> In general, although chewers from different countries prepare betel quid in different ways, the

main components of a betel quid within one geometrical region are quite consistent.

In Taiwan, where 2 million people practice betel quid chewing, a betel quid consists of either a areca nut wrapped with white-lime smeared areca leaf, or a areca nut smeared with red-lime plus a piece of unripe *piper betle* fruit.<sup>8,15</sup> Although tobacco is never chewed together with the quid in contrast with those chewed in other Asian countries like India and Pakistan, the effects of the 3 risk factors: betel quid chewing without tobacco, cigarette smoking and alcohol drinking are still inseparable because the majority of chewers are also cigarette smokers with or without alcohol drinking.<sup>15</sup> Most Taiwanese chewers habitually spit out the excessive betel quid juice and saliva mixture (betel quid juice) while chewing. The quantity of exposure and the duration of mucosal contact of the swallowed betel quid juice in the pharyngo-laryngeal region are far less than those inside the oral cavity. Hence the independent carcinogenic effect and possible synergistic actions, if any, with cigarette and alcohol could differ in the same manner. We carried out a hospital-based case-control study to investigate the carcinogenic impact of betel quid chewing without tobacco, cigarette smoking and alcohol drinking on cancers of the pharynx and larynx.

### Material and methods

#### Study group

From November 2000 to December 2003, 148 pharyngeal cancer patients and 128 laryngeal cancer patients, all male, were recruited from the Otolaryngology Department, Kaohsiung Medical University Hospital (KMUH) and the Department of Radiation Oncology, Kaohsiung Cheng-Gung Memorial Hospital. These teaching hospitals are 2 of the 4 most highly regarded medical centres serving the general population of southern Taiwan, and are freely accessible to patients from all socio-economic groups. All 276 cases were enrolled from a group of 282 eligible patients (refusal rate = 2.1%). All of them had histologically confirmed squamous cell carcinoma at the anatomical sites (ICD-10) of the larynx (C32), hypopharynx (C13) and oropharynx (C10). We excluded cancers of the soft palate (C05.1) and palatine tonsil (C09) in view of their close proximity to the oral cavity and

Grant sponsor: National Health Research Institutes, Taiwan; Grant number: NHRJ-CN-IN-9006P.

\*Correspondence to: Division of Environmental Health and Occupational Medicine, National Health Research Institutes, 100 Shih-Chuan 1st road, Kaohsiung 807, Taiwan, ROC. Fax: +886-7-3346351. E-mail: ycko@nhri.org.tw

Received 16 September 2004; Accepted after revision 18 March 2005  
DOI 10.1002/ijc.21237

Published online 14 June 2005 in Wiley InterScience (www.interscience.wiley.com).



1031

actually being the posterior part of it, on which the 3 risk factors may exert a similar impact as much as that of the oral cavity. These cancers should better be studied together with cancers of the oral cavity elsewhere. Patients with oropharyngeal and hypopharyngeal cancers were then grouped under pharyngeal cancer patients. The control group consisted of 255 non-frequency-matched males 40 years of age or older. They were enrolled from a group of 289 eligible subjects (refusal rate = 11.8%) who visited the Otolaryngology Outpatient or Inpatient Department of KMH during the study period. None of the controls had malignant tumours or any condition known to be associated with betel chewing, cigarette smoking and alcohol consumption. The diagnosis (number of subjects) of the controls were allergic rhinitis (21), chronic paranasal sinusitis (10), acute rhinitis (26), common cold (35), chronic tonsillitis (8), foreign body of pharynx (9), branchial cleft cyst (4), thyroglossal duct cyst (3), peritonsillar abscess (12), deep neck infection (4), Ménière's disease (15), sensorineural hearing loss (29), sudden hearing loss (12), tinnitus (30), acute otitis externa (10), otomycosis (8) and chronic otitis media (19). Our study has been approved by the Institutional Research Board of KMH. Informed written consents were obtained from all cases and controls.

#### Personal interview

A trained interviewer met all cases and controls using a standard structured questionnaire, collecting information on socio-demographic characteristics, occupation and historical information such as whether or not the patients were users: betel-quid chewers (one quid or more daily for at least 1 year), cigarette smokers (one cigarette or more per day for at least 1 year) and alcohol drinkers (drinking more than 4 days a week for at least 1 year). Current users were those who had the habits at interviews or those who had refrained from the habits <1 year. Ex-users were those who had abstained from the habits for >1 year before interviews. Non-users were defined as whether the patients were non-chewers, non-smokers or non-drinkers who had never had betel-quid, cigarette or alcoholic beverage lifelong. The duration of habits, age at starting habits, types of alcohol beverages, average daily quantity of

consumption were also recorded. To assess the cumulative risks of cigarette smoking and alcohol drinking, the "quantity-years" was calculated (daily quantity  $\times$  years of use). A field supervisor checked all completed questionnaires and the relevant medical records. Data were then transferred to coding sheets for further computer analysis.

#### Statistical analyses

Adjusted odds ratios (aOR) and the respective 95% confidence intervals (CI) were estimated by maximum likelihood estimation for each possible risk factor in pharyngeal cancer and laryngeal cancer patients using unconditional logistic regression model.<sup>16</sup> To control for potential confounding effects, aOR were adjusted for age, years of education whenever appropriate and other covariates. Likelihood ratio tests were carried out for trend with amount or duration of important covariate by subtraction of G statistics of the 2 different models and then estimating with  $\chi^2$  distribution according to appropriate degree of freedom. Interactive effects of each risk factor were evaluated by assuming an additive interaction relation as described by Rothman and Greenland.<sup>17</sup> Using Bruzzi's method, the corresponding population attributable risk proportion (PAR%) of pharyngeal and laryngeal cancers attributable to the three risk factors were calculated.<sup>18</sup> All PAR% were also adjusted for age and other covariates.

#### Results

The median age among 148 pharyngeal cancer patients was 53 (range = 41–80), whereas that of 128 laryngeal cancer patients was 61 (range = 43–89), and that of 255 controls was 53 (range = 40–92). Although our controls were non-frequency matched, but their age ranges were comparable with those of the cases. There was no significant association between years of education and both pharyngeal/laryngeal cancer risk (data not shown).

Compared to non-smokers, higher risks were found among both ex-smokers (aOR = 4.3) and current smokers (aOR = 8.3) for laryngeal cancer (Table I). Significant associations and trends (*p* for

TABLE I - ESTIMATED aOR FOR DIFFERENT CIGARETTE SMOKING CHARACTERISTICS

Cigarette smoking/category	Control n <sup>1</sup>	Pharyngeal cancer		Laryngeal cancer	
		n <sup>1</sup>	aOR <sup>2</sup> (95% CI)	n <sup>1</sup>	aOR <sup>2</sup> (95% CI)
Smoking status					
Non-smokers	128	18	1.0	13	1.0
Smokers	127	130	1.8 (0.8–4.0)	115	7.1 (3.5–16.0)
Ex-smokers	27	25	1.6 (0.6–4.6)	22	4.3 (1.9–12.6)
Current smokers	100	105	1.8 (0.8–4.2)	93	8.3 (3.9–18.6)
Starting age					
Non-smokers	128	18	1.0	13	1.0
>=20 year-old	41	37	1.9 (0.7–5.3)	17	7.0 (2.5–20.6)
<20 year-old	84	91	1.7 (0.8–3.9)	96	7.3 (3.5–16.5)
Duration (years)					
Non-smokers	128	18	1.0	13	1.0
<=25	41	37	1.8 (0.8–4.0)	17	6.9 (3.3–15.7)
>25	84	91	1.6 (0.4–5.8)	96	8.7 (3.0–26.2)
<i>p</i> for trend			0.27		<0.0001
Daily quantity (cigarette/day)					
Non-smokers	128	18	1.0	13	1.0
<=20	105	90	1.7 (0.8–3.8)	82	6.5 (3.1–14.8)
>20	22	40	2.2 (1.0–5.9)	31	11.3 (4.3–31.3)
<i>p</i> for trend			0.14		<0.0001
Cumulative exposure <sup>3</sup> (cigarette-years)					
Non-smokers	128	18	1.0	13	1.0
<500	52	30	1.2 (0.5–3.1)	25	5.2 (2.2–13.2)
500-1000	47	65	2.1 (0.9–5.0)	51	9.0 (4.0–22.0)
>1000	21	26	2.3 (0.8–6.6)	36	10.0 (3.9–26.8)
<i>p</i> for trend			0.06		<0.0001

<sup>1</sup>Total sample size varies with the number of cases having available data. <sup>2</sup>OR were adjusted for alcohol drinking, betel chewing and age. Education level was not adjusted because it was not significantly associated with pharyngeal and laryngeal cancers. <sup>3</sup>Calculated by daily quantity  $\times$  years of use; for example, smoking 30 cigarettes daily for 20 years, the cumulative exposure = 30  $\times$  20 = 600 cigarette-years.

1032

TABLE II - ESTIMATED aOR FOR DIFFERENT ALCOHOL DRINKING CHARACTERISTICS

Alcohol drinking/category	Control n <sup>1</sup>	Pharyngeal cancer		Laryngeal cancer	
		n <sup>1</sup>	aOR <sup>2</sup> (95% CI)	n <sup>1</sup>	aOR <sup>2</sup> (95% CI)
Drinking status					
Non-drinkers	204	28	1.0	56	1.0
Drinkers	51	120	6.6 (3.5-13.0)	72	3.8 (2.1-7.0)
Ex-drinkers	11	22	7.4 (2.8-20.3)	12	3.0 (0.2-3.4)
Current drinkers	40	98	6.4 (3.3-13.9)	60	4.1 (2.5-8.8)
Starting age					
Non-drinkers	204	28	1.0	56	1.0
>=20 year-old	36	91	7.4 (3.7-14.9)	54	3.9 (2.1-7.4)
<20 year-old	14	28	7.1 (2.9-18.4)	16	3.4 (1.4-8.8)
Duration (years)					
Non-drinkers	204	28	1.0	56	1.0
<=30	35	75	7.0 (3.4-14.9)	29	3.2 (1.5-7.0)
>30	16	40	5.0 (2.0-12.4)	39	4.1 (2.0-8.7)
<i>p</i> for trend			<0.0001		<0.0001
Daily quantity (ml/day) <sup>3</sup>					
Non-drinkers	204	28	1.0	56	1.0
<=750	46	84	5.3 (2.7-10.9)	52	3.1 (1.7-5.8)
>750	4	31	32.5 (10.0-130.9)	15	10.3 (3.0-42.5)
<i>p</i> for trend			<0.0001		<0.0001
Cumulative exposure <sup>4</sup> (ml/years)					
Non-drinkers	204	28	1.0	56	1.0
<7500	24	11	1.0 (0.3-2.9)	11	1.3 (0.5-3.4)
7500-15000	11	24	4.5 (1.6-13.2)	11	2.3 (0.8-7.0)
>15000	8	38	20.7 (7.4-64.5)	28	8.6 (3.5-23.2)
<i>p</i> for trend			<0.0001		<0.0001

<sup>1</sup>Total sample size varies with the number of cases having available data. <sup>2</sup>OR were adjusted for cigarette smoking, betel chewing and age. Education level was not adjusted because it was not significantly associated with pharyngeal and laryngeal cancers. <sup>3</sup>Quantity expressed in an equivalent of ml of beer (5% ethanol) consumed daily; wine (10-12% ethanol) and spirits (35-45% ethanol) were accordingly converted to their equivalent quantity (ml) of beer in proportion to their own ethanol concentration. <sup>4</sup>Calculated by daily quantity  $\times$  years of use; for example, drinking 700 ml of beer daily for 20 years, the cumulative exposure = 700  $\times$  20 = 14,000 ml/years.

trend < 0.0001) were observed between smoking duration/daily quantity/cumulative exposure and laryngeal cancer risk but not pharyngeal cancer risk. The risk for pharyngeal cancer among both ex-smokers and current smokers had weaker significance in our study. Current drinkers were at higher risks at both sites (Table II). At each different level of drinking duration, daily consumption and cumulative exposure, alcohol drinkers had shown higher aORs for pharyngeal cancer than for laryngeal cancer. The *p* for trend values of these drinking characteristics were all statistically significant at both sites.

The impact of betel quid chewing are shown in Table III. For laryngeal cancer, no significant increased risk could be detected among ex-chewers and current chewers, or at each level and type of exposure combination. Among pharyngeal cancer patients, however, significant increased risks were found among both ex- and current chewers. Chewers had an overall aOR of 7.7 (95% CI = 4.1-15.0). Different types of quid had variable risks. Chewers using betel inflorescence in the quid had a highest risk (aOR = 13.5) whereas those using betel leaf had the lowest (aOR = 5.4). Chewers who consumed a higher daily quantity of betel quid (>20 pieces a day; aOR = 7.2) showed a higher risk than those who consumed less each day; a significant dose-effect response was evident (*p* for trend < 0.0001). Chewers who swallowed the betel quid juice had a higher risk (aOR = 8.7) than non-swallowers (aOR = 6.2) for pharyngeal cancer.

Table IV shows the synergistic effects of different habits combinations. Of the total 148 pharyngeal cancer patients, 120 (81.0%) were alcohol drinkers, 115 (77.7%) betel chewers and 130 (87.8%) were betel chewers. Only 3 (2.0%) were betel chewers alone (B), 3 (2.0%) alcohol drinkers alone (A) and 4 (2.7%) cigarette smokers alone (C). There was only one betel chewer alone among all 255 controls. The small number of cases and controls in this subgroup of betel chewers alone resulted in an unavoidable unstable estimation of risk. Of all pharyngeal cancer, a highest risk

(aOR = 96.9) was observed among 97 patients who were concomitant alcohol, betel and cigarette users (A + B + C) as compared to that of both betel and cigarette (B + C) users (aOR = 19.0), that of both alcohol and cigarette (A + C) users (aOR = 18.1), and that of both alcohol and betel (A + B) users (aOR = 18.4). For laryngeal cancer patients, 115 (89.8%) of the total 128 were smokers. The aORs were 7.4 for cigarette alone, 7.3 for alcohol alone, 27.9 for A + C users and 11.5 for B + C users. Because there was no chewer who did not smoke (all chewers were also smokers with or without drinking habit) in laryngeal cancer group, the risk for both betel alone and A + B subgroups could not be elucidated. For patients who were concomitant A + B + C users, a highest risk (aOR = 40.3) for laryngeal cancer was observed.

The attributable fraction of cigarette smoking (PAR% = 77) was higher than that of alcohol drinking (PAR% = 40) to the larynx. For pharyngeal cancer, the attributable risk from betel quid chewing (PAR% = 67) was relatively close to that from alcohol drinking (PAR% = 73), and both were higher than that of cigarette smoking (PAR% = 43). The summary attributable fraction from the 3 risk factors to the pharynx and the larynx were 93.1% and 92.9% respectively.

## Discussion

Betel chewing is an important risk factor for pre-cancer and cancerous conditions of the oral cavity in betel chewers.<sup>8,10-12,19</sup> The chemical compounds of a betel quid are complex. According to the evaluation of carcinogenic risks to humans by the International Agency for Research on Cancer (IARC) in 1985, only betel quid chewing with tobacco was evaluated as "carcinogenic to human" (Group I). A new re-evaluation by IARC in 2004 concluded, for the first time, that both betel quid without tobacco (sufficient evidence of an increased risk of oral cancer and experimental animals) and areca nut (sufficient evidence of carcinogenicity

TABLE III - ESTIMATED aOR FOR DIFFERENT BETEL QUID CHEWING CHARACTERISTICS

Betel quid chewing/category	Control n <sup>1</sup>	Pharyngeal cancer		Laryngeal cancer	
		n <sup>1</sup>	aOR <sup>2</sup> (95% CI)	n <sup>1</sup>	aOR <sup>2</sup> (95% CI)
<b>Chewing status</b>					
Non-chewers	216	33	1.0	85	1.0
Chewers	39	115	7.7 (4.1-15.0)	43	1.3 (0.7-2.5)
Ex-chewers	11	44	9.5 (4.3-28.1)	15	1.5 (0.6-3.9)
Current chewers	28	71	6.9 (3.4-14.3)	28	1.3 (0.6-2.7)
<b>Starting age</b>					
Non-chewers	214	33	1.0	85	1.0
>=20 year-old	13	55	9.9 (4.4-23.8)	21	2.0 (0.8-4.8)
<20 year-old	26	57	4.6 (2.2-9.9)	22	1.0 (0.5-2.2)
<b>Daily quantity (pieces/day)</b>					
Non-chewers	216	33	1.0	85	1.0
<=20	12	16	2.5 (1.0-3.8)	15	1.3 (0.5-3.3)
>20	27	92	7.2 (3.6-14.8)	25	1.2 (0.6-2.5)
<i>p</i> for trend			<0.0001		0.62
<b>Type of quid</b>					
Non-chewers	216	33	1.0	85	1.0
With betel inflorescence	4	30	13.5 (4.3-52.5)	12	2.9 (0.8-11.5)
With betel leaf	24	57	5.4 (2.5-11.7)	20	0.8 (0.4-1.9)
Mixed	10	21	5.8 (2.3-15.7)	10	1.9 (0.7-5.3)
<b>Betel-quin juice swallowing</b>					
Non-chewers	216	33	1.0	85	1.0
Never swallowed	25	61	6.2 (3.0-13.0)	28	1.7 (0.8-3.5)
Swallowed	7	34	8.7 (3.2-26.0)	13	1.9 (0.6-6.0)
Not sure	7	13	5.0 (1.6-16.8)	2	0.2 (0.03-1.0)

<sup>1</sup>Total sample size varies with the number of cases having available data. <sup>2</sup>OR were adjusted for cigarette smoking, alcohol drinking and age. Education level was not adjusted because it was not significantly associated with pharyngeal and laryngeal cancers.

TABLE IV - INTERACTIONS AMONG ALCOHOL, BETEL QUID, AND CIGARETTE FOR PHARYNGEAL AND LARYNGEAL CANCERS

Alcohol (A)	Betel quid (B)	Cigarette (C)	Control n	Cancer sites			
				Pharynx		Larynx	
				N	aOR <sup>1</sup> (95% CI)	N	aOR <sup>1</sup> (95% CI)
-	-	-	117	9	1.0	10	1.0
+	-	-	7	3	8.6 (1.5-45.7)	3	7.3 (1.3-36.0)
-	+	-	1	3	40.9 (4.2-938.1)	0	-
-	-	+	72	4	1.1 (0.3-4.2)	35	7.4 (3.1-19.7)
+	+	-	3	3	18.4 (2.8-125.4)	0	-
+	-	+	20	17	18.1 (6.0-61.9)	37	27.9 (10.9-80.9)
-	+	+	14	12	19.0 (5.7-70.6)	11	11.5 (3.6-39.5)
+	+	+	21	97	96.9 (36.5-308.0)	32	40.3 (14.8-123.6)

<sup>1</sup>Adjusted OR were estimated by 7 dummy variables according to the exposure of alcohol, betel quid, and cigarette and adjusted for age. Education level was not adjusted because it was not significantly associated with pharyngeal and laryngeal cancers.

in experimental animals) are carcinogenic to humans (Group 1).<sup>20</sup> Only men were included in our study because the majority of patients with pharyngeal or laryngeal cancers are men in Taiwan. To avoid bias in patient selection that may lead to in homogeneity in the extent of risk factor exposure, we have confined our pharyngeal cancer patients with strict definition.

#### Betel quid chewing vs. pharynx and larynx

Our study showed that betel quid chewing without tobacco had a significant independent risk for pharyngeal cancer but not for laryngeal cancer. The aOR for laryngeal cancer across the various chewing characteristics were not statistically significant. For the pharynx, both ex-chewers and current chewers had significant increased risks (Table III). These new findings are in contrast with the recent report by Znaor *et al.*<sup>21</sup> who showed a non-significant result of betel quid without tobacco (OR = 1.37; 95% CI = 0.89-2.10) in pharyngeal cancer patients (no data available for the larynx). Interestingly, betel quid with betel inflorescence had a stronger risk as compared to that with betel leaf. This can be at least partly explained by a proposed antimutagenic effect of the leaf.<sup>22,23</sup> More importantly, a significant increased risk and a posi-

tive trend were found in relation to daily quantity of betel use, suggesting the importance of the quantity of carcinogen exposure. In a study in Papua New Guinea by Thomas and MacLennan,<sup>24</sup> oral cancers were mostly found at the corner of the mouth and cheek that corresponds precisely with the application of the lime while chewing, causing the mean pH to rise to 10. Interestingly, our data showed that pharyngeal cancer patients who were betel quid juice swallows (aOR = 8.7) had a higher risk than non-swallows (aOR = 6.2), a possible similar adverse effect from the direct contact of betel quid juice with the pharyngeal mucosa could be present. The above results indicate that betel quid chewing without tobacco had significant independent risk to the pharynx (digestive tract) rather than the larynx (upper air way).

#### Cigarette smoking vs. pharynx and larynx

Some epidemiological studies have reported higher risks of smoking for the larynx than the pharynx while others had the opposite results. Choi *et al.*<sup>6</sup> concluded that the risk for cancer of the oral cavity, pharynx and larynx rose for current smokers but declined for ex-smokers. Duration of smoking and daily quantity were significantly associated with higher risks. An IARC interna-

1134

tional case-control study with 1,147 male cases and 3,057 controls by Tuyns *et al.*<sup>25</sup> showed that the effect of tobacco is similar at all sites of the larynx/hypopharynx, with elevated risk on the order of 10 at all sites for ever smokers. Menvielle *et al.*<sup>26</sup> also reported that subsites of the larynx and hypopharynx did not differ significantly in risk in relation to tobacco smoking and the OR among current smokers ranged from 3-44. Franceschi *et al.*<sup>1</sup> showed that OR from smoking for pharynx and larynx were 12.9 and 4.6, respectively. Heterogeneity in estimates of risk among these studies could be due to different definitions or selections on exposure quantity, duration, anatomical sites and other confounding.

We have found that risk of cigarette smoking to the larynx was significantly higher than that to the pharynx across each category subgroups. Higher daily quantity and cumulative exposure, longer smoking duration and current smokers had higher risks for laryngeal cancer. More importantly, significant positive trends of risk across all category subgroups were shown on the larynx but not on the pharynx (Table I). These results were in concordance with those reported by others.<sup>27-29</sup> Although pharyngeal cancer risk seemed only to be modestly increased with less statistical significance in current smokers (aOR = 1.8; 95%CI = 0.8-4.2), significant increased risk was found in higher daily quantity smokers (>20/day; aOR = 2.2; 95%CI = 1.0-5.9). Overall, our results indicate that cigarette smoking was a stronger independent risk factor to the larynx than the pharynx.

#### *Alcohol drinking vs. pharynx and larynx*

Epidemiological studies clearly indicate that drinking alcoholic beverages are causally related to cancers of the oral cavity, pharynx (excluding the nasopharynx) and the larynx. Generally, there has been no indication that the effect is dependent on type of beverage. In 14 case-control studies in North America and Europe all showed that the relative risk increased with level of intake of alcoholic beverages.<sup>30</sup> A recent report by Menvielle *et al.*<sup>26</sup> showed that alcohol consumption had a significantly higher increased risk for hypopharyngeal cancer than for glottic and supraglottic cancers. From various consumption levels, OR ranged from 1.4-5.9 among regular drinkers. Tuyns *et al.*<sup>25</sup> reported, based on a multinational case-control study on 1,147 male cases and 3,057 male population controls, that the risks from alcohol drinking depend on site: for drinking level of >80 g/day, the epilarynx and hypopharynx (RR = 4.3) had a higher risk than the endolarynx (RR = 2.1). Many others have reported the odds ratios relating to alcohol drinking for the pharynx and larynx.<sup>1,5,6</sup> In this investigation, aOR of current drinkers for pharyngeal cancer (aOR = 6.4) was higher than that for laryngeal cancer (aOR = 4.1). Alcohol drinking had higher odds ratios across the categories of drinking duration, daily quantity and cumulative exposure level in pharyngeal cancer than in laryngeal cancer (Table II), indicating that alcohol drinking has a more prominent independent carcinogenic effect and stronger dose-response effect on the pharynx than on the larynx.

#### *Interactions among the risk factors*

For pharyngeal cancer, Blot *et al.*<sup>31</sup> reported among consumers of both alcohol and cigarette, risks of oropharyngeal cancer tended to combine more in a multiplicative than additive fashion and were increased more than 35-fold among those who consumed 2 or more packs of cigarettes and >4 alcoholic drinks per day. For laryngeal cancer, Dosemeci *et al.*<sup>28</sup> in Turkey reported that the relative risk of joint exposure to smoking and alcohol was 12.2. Talamini *et al.*<sup>27</sup> reported in a study conducted in northern Italy and Switzerland, that combined alcohol and tobacco consumption showed a higher, multiplicative (OR = 177) rather than an additive risk. The discrepancy in estimation of risks among these studies could be due to the fact that smoking patterns differ largely and drinking patterns relating to overall level of alcohol consumption, choice of alcoholic beverages, differences by gender and age and temporal variations, differ among and within societies worldwide.

Adding the effect of betel quid chewing to drinking and smoking becomes more complicated in elucidating their combine risks. In our previous study for oral cancer in Taiwan, the occurrence of oral cancer was 123-fold higher in patients who were concomitant A + B + C users than in abstainers.<sup>8</sup> Our present results show that for the pharynx, concomitant A + B + C users had a highest risk in compare with those users having any one or two of the three habits, showing the presence of synergistic effects (Table IV). For betel chewing, the small numbers of patient in betel chewing alone subgroup reflects the real chewing pattern in Taiwan: the majority of chewers are also cigarette smokers (96.2% of cases and 89.7% of controls) with or without alcohol drinking. Nevertheless, the estimated aOR of concomitant A + B + C users for the pharynx (aOR = 96.9) was higher than that for the larynx (aOR = 40.3), but both were lower than that of the oral cavity reported in our previous study. Our present data indicate that the quantity of exposure and direct mucosal contact by the carcinogens of the betel quid to the mucosa of the pharynx and larynx, besides other site-specific factors, may be different and hence may lead to different impact on these 2 target organs in the course of carcinogenesis.

Our study has a number of strengths. Most notably, this is the first report demonstrating a positive independent carcinogenic role of betel quid without tobacco on the pharynx but not the larynx in a community where all chewers never add tobacco to the quid. This will provide a chance to investigate the impact from the betel quid without the interference from the chewed tobacco. Second, the pharyngeal cancer group were homogeneous, so as to achieve a more accurate estimation of risks in the pharynx. Finally, we have reached a new finding that in concomitant alcohol, betel and cigarette users, the combined risks from the 3 risk factors on the pharynx and the larynx are lower than that in the oral cavity. This investigation also has some limitations inherent in any hospital-based case-control investigations. Among the controls, selection bias is always a concern. Although we have excluded those having any condition known to be associated with the 3 risk factors, individuals from the outpatient and inpatient department of a hospital might have more unhealthy habits than the general population. Hence ending up with potential underestimated results in the cases relative to those that might have been seen with truly comparable controls. Estimates of the quantity of alcohol drinking, betel chewing and cigarette smoking are difficult and tend to be imprecise. More specifically, the small or null number of subjects in a few but critical subgroups in our controls and cases resulted in limited statistical power or unavailability of data in part of our analysis. This shortcoming heralds the need for a long-term collection of more cases and controls who are betel quid chewers alone.

#### **Conclusion**

In conclusion, betel quid chewing is an important attributable factor and a strong independent risk factor for pharyngeal cancer similar to that of alcohol drinking, but not for laryngeal cancer on which cigarette smoking exerts a stronger carcinogenic effect than alcohol drinking. However, synergistic effects from these three risk factors exist both on the pharynx and the larynx. Our results implicate that the exposure quantity and direct mucosal contact with the carcinogen with the target organ may contribute to the process of carcinogenesis. Further studies to explore the associations between betel quid chewing and cancers of other sites of the digestive tract, for example, the esophagus and stomach, and the effects on other systems of humans are necessary.

#### **Acknowledgements**

The authors thank Ms. Y.-J. Wang and Ms. S.-L. Chou for their clerical assistance.

1035  
f

## References

1. Franceschi S, Talamini R, Barra S, Baron AE, Negri E, Bidoli E, Serraino D, La Vecchia C. Smoking and drinking in relation to cancers of the oral cavity, pharynx, larynx, and esophagus in northern Italy. *Cancer Res* 1990;50:6502-7.
2. Franceschi S, Levi F, La Vecchia C, Conti E, Dal Maso L, Barzan L, Talamini R. Comparison of the effect of smoking and alcohol drinking between oral and pharyngeal cancer. *Int J Cancer* 1999;83:1-4.
3. Mashberg A, Boffetta P, Winkelman R, Garfinkel L. Tobacco smoking, alcohol drinking, and cancer of the oral cavity and oropharynx among U.S. Veterans. *Cancer* 1993;72:1369-75.
4. Menvielle G, Luce D, Goldberg P, Leclerc A. Smoking, alcohol drinking, occupational exposures and social inequalities in hypopharyngeal and laryngeal cancer. *Int J Epidemiol* 2004;33:799-806.
5. Bosetti C, Gallus S, Franceschi S, Levi F, Bertuzzi M, Negri E, Talamini R, La Vecchia C. Cancer of the larynx in non-smoking alcohol drinkers and in non-drinking tobacco smokers. *Br J Cancer* 2002;87:516-8.
6. Choi SY, Kahyo H. Effect of cigarette smoking and alcohol consumption in the aetiology of cancer of the oral cavity, pharynx and larynx. *Int J Epidemiol* 1991;20:878-85.
7. Warnakulasuriya S, Trivedy C, Peters TJ. Areca nut use: an independent risk factor for oral cancer. *BMJ* 2002;324:799-800.
8. Ko YC, Huang YL, Lee CH, Chen MJ, Lin LM, Tsai CC. Betel quid chewing, cigarette smoking and alcohol consumption related to oral cancer in Taiwan. *J Oral Pathol Med* 1995;24:450-3.
9. Shiu MN, Chen TH. Impact of betel quid, tobacco and alcohol on three-stage disease natural history of oral leukoplakia and cancer: implication for prevention of oral cancer. *Eur J Cancer Prev* 2004;13:39-45.
10. Lee CH, Ko YC, Huang HL, Chao YY, Tsai CC, Shieh TY, Lin LM. The precancer risk of betel quid chewing, tobacco use and alcohol consumption in oral leukoplakia and oral submucous fibrosis in southern Taiwan. *Br J Cancer* 2003;88:366-72.
11. Zain RB, Ikeda N, Gupta PC, Warnakulasuriya S, van Wyk CW, Shrestha P, Axell T. Oral mucosal lesions associated with betel quid, areca nut and tobacco chewing habits: consensus from a workshop held in Kuala Lumpur, Malaysia, November 25-27, 1996. *J Oral Pathol Med* 1999;28:1-4.
12. Reichart PA. Oral cancer and precancer related to betel and miang chewing in Thailand: A review. *J Oral Pathol Med* 1995;24:241-3.
13. Thomas S, Kearsley J. Betel quid and oral cancer: a review. *Eur J Cancer B Oral Oncol* 1993;29B:251-5.
14. Gupta PC, Warnakulasuriya S. Global epidemiology of areca nut usage. *Addict Biol* 2002;7:77-83.
15. Ko YC, Chiang TA, Chang SJ, Hsieh SF. Prevalence of betel quid chewing habit in Taiwan and related sociodemographic factors. *J Oral Pathol Med* 1992;21:261-4.
16. Breslow NE, Day NE. Statistical methods in cancer research, vol. II. The analysis of case-control studies. IARC Scientific Publications no 32. Lyon: IARC, 1980.
17. Rothman KJ, Greenland S. Modern epidemiology, 2nd ed. Philadelphia: Williams & Wilkins, 1998. 329 p.
18. Bruzzi P, Green SB, Byar DP, Brinton LA, Schairer C. Estimating the population attributable risk for multiple risk factors using case-control data. *Am J Epidemiol* 1985;122:904-14.
19. Jacob BJ, Straif K, Thomas G, Ramadas K, Mathew B, Zhang ZF, Sankaranarayanan R, Hashibe M. Betel quid without tobacco as a risk factor for oral precancers. *Oral Oncol* 2004;40:697-704.
20. IARC. Monographs on the evaluation of carcinogenic risks of chemical to humans. Betel-quid and areca-nut chewing and some areca-nut related nitrosamines. vol. 85. Lyon: IARC, 2004.
21. Znaor A, Brennan P, Gajalakshmi V, Mathew A, Shanta V, Varghese C, Boffetta P. Independent and combined effects of tobacco smoking, chewing and alcohol drinking on the risk of oral, pharyngeal and esophageal cancers in Indian men. *Int J Cancer* 2003;105:681-6.
22. Shimame LP, Menon MM, Nair J, Bhide SV. Correlation of mutagenicity and tumorigenicity of betel quid and its ingredients. *Nutr Cancer* 1983;5:87-91.
23. Amonkar AJ, Nagabhushan M, D'Souza AV, Bhide SV. Hydroxychavicol: a new phenolic antimutagen from betel leaf. *Food Chem Toxicol* 1986;24:1321-4.
24. Thomas SJ, MacLennan R. Slaked lime and betel nut cancer in Papua New Guinea. *Lancet* 1992;340:577-8.
25. Tuyns AJ, Esteve J, Raymond L, Berrino F, Benhamou E, Blanchet F, Boffetta P, Crosignani P, del Moral A, Lehmann W, Merletti F, Pequinot G, et al. Cancer of the larynx/hypopharynx, tobacco and alcohol: IARC international case-control study in Turin and Varese (Italy), Zaragoza and Navarra (Spain), Geneva (Switzerland) and Calvados (France). *Int J Cancer* 1988;41:483-91.
26. Menvielle G, Luce D, Goldberg P, Bugel I, Leclerc A. Smoking, alcohol drinking and cancer risk for various sites of the larynx and hypopharynx. A case-control study in France. *Eur J Cancer Prev* 2004;13:165-72.
27. Talamini R, Bosetti C, La Vecchia C, Dal Maso L, Levi F, Bidoli E, Negri E, Pasche C, Vaccarella S, Barzan L, Franceschi S. Combined effect of tobacco and alcohol on laryngeal cancer risk: a case-control study. *Cancer Causes Control* 2002;13:957-64.
28. Dosemeci M, Gokmen I, Unsal M, Hayes RB, Blair A. Tobacco, alcohol use, and risks of laryngeal and lung cancer by subsite and histologic type in Turkey. *Cancer Causes Control* 1997;8:729-37.
29. Tavani A, Negri E, Franceschi S, Barbone F, La Vecchia C. Attributable risk for laryngeal cancer in northern Italy. *Cancer Epidemiol Biomarkers Prev* 1994;3:121-5.
30. IARC. Monographs on the evaluation of carcinogenic risks of chemical to humans. Alcohol drinking. vol. 44. Lyon: IARC, 1988.
31. Blot WJ, McLaughlin JK, Winn DM, Austin DF, Greenberg RS, Preston-Martin S, Bernstein L, Schoenberg JB, Stemhagen A, Fraumeni JF Jr. Smoking and drinking in relation to oral and pharyngeal cancer. *Cancer Res* 1988;48:3282-7.

## Original Contribution

### Areca Nut Chewing and Mortality in an Elderly Cohort Study

Tzuo-Yun Lan<sup>1</sup>, Wen-Chiung Chang<sup>1</sup>, Yih-Jian Tsai<sup>2</sup>, Yi-Li Chuang<sup>3</sup>, Hui-Sheng Lin<sup>4</sup>, and Tong-Yuan Tai<sup>1</sup>

<sup>1</sup> Division of Gerontology Research, National Health Research Institutes, Taipei, Taiwan.

<sup>2</sup> Division of Child and Adolescent Health, Bureau of Health Promotion, Department of Health, Taichung, Taiwan.

<sup>3</sup> Center for Population and Health Survey Research, Bureau of Health Promotion, Department of Health, Taichung, Taiwan.

<sup>4</sup> Department of Public Health, Chung Shan Medical University, Taichung, Taiwan.

Received for publication May 3, 2006; accepted for publication August 26, 2006.

Compared with the well-documented association with betel-related cancer, little is known about the long-term effect of areca nut chewing on other fatal diseases. The authors' analyses were based on a population-based cohort study in Taiwan, including 4,049 participants aged 60 years or older enrolled in 1989 and 2,462 participants aged 50–66 years enrolled in 1996. Information regarding betel quid chewing and covariates was collected at baseline and was updated at subsequent interviews. Proportional hazards analysis was performed to determine the effect of chewing on all-cause and cause-specific deaths. During a mean follow-up of 9.5 years, 2,309 deaths occurred. Ever chewers were at higher risk of only total (hazard ratio = 1.19, 95% confidence interval: 1.05, 1.35) and cerebrovascular (hazard ratio = 1.66, 95% confidence interval: 1.19, 2.30) deaths. Furthermore, increased chewing-years or quid-years appeared to be associated with increased mortality risk (linear trend:  $p = 0.02$  for total mortality and  $p = 0.001$  for cerebrovascular mortality). The authors found that, although betel quid chewing resulted in a statistically significant increase in the risk of total and cerebrovascular deaths in the elderly population, the associations were weak and should be interpreted with caution. Further studies are needed to confirm these findings and to better understand the possible mechanisms of death.

aged; areca; cohort studies; mortality

Areca nut chewing is an indigenous habit common in habitats of the tropical palm trees bearing the nut, notably in Central, South, and Southeast Asia, and some South Pacific islands (1). It is estimated that the habit is practiced by 200–600 million persons around the globe, accounting for 10–20 percent of the world's population (1, 2). With the growing number of immigrants from those areas, consumption of areca nut is increasing in western Europe and North America (2), where areca nut chewing, compared with tobacco use and alcohol intake, remains an underrecognized public health issue.

Across countries, areca nut is prepared in different ways from different forms of areca nut to betel quid—a mixture of areca nut and flavoring ingredients with or without processed tobacco leaves. For example, in India, Pakistan, Ban-

gladesh, and Sri Lanka, the fresh, dried, or cured areca nut is commonly chewed with slaked lime, some flavorings, and cut tobacco leaves or powder wrapped in betel leaf (1, 3). However, in Taiwan, the unripe areca nut is often chewed with slaked lime, sometimes together with betel inflorescence or betel leaf, but tobacco is not added (3, 4). Although areca nut or betel quid is used as a psychoactive substance (5), its carcinogenic effect has been observed in both animal and epidemiologic studies (6). In 2004, the International Agency for Research on Cancer confirmed areca nut and betel quid as human carcinogens with sufficient evidence of increased risk of precancerous oral fibrosis and cancer of the oral cavity, pharynx, and esophagus (3).

Except for cancer of the upper digestive tract, population-based studies examining the long-term association of areca

Correspondence to Dr. Tzuo-Yun Lan, Division of Gerontology Research, National Health Research Institutes, Room 4110, 4F, No. 161, Ming-Chuan East Road, Sec. 6, Taipei 114, Taiwan (e-mail: tytan@nhri.org.tw).

nut chewing with other types of cancer or other diseases have been relatively rare. Only a few cross-sectional surveys have attempted to examine the association between areca nut and psychological symptoms (5) or diabetes (7). A major reason is lack of cohort studies to facilitate longitudinal assessment of their causal relation and to eliminate the confounding effect of tobacco potentially existing in the study because areca nut is often chewed with tobacco (8, 9). It therefore remains unclear whether areca nut chewing has effects similar to those for cigarette smoking on the development of different diseases such as cardiovascular diseases (10). As mentioned, in Taiwan, betel quid is chewed without tobacco, which provides an opportunity to better understand the independent effect of betel quid on diseases (8, 9). Using nationwide health data, we previously identified the link between betel quid chewing and obesity (11), a predisposing factor for cardiovascular, metabolic, and other chronic diseases. In the present cohort study, we extended our analyses to prospectively examine the relations of betel quid chewing with total and cause-specific mortality.

## MATERIALS AND METHODS

### Study cohort

The Survey of Health and Living Status of the Near Elderly and Elderly in Taiwan, a prospective cohort study jointly funded by the US National Institute on Aging and the Taiwan government, was conducted by the Taiwan Provincial Institute of Family Planning (now incorporated into the Bureau of Health Promotion, Department of Health, Taiwan) and the Population Studies Center at the University of Michigan. The study began in 1989 with a sample of 4,049 persons aged 60 years or older. The sample was re-interviewed in 1993. In addition to elderly persons, the near-elderly population has grown into a crucial constituent of the rapidly aging society. Taking this factor into consideration, with its 1996 interview, the study was extended to include a sample of 2,462 persons aged 50–66 years. The interview was conducted again in 1999 so that all 6,511 study participants were interviewed at 3- to 4-year intervals. Both samples were drawn, through a three-stage probability sampling method (12, 13), from the entire elderly or near-elderly population of Taiwan. Data used in this analysis comprise four waves (1989, 1993, 1996, and 1999) of in-person interviews for the 1989 elderly cohort and two waves (1996 and 1999) for the 1996 near-elderly cohort.

### Betel quid chewing and covariates

In the initial interview, study participants were asked to report whether they chewed betel quid. Betel quid users were asked to provide information on starting age and average amount consumed daily. Former users were also asked their age at quitting. Those having tried chewing only one or two times in their lifetime were regarded as never chewers. A half quid per day was used to represent the amount of quid consumed per day for those who chewed less than one quid per day on average. Chewing status was updated in subsequent interviews throughout the study period so we could

calculate cumulative time and amount of chewing. Similar to pack-years or cigarette-years of smoking commonly used in smoking-related studies to evaluate long-term cumulative exposure, quid-years of chewing were calculated by multiplying the number of betel quids per day by the number of years of chewing reported at the last interview.

Other information collected at baseline through a pre-designed, pretested questionnaire included age, sex, living area as an indicator of geographic variations in social and health status, functional status, and selected history of chronic conditions reported by the physicians. Similar items in follow-up questionnaires were used to update information. Because questions regarding difficulties in daily functioning activities were not consistent across interviews, difficulty in bathing was used as the indicator of functional status. In addition, information regarding cigarette smoking and alcohol intake was also considered because use of these substances may confound the relation between betel quid chewing and diseases or mortality (4, 14).

To better control these confounders in the survival analyses, we used, in addition to smoking and drinking status, cumulative pack-years of smoking and average weekly ethanol consumption to quantify the use of cigarettes and alcohol. Cumulative pack-years of smoking were calculated as average daily use of cigarettes across interviews multiplied by cumulative smoking-years divided by 20. Level of cigarette smoking was further grouped into five categories: never, low (<12 pack-years), middle (12–36 pack-years), high (>36 pack-years), and ever smokers without detailed smoking information.

Average weekly ethanol consumption was defined as the average amount of ethanol consumed weekly across interviews. Because ethanol content is determined by both beverage type (4.5 percent in beer, 12 percent in wine, 40 percent in liquor, and 8 percent in Chinese medicinal wine) and unit per drink (600 ml in a large bottle, 300 ml in a small bottle, 350 ml in a can, 120 ml in a large glass, and 20 ml in a small glass), weekly ethanol amount for a consumed beverage was calculated as follows: ethanol content for the beverage  $\times$  total amount for each type consumed  $\times$  frequency per week. The weekly ethanol amounts for different consumed beverages were then added to produce weekly ethanol consumption. Similarly, level of ethanol consumption was categorized as never, low (<10 ml of ethanol), middle (10–85 ml of ethanol), high (>85 ml of ethanol), and ever drinkers without detailed drinking information.

### Outcome measures

Deaths that occurred between the initial interviews in 1989 for the elderly cohort and 1996 for the near-elderly cohort and December 31, 2003, were reported by families of study participants at subsequent interviews and were confirmed by the national death registry at the Department of Health, Taiwan, from which detailed information about the death, including the dates and major causes, was also obtained. Causes of death were classified by using the coding system of the *International Classification of Diseases, Ninth Revision, Clinical Modification* (15). In the analysis, all causes of death were grouped into cancer, diabetes,

TABLE 1. Characteristics of the study cohort at baseline\* according to betel quid chewing status, Taiwan, 1989 and 1996

Characteristic	Betel quid chewing status								p value†
	Never chewer (n = 5,602)		Ever chewer (n = 901)				Total		
	No.	%	Former chewer (n = 373)	%	Current chewer (n = 528)	%	No.	%	
Sex: male	2,839	50.7	331	88.7	407	77.1	738	81.9	<0.001
Age in years (mean (standard deviation))	64.6 (7.7)		63.0 (8.1)		61.6 (7.0)		62.2 (7.5)		<0.001
Living area									<0.001
North	1,702	30.4	63	16.9	57	10.8	120	13.3	
Central	1,814	32.4	145	38.9	178	33.7	323	35.8	
South and east	2,086	37.2	165	44.2	293	55.5	458	50.8	
Medical history									
Hypertension	1,398	25.1	82	22.0	104	19.7	186	20.7	0.004
Anemia	469	8.4	22	5.9	33	6.3	55	6.1	0.02
Heart disease	998	17.9	38	10.2	60	11.4	98	10.9	<0.001
Liver disease	310	5.5	28	7.5	40	7.6	68	7.6	0.02
Arthritis	1,402	25.1	59	15.8	112	21.3	171	19.0	<0.001
Smoking status									
Current or former smoker	2,192	39.2	328	87.9	423	80.3	751	83.4	<0.001
Alcohol intake									
Current or former drinker	1,798	32.2	264	70.8	330	62.6	594	66.0	<0.001
Physical function									
Has difficulty	264	4.7	17	4.6	12	2.3	29	3.2	0.04

\* For the pooled cohort at baseline, we included data for 4,049 subjects aged 60 years or older collected in 1989 and for 2,462 subjects aged 50–66 years collected in 1996.

† p values represent differences between the never and the ever betel quid chewers.

cardiovascular conditions, liver cirrhosis, respiratory conditions, and other causes. Some of these groups were further classified into subgroups. Cancer was divided into oral cavity and esophagus, stomach, liver, lung, and others. Cardiovascular conditions were divided into coronary heart disease, cerebrovascular disease, and others. Respiratory conditions were categorized as pneumonia and chronic obstructive pulmonary disease. These groups or subgroups were the main causes of death commonly seen in Taiwan in recent years (16).

### Statistical analysis

In the descriptive analysis of baseline information and chewing status, frequency distributions for categorical variables or means plus standard deviations for continuous variables were used. A chi-square test or independent *t* test, as appropriate, was used to compare never chewers with ever chewers. Survival data were modeled with Cox proportional hazards regressions to estimate hazard ratios associated with groups of deaths from different causes among groups of chewers. The assumption of proportional hazards, the constant hazard ratio or proportionality of hazards from one case to another over time, was tested graphically. The log survival probabilities plot stratified by chewing status showed two separate lines, indicating no violation of the

assumption. Results were consistent across the two cohorts in the models; the data were therefore combined.

In addition to age- and sex-adjusted models, multivariate models were also adopted to assess confounding in the association between betel quid and mortality with the adjustment of covariates that had previously been tested with significant differences between never- and ever-chewer groups in the descriptive analysis. Curves for overall survival were estimated by the Kaplan-Meier method (17). Cumulative years and quid-years of chewing, stratified into groups, were further used to examine the dose-response relation. Because 247 ever chewers were either uncertain about or failed to provide the exact number of quids per day, a category listed as "missing" was added in the analysis of quid-years of chewing. A test for trend was also conducted by treating cumulative chewing-years and quid-years of chewing as a continuous variable. *p* values for all tests were two tailed, and statistical differences were considered at the <0.05 level. All analyses were performed by using SPSS version 12 software (SPSS Inc., Chicago, Illinois).

### RESULTS

For the 6,511 study participants enrolled, information on betel quid chewing was provided for 6,503 at baseline. At baseline (table 1), about 13.9 percent reported having a betel

TABLE 2. Numbers of deaths and hazard ratios\* by cause of death and betel quid chewing status,† Taiwan, 1989 and 1996

Cause of death (ICD-9‡ code(s))	Betel quid chewing status								
	Never chewer (n = 5,586)			Ever chewer (n = 917)					
	No. of deaths	HR‡	No. of deaths	HR§	95% CI‡	p value	HR¶	95% CI	p value
Cancer (140–208)	418	1.00	71	1.10	0.85, 1.43	0.45	1.03	0.78, 1.34	0.86
Oral cavity and esophagus (140–150)	27	1.00	10	1.95	0.93, 4.11	0.08	1.60	0.73, 3.54	0.24
Stomach (151)	51	1.00	6	0.79	0.34, 1.86	0.59	0.78	0.32, 1.90	0.59
Liver (155)	79	1.00	10	0.69	0.35, 1.35	0.28	0.61	0.30, 1.27	0.19
Lung (162)	85	1.00	19	1.38	0.83, 2.29	0.21	1.15	0.68, 1.95	0.60
Other	176	1.00	26	1.09	0.72, 1.66	0.68	1.10	0.71, 1.72	0.673
Diabetes (250)	161	1.00	23	1.18	0.75, 1.84	0.47	1.14	0.71, 1.84	0.579
Cardiovascular conditions (390–459)	582	1.00	102	1.36	1.10, 1.69	0.004	1.41	1.12, 1.77	0.003
Coronary heart disease (410–414)	134	1.00	19	1.10	0.67, 1.78	0.71	1.22	0.73, 2.04	0.45
Cerebrovascular disease (430–439)	254	1.00	51	1.52	1.12, 2.06	0.008	1.66	1.19, 2.30	0.003
Other	194	1.00	32	1.35	0.92, 1.97	0.13	1.18	0.79, 1.78	0.41
Liver cirrhosis (571)	40	1.00	10	1.62	0.79, 3.31	0.19	1.69	0.78, 3.63	0.18
Respiratory conditions (460–519)	227	1.00	39	1.23	0.88, 1.74	0.23	1.22	0.85, 1.75	0.28
Pneumonia (480–486, 507)	100	1.00	17	1.29	0.77, 2.17	0.34	1.42	0.82, 2.47	0.22
Chronic obstructive pulmonary disease (490–496)	99	1.00	18	1.23	0.74, 2.04	0.43	1.11	0.65, 1.88	0.71
All other causes	554	1.00	82	1.18	0.93, 1.49	0.17	1.08	0.84, 1.38	0.54
Total	1,982	1.00	327	1.24	1.10, 1.39	<0.001	1.19	1.05, 1.35	0.007

\* Hazard ratios are from a Cox proportional hazards model.

† Chewing status was measured throughout the last interview.

‡ ICD-9, *International Classification of Diseases*, Ninth Revision; HR, hazard ratio; CI, confidence interval.

§ Adjusted for age and sex.

¶ Adjusted for sex, age at baseline, living area, and the following factors updated until the last interview: presence or absence of hypertension, anemia, heart disease, liver disease, arthritis, and physical difficulty; and levels of cigarette smoking and alcohol intake.

quid chewing habit currently or in the past. Compared with never chewers, ever chewers were more likely to be men, be younger, live in southern and eastern areas, and have liver disease but were less likely to have hypertension, anemia, heart disease, arthritis, and physical difficulty. Chewers also tended to be cigarette smokers and alcohol users. A total of 2,309 deaths occurred during follow-up, including 489 from cancer, 184 from diabetes, 684 from cardiovascular conditions, 50 from liver cirrhosis, 266 from respiratory conditions, and 636 from other causes. The average follow-up period was 9.5 years (standard deviation, 4.2), with 10.9 years (standard deviation, 4.7) for the 1989 cohort and 7.2 years (standard deviation, 1.3) for the 1996 cohort.

Only a borderline significant association was detected between chewing status and cancer of the oral cavity and esophagus, with adjustment for age and sex. However, this weak association disappeared after adding other covariates, including living area, hypertension, anemia, heart disease, liver disease, arthritis, physical difficulty, cigarette smoking, and alcohol intake. Ever chewers were at a significantly higher risk than never chewers of dying from cardiovascular conditions, cerebrovascular disease, and all causes, both when age and sex and when age and sex together with other confounding factors were considered in the models

(table 2). The significant risk of cardiovascular conditions was fully attributable to cerebrovascular disease because the risk of other subgroups of cardiovascular conditions was not significant.

Figure 1 shows the Kaplan-Meier estimates of time of death or the end of follow-up for the two cohorts. The probabilities of survival for the 1989, 1996, and combined cohorts were significantly lower for ever chewers than for never chewers. The *p* values for the log-rank test were 0.003, 0.033, and less than 0.001, respectively. Similar results were also observed for death from cerebrovascular disease; *p* values were 0.003, 0.049, and 0.005, respectively.

The hazard ratios of total death and death from cerebrovascular disease according to level of betel quid consumption in years are shown in table 3. After adjustment for confounders, betel quid chewing-years was associated with both total (*p* = 0.02 for trend) and cerebrovascular (*p* = 0.001 for trend) mortality. A significant increase in the risk was observed for chewers who had chewed for 25–39 years and for 40 years or longer when never chewers (chewing year = 0) were considered the reference group. Similarly, quid-years of chewing was related to death from all causes (*p* = 0.02 for trend) and cerebrovascular disease (*p* = 0.001 for trend) after the same adjustment. There was

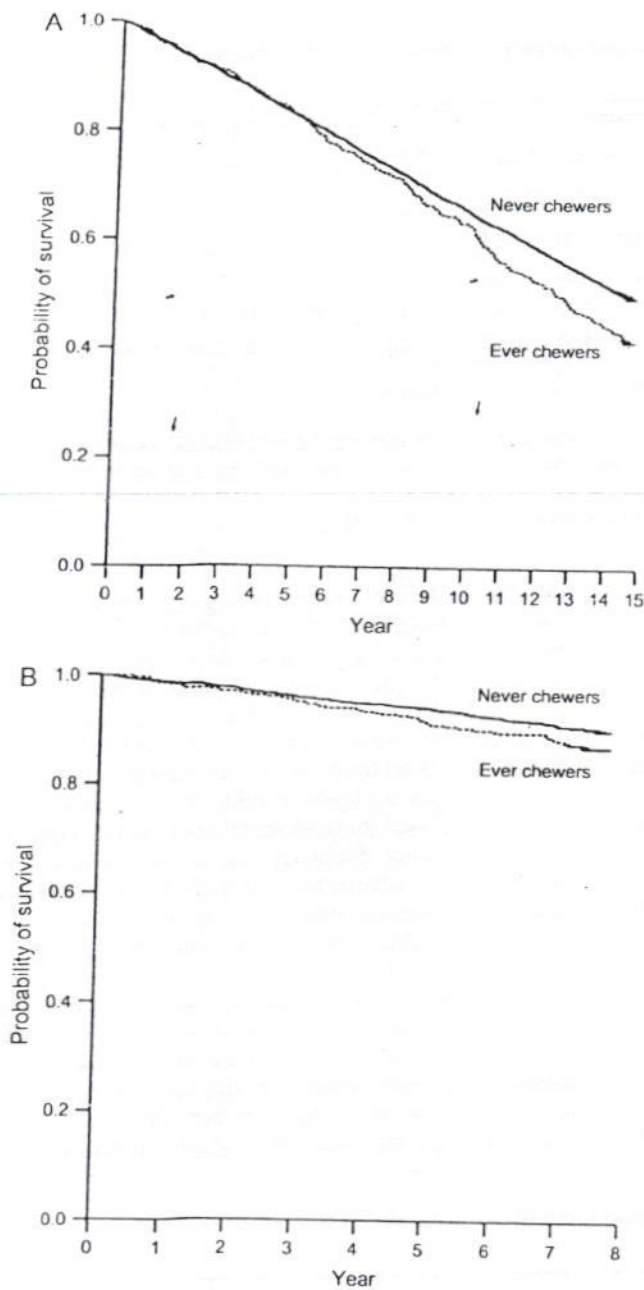

FIGURE 1. Kaplan-Meier estimates of survival for the 1989 cohort (A) and 1996 cohort (B) of study subjects according to betel quid chewing status, Taiwan.

a significantly increased risk for chewers with 350 quid-years or more of chewing (table 4).

**DISCUSSION**

In this population-based cohort study in Taiwan, we found betel quid chewing to be associated with mortality from all causes and cerebrovascular disease, but not with

mortality from cancer and other causes among near-elderly and elderly persons. Our results also showed dose-response relations in which the increased risks were mainly for chewers who chewed for 25 years or for 350 quid-years or longer compared with those who never chewed. Overall, our findings may provide new evidence linking elevated mortality risk with long-term betel quid chewing.

Betel-related cancer, mainly including that of the oral cavity, pharynx, and esophagus, usually occurs in persons aged 45–65 years. The 5-year survival rate varies from 6 percent to 10 percent for esophagus cancer to 40–50 percent for oral cancer (18). In Taiwan, results from several studies have indicated that betel quid chewers who had these cancers were significantly younger than nonchewers (9). For example, the mean age of oral cancer patients with a betel quid chewing habit was 50 years, more than 10 years younger than patients without the habit (19). Betel quid chewers also reported a poorer prognosis, yielding a significantly lower survival rate than for nonchewers (19). Moreover, the effect of chewing on oral-related cancer was significantly strong in persons aged 50 years or younger, suggesting a relatively lower risk for those who were older (20). These characteristics of early age at onset, low survival rate, and different age susceptibility for betel quid chewers probably explain why mortality from cancer, especially betel-related cancer, was not associated with betel quid chewing in our study, because we observed only near-elderly and elderly persons.

Betel quid chewers who might have escaped the risk of betel-related cancer and reached older age, however, were not free from other diseases. In our study, they were at a relatively higher risk of death in later life from either all causes or cerebrovascular diseases. Of course, it is curious and crucial to understand why long-term chewing of betel quid is linked with cerebrovascular diseases, including stroke. Betel quid consumed without tobacco consists, in addition to areca nut, of a complex range of accompaniments covering slaked lime, betel leaf, spices, sweeteners, inflorescence, and/or catechu. Chewing these materials results in exposure to areca nut alkaloids (mainly arecoline and arecaidine), polyphenols, tannin, trace elements (e.g., copper), areca-nut-derived nitrosamines that have been found in chewers' saliva, and other chemicals.

Most of these chemicals' relations with diseases have yet to be identified. Some studies have attempted to unravel the exact mechanisms involved in oral cancer (6) or obesity (21). As noted previously, the association of areca nut chewing with obesity and diabetes has been observed cross-sectionally. It is possible that the contribution of areca nut chewing to cardiovascular, mainly cerebrovascular, death lies in the fact that some of the chemicals from alkaloids may trigger increased appetite and glucose intolerance (7, 11), which in turn lead to obesity, diabetes, and subsequent death from cardiovascular conditions. The detailed mechanism by which the chemicals singly or jointly induce the specific disease remains unclear and merits further investigation.

On the other hand, the possible cause may have no direct link to these chemicals of betel quid. In recent years, increasing attention has been paid to investigating periodontal disease and its association with cardiovascular conditions,

1041

**TABLE 3. Hazard ratios of total and cerebrovascular mortality by cumulative years of betel quid chewing,\* Taiwan, 1989 and 1996**

No. of years of chewing	Total mortality				Cerebrovascular mortality			
	No. of deaths	HR†,‡	95% CI†	p value	No. of deaths	HR†	95% CI	p value
Never chewer (n = 5,586)	1,982	1.00		0.02§	254	1.00		0.001§
1-9 (n = 207)	69	1.18	0.93, 1.51	0.18	9	1.27	0.65, 2.51	0.48
10-24 (n = 204)	58	1.01	0.77, 1.32	0.95	6	0.95	0.42, 2.16	0.90
25-39 (n = 259)	80	1.28	1.02, 1.62	0.04	14	2.05	1.17, 3.59	0.01
≥40 (n = 247)	120	1.25	1.03, 1.51	0.02	22	2.10	1.33, 3.32	0.002

\* Chewing-years for chewers were categorized based on a quartile distribution.

† HR, hazard ratio; CI, confidence interval.

‡ Adjusted for sex, age at baseline, living area, and the following factors updated until the last interview: presence or absence of hypertension, anemia, heart disease, liver disease, arthritis, and physical difficulty; and levels of cigarette smoking and alcohol intake.

§ p values are for linear trend across all categories of years of betel quid chewing.

especially cerebrovascular events (22, 23). For example, the results of a meta-analysis of nine cohort studies indicate that the relative risks of future cardiovascular events and stroke for persons with periodontal disease were 1.44 and 2.85, respectively (24). Periodontal disease has also been linked with betel quid chewing. In Taiwan, a significantly higher prevalence of periodontal problems was observed in betel quid chewers than in nonchewers (25), suggesting that betel quid chewers may be at a higher risk of chronic microbial infection (e.g., subgingival infection) that can lead to subsequent cerebrovascular events (26).

Our study finds its major strengths in its ability to control tobacco use and other potential confounders, to perform a substantial and complete mortality follow-up for as long as 14 years, and to make available the responses to a repeated questionnaire that helped to assess the continuous conditions of betel quid chewing and other covariates.

Some methodologic issues should be considered when interpreting the results. First, although the number of study participants was large, the low prevalence of betel quid

chewing in the older population, partly due to the survival effect, may have resulted in an underestimate of the association with mortality. Second, some values for betel quid amount in the analysis of quid-years and mortality were missing, which inevitably reduced the power to evaluate the association. Third, measurement errors in self-reported questions of betel quid chewing as well as other health information, such as chronic conditions included in the study, might have biased the association between betel quid chewing and mortality. Similarly, our results could have been influenced by inaccuracies in identifying the primary cause of death. However, previous reviews found that death certificates and codes in the national death registry files were in overall agreement (27).

Fourth, certain health-related factors that could also affect chewing habits and other objective measures of physiological conditions, such as blood pressure and biochemical indicators, were not included in the study, which may also have biased the estimation of mortality hazard. Finally, our study was originally designed to understand factors

**TABLE 4. Hazard ratios of total and cerebrovascular mortality by quid-years of betel quid chewing,\* Taiwan, 1989 and 1996**

No. of quid-years of chewing	Total mortality				Cerebrovascular mortality			
	No. of deaths	HR†,‡	95% CI†	p value	No. of deaths	HR†	95% CI	p value
Never chewer (n = 5,586)	1,982	1.00		0.02§	254	1.00		0.001§
<50 (n = 222)	62	1.11	0.85, 1.43	0.45	7	1.09	0.51, 2.35	0.83
50-349 (n = 224)	68	1.18	0.92, 1.52	0.19	7	1.17	0.54, 2.52	0.69
≥350 (n = 224)	82	1.31	1.04, 1.64	0.02	16	2.43	1.42, 4.16	0.001
Ever chewer with no quid information (n = 247)	115	1.17	0.97, 1.42	0.11	21	1.79	1.13, 2.84	0.01

\* Chewing-years for chewers were categorized based on a tertile distribution.

† HR, hazard ratio; CI, confidence interval.

‡ Adjusted for sex, age at baseline, living area, and the following factors updated until the last interview: presence or absence of hypertension, anemia, heart disease, liver disease, arthritis, and physical difficulty; and levels of cigarette smoking and alcohol intake.

§ p values are for linear trend across all categories of quid-years of betel quid chewing except the category of "Ever chewer with no quid information."

1642

associated with general health and living arrangements, not to determine mortality risks. Our data therefore could not fully control for all potential factors affecting mortality, including diet. As a result, we cannot rule out the possibility of residual confounding by factors that were not evaluated or were not adequately measured or controlled.

In conclusion, these prospective data represent the first report, to our knowledge, from a population-based study of the impact of exposure to betel quid consumption on mortality from different causes. Betel quid chewing is associated with total and cerebrovascular mortality among middle-to-old-aged ever chewers. These data also suggest that the effects of betel quid chewing on mortality from all causes and cerebrovascular disease may be cumulative. Nonetheless, we need to be cautious when interpreting these results because the significant, but weak associations still leave room for some skepticism, including possible bias from random error or misclassification. Obviously, more investigations, preferably with a larger sample size and longer follow-up time, are needed to further clarify our findings.

#### ACKNOWLEDGMENTS

The Survey of Health and Living Status of the Near Elderly and Elderly in Taiwan was supported by funding from the US National Institute on Aging; the Department of Health, Taiwan; and the National Health Research Institutes, Taiwan.

The authors are indebted to Yu-Hsuan Lin, Dr. Tony Liang, and Bob Hsu for their comments on an earlier draft of this paper.

This study was based on data from the Survey of Health and Living Status of the Near Elderly and Elderly in Taiwan provided by the Population and Health Research Center, Bureau of Health Promotion. The interpretation and conclusions contained herein do not represent those of authors' affiliations.

Conflict of interest: none declared.

#### REFERENCES

- Gupta PC, Warnakulasuriya S. Global epidemiology of areca nut usage. *Addict Biol* 2002;7:77-83.
- Trivedy C, Warnakulasuriya S, Peters TJ. Areca nuts can have deleterious effects. (Letter). *BMJ* 1999;318:1287.
- Betel-quid and areca-nut chewing and some areca-nut-derived nitrosamines. IARC monographs on the evaluation of carcinogenic risks to humans. Vol 85. Lyon, France: International Agency for Research on Cancer, 2004.
- Wen CP, Tsai SP, Cheng TY, et al. Uncovering the relation between betel quid chewing and cigarette smoking in Taiwan. *Tob Control* 2005;14(suppl 1):i16-22.
- Winstock AR, Trivedy CR, Warnakulasuriya S, et al. A dependency syndrome related to areca nut use: some medical and psychological aspects among areca nut users in the Gujarat community in the UK. *Addict Biol* 2000;5:173-9.
- Jeng JH, Chang MC, Hahn LJ. Role of areca nut in betel quid-associated chemical carcinogenesis: current awareness and future perspectives. *Oral Oncol* 2001;37:477-92.
- Tung TH, Chiu YH, Chen LS, et al. A population-based study of the association between areca nut chewing and type 2 diabetes mellitus in men (Keelung Community-based Integrated Screening programme No. 2). *Diabetologia* 2004;47:1776-81.
- Warnakulasuriya S, Trivedy C, Peters TJ. Areca nut use: an independent risk factor for oral cancer. (Editorial). *BMJ* 2002;324:799-800.
- Wu MT, Lee YC, Chen CJ, et al. Risk of betel chewing for oesophageal cancer in Taiwan. *Br J Cancer* 2001;85:658-60.
- Howard G, Wagenknecht LE, Burke GL, et al. Cigarette smoking and progression of atherosclerosis: The Atherosclerosis Risk in Communities (ARIC) Study. *JAMA* 1998;279:119-24.
- Chang WC, Hsiao CF, Chang HY, et al. Betel nut chewing and other risk factors associated with obesity among Taiwanese male adults. *Int J Obes (Lond)* 2006;30:359-63.
- Population Studies Center. 1989 survey of health and living status of the elderly in Taiwan: questionnaire and survey design. Ann Arbor, MI: Population Studies Center, University of Michigan, 1989. (Comparative study of the elderly in Asia report no. 89-1).
- Zimmer Z, Martin LG, Chang MC. Changes in functional limitation and survival among older Taiwanese, 1993, 1996, and 1999. *Popul Stud (Camb)* 2002;56:265-76.
- Ko YC, Chiang TA, Chang SJ, et al. Prevalence of betel quid chewing habit in Taiwan and related sociodemographic factors. *J Oral Pathol Med* 1992;21:261-4.
- Department of Health and Human Services. The international classification of diseases. Ninth Revision. Clinical modification: ICD-9-CM. Vol 1. Diseases: tabular list. Washington, DC: Government Printing Office, 1980. (DHHS publication no. (PHS) 80-1269).
- Department of Health. Summary of statistics on causes of death in Taiwan. Taipei, Taiwan: Department of Health, Taiwan, 1994.
- Kalbfleisch JD, Prentice RL. The statistical analysis of failure time data. New York, NY: John Wiley, 1980.
- National Cancer Institute. SEER cancer statistics review, 1973-1996. Bethesda, MD: National Cancer Institute, 1999.
- Lee JJ, Jeng JH, Wang HM, et al. Univariate and multivariate analysis of prognostic significance of betel quid chewing in squamous cell carcinoma of buccal mucosa in Taiwan. *J Surg Oncol* 2005;91:41-7.
- Sankaranarayanan R, Duffy SW, Padmakumary G, et al. Risk factors for cancer of the buccal and labial mucosa in Kerala, southern India. *J Epidemiol Community Health* 1990;44:286-92.
- Johnston GA, Krosgaard-Larsen P, Stephanson A. Betel nut constituents as inhibitors of gamma-aminobutyric acid uptake. *Nature* 1975;258:627-8.
- Joshiyura KJ, Hung HC, Rimm EB, et al. Periodontal disease, tooth loss, and incidence of ischemic stroke. *Stroke* 2003;34:47-52.
- Pihlstrom BL, Michalowicz BS, Johnson NW. Periodontal diseases. *Lancet* 2005;366:1809-20.
- Janket SJ, Baird AE, Chuang SK, et al. Meta-analysis of periodontal disease and risk of coronary heart disease and stroke. *Oral Surg Oral Med Oral Pathol Oral Radiol Endod* 2003;95:559-69.
- Ling LJ, Hung SL, Tseng SC, et al. Association between betel quid chewing, periodontal status and periodontal pathogens. *Oral Microbiol Immunol* 2001;16:364-9.
- Pussinen PJ, Alfthan G, Rissanen H, et al. Antibodies to periodontal pathogens and stroke risk. *Stroke* 2004;35:2020-3.
- Lu TH, Lee MC, Chou MC. Accuracy of cause-of-death coding in Taiwan: types of miscoding and effects on mortality statistics. *Int J Epidemiol* 2000;29:336-43.

1043 R

Approved 1/2

# Betel nut chewing is associated with increased risk of cardiovascular disease and all-cause mortality in Taiwanese men<sup>1,2</sup>

Wen-Yuan Lin, Tai-Yuan Chiu, Long-Teng Lee, Cheng-Chieh Lin, Chih-Yang Huang, and Kuo-Chin Huang

## ABSTRACT

**Background:** Betel nut chewing is related to several kinds of cancer, metabolic syndrome, and type 2 diabetes. Whether it is associated with a greater risk of cardiovascular disease (CVD) and all-cause mortality, however, remains unclear.

**Objective:** We aimed to investigate the association between betel nut chewing and CVD and all-cause mortality.

**Design:** A baseline cohort of 56 116 male participants  $\geq 20$  y old were recruited from 4 nationwide health screening centers in Taiwan in 1998 and 1999. Cox proportional hazards regression analyses were used to estimate the relative risks (RRs) of CVD and all-cause mortality for betel nut chewers during an 8-y follow-up period.

**Results:** There were 1549 deaths during the follow-up period, 309 of which were due to CVD. After adjustment for age, body mass index, diabetes, hypertension, lipids, smoking, alcohol consumption, physical activity, income, and education level, the RRs (95% CI) of CVD and all-cause mortality among the former betel nut chewers were 1.56 (1.02, 2.38) and 1.40 (1.17, 1.68), respectively, and those among current chewers were 2.02 (1.31, 3.13) and 1.40 (1.16, 1.70), respectively, compared with persons who had never chewed betel nut. Current and former betel nut chewers had a higher risk of CVD mortality (RR: 2.10;  $P < 0.05$ ) than did current and former smokers. Greater frequency of betel nut chewing was associated with greater CVD and all-cause mortality.

**Conclusions:** Betel nut chewing was independently associated with a greater risk of CVD and all-cause mortality in Taiwanese men. Regular screening for betel nut chewing history may help prevent excess deaths in the future. An anti-betel nut chewing program is urgently warranted for current chewers. *Am J Clin Nutr* 2008; 87:1204–11.

## INTRODUCTION

Betel nut (*Areca catechu*) is the fourth most widely used addictive substance in the world. Betel nut chewers now make up  $\geq 10\%$  of the world's population (1, 2). There are many different ways to prepare betel nut. For example, in South Asia, people chew the fresh, dried, or cured betel nuts with slaked lime, betel leaf (*Piper betle* vine), and tobacco leaves (2, 3). In Taiwan, however, people chew betel nuts in combination with *P. betle* (inflorescence or leaf) and lime but without tobacco leaves (3, 4). Four main arecal alkaloids (ie, arecoline, arecaidine, guvacine, and guvacoline) are absorbed during betel nut chewing (1). The arecal alkaloids have been shown to be inhibitors of  $\gamma$ -aminobutyric acid receptor and also to have many physiologic and metabolic effects on the brain, cardiovascular system, lung, gut, and pancreas (1).

Betel nut chewing is linked not only to the development of oral and esophageal cancer, hepatocellular carcinoma, and liver cirrhosis (1, 5–10) but also to obesity, type 2 diabetes, hypertension, hyperlipidemia, metabolic syndrome, and chronic kidney disease (11–16). However, it is unclear whether betel nut chewing is associated with cardiovascular disease (CVD), which is one of the leading causes of death worldwide (17). In Taiwan, the prevalence of betel nut chewing is as high as 16.9% (31% in men and 2.4% in women, respectively) (15). Until now, however, there has been no study of the long-term effect of betel nut chewing on CVD and all-cause mortality. Therefore, we investigated the association between betel nut chewing and CVD and all-cause mortality in a large Taiwanese cohort.

## SUBJECTS AND METHODS

### Subjects and measurements

The data were collected from 4 private nationwide MJ Health Screening Centers in Taiwan in 1998 and 1999. The registered health practitioners in these centers provide a multidisciplinary team approach to the health assessment of their members. Most of the members undergo a health examination every 3–4 y, and  $\approx 30\%$  of them will receive the same health check-up every year. A total of 58 771 male adults  $\geq 20$  y old, out of 124 513 subjects, were recruited into the study; female betel nut chewers were excluded because the prevalence of betel nut chewing in women was very low (0.46%). Among the 58 771 male adults, 2655 did not complete the items pertaining to betel nut chewing habits on the questionnaire. Therefore, the baseline cohort analyzed in the study comprised 56 116 participants. The population structure in

<sup>1</sup> From the Department of Family Medicine, China Medical University Hospital, Taichung, Taiwan (W-YL and C-CL); the Department of Family Medicine and the Graduate Institute of Clinical Medical Science (W-YL and C-CL) and the Graduate Institute of Basic Medical Science (C-YH), College of Medicine, China Medical University, Taichung, Taiwan; the Department of Family Medicine, National Taiwan University Hospital, Taipei, Taiwan (W-YL, T-YC, L-TL, and K-CH); and the Institute of Health Care Administration, College of Health Science, Asia University, Taichung, Taiwan (C-CL).

<sup>2</sup> Address reprint requests to K-C Huang, Department of Family Medicine, National Taiwan University Hospital, 7 Chung-Shan South Road, Taipei, Taiwan 100. E-mail: brethuang@ntu.edu.tw.  
Received September 2, 2007.

Accepted for publication January 8, 2008.

The American Journal of Clinical Nutrition



1044

our study was similar to the national data for adult males published by the Taiwanese government (18). Deaths were ascertained by computer linkage to the national death registry by using identification numbers. All deaths that occurred between study entry and December 2005 were included. Deaths with International Classification of Disease, Ninth Revision (ICD-9) codes 390–459 were classified as CVD deaths (19).

Anthropometric characteristics, blood pressure, and plasma fasting glucose and lipid concentrations were measured and were described in an earlier report (20). In brief, trained staff measured the height (to the nearest 0.1 cm) and weight (to the nearest 0.1 kg) of each participant by using an autoanthropometer (KN-5000A; Nakamura, Tokyo, Japan). Waist circumference was measured (to the nearest 0.1 cm) at the midway point between the inferior margin of the last rib and iliac crest in a horizontal plane by using a nonstretchable tape. Body mass index (BMI; in kg/m<sup>2</sup>) was calculated. The blood pressure (BP) was measured in the right arm of a seated participant by using an appropriately sized

cuff and a standard mercury sphygmomanometer after participants had ≥5 min of rest. Blood was drawn with minimal trauma from an antecubital vein in the morning after a 12-h overnight fast (20). Diabetes was defined as a fasting glucose concentration ≥ 7.0 mmol/L and a history of diabetes or of taking oral hypoglycemic agents or insulin (or both). Hypertension was defined as systolic BP ≥ 140 mm Hg or diastolic BP ≥ 90 mm Hg (or both) and a history of hypertension or of taking antihypertensive drugs (or both).

All patients provided written informed consent. Approval for patient recruitment and data analyses was obtained from the MJ Research Foundation Review Committee in Taiwan.

**Questionnaire**

Betel nut chewing, cigarette smoking, alcohol consumption, and physical activity histories were recorded for each subject from a questionnaire. Current, former, and never users were defined as those who reported the current use, any prior use, and

**TABLE 1**  
Baseline characteristics by status of betel nut chewing

	Betel nut chewing			P
	Never (n = 44 565)	Former (n = 5568)	Current (n = 5983)	
Age (y) <sup>2</sup>	43.4 ± 14.3 <sup>1</sup>	40.4 ± 12.5	40.1 ± 11.6	<0.001
Height (cm) <sup>2</sup>	168.6 ± 6.3	168.6 ± 6.2	168.5 ± 6.1	0.922
Body weight (kg) <sup>2</sup>	67.3 ± 10.3	68.6 ± 11.3	68.8 ± 11.1	<0.001
BMI (kg/m <sup>2</sup> ) <sup>2</sup>	23.7 ± 3.2	24.1 ± 3.6	24.2 ± 3.5	<0.001
WC (cm) <sup>2</sup>	81.6 ± 9.7	82.5 ± 10.1	82.8 ± 9.7	<0.001
Systolic BP (mm Hg) <sup>2</sup>	123.3 ± 17.7	122.2 ± 17.4	121.9 ± 17.7	<0.001
Diastolic BP (mm Hg) <sup>2</sup>	75.5 ± 11.3	75.6 ± 11.4	75.8 ± 11.8	<0.001
Fasting glucose (mg/dL) <sup>2</sup>	100.2 ± 22.7	101.5 ± 28.9	101.5 ± 28.9	0.312
TCHOL (mg/dL) <sup>2</sup>	203.1 ± 37.8	203.4 ± 40.2	200.5 ± 40.0	<0.001
Triacylglycerol (mg/dL) <sup>2</sup>	136.6 ± 105.1	160.9 ± 158.9	180.8 ± 187.8	<0.001
HDL-C (mg/dL) <sup>2</sup>	43.5 ± 14.1	41.5 ± 15.0	41.3 ± 16.5	<0.001
Diabetes [n (%)] <sup>4</sup>	2225 (5.0)	330 (5.9)	306 (5.1)	0.012
Hypertension [n (%)] <sup>4</sup>	9876 (22.2)	1090 (19.6)	1191 (19.9)	<0.001
Alcohol drinking [n (%)] <sup>4</sup>				<0.001
Never	30 513 (71.3)	2111 (39.7)	1833 (32.4)	<0.001
Former	2054 (4.8)	685 (12.9)	231 (4.1)	
Current	10 238 (23.9)	2522 (47.4)	3587 (63.5)	
Smoking [n (%)] <sup>4</sup>				<0.001
Never	24 682 (56.7)	567 (10.5)	573 (10.0)	<0.001
Former	5204 (12.0)	1064 (19.7)	376 (6.6)	
Current	13 626 (31.3)	3770 (69.8)	4783 (83.4)	
Physical activity [n (%)] <sup>4</sup>				<0.001
None or mild	18 010 (41.8)	2857 (54.8)	3263 (59.6)	<0.001
Moderate	17 235 (40.0)	1632 (31.3)	1601 (29.3)	
Vigorous	7805 (18.1)	721 (13.8)	609 (11.1)	
Income [n (%)] <sup>4</sup>				<0.001
Low	12 150 (28.3)	1900 (35.8)	1861 (33.0)	<0.001
Middle	25 884 (60.3)	3051 (57.6)	3379 (59.9)	
High	4857 (11.4)	350 (6.6)	402 (7.1)	
Education [n (%)] <sup>4</sup>				<0.001
Low	6198 (14.1)	1082 (19.8)	1242 (21.3)	<0.001
Middle	12 874 (29.3)	2953 (54.2)	3412 (58.5)	
High	24 826 (56.6)	1416 (26.0)	1176 (20.2)	

<sup>1</sup> WC, waist circumference; BP, blood pressure; TCHOL, total cholesterol; HDL-C, HDL cholesterol.

<sup>2</sup> ANOVA was used for comparing mean values of continuous variables between groups.

<sup>3</sup>  $\bar{x} \pm SD$  (all such values).

<sup>4</sup> Pearson chi-square test was used for categorical data.

1045  
R

**TABLE 2**  
Baseline characteristics by survival status and causes of death<sup>1</sup>

	Survivors (n = 54 567)	CVD deaths (n = 309)	All-cause death (n = 1549)
Age (y) <sup>2</sup>	42.2 ± 13.6 <sup>4</sup>	64.5 ± 12.3 <sup>4</sup>	62.0 ± 13.4 <sup>4</sup>
Height (cm) <sup>2</sup>	168.7 ± 6.2	164.7 ± 6.1 <sup>4</sup>	165.1 ± 6.1 <sup>4</sup>
Body weight (kg) <sup>2</sup>	67.7 ± 10.4	65.4 ± 10.7 <sup>4</sup>	64.1 ± 10.9 <sup>4</sup>
BMI (kg/m <sup>2</sup> ) <sup>2</sup>	23.8 ± 3.3	24.1 ± 3.4	23.5 ± 3.4 <sup>4</sup>
WC (cm) <sup>2</sup>	81.7 ± 9.7	86.5 ± 9.8 <sup>4</sup>	84.2 ± 10.7 <sup>4</sup>
Systolic BP (mm Hg) <sup>2</sup>	122.7 ± 17.3	142.3 ± 24.6 <sup>4</sup>	135.6 ± 23.8 <sup>4</sup>
Diastolic BP (mm Hg) <sup>2</sup>	75.5 ± 11.3	81.6 ± 13.6 <sup>4</sup>	78.5 ± 13.0 <sup>4</sup>
Fasting glucose (mg/dL) <sup>2</sup>	99.9 ± 22.6	117.3 ± 43.9 <sup>4</sup>	113.8 ± 45.5 <sup>4</sup>
TCHOL (mg/dL) <sup>2</sup>	202.8 ± 38.1	215.2 ± 43.4 <sup>4</sup>	204.6 ± 45.1
Triacylglycerol (mg/dL) <sup>2</sup>	143.5 ± 122.9	164.9 ± 149.8 <sup>5</sup>	152.0 ± 144.5 <sup>6</sup>
HDL-C (mg/dL) <sup>2</sup>	43.0 ± 14.4	42.5 ± 16.9	43.4 ± 16.8
Betel nut chewing [n (%)] <sup>7</sup>			
Never			
Former	43 345 (79.4)	246 (79.6)	1220 (78.8)
Current	5402 (9.9)	31 (10.0)	166 (10.7)
Smoking [n (%)] <sup>7</sup>	5820 (10.7)	32 (10.4)	163 (10.5)
Never			
Former	25 275 (47.6)	112 (37.7) <sup>4</sup>	547 (36.4) <sup>4</sup>
Current	6356 (12.0)	64 (21.5)	288 (19.2)
	21 512 (40.5)	121 (40.7)	667 (44.4)

<sup>1</sup> WC, waist circumference; BP, blood pressure; TCHOL, total cholesterol; HDL-C, HDL cholesterol; CVD, cardiovascular disease. Statistical analysis was performed to compare variables between survivors and CVD deaths and between survivors and all-cause deaths.

<sup>2</sup> Student's *t* test was used to compare continuous variables.

<sup>3</sup>  $\bar{x} \pm SD$  (all such values).

<sup>4</sup> *P* < 0.001.

<sup>5</sup> *P* < 0.01.

<sup>6</sup> *P* < 0.05.

<sup>7</sup> Pearson's chi-square test was used to compare categorical data.

no use of betel nuts, respectively, at baseline survey. Furthermore, current betel nut chewers were divided into 2 groups according to the frequency of use: those who reported chewing betel nut 1–6 times/wk and those who reported chewing it  $\geq 7$  times/wk. Current, former, and never smokers were defined as those who reported current use, prior use, and no use of cigarette smoking, respectively. Current, former, and never drinkers of alcohol were defined as those who reported current use, prior use, and no use of alcohol, respectively. Physical activity was divided into 3 levels: none to mild (exercised <1 h/wk), moderate (exercised 1–4 h/wk), and vigorous (exercised >5 h/wk) physical

activity. Income was divided into 3 levels: low (<\$12 500/y; US\$1 = 32 New Taiwan dollars), middle (\$12 500–\$37 500/y), and high (>\$37 500/y). Education was also divided into 3 levels: low (elementary school and below), middle (junior and senior high school), and high (college or university and above).

#### Statistical analysis

The data are presented as the means and SDs for continuous variables. The Kolmogorov-Smirnov test was assessed before further analyses, and log transformation was used for variables with significant deviation from normal distribution. Student's *t*

**TABLE 3**

Relative risks (and 95% CIs) of betel nut chewing for cardiovascular disease (CVD) and all-cause mortality in several different models using Cox proportional hazards regression analyses adjusted for some potential confounders

Betel nut chewing	Mortality	Model 1 <sup>1</sup>	Model 2 <sup>2</sup>	Model 3 <sup>3</sup>
Never	CVD	1.00 (reference)	1.00 (reference)	1.00 (reference)
Former	CVD	1.79 (1.23, 2.62) <sup>4</sup>	1.62 (1.06, 2.47) <sup>5</sup>	1.56 (1.02, 2.38) <sup>5</sup>
Current	CVD	2.02 (1.39, 2.95) <sup>6</sup>	2.01 (1.30, 3.10) <sup>4</sup>	2.02 (1.31, 3.13) <sup>4</sup>
Never	All-cause	1.00 (reference)	1.00 (reference)	1.00 (reference)
Former	All-cause	1.78 (1.51, 2.10) <sup>6</sup>	1.22 (1.30, 1.75) <sup>6</sup>	1.40 (1.17, 1.68) <sup>6</sup>
Current	All-cause	1.85 (1.57, 2.19) <sup>6</sup>	1.21 (1.28, 1.78) <sup>6</sup>	1.40 (1.16, 1.70) <sup>4</sup>

<sup>1</sup> Adjusted for age and BMI.

<sup>2</sup> Adjusted for age, BMI, alcohol consumption, smoking, physical activity status, income, and education level.

<sup>3</sup> Adjusted for age, BMI, diabetes, hypertension, total cholesterol, HDL cholesterol, triacylglycerol, alcohol consumption, smoking, physical activity status, income, and education level.

<sup>4</sup> *P* < 0.01.

<sup>5</sup> *P* < 0.05.

<sup>6</sup> *P* < 0.001.

1046  
b

test for unpaired data was used to compare mean values between 2 groups. Proportions and categorical variables were tested by the chi-square test and by the 2-tailed Fisher's exact method when appropriate. Cox proportional hazards regression analyses adjusted for possible confounders were used to estimate the relative risks (RRs) for CVD and all-cause mortality. Survival curves adjusted for other covariates were drawn for current and never betel nut chewers, never smokers, and never betel nut chewers, respectively (21, 22). These statistical analyses were performed by using SPSS statistical software (version 13.0; SPSS Inc, Chicago, IL).

**RESULTS**

There were 1549 deaths over 8 y of follow-up; of these deaths, 309 were due to CVD. At the baseline survey, there were 44 565 (79.4%) never chewers, 5568 (9.9%) former chewers, and 5983 (10.7%) current betel nut chewers. The current betel nut chewers were younger and had higher BMI, waist circumference, and triacylglycerol than did never chewers, as is shown in Table 1. There was a higher proportion of smoking and alcohol consumption among current and former betel nut chewers than among never chewers. As shown in Table 2, participants who died of CVD were older and had greater waist circumference, higher systolic and diastolic BP, and fasting glucose, total cholesterol, and triacylglycerol concentrations than did survivors. Participants who died of any cause also were older and had greater waist circumference, higher systolic and diastolic BP, and higher fasting glucose and triacylglycerol concentrations than did survivors.

Using Cox proportional hazards regression analyses with adjustment for potential confounders, the RRs for CVD and all-cause mortality were higher among current and former betel nut chewers than among never chewers (Table 3). Among the 3 models, there was no interaction ( $P > 0.05$ ) between betel nut chewing and smoking status for predicting the risk of CVD and all-cause mortality. The adjusted RRs for CVD and all-cause mortality were 1.56 (95% CI: 1.02, 2.38) and 1.40 (1.17, 1.68) in former users and 2.02 (1.31, 3.13) and 1.40 (1.16, 1.70) in current users, respectively (model 3 in Table 3).

Among the current and never chewers, increased frequency of betel nut chewing was associated with greater CVD and all-cause mortality. The adjusted RRs for CVD and all-cause mortality were higher among those who currently chewed betel nut  $\geq 7$  times/wk than among those who currently chewed betel nut  $< 7$  times/wk and the never chewers (Figure 1). The adjusted RRs for CVD and all-cause mortality among the current chewers who chewed  $\geq 7$  times/wk were 2.37 (1.07, 5.23) and 2.18 (1.53, 3.10), respectively, compared with those who chewed  $< 7$  times/wk. Similarly, among the never smokers, the adjusted RRs for CVD and all-cause mortality were also higher among those who currently chewed betel nut  $\geq 7$  times/wk than among those who currently chewed betel nut  $< 7$  times/wk and never chewers (Figure 2). Among the never chewers, the adjusted RRs for CVD and all-cause mortality in the current smokers were higher than that among the never smokers (Figure 3).

The adjusted RRs for CVD and all-cause mortality among various combinations of smoking and betel nut chewing status are shown in Table 4. Current and former betel nut chewers had higher risks of CVD (RR: 2.10;  $P = 0.05$ ) and all-cause (RR: 1.19;  $P = 0.354$ ) mortality than did current and former smokers.

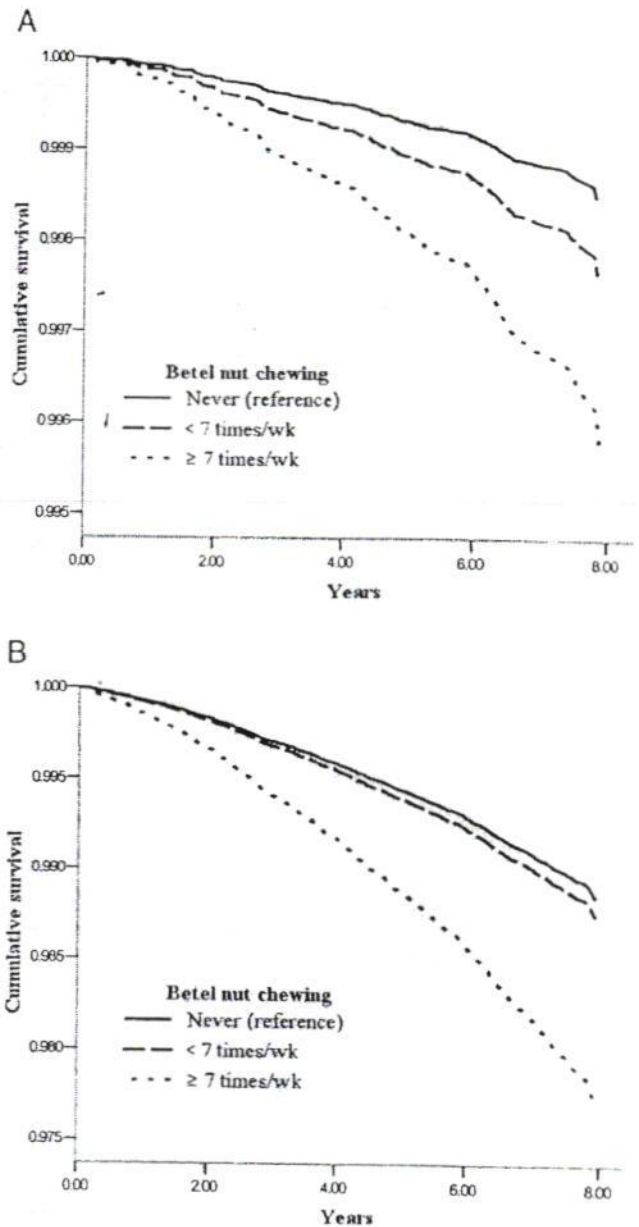

**FIGURE 1.** Survival curves for current and never chewers ( $n = 50\ 548$ ) after adjustment for other covariates. Cox proportional hazards regression analyses were adjusted for age, BMI, diabetes, hypertension, total cholesterol, HDL cholesterol, triacylglycerol, alcohol consumption, smoking, physical activity status, income, and education level. A: The adjusted relative risk (RR) (and 95% CIs) for CVD mortality among subjects who currently chewed betel nut  $\geq 7$  times/wk and  $< 7$  times/wk was 2.77 (1.58, 4.88) and 1.55 (0.86, 2.80), respectively, compared with those who never chewed. B: The adjusted RR for all-cause mortality among subjects who currently chewed betel nut  $\geq 7$  times/wk and  $< 7$  times/wk was 2.02 (1.57, 2.60) and 1.09 (0.84, 1.42), respectively, compared with those who never chewed.

**DISCUSSION**

In this population-based prospective study, we showed that betel nut chewing was associated with greater CVD and all-cause mortality in Taiwanese men. Similarly, Lan et al (4) showed that areca nut chewing is associated with greater CVD and all-cause mortality in the Taiwanese elderly. In addition, we also found



1647  
f

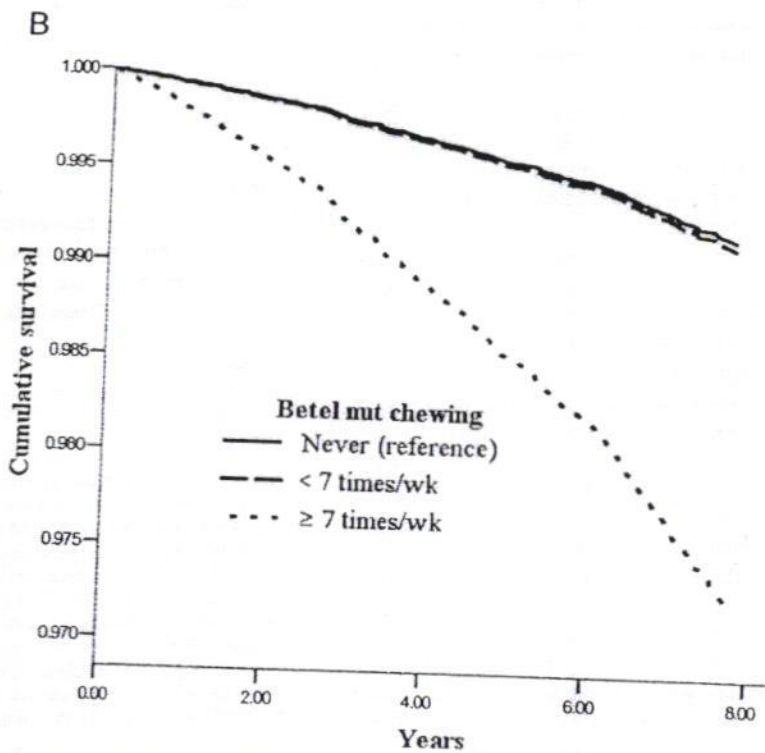
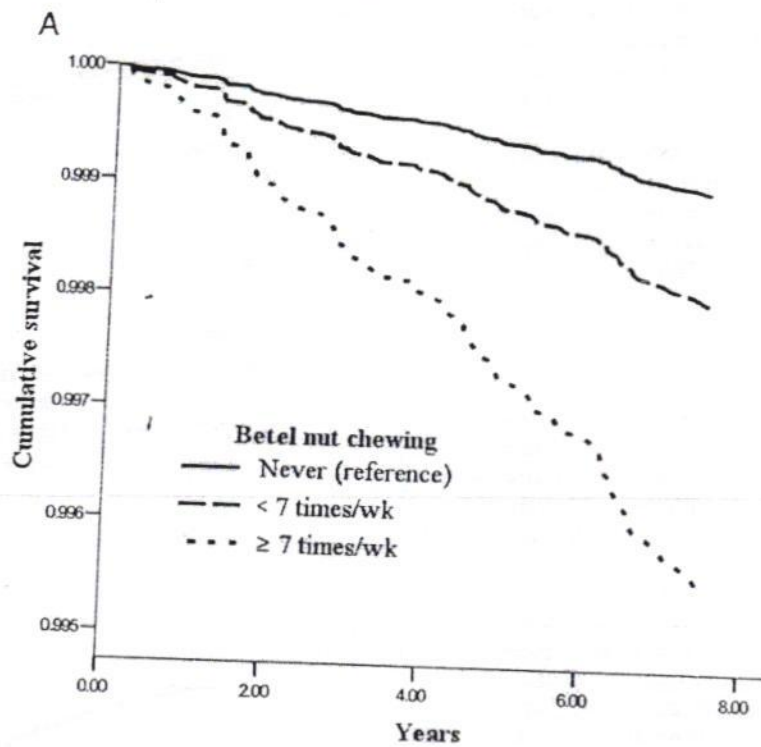

**FIGURE 2.** Survival curves for never smokers ( $n = 25\,822$ ) after adjustment for other covariates. Cox proportional hazards regression analyses were adjusted for age, BMI, diabetes, hypertension, total cholesterol, HDL cholesterol, triacylglycerol, alcohol consumption, physical activity status, income, and education level. A: The adjusted relative risk (RR) (and 95% CIs) for CVD mortality among subjects who currently chewed betel nut  $\geq 7$  times/wk and  $< 7$  times/wk was 4.49 (1.04, 19.5) and 1.98 (0.47, 8.36), respectively, compared with those who never chewed. B: The adjusted RR for all-cause mortality among subjects who currently chewed betel nut  $\geq 7$  times/wk and  $< 7$  times/wk was 3.34 (1.63, 6.84) and 1.05 (0.46, 2.38), respectively, compared with those who never chewed.

148  
f



Downloaded from www.ajcn.org at University of Toronto on January 25, 2011

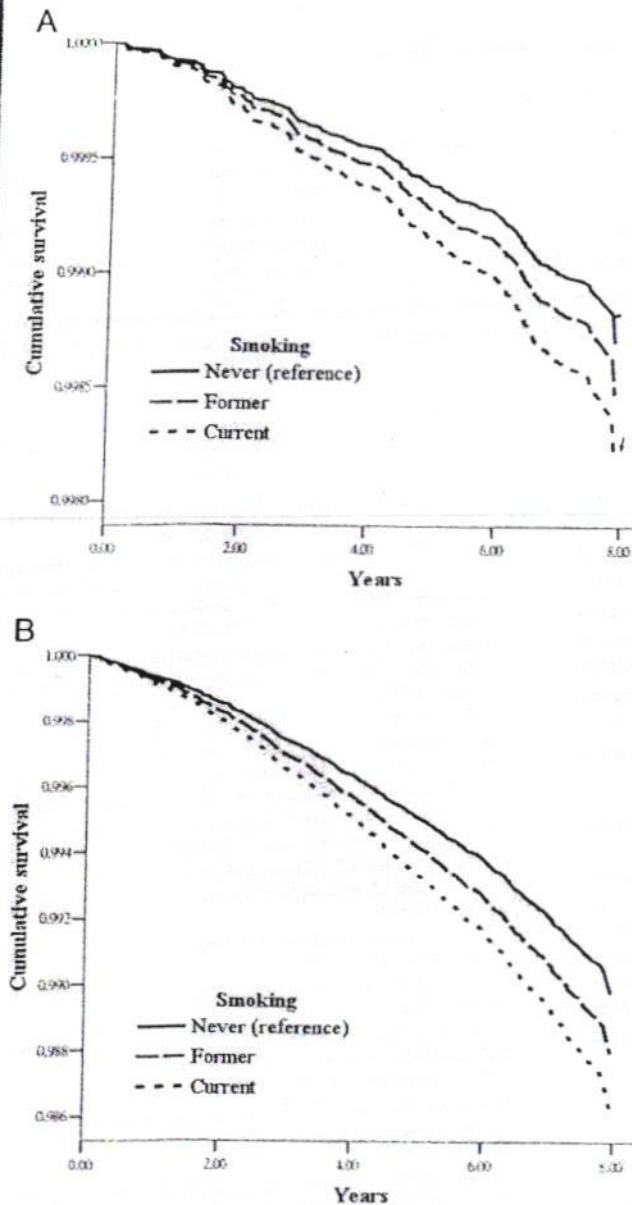

FIGURE 3. Survival curves for never chewers of betel nut ( $n = 44\ 565$ ) after adjustment for other covariates. Cox proportional hazards regression analyses were adjusted for age, BMI, diabetes, hypertension, total cholesterol, HDL cholesterol, triacylglycerol, alcohol consumption, physical activity status, income, and education level. A: The adjusted relative risk (RR) (and 95% CIs) for CVD mortality among subjects who were current and former smokers was 1.39 (1.01, 1.91) and 1.17 (0.82, 1.68), respectively, compared with those who never smoked. B: The adjusted RR for all-cause mortality among subjects who were current and former smokers was 1.35 (1.17, 1.56) and 1.18 (1.00, 1.39), respectively, compared with those who never smoked.

that the RRs for CVD and all-cause mortality increased with the frequency of betel nut chewing. Furthermore, betel nut chewing was associated with a higher risk of CVD and all-cause mortality than was smoking. Betel nut chewing, therefore, has become a big challenge to public health in Taiwan as well as in other areas with high prevalence of betel nut chewing.

Although most of the world's betel nut chewers are in Asia (2), the growing number of immigrants from Asia to Europe and

North America means that betel nut chewing is becoming a global problem. The number of betel nut chewers has been estimated at up to 600 million worldwide (3). Previous studies have clearly shown arecal alkaloids to be carcinogens, which increase the risk of various cancers of the oral cavity, esophagus, and liver (3, 8, 9, 23, 24). In addition, betel nut chewing has been found to be associated with obesity, metabolic syndrome, diabetes, and chronic kidney disease (13, 14, 16, 25). Although these diseases are closely related to the development of CVD, the relation between betel nut chewing and CVD remains unclear.

In the present study, we found that current and former betel nut chewers had greater CVD mortality than did never chewers. Furthermore, betel nut chewing and smoking were independently associated with CVD mortality. We also found that current and former betel nut chewers had a higher risk of CVD mortality (RR: 2.10;  $P < 0.05$ ) than did current and former smokers. Moreover, the RRs for CVD and all-cause mortality increased with the frequency of betel nut chewing. Therefore, betel nut chewing should be treated as a major risk factor for CVD. Developing a cessation program should be considered as an intervention strategy for CVD among betel nut chewers.

Several possible mechanisms may explain the relation between betel nut chewing and greater CVD mortality. First, betel nut chewing appears to activate the sympathetic nervous system, thereby inducing the secretion of adrenal catecholamines (1, 26). Second, arecal alkaloids act as inhibitors of  $\gamma$ -aminobutyric acid receptor. The blockade of the inhibitory effects of  $\gamma$ -aminobutyric acid on glucagon and somatotrophin may result in the secretion of glucagon and subsequently in the development of diabetes. Greater appetite and glucose intolerance due to  $\gamma$ -aminobutyric acid inhibition and diabetogenic arecal nitrosamines may also play an important role in the development of diabetes (1, 11, 13, 14, 25, 27, 28). Third, betel nut chewing enhances oxidative stress, which increases the risk of CVD (29, 30). Fourth, betel nut chewing may induce periodontal disease, which is a chronic inflammatory disease with T cell activation and production of inflammatory mediators (31). Among these factors, interleukin-6 and tumor necrosis factor- $\alpha$  are proinflammatory cytokines related to the development of CVD (32–34). It is interesting that, in a meta-analysis of 9 cohort studies, Janket et al (35) showed that persons with periodontal disease have a greater incidence of CVD than do those without periodontal disease. Therefore, the complex pathogenesis of CVD related to betel nut chewing deserves further study.

Although we have shown that betel nut chewing is associated with a greater risk of CVD and all-cause mortality, the present study has some limitations. First, the questionnaires were lacking in details about betel use, such as the numbers of quids used per day, the duration of the habit, and the preparation used. Therefore, the exact duration and cumulative exposure of betel nut could not be quantified in the present study. Similar limitations were noted for smoking status. Second, our study population was drawn from generally healthy volunteers who attended health screening centers rather than from nationally representative subjects. External validation is necessary in future studies. Third, the fact that only baseline data for these participants were available may have led to possible misclassifications of betel nut chewing status during follow-up.

1049  
R

TABLE 4

Relative risks (and 95% CIs) among the various combinations of smoking and betel nut chewing status for cardiovascular disease (CVD) and all-cause mortality using Cox proportional hazards regression analyses<sup>1</sup>

	CVD	All-cause
Never smoking and never betel nut chewing ( $n = 24\ 682$ )	1.00 (Reference)	1.00 (Reference)
Former smoking and never betel nut chewing ( $n = 5204$ )	1.17 (0.81, 1.67)	1.17 (0.99, 1.38)
Current smoking and never betel nut chewing ( $n = 13\ 626$ )	1.27 (0.92, 1.74)	1.30 (1.13, 1.49) <sup>2</sup>
Current or former betel nut chewing and never smoking ( $n = 1140$ )	2.91 (1.43, 5.93) <sup>1</sup>	1.61 (1.11, 2.34) <sup>1</sup>
Current or former betel nut chewing and current or former smoking ( $n = 9993$ )	2.03 (1.38, 3.00) <sup>2</sup>	1.80 (1.52, 2.12) <sup>2</sup>

<sup>1</sup> Model adjusted for age, BMI, diabetes, hypertension, total cholesterol, HDL cholesterol, triacylglycerol, alcohol consumption, physical activity status, income, and education level. There was no interaction between betel nut chewing and smoking status for predicting the risk of CVD ( $P = 0.192$ ) or all-cause mortality ( $P = 0.087$ ).

<sup>2</sup>  $P < 0.001$ .

<sup>3</sup>  $P < 0.01$ .

<sup>4</sup>  $P < 0.05$ .

In conclusion, we have shown betel nut chewing to be independently associated with greater CVD and all-cause mortality after control for possible confounders in Taiwanese men. The RRs for CVD and all-cause mortality increased with the frequency of betel nut chewing. Furthermore, betel nut chewing had a greater risk of CVD mortality than did smoking. At the national level, it is crucial to develop a special program to help betel nut chewers quit their habit. For physicians and other health workers, it is important to screen people for betel nut chewing in their clinical practices. Furthermore, the detailed relation between betel nut chewing and CVD requires further investigation.

We thank T-C Lee (Graduate Institute of Chinese Medicine Science, China Medical University) for her help with respect to statistics.

The authors' responsibilities were as follows—W-YL: the study design, data analysis, and writing of the manuscript draft; T-YC: participated in the data collection and study design; L-TL and C-CL: assisted in data management and interpretation of results; C-YH: contributed to the concepts investigated and statistical analyses; K-CH: synthesized the analyses and was responsible for the writing of the manuscript; and all authors: approved the final manuscript. None of the authors had a personal or financial conflict of interest.

## REFERENCES

- Boucher BJ, Mannan N. Metabolic effects of the consumption of *Areca catechu*. *Addict Biol* 2002;7:103-10.
- Gupta PC, Warnakulasuriya S. Global epidemiology of areca nut usage. *Addict Biol* 2002;7:77-83.
- IARC Working Group on the Evaluation of Carcinogenic Risks to Humans. Betel-quid and areca-nut chewing and some areca-nut derived nitrosamines. *IARC Monogr Eval Carcinog Risks Hum* 2004;85:1-334.
- Lan TY, Chang WC, Tsai YJ, Chuang YL, Lin HS, Tai TY. Areca nut chewing and mortality in an elderly cohort study. *Am J Epidemiol* 2007;165:677-83.
- Wollina U, Verma S, Parikh D, Parikh A. [Oral and extraoral disease due to betel nut chewing]. *Hautarzt* 2002;53:795-7 (in German).
- Zhang X, Reichart PA. A review of betel quid chewing, oral cancer and precancer in Mainland China. *Oral Oncol* 2007;43:424-30.
- Sciubba JJ. Oral cancer. The importance of early diagnosis and treatment. *Am J Clin Dermatol* 2001;2:239-51.
- Tsai JF, Jeng JE, Chuang LY. Habitual betel quid chewing and risk for hepatocellular carcinoma complicating cirrhosis. *Medicine* 2004;83:176-87.
- Wu IC, Lu CY, Kuo FC, et al. Interaction between cigarette, alcohol and betel nut use on esophageal cancer risk in Taiwan. *Eur J Clin Invest* 2006;36:236-41.
- Hsiao TJ, Liao HW, Hsieh PS, Wong RH. Risk of betel quid chewing on the development of liver cirrhosis: a community-based case-control study. *Ann Epidemiol* 2007;17:479-85.
- Yen AM, Chiu YH, Chen LS, et al. A population-based study of the association between betel-quid chewing and the metabolic syndrome in men. *Am J Clin Nutr* 2006;83:1153-60.
- Chung FM, Chang DM, Chen MP, et al. Areca nut chewing is associated with metabolic syndrome: role of tumor necrosis factor- $\alpha$ , leptin, and white blood cell count in betel nut chewing-related metabolic derangements. *Diabetes Care* 2006;29:1714.
- Chang WC, Hsiao CF, Chang HY, et al. Betel nut chewing and other risk factors associated with obesity among Taiwanese male adults. *Int J Obes (Lond)* 2006;30:359-63.
- Tung TH, Chiu YH, Chen LS, Wu HM, Boucher BJ, Chen TH. A population-based study of the association between areca nut chewing and type 2 diabetes mellitus in men (Keelung Community-based Integrated Screening Programme no. 2). *Diabetologia* 2004;47:1776-81.
- Guh JY, Chen HC, Tsai JF, Chung LY. Betel-quid use is associated with heart disease in women. *Am J Clin Nutr* 2007;85:1229-35.
- Kang IM, Chou CY, Tseng YH, et al. Association between betel nut chewing and chronic kidney disease in adults. *J Occup Environ Med* 2007;49:776-9.
- Thom TJ. International mortality from heart disease: rates and trends. *Int J Epidemiol* 1989;18:S20-8.
- Taiwan Public Health Report 1998-2000. Taipei, Taiwan: Department of Health, 2001.
- Lakka HM, Laaksonen DE, Lakka TA, et al. The metabolic syndrome and total and cardiovascular disease mortality in middle-aged men. *JAMA* 2002;288:2709-16.
- Huang KC, Lin WY, Lee LT, et al. Four anthropometric indices and cardiovascular risk factors in Taiwan. *Int J Obes Relat Metab Disord* 2002;26:1060-8.
- Lee ET, Go OT. Survival analysis in public health research. *Annu Rev Public Health* 1997;18:105-34.
- Ghali WA, Quan H, Brant R, et al. Comparison of 2 methods for calculating adjusted survival curves from proportional hazards models. *JAMA* 2001;286:1494-7.
- Ko YC, Huang YL, Lee CH, Chen MJ, Lin LM, Tsai CC. Betel quid chewing, cigarette smoking and alcohol consumption related to oral cancer in Taiwan. *J Oral Pathol Med* 1995;24:450-3.
- Thomas SJ, Bain CJ, Battistutta D, Ness AR, Paissat D, MacLennan R. Betel quid not containing tobacco and oral cancer: a report on a case-control study in Papua New Guinea and a meta-analysis of current evidence. *Int J Cancer* 2007;120:1318-23.
- Guh JY, Chuang LY, Chen HC. Betel-quid use is associated with the risk of the metabolic syndrome in adults. *Am J Clin Nutr* 2006;83:1313-20.
- Chu NS. Neurological aspects of areca and betel chewing. *Addict Biol* 2002;7:111-4.
- Okamoto H. [Molecular mechanism of degeneration, oncogenesis and regeneration of pancreatic beta-cells of islets of Langerhans]. *Nippon Naika Gakkai Zasshi* 1988;77:1147-56 (in Japanese).
- Okamoto H. Degeneration, oncogenesis and regeneration of pancreatic beta-cells of islets of Langerhans. *Nippon Naibunpi Gakkai Zasshi* 1988;64:1236-7.
- Lai KC, Lee TC. Genetic damage in cultured human keratinocytes stressed by long-term exposure to areca nut extracts. *Mutat Res* 2006;599:66-75.



30. Molavi B, Mehta JL. Oxidative stress in cardiovascular disease: molecular basis of its deleterious effects, its detection, and therapeutic considerations. *Curr Opin Cardiol* 2004;19:488-93.
31. Jeng JH, Wang YJ, Chiang BL, et al. Roles of keratinocyte inflammation in oral cancer: regulating the prostaglandin E2, interleukin-6 and TNF-alpha production of oral epithelial cells by areca nut extract and arecoline. *Carcinogenesis* 2003;24:1301-15.
32. Mellick GD. TNF gene polymorphism and quantitative traits related to cardiovascular disease: getting to the heart of the matter. *Eur J Hum Genet* 2007;15:609-11.
33. Gallucci M, Amici GP, Ongaro F, et al. Associations of the plasma interleukin 6 (IL-6) levels with disability and mortality in the elderly in the Treviso Longeva (Trelong) study. *Arch Gerontol Geriatr* 2007;44(suppl):193-8.
34. Liu Y, Berthier-Schaad Y, Fallin MD, et al. IL-6 haplotypes, inflammation, and risk for cardiovascular disease in a multiethnic dialysis cohort. *J Am Soc Nephrol* 2006;17:863-70.
35. Janket SJ, Baird AE, Chuang SK, Jones JA. Meta-analysis of periodontal disease and risk of coronary heart disease and stroke. *Oral Surg Oral Med Oral Pathol Oral Radiol Endod* 2003;95:559-69.

1051  
R

1	
---	--

*J Clin Periodontol.* 2008 Jan;35(1):9-15. Epub 2007 Nov 15.

## Relationship between betel quid additives and established periodontitis among Bangladeshi subjects.

Akhter R, Hassan NM, Aida J, Takinami S, Morita M.

Department of Preventive Dentistry, Okayama University Dental School, Okayama, Japan.

### Abstract

**AIM:** To determine the relationship between betel quid chewing additives and established periodontitis in Bangladeshi subjects.

**MATERIAL AND METHODS:** A total of 864 subjects participated in this study. Among them, 140 pairs of sex- and age-matched case subjects and control subjects were selected. A case was defined as a person who had at least two sites with a clinical attachment level (CAL)  $\geq$  6 mm and at least one site with probing depth (PD)  $\geq$  5 mm. Subjects who did not fulfill these criteria were considered as controls. Information on sociodemographic variables, psychological stress, dental health behaviour, smoking and betel quid chewing habits was obtained.

**RESULTS:** Multiple logistic regression analysis showed that current betel quid chewers had greater probabilities of having established periodontal disease than did non-chewers (odds ratio=3.97,  $p < 0.05$ ). Mean PD, mean CAL, mean percentage of bleeding on probing and number of missing teeth were significantly higher in chewers of betel quid with tobacco and masala than in chewers of betel quid without such additives adjusting for age, sex, smoking habit, body mass index, dental visit pattern, stress and plaque index. Higher frequency and longer duration of betel quid chewing showed a significant relation to an increase in periodontal parameters.

**CONCLUSION:** The results indicate that betel quid additives might significantly enhance periodontitis in the population studied.

PMID: 18021263 [PubMed - indexed for MEDLINE]

1052  
B

Annals 145

# Dental Caries and Periodontitis Associated with Betel Quid Chewing: Analysis of Two Data Sets

Supaporn Chatrchaiwiwatana DDS, MPH, DrPH\*

\* Faculty of Dentistry, Khon Kaen University, Khon Kaen

**Background:** Not much research evidence concerning the relationship between betel quid chewing and oral health has been established although betel quid chewing is a common practice among people in many Asian countries including rural areas of Thailand.

**Objective:** The present study employed two existing data sets to evaluate the association between betel quid chewing and oral diseases.

**Material and Method:** The study populations for phase I comprised a total of 796 females, aged 30-89 years, residing in five districts of Khon Kaen province, Thailand during 1990-91. In phase II, there were 2,253 females, aged 31-86 years, residing in Chonnabot district, Khon Kaen province, Thailand during 1992-94, respectively. The data were obtained through oral examination and interview. The analyses employed descriptive, bivariate, and multivariable logistic regression.

**Results:** Findings from final multivariable logistic regression models revealed the inverse relationship between betel quid chewing and dental caries adjusting for other variables. In addition, results from the final multivariable logistic regression models predicting periodontitis showed that betel quid chewing was directly associated with periodontitis in the presence of several confounding factors. The consistent findings from both data sets suggest that although betel quid chewing may reduce dental caries, it was directly related to periodontitis and enhanced the possibility of increasing tooth loss.

**Conclusion:** Therefore, preventive programs aiming at discouraging Thai people from chewing betel quid should be established to preserve favorable oral health.

**Keywords:** Betel quid chewing, Dental caries, Periodontitis, Tooth loss, Thailand

*J Med Assoc Thai* 2006; 89 (7): 1004-11

Full text. e-Journal: <http://www.medassochai.org/journal>

Betel quid chewing has been practiced among people in many Asian countries including rural areas of Thailand for quite a long time and research evidence on the effects of betel quid chewing towards oral cancer and oral soft tissue lesions is ample<sup>(1-10)</sup>. However, only a limited number of studies have investigated the relationship between betel quid chewing and oral diseases namely dental caries and periodontitis, particularly among Thai people<sup>(11-18)</sup>. In order to maintain effectively favorable oral health, the evidence of oral diseases associated with betel quid chewing among Thai people should be investigated. Therefore, the ob-

jective of the present study was set to evaluate the association between betel quid chewing and oral diseases including dental caries and periodontitis among rural Thai females using two existing data sets.

## Material and Method

### I. Power and sample size determination

For both data sets, the required sample size for studying the relationship between dental caries and betel quid chewing as well as between periodontitis and betel quid chewing was calculated based on the test for difference between proportions. The 10-20% of the required sample size was added to account for the nature of study as multivariable type. The sample size was estimated based on the following information: 1) Proportion of betel quid users having dental caries (or

Correspondence to : Chatrchaiwiwatana S, Faculty of Dentistry, Khon Kaen University, Khon Kaen 40002, Thailand. Phone: 043-202-405. Fax: 043-202-862. E-mail: csupa@kku.ac.th, csupaporn2001@yahoo.com

1053

periodontitis), 2) Proportion of non-betel quid users having dental caries (or periodontitis), 3) Alpha level = 0.05; two-tailed test;  $Z_{1-\alpha/2} = 1.96$ , 4). Power of the study = 0.80;  $Z_{1-\beta} = 0.84$ .

For data set I (phase I study), the calculations yielded a required sample size for studying the association between betel quid chewing and dental caries of 372 subjects, and between betel quid chewing and periodontitis of 410 subjects. Therefore the sample size of 796 females was adequate for controlling simultaneous effects of more than five major confounding factors in the final multivariable model<sup>(19,20)</sup>.

Likewise, for phase II, the calculations yielded a required sample size for studying the association between betel quid chewing and dental caries of 364 subjects, and between betel quid chewing and periodontitis of 424 subjects. Therefore, the sample size of 2,253 females was adequate for simultaneously assessing effects of more than 10 major confounding factors in the final multivariable model<sup>(19,20)</sup>.

## II. Study population

The data used in the present study were taken from the Mobile Screening Clinic for Leading Cancers in Khon Kaen province, Thailand, phase I and phase II. The study population in phase I comprised a total of 796 female adults, aged 30-89 years, residing in five districts of Khon Kaen province, Thailand during 1990-91. Phase II included 2,253 females, aged 31-86 years, residing in Chonnabot district of Khon Kaen province, Thailand during 1992-1994. All the study populations participated in the screening program and had completed both the oral examination and the interview. The present study was approved by Khon Kaen University Ethics Committee for Human Research.

## III. Oral examination

All the oral examinations were conducted at the village centers, using mainly a mobile dental chair, a sterilized mouth mirror, a sterilized no. 3 explorer and a sterilized WHO periodontal probe. The examinations were carried out under natural light. Trained licensed dentists from the Department of Community Dentistry, Faculty of Dentistry, Khon Kaen University conducted the examinations. Before conducting oral examinations in the study villages, all the examiners participated in an extensive calibration session, where the activities involved reviewing the examination criteria, applying the criteria in ten people, and discussing any discrepancies regarding the examination criteria to reach consistent clinical judgments. According to the time

constraints, only the simple and easy-to-perform examination indexes and criteria were selected for use in the oral examinations.

Data concerning clinical oral examination included dental caries status, debris index and periodontal status, where the indexes and criteria were previously described<sup>(18)</sup>.

## IV. Interview

Trained nurses from the Cancer Unit, Faculty of Medicine conducted the interview. The information on sociodemographic and lifestyle characteristics was gathered. Sociodemographic factors included age, education level, monthly income (baht), occupational status and district of residence. Information regarding lifestyle characteristics covered betel quid chewing, tobacco smoking, alcohol consumption, and tooth brushing (only in phase I).

## V. Data management and data analysis

The data were first recorded on-site by a well-trained dental assistant, then were entered into the computing database at the Cancer Unit, Faculty of Medicine, Khon Kaen University, and were verified at the Department of Community Dentistry, Faculty of Dentistry, Khon Kaen University. The data were analyzed using SAS version 8.0 and SPSS version 10.0. The descriptive, mean, standard deviation and bivariate using unpaired t test, chi-square test where appropriated and multivariable logistic regression with 95% confidence limit of odds ratio. A p-value of less than 0.05 was considered significant difference.

## Results

Results from the descriptive analyses in phase I showed that 52.1% of people experienced one or more teeth with decayed or filled condition, while 38.7% had either shallow or deep periodontal pockets. The proportion of betel quid users accounted for 30.5%. For phase II, 59.1% of people experienced one or more decayed or filled teeth and 39.9% had either shallow or deep periodontal pockets. The proportion of betel quid users accounted for 25.5%. This was much lower than in phase I (data not tabulated).

Findings obtained from bivariate analyses from both phases gave similar results; dental caries (defined as decayed plus filled teeth), were associated with betel quid chewing, missing teeth and periodontitis. Age, tooth brushing, and mild debris deposit (debris deposit less than 1/3 of enamel crown) were related to dental caries only in phase I, while dental

1054  
Q

**Table 1.** Results from bivariate analyses between dental caries (decayed plus filled teeth) and selected variables for phase I and phase II data sets\*

Variable	p-value	
	Phase I (N = 766)	Phase II (N = 2253)
Age (mean $\pm$ SD in years)	0.0009 <sup>b</sup>	0.1087
Monthly income (mean $\pm$ SD in baht)	0.8741	0.9831
Marital status (married vs single)	0.092	0.579
Education (none / primary school / beyond primary school)	0.440	0.555
Betel quid chewing (no vs yes)	0.001 <sup>c</sup>	0.001 <sup>c</sup>
Tobacco smoking (no vs yes)	0.917	0.958
Alcohol use (no vs yes)	0.628	0.116
Tooth brushing (no vs yes)	0.001 <sup>c</sup>	na <sup>d</sup>
Missing teeth (no vs yes)	0.001 <sup>c</sup>	0.001 <sup>c</sup>
Periodontitis (no vs yes)	0.001 <sup>c</sup>	0.001 <sup>c</sup>
Debris deposits (mean $\pm$ SD in sextants)		
Mild (< 1/3 of enamel)	0.0145 <sup>b</sup>	0.2046
Moderate (1/3-2/3 of enamel)	0.2530	0.5678
Heavy (> 2/3 of enamel)	0.8796	0.9390
Periodontal status (mean $\pm$ SD in sextants)		
Gingival bleeding	0.4522	0.5244
Dental calculus	0.0883	0.0253 <sup>b</sup>
Shallow periodontal pocket	0.9476	0.0006 <sup>b</sup>
Deep periodontal pocket	0.4880	0.8861

\* Total sample may not add up to 100 per cent due to incomplete data for some variables

<sup>b</sup> Test of difference between means (*t*-test),  $p < 0.05$

<sup>c</sup> Test of difference between proportion (Chi-square test),  $p < 0.05$

<sup>d</sup> na: not available

calculus, and shallow periodontal pockets were connected to dental caries only in phase II (Table 1).

Bivariate relationship between periodontitis and selected variables showed a significant relationship of periodontitis with age, betel quid chewing, and missing teeth for both phases. However, sociodemographic variables including marital status and education were related to periodontitis only in phase I. Likewise, tooth brushing, mild, moderate, and heavy debris deposits (debris deposit less than 1/3, 1/3-2/3, and greater than 2/3 of enamel crown, respectively) were significant in phase I only while income and dental caries were associated with periodontitis in phase II only (Table 2).

Variables demonstrating statistical significance with dental caries and periodontitis in bivariate analyses were entered into multivariable logistic regression models predicting dental caries and periodontitis for both phases and the findings were consistent for both data sets. From Table 3, after adjusting for potential confounding factors in the final multivariable logistic regression models, betel quid chewing

and missing teeth consistently retained predicting dental caries in both data sets. Mild debris deposit was marginally significant in phase I only and periodontal pocket retained in the final multivariable logistic regression model as a predictor of dental caries solely in phase II. From both data sets, betel quid chewing was inversely related to dental caries while all other factors were associated directly with dental caries, with the odds ratios and 95% confidence limits shown in Table 3.

Table 4 displays variables predicting periodontitis for both phases. Betel quid chewing, age, debris deposits, and missing teeth were associated directly with periodontitis, with the odds ratios and 95% confidence limits shown in the table. Decayed teeth remained in the final multivariable logistic regression model predicting periodontitis only in phase II. For analyses of the final multivariable logistic regression models predicting dental caries and periodontitis in phase I, tooth brushing was not significant. Missing data in the final multivariable logistic regression models were kept under 10% in general.

1055  
R

**Table 2.** Results from bivariate analyses between periodontitis and selected variables for phase I and phase II data sets\*

Variable	p-value	
	Phase I	Phase II
Age (mean ± SD in years)	0.0001 <sup>b</sup>	0.0001 <sup>b</sup>
Monthly income (mean ± SD in baht)	0.4842	0.0150 <sup>b</sup>
Marital status (married vs single)	0.001 <sup>c</sup>	0.526
Education (none / primary school / beyond primary school)	0.001 <sup>c</sup>	0.578
Betel quid chewing (no vs yes)	0.001 <sup>c</sup>	0.001 <sup>c</sup>
Tobacco smoking (no vs yes)	0.787	0.128
Alcohol use (no vs yes)	0.731	0.326
Tooth brushing (no vs yes)	0.001 <sup>c</sup>	na
Missing teeth (no vs yes)	0.001 <sup>c</sup>	0.001 <sup>c</sup>
Dental caries (no vs yes)	0.613	0.001 <sup>c</sup>
Debris deposits (mean ± SD in sextants)		
Mild (< 1/3 of enamel)	0.0002 <sup>b</sup>	0.2046
Moderate (1/3-2/3 of enamel)	0.0011 <sup>b</sup>	0.5678
Heavy (> 2/3 of enamel)	0.0001 <sup>b</sup>	0.9390
Decayed, Missing, and Filled Teeth (mean ± SD of teeth affected)		
Decayed teeth	0.2420	0.5244
Missing teeth	0.0001 <sup>b</sup>	0.0253 <sup>b</sup>
Filled teeth	0.6709	0.0006 <sup>b</sup>

\* Total sample may not add up to 100 per cent due to incomplete data for some variables

<sup>b</sup> Test of difference between means (*t*-test), *p* < 0.05

<sup>c</sup> Test of difference between proportion (Chi-square test), *p* < 0.05

**Table 3.** Conditional odds ratio and 95%CI of variables predicting dental caries in the final multivariable logistic regression models for phase I and phase II data sets\*

Variable	Phase I study <sup>b</sup>		
	Odds ratio	95% Confidence limit	
		Lower	Upper
Betel quid chewing	0.339	0.240	0.479
Mild debris deposit	1.005	1.000	1.010
Missing teeth	2.754	2.001	3.790

Variable	Phase II study <sup>b</sup>		
	Odds ratio	95% Confidence limit	
		Lower	Upper
Betel quid chewing	0.488	0.395	0.603
Periodontal pocket	1.236	1.020	1.498
Missing teeth	3.053	2.535	3.677

\* Total sample for phase I = 796 subjects, phase II = 2,253 subjects

<sup>b</sup> Missing data for phase I = 54 subjects (6.8 per cent)

<sup>c</sup> Missing data for phase II = 60 subjects (2.7 per cent)

1/56

**Table 4.** Conditional odds ratio and 95%CI of variables predicting periodontitis in the final multivariable logistic regression models for phase I and phase II data sets<sup>a</sup>

Phase I study <sup>b</sup>			
Variable	95% Confidence limit		
	Odds ratio	Lower	Upper
Betel quid chewing	12.104	1.119	130.940
Age	1.064	1.034	1.095
Mild debris deposit	1.016	1.007	1.025
Moderate debris deposit	1.026	1.018	1.034
Heavy debris deposit	1.026	1.018	1.034
Missing teeth	1.141	1.080	1.206
Interaction (betel quid chewing and age)	0.951	0.909	0.995

Phase II study <sup>c</sup>			
Variable	95% Confidence limit		
	Odds ratio	Lower	Upper
Betel quid chewing	13.361	3.538	50.454
Age	1.055	1.041	1.069
Heavy debris deposit	1.019	1.016	1.023
Decayed teeth	1.047	1.012	1.082
Missing teeth	1.034	1.013	1.056
Interaction (betel quid chewing and age)	0.953	0.931	0.976

<sup>a</sup> Total sample for phase I = 796 subjects, phase II = 2,253 subjects

<sup>b</sup> Missing data for phase I = 57 subjects (7.2 per cent)

<sup>c</sup> Missing data for phase II = 83 subjects (3.7 per cent)

The relative odds ratios having baseline odds ratio as 1, calculating from the interaction between betel quid chewing and age for both data sets are given in Table 5. It is evident that the risk of periodontitis increased among women who chewed betel quid compared to those who did not at all levels (mean + SD, mean, mean - SD of age).

#### Discussion

Conclusions from the present study were reached that betel quid chewing was inversely related to dental caries and it was directly related to periodontitis, leading to increased periodontitis and tooth loss. This result is in agreement with several studies<sup>(11-18)</sup>. The reasons that betel quid chewing diminishes dental caries are given as: 1). mechanical cleansing due to abrasive properties of betel quid chewing, 2). increased salivary buffer capacity, 3). high pH of lime in betel quid chewing neutralizes acid formation, 4). ion effect of calcium inhibits enamel dissolution, 5). betel film

covers the enamel preventing acid attack, 6). high fluoride content of betel quid and 7). anti-cariogenic effect of etheric oils present in betel quid<sup>(14)</sup>. On the other hand, the ingredients of betel quid including betel leaf, areca nut, slaked lime, and tobacco exhibit harmful effects to periodontal tissue. The possible reason that betel quid chewing damage periodontal tissue can be described as the cholinergic effect of betel quid together with calcium salt in the saliva produced hypersalivation-caused calculus deposition. The increased heavy deposition of calculus then can induce destruction of gingival tissue and periodontal membrane among habitual betel quid chewers<sup>(21,22)</sup>. Additionally, the effects of arecoline (a main alkaloid found in areca nut) inhibit cell attachment, cell spreading and cell migration, and decrease cell growth and collagen synthesis<sup>(23,24)</sup>. The finding that betel quid users experienced a higher severity of periodontitis than the non-user counterparts suggests that quitting chewing betel quid is beneficial for maintaining good oral health.

1057  
R

**Table 5.** Relative odds ratio calculating from the interaction between betel quid chewing and age in the final multivariable logistic regression models predicting periodontitis for both data sets

Phase I study*		
Variable	Relative odds ratio	
	Non-betel quid users	Betel quid users
At mean + standard deviation of age <sup>b</sup>	1.06	12.25
At mean of age <sup>b</sup>	17.59	21.24
At mean - standard deviation of age <sup>b</sup>	1.00	12.10
Phase II study*		
Variable	Relative odds ratio	
	Non-betel quid users	Betel quid users
At mean + standard deviation of age <sup>c</sup>	1.05	13.43
At mean of age <sup>c</sup>	14.13	17.29
At mean - standard deviation of age <sup>c</sup>	1.00	13.36

\* The calculations are based on the beta estimates in final multivariable logistic regression model predicting periodontitis for each data set

<sup>b</sup> Mean age = 46.1, standard deviation = 11.5 years

<sup>c</sup> Mean age = 49.6, standard deviation = 10.4 years

Although the conclusions of the present study were reached based on a large sample size available in both data sets, some limitations exist. One limitation of the present study includes the cross-sectional study design, which by itself provides no assessment of a true epidemiological cause-effect relationship. However, the causal relationships between betel quid chewing and the outcomes of interest were assumed based on previous experimental, randomized controlled trials, or observational cohort studies. Moreover, the strength of association between betel quid chewing and periodontitis should have been stronger. That the magnitude of association was underestimated was due to the effect of healthy volunteer bias occurring from the fact that people who experienced a higher severity of periodontitis tended not to participate in the present study.

#### Conclusion

The present study has made best use of existing data in establishing epidemiologic evidence relating oral diseases to betel quid chewing among rural Thai females. The findings would provide guidance for planning of preventive public health programs to reduce the habit of chewing betel quid so that healthy periodontal tissue can be maintained.

#### Acknowledgments

The author wishes to thank the Cancer Unit, Faculty of Medicine and the Community Dentistry Department, Faculty of Dentistry, Khon Kaen University, Khon Kaen, Thailand for providing the data used in this study.

#### References

1. Yang YH, Lien YC, Ho PS, Chen CH, Chang JS, Cheng TC, et al. The effects of chewing areca/betel quid with and without cigarette smoking on oral submucous fibrosis and oral mucosal lesions. *Oral Dis* 2005; 11: 88-94.
2. Lee CH, Lee JM, Wu DC, Hsu HK, Kao EL, Huang HL, et al. Independent and combined effects of alcohol intake, tobacco smoking and betel quid chewing on the risk of esophageal cancer in Taiwan. *Int J Cancer* 2005; 113: 475-82.
3. Shieh DH, Chiang LC, Lee CH, Yang YH, Shieh TY. Effects of arecoline, safrole, and nicotine on collagen phagocytosis by human buccal mucosal fibroblasts as a possible mechanism for oral submucous fibrosis in Taiwan. *J Oral Pathol Med* 2004; 33: 581-7.
4. Jacob BJ, Straif K, Thomas G, Ramadas K, Mathew

1158  
B

- B, Zhang ZF, et al. Betel quid without tobacco as a risk factor for oral precancers. *Oral Oncol* 2004; 40: 697-704.
5. Chang KC, Su JJ, Tsai ST, Shieh DB, Jin YT. Pathological features of betel quid-related oral epithelial lesions in taiwan with special emphasis on the tumor progression and human papillomavirus association. *Oncology* 2002; 63: 362-9.
  6. Shiu MN, Chen TH. Impact of betel quid, tobacco and alcohol on three-stage disease natural history of oral leukoplakia and cancer: implication for prevention of oral cancer. *Eur J Cancer Prev* 2004; 13: 39-45.
  7. Wang LY, You SL, Lu SN, Ho HC, Wu MH, Sun CA, et al. Risk of hepatocellular carcinoma and habits of alcohol drinking, betel quid chewing and cigarette smoking: a cohort of 2416 HBsAg-seropositive and 9421 HBsAg-seronegative male residents in Taiwan. *Cancer Causes Control* 2003; 14: 241-50.
  8. Reichart PA, Dietrich T, Khongkhunthian P, Srisuwan S. Decline of oropharyngeal cancer in Chiang Mai province, Thailand, between 1988 and 1999. *Oral Oncol* 2003; 39: 569-73.
  9. Chiba I. Prevention of Betel Quid Chewers' Oral Cancer in the Asian-Pacific Area. *Asian Pac J Cancer Prev* 2001; 2: 263-9.
  10. Lee CH, Ko YC, Huang HL, Chao YY, Tsai CC, Shieh TY, et al. The precancer risk of betel quid chewing, tobacco use and alcohol consumption in oral leukoplakia and oral submucous fibrosis in southern Taiwan. *Br J Cancer* 2003; 88: 366-72.
  11. Pearson N, Croucher R, Marcenes W, O'Farrell M. Dental health and treatment needs among a sample of Bangladeshi medical users aged 40 years and over living in Tower Hamlets, UK. *Int Dent J* 2001; 51: 23-9.
  12. Thomas S, Raja RV, Kutty R, Strayer MS. Pattern of caries experience among an elderly population in south India. *Int Dent J* 1994; 44: 617-22.
  13. Nigam P, Srivastava AB. Betel chewing and dental decay. *Fed Oper Dent* 1990; 1: 36-8.
  14. Moller IJ, Pindborg JJ, Effendi I. The relation between betel chewing and dental caries. *Scand J Dent Res* 1977; 85: 64-70.
  15. Schamschula RG, Adkins BL, Barnes DE, Charlton G. Betel chewing and caries experience in New Guinea. *Community Dent Oral Epidemiol* 1977; 5: 284-6.
  16. Chandra S, Desai VM. Relationship of betel chewing and dental caries. *J Indian Dent Assoc* 1970; 42: 269-76.
  17. Reichart P, Gehring F. Streptococcus mutans and caries prevalence in Lisu and Karen of northern Thailand. *J Dent Res* 1984; 63: 56-8.
  18. Chatrchaiwiwatana S. Risk indicators for missing teeth among adults in rural area of northeastern Thailand in relation to selected dental, lifestyle, and sociodemographic factors [dissertation]. Ann Arbor, MI: Univ. of Michigan; 2000.
  19. Lemeshow S, Hosmer DW, Klar J, Lwanga SK. Adequacy of sample size in health studies. New York: John Wiley & Sons; 1990: 135.
  20. Hulley SB, Cummings SR. Designing clinical research. Baltimore: Williams & Wilkins; 2000: 86-7.
  21. Reichart PA, Lenz H, Konig H, Becker J, Mohr U. The black layer on the teeth of betel chewers: a light microscopic, microradiographic and electron-microscopic study. *J Oral Pathol* 1985; 14: 466-75.
  22. Lee HT. The history, composition, chemistry & pharmacology of the betel-tobacco chew (QUID.). *Dent J Malaysia Singapore* 1973; 13: 63-9.
  23. Chang MC, Kuo MY, Hahn LJ, Hsieh CC, Lin SK, Jeng JH. Areca nut extract inhibits the growth, attachment, and matrix protein synthesis of cultured human gingival fibroblasts. *J Periodontol* 1998; 69: 1092-7.
  24. Jeng JH, Lan WH, Hahn LJ, Hsieh CC, Kuo MY. Inhibition of the migration, attachment, spreading, growth and collagen synthesis of human gingival fibroblasts by arecoline, a major areca alkaloid, in vitro. *J Oral Pathol Med* 1996; 25: 371-5.

1059

## โรคฟันผุและโรคปริทันต์อักเสบที่สัมพันธ์กับการเคี้ยวหมาก: การวิเคราะห์ข้อมูลสองชุด

สุภาภรณ์ ฉัตรชัยวิวัฒนา

การศึกษาวิจัยเกี่ยวกับความสัมพันธ์ระหว่างการเคี้ยวหมากกับสุขภาพของปากยังนับว่าขาดแคลน แม้ว่า การเคี้ยวหมากเป็นพฤติกรรมที่พบได้มากในประชากรในภูมิภาคเอเชีย รวมทั้งในแถบชนบทของประเทศไทย การศึกษา ครั้งนี้มีวัตถุประสงค์เพื่อนำข้อมูลสองชุดที่มีอยู่แล้วมาใช้ในการประเมินความสัมพันธ์ระหว่างการเคี้ยวหมากกับโรคใน ของปาก ในกลุ่มประชากรศึกษาระยะที่ 1 อันประกอบด้วยสตรีไทยอายุ 30-89 ปีที่อาศัยอยู่ในอำเภอต่าง ๆ ห้าอำเภอ ของจังหวัดขอนแก่น ในระหว่างปี พ.ศ. 2533 - พ.ศ. 2534 จำนวน 796 คน ส่วนกลุ่มประชากรศึกษาระยะที่ 2 ประกอบด้วยสตรีไทยอายุ 31-86 ปี ที่อาศัยอยู่ในอำเภอชนบท จังหวัดขอนแก่น ในระหว่างปี พ.ศ. 2535 - พ.ศ. 2537 จำนวน 2,253 คน วิธีการเก็บข้อมูลประกอบด้วยการตรวจสุขภาพของปากและการสัมภาษณ์การวิเคราะห์ผล การศึกษากระทำทั้งแบบพรรณนา การวิเคราะห์ความสัมพันธ์ระหว่างตัวแปรสองตัว และการวิเคราะห์ความสัมพันธ์ ถดถอยแบบลอจิสติกที่มีตัวแปรต้นหลายตัว ผลการวิเคราะห์ความสัมพันธ์ถดถอยลอจิสติกในแบบจำลองสุดท้าย สำหรับการเคี้ยวหมากทั้ง 2 ระยะ พบความสัมพันธ์เชิงผกผันระหว่างการเคี้ยวหมากกับโรคฟันผุ โดยมีการควบคุมผล ของตัวแปรอื่น ๆ ในแบบจำลอง ส่วนผลการศึกษาที่พบจากแบบจำลองความสัมพันธ์สุดท้ายระหว่างการเคี้ยวหมาก กับโรคปริทันต์อักเสบสำหรับการเคี้ยวหมากทั้ง 2 ระยะ พบว่าการเคี้ยวหมากมีความสัมพันธ์ โดยตรงกับโรคปริทันต์อักเสบ ทามกลางปัจจัยรบกวนอื่น ๆ ที่ปรากฏในแบบจำลองสุดท้าย ผลจากการศึกษาที่สอดคล้องกันระหว่างข้อมูล ทั้งสองชุดบ่งชี้ว่า แม้ว่าการเคี้ยวหมากจะมีผลในทางทำให้เกิดโรคฟันผุน้อยลง แต่การเคี้ยวหมากมีความสัมพันธ์ โดยตรงกับโรคปริทันต์อักเสบ ซึ่งสามารถส่งผลให้มีความเสี่ยงต่อการสูญเสียฟันเพิ่มขึ้น ดังนั้นจึงควรมีการดำเนินการ เพื่อให้ประชาชนลดละเลิกพฤติกรรมเคี้ยวหมาก เพื่อนำไปสู่การมีสุขภาพ ของปากที่ดีต่อไป

## The natural history of periodontal disease in humans: risk factors for tooth loss in caries-free subjects receiving no oral health care.

Neely AL, Holford TR, L oe H, Anerud A, Boysen H.

Department of Periodontology and Dental Hygiene, School of Dentistry, University of Detroit, Mercy, Detroit, MI 48219-0900, USA. neelya@udmercy.edu

### Abstract

**AIM:** No long-term studies have reported on risk factors for tooth loss in subjects without home or professional dental care. The purpose of this report is to identify potential risk factors for tooth loss among male Sri Lankan tea labourers who participated in a 20-year investigation of the natural history of periodontal disease.

**MATERIAL AND METHODS:** Data for this report were obtained from the 455 subjects who participated in multiple examinations over the 20-year period from 1970 to 1990. Analyses included data from interim examinations in 1971, 1973, 1977, 1982 and 1985. Oral health assessments included the following: (1) attachment levels in millimetres on all mesial and mesio-buccal surfaces, excluding third molars; (2) plaque index; (3) gingival index; (4) calculus index; (5) caries index; and (6) missing teeth. Other variables included age, history of smoking and betel nut use. Statistical analyses included descriptive statistics and multivariate repeated-measures modelling with generalized estimating equations.

**RESULTS:** Tooth loss was significantly dependent upon interactions between the mean attachment loss and betel nut use ( $Z=3.40$ ;  $p=0.0007$ ) and history of missing teeth ( $Z=-3.70$ ;  $p=0.0002$ ). The effect of attachment loss on tooth loss was increased in the presence of betel nut and diminished when teeth were already missing at baseline.

**CONCLUSION:** History of missing teeth, betel nut use and increasing attachment loss were significant predictors of tooth loss over time. Betel nut use increased the effect of attachment loss on loss of teeth, while history of missing teeth diminished the effect of attachment loss on tooth loss.

1061  
B

## Association between smoking, betel chewing and gingival bleeding in rural Sri Lanka.

Amarasena N, Ekanayaka AN, Herath L, Miyazaki H.

Division of Preventive Dentistry, Department of Oral Health Science, Graduate School of Medical and Dental Sciences, Niigata University, Japan. najith@dent.niigata-u.ac.jp

### Abstract

**OBJECTIVE:** To ascertain the association between tobacco use and gingival bleeding in a rural community in Sri Lanka.

**MATERIAL AND METHODS:** A cross-sectional field-based study was carried out in 2178 rural males aged 20-60 years, employing a multistage cluster sampling technique. The levels of plaque and gingivitis were recorded on four sites of all teeth present excluding third molars, using the plaque index (PLI) and gingival index (GI). Information pertaining to sociodemographic variables, oral hygiene practices and tobacco consumption habits was obtained from all subjects.

**RESULTS:** One-way anova combined with the Bonferroni test disclosed that betel chewers had a significantly higher mean number of sites with gingival bleeding (22.6+/-21.8) than smokers (10.8+/-11.2) and nontobacco users (8.7+/-6.8) ( $p < 0.0001$ ). A higher proportion of betel chewers (55.1%) showed  $\geq 12$  bleeding sites compared to smokers (27.6%). Logistic regression analysis revealed that the association between betel chewing and gingival bleeding was positive (OR=2.41;  $p < 0.0001$ ) whereas that of smoking and gingival bleeding was negative (OR=0.75;  $p < 0.05$ ). Oral hygiene had the strongest relationship with gingival bleeding (OR=18.11).

**CONCLUSION:** While confirming the masking effect of smoking on gingival bleeding, these findings indicate that betel chewing might significantly enhance gingival bleeding in the population studied.

1/62  
E

Community Dent Oral Epidemiol. 2002 Apr;30(2):115-23.

## Tobacco use and oral hygiene as risk indicators for periodontitis.

Amarasena N, Ekanayaka AN, Herath L, Miyazaki H.

Division of Preventive Dentistry, Department of Oral Health Science, Graduate School of Medical and Dental Sciences, Niigata University, Niigata, Japan. najith@dent.niigata-u.ac.jp

Comment in:

- Community Dent Oral Epidemiol. 2003 Apr;31(2):158; author reply 159-60.

### Abstract

**OBJECTIVE:** To detect the periodontal status of male smokers and betel chewers in a rural community in Sri Lanka and compare it with that of male non-tobacco users of the same community.

**METHODS:** A cross-sectional community based study was carried out in a sample of 2277 rural adult males aged 20-60 years, adopting multistage cluster sampling technique. The present analysis was confined to 2178 subjects who were mutually exclusive smokers, betel chewers or non-tobacco users. The periodontal status was assessed by clinical measurement of levels of bacterial plaque (PLI), gingival inflammation (GI) and loss of epithelial attachment (LA). All measurements were carried out on four sites of all teeth present except third molars and the mean values for periodontal parameters were calculated.

**RESULTS:** Bivariate analysis revealed that the overall periodontitis levels were significantly higher in betel chewers and smokers than in non-tobacco users. Multiple linear regression analysis showed that there were no significant effects of smoking and betel chewing per se on LA, independent of age, socioeconomic status (SES) and whether or not controlled for PLI. The effect of the quantified tobacco use on LA was statistically significant regardless of age, PLI or SES. However, the effect of the quantified tobacco use was considered limited when compared to that of oral hygiene.

**CONCLUSIONS:** The findings highlighted the importance of oral hygiene in the aetiology of periodontitis while confirming the statistical significance of the quantified tobacco use on LA. Oral hygiene and the quantified tobacco use may be considered as risk indicators for periodontitis.

1063  
E

Journal of Zhejiang University-SCIENCE B (Biomedicine & Biotechnology)  
ISSN 1673-1581 (Print); ISSN 1862-1783 (Online)  
www.zju.edu.cn/jzus; www.springerlink.com  
E-mail: jzus@zju.edu.cn



## Chewing substances with or without tobacco and risk of cardiovascular disease in Asia: a meta-analysis\*

Li-na ZHANG<sup>1</sup>, Yun-mei YANG<sup>1†1</sup>, Zhe-rong XU<sup>1</sup>, Qi-feng GUI<sup>1</sup>, Qin-qing HU<sup>2</sup>

<sup>1</sup>Department of Gerontology, the First Affiliated Hospital, School of Medicine, Zhejiang University, Hangzhou 310003, China)

<sup>2</sup>Department of Nephrology, the First Affiliated Hospital, School of Medicine, Zhejiang University, Hangzhou 310003, China)

<sup>†</sup>E-mail: yunmei yang zju@hotmail.com

Received Apr. 10, 2010; Revision accepted Aug. 14, 2010, Crosschecked Aug. 17, 2010

**Abstract:** Objective: To assess whether people who ever use any form of chewing substance in Asia are at increased risk of cardiovascular disease (CVD). Methods: PubMed and ISI Web of Science were searched for relevant studies, with no limitation on language or study year. Studies were included if they provided quantitative estimate of the association between ever use of chewing substance and the occurrence of CVD. Two authors independently implemented inclusion criteria, abstracted study characteristics, and performed meta-analysis. Summary relative risks were estimated on the basis of a random effect model. We used Q statistic and Egger's test to examine heterogeneity across studies and potential publication bias, respectively. Results: Eight eligible studies were included. The relative risk of CVD for ever using chewing substances with or without tobacco was 1.26 (95% confidence interval (CI) 1.12–1.40), which was unchanged when restricted to cohort studies [1.25 (1.08–1.42)] or cohort studies in Taiwan [1.31 (1.12–1.51)]. The summary relative risk for ischemic heart disease was 1.27 (1.02–1.52), and was lowered to 1.26 (0.85–1.67) after exclusion of a cross-sectional study. The overall relative risk for cerebrovascular disease was 1.32 (1.08–1.56). On the basis of the Taiwan data, the summary relative risk of CVD for betel (*Areca catechu*) chewing was 1.30 (1.17–1.44). Data on dose-response were limited to betel chewing in Taiwan, suggesting a relationship between risk of CVD and cumulative exposure. Two large cohorts in Taiwan reported a greater risk of CVD with betel chewing than with smoking. Conclusions: An association was detected between betel chewing with or without tobacco and the risk of CVD. Betel chewing may impose a greater CVD risk than smoking. More effort is needed in developing betel chewing cessation programmes. The relationship between betel chewing and subgroups of CVD requires further investigation.

**Key words:** Cardiovascular disease, *Areca catechu*, Betel quid, Chewing tobacco, Relative risk, Meta-analysis  
doi:10.1631/jzus.B1000132 Document code: A CLC number: R54

### 1 Introduction

Various forms of smokeless tobacco, including chewing tobacco and paan, namely, *Areca catechu*/betel quid with tobacco, have been used in Asia for centuries. Betel quid is made up of fresh betel leaves, areca nut, and slaked lime, and can be served with or without tobacco (Gupta and Ray, 2004). Preparation

of betel quid varies from region to region, with the major difference being whether tobacco is added. To avoid a possible misnomer by classifying betel quid with some types of smokeless tobacco, while sometimes tobacco is actually absent, we herein employed the term "chewing substance" to refer to any type of chewing tobacco or betel quid with or without tobacco. Betel quid with tobacco is said to be one of the most commonly used forms of smokeless tobacco in South Asia (Gupta and Ray, 2003), whereas areca nut (usually incorporated in betel quid) ranks the fourth most common addictive substance in the world after

<sup>†</sup> Corresponding author  
\* Project (No. 2004C30067) supported by the Zhejiang Provincial Science and Technology Plan Project, China  
© Zhejiang University and Springer-Verlag Berlin Heidelberg 2010

1064

caffeine, tobacco, and alcohol (Gupta and Ray, 2004).

The complex nexus between chewing tobacco and betel quid is not easy to dissect. This, along with high prevalence of chewing tobacco and betel quid in South and Southeast Asia, exhibits a geographically unique scene of tobacco use, or more accurately, substance use other than the pandemic cigarette smoking (Rani *et al.*, 2003; Wen *et al.*, 2005; Teo *et al.*, 2006). Compared to cigarette smoking, which is a well established risk factor for cardiovascular disease (CVD), chewing tobacco and betel quid, though prevailing in many parts of Asia, are relatively less explored for their potential adverse effect on cardiovascular system. To date, few epidemiological studies have been conducted in Asia (Gupta *et al.*, 2005; Wen *et al.*, 2005; Teo *et al.*, 2006; Guh *et al.*, 2007; Lan *et al.*, 2007; Lin *et al.*, 2008; Rahman and Zaman, 2008; Yen *et al.*, 2008), investigating the relative risk of CVD related to chewing tobacco and betel quid, and the findings are not all comparable.

A recent meta-analysis indicated that smokeless tobacco users in Sweden and USA were at increased risk of CVD compared with nonusers (Boffetta and Straif, 2009). However, studies conducted in Asia were not included in view of heterogeneity between the contents of smokeless tobacco in Asia and those in Sweden and USA. Thus, the conclusion may not be readily applicable in the Asian context. Determining the roles of chewing tobacco and betel quid in CVD is important, given their high prevalence of usage and current high incidence and mortality of CVD in Asia. All these concerns prompted us to carry out a meta-analysis to summarize existing evidence, on the link between use of chewing substances and risk of CVD.

## 2 Methods

### 2.1 Searching strategy and selection criteria

The MOOSE guidelines for meta-analysis of observational studies in epidemiology were followed (Stroup *et al.*, 2000). We searched PubMed (up to July 2010), using the terms: ("cardiovascular diseases" [mesh] OR ("cardiovascular" [All Fields] AND "diseases" [All Fields]) OR "cardiovascular diseases" [All Fields] OR "cerebrovascular disorders" [mesh] OR ("cerebrovascular" [All Fields] AND "disorders" [All Fields]) OR "cerebrovascular disorders"

[All Fields] OR "stroke" [mesh] OR "stroke" [All Fields] OR mortality OR death\*) AND ("betel quid" OR "betel-quid" OR "betel nut" OR "betel nuts" OR "areca nut" OR "areca nuts" OR "paan" OR "pan" OR snuff OR snus OR "gul" OR "gutka" OR "khaini" OR "loose leaf" OR "maras" OR "mawa" OR "mishri" OR "naswar" OR "Areca catechu" OR "tooth powder" OR "shammah" OR "tobacco chewing gum" OR "zarda" OR "tobacco, smokeless" [mesh] OR "smokeless tobacco" OR "chewing tobacco" OR "non-smoking tobacco") AND ("cohort studies" [mesh] OR "cross-sectional studies" [mesh] OR "case control studies" [mesh] OR ("cohort" [TI] AND stud\* [TI]) OR (case\* [TI] AND control\* [TI]) OR prospective OR retrospective OR cross-sectional OR "cross sectional"), which yielded 1006 potentially relevant references. We adapted the searching strategy for a second search in ISI Web of Science (updated July 19, 2010), and found another 739 references. We identified all observational studies including cohorts, case-control studies, and cross-sectional studies, provided that they explored the association between ever using chewing substances and the occurrence (incidence or mortality) of CVD, and reported the strength of the associations with a quantitative risk estimate. There was no limitation on language, study year, or publication status.

After excluding duplicates, two authors independently reviewed all citations with titles and abstracts that appeared to fit the criteria for inclusion. We checked references of included studies and reviews to further identify other potentially eligible studies. The numbers of citations excluded and reason for exclusion were tracked.

### 2.2 Outcome measurement

We conducted the meta-analysis based on selected outcome measurements including cardiovascular disease (CVD), ischemic heart disease (IHD), and cerebrovascular disease (CBVD). The following sub section will describe in detail how these outcome measurements were identified.

### 2.3 Data extraction

Two authors independently extracted risk estimates and characteristics of each individual study. We followed the international classification code (ICD-9 and ICD-10) when grouping the extracted

outcome measurements. Accordingly, we regarded CVD as either 390–459 in ICD-9 or I00–I99 in ICD-10, IHD as either 410–414 in ICD-9 or I20–I25 in ICD-10, and CBVD as either 430–438 in ICD-9 or I60–I69 in ICD-10. When outcomes were not coded with an ICD number, we made assumptions according to the definition of diseases reported and how ascertainment was made. The extracted data were compared and any inconsistencies resolved. Wherever possible, data were extracted for fatal and non-fatal cardiovascular events.

If stratified results were presented from one study (for example, separate results for current and former use, for men and women), we combined them by carrying out a meta-analysis based on fixed effect model when  $Q$  statistic was not significant ( $P > 0.1$ ); otherwise we used a random effect model.

#### 2.4 Data synthesis and statistical analysis

A meta-analysis was made of the selected primary endpoint outcomes based on a random effect model (DerSimonian and Laird, 1986). We examined heterogeneity across studies with the  $Q$  statistic ( $P < 0.1$  considered significant). Egger's test was used to detect possible publication bias. All of analyses were conducted with the statistical package STATA (Version 11.0; Stata Corp, College Station, TX, USA).

We classified studies on the basis of the chosen outcomes (CVD, IHD, CBVD). In addition, we also classified studies by geographical region of study and study design (cohort, case-control) in the subgroup analysis. We accounted for concurrent smoking as a confounding factor, if a risk estimate was neither restricted to non-smokers nor obtained after adjustment for smoking; we considered it for sensitivity analysis by repeating the meta-analysis after exclusion of the study. Similarly, we repeated the meta-analysis after removing cross-sectional studies, and studies in which we had made any assumption about the classification of diseases. To minimize the confounding due to presence or absence of tobacco in chewing substances, which may be characteristic of different regions, we repeated the meta-analysis after stratification by geographical region. The possible influence of study design was assessed by repeating the main analysis with cohort study data only. To disentangle the effect of geographical region from

that of study design, we carried out a further meta-analysis restricted to cohort studies from Taiwan.

### 3 Results

Fig. 1 shows details of study identification, inclusion, and exclusion. A total of 1599 publications were initially screened. Eight studies met the criteria for inclusion in the present study.

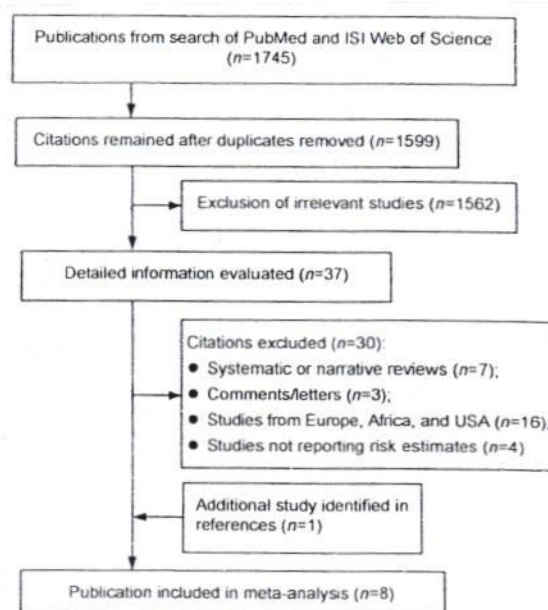

Fig. 1 Flow diagram of the study selection process

#### 3.1 Characteristics of included studies

Table 1 shows the characteristics of the included studies. All of the epidemiological studies were undertaken in South and East Asia in recent years. Five cohort studies were from India and Taiwan (China) (Gupta *et al.*, 2005; Wen *et al.*, 2005; Lan *et al.*, 2007; Lin *et al.*, 2008; Yen *et al.*, 2008), two used case-control design, one of which is a multi-center study (Teo *et al.*, 2006; Rahman and Zaman, 2008), and another one used cross-sectional design (Guh *et al.*, 2007). Of the eight studies included, four studies reported increased risk for use of chewing substance (Teo *et al.*, 2006; Lin *et al.*, 2008; Rahman and Zaman, 2008; Yen *et al.*, 2008), two showed inconsistent results between women and men (Gupta *et al.*,

1066

Table 1 Characteristics of included epidemiological studies on chewing substances and risk of CVD

Study	Geographical region, gender, recruitment, follow-up, No. of participants	Study design	Exposure	Outcome	Definition and ascertainment	No. of cases or deaths*	RR (95% CI)	Adjustment factors
Teo <i>et al.</i> , 2006	Mainly South Asia, both sexes, 1999–2003, NR, 27098	Case-control	Chewing tobacco	Acute myocardial infarction	Characteristic manifestation and ECG (specific criteria available)	NA	2.23 (1.41–3.52)	Age, gender, diabetes, abdominal obesity, hypertension, exercise, diet
Wen <i>et al.</i> , 2005	Taiwan (China), men, 1982–1992, 1982–2000, 19719	Cohort	Betel quid	CVD [390–459], IHD [410–414], stroke [430–438]	ICD-9, death registry system	275/39/86	1.1 (0.8–1.6), 1.0 (0.5–2.4), 1.3 (0.8–2.2)	Age, alcohol, education
Gupta <i>et al.</i> , 2005	India, both sexes, 1992–1994, 1992–1999, 97244	Cohort	Betel quid, areca nut, mishri	CVD [100–199], IHD [110, 111, 113, 121, 124, 125, 146, 150], CBVD [161–164, 166, 167]	ICD-10, death registry system	1876/1372/386	1.06 (0.84–1.33)*, 1.05 (0.76–1.47)*, 1.23 (0.97–1.55)*	Age, education
Rahman and Zaman, 2008	Bangladesh, both sexes, 2006–2007, NR, 207	Case-control	Betel quid, dried tobacco leaf	Coronary heart disease (acute myocardial infarction and angina pectoris)	Clinical findings and ECG	NA	2.8 (1.1–7.3)	Gender, age, hypertension
Yen <i>et al.</i> , 2008	Taiwan (China), men, 1999–2004, duration (2.81±1.50) years, 21906	Cohort	Betel quid	CVD [402, 410–414, 425–428, 430–438, 440–448]	ICD-9, incidence identified in hospital, mortality by registry system	3163	1.24 (1.11–1.39)	Age, education, occupation, smoking, alcohol, intake of fish, milk, coffee, physical activity, family history
Lan <i>et al.</i> , 2007	Taiwan (China), both sexes, 1989–2003; 1996–2003, 6511	Cohort	Betel quid	CVD [390–459], IHD [410–414], CBVD [430–438]	ICD-9, death registry system	684/153/305	1.41 (1.12–1.77), 1.22 (0.73–2.04), 1.66 (1.19–2.30)	Gender, age, living area, hypertension, anemia, heart disease, liver disease, arthritis, physical difficulty, smoking, alcohol
Lin <i>et al.</i> , 2008	Taiwan (China), men, 1998–1999, 1998–2005, 56116	Cohort	Betel quid	CVD [390–459]	ICD-9, death registry system	309	1.77 (1.31–2.40)*	Age, BMI, diabetes, hypertension, cholesterol, triglyceride, alcohol, smoking, physical activity, income, education
Guh <i>et al.</i> , 2007	Taiwan (China), both sexes, 1993–1996, NR, 1932	Cross-sectional	Betel quid	Heart disease	Questionnaires on self-report	NA	1.34 (1.12–1.62)*	Age, abdominal obesity, cholesterol, hypertension, diabetes, smoking, fruit intake

\* Number of cases or deaths from a certain outcome, cardiovascular disease (CVD), ischemic heart disease (IHD), cerebrovascular disease (CBVD), etc (listed in order in the fifth column). Cases or deaths of non-chewing smokers were not included. The numbers are listed in the same order to accompany their corresponding outcomes. \* Results of meta-analysis. RR: relative risk; CI: confidence interval; NR: not relevant; NA: not available; ECG: electrocardiograph; ICD: international classification code; BMI: body mass index

1067

2005; Guh *et al.*, 2007), one found inconsistency between subtypes of CVD (Lan *et al.*, 2007), and still another one reported negative results (Wen *et al.*, 2005). Four studies (Gupta *et al.*, 2005; Teo *et al.*, 2006; Lin *et al.*, 2008; Rahman and Zaman, 2008) reported risk estimates of substance chewers restricted to never tobacco smokers, whereas the others all included cigarette smokers in both categories (Wen *et al.*, 2005; Lan *et al.*, 2007; Guh *et al.*, 2007; Yen *et al.*, 2008), and could not report the relative risk of chewing betel quid alone. In the latter, however, risk estimates were all adjusted for cigarette smoking, except in one study (Wen *et al.*, 2005).

Three studies (Wen *et al.*, 2005; Lan *et al.*, 2007; Lin *et al.*, 2008) mentioned that betel quid in Taiwan was generally chewed without tobacco. The betel quid was commonly used with added tobacco elsewhere in South Asia (Gupta and Ray, 2004), though it was not the case in the Mumbai cohort, where betel quid was chewed without tobacco (Gupta *et al.*, 2005). Meta-analyses of stratified results were performed for three studies to obtain a summary relative risk (Gupta *et al.*, 2005; Guh *et al.*, 2007; Lin *et al.*, 2008).

### 3.2 Chewing substances and risk of CVD

On the basis of six risk estimates, the overall relative risk of CVD (ICD-9: 390-459; ICD-10: 100-199) for ever using chewing substances was 1.26 (95% confidence interval (CI) 1.12-1.40), with no evidence of heterogeneity among studies (Table 2, Fig. 2; test for publication bias  $P=0.68$ ). Restricting the meta-analysis to cohort studies yielded a summary relative risk of 1.25 (1.08-1.42) based on five risk estimates. The summary relative risk of CVD for betel chewing was 1.30 (1.17-1.44) based on five studies from Taiwan. Data from cohort studies in Taiwan gave a summary relative risk of 1.31 (1.12-1.51) based on four risk estimates. An increased risk of death from CVD was present, 1.28 (1.00-1.56) based on four risk estimates. After removing one study that did not report a risk estimate after adjustment for smoking (Wen *et al.*, 2005), the positive direction of relative risks all persisted, except for the fatal form of CVD (data not shown).

Dose-response analysis for CVD was reported in three studies in Taiwan (Lan *et al.*, 2007; Lin *et al.*, 2008; Yen *et al.*, 2008), and significant trends in risk by cumulative exposure were detected in two studies

**Table 2 Results of meta-analysis on risk of CVD and chewing substances with or without tobacco**

Outcome and subgroups	No. of risk estimates	$P^*$	RR (95% CI)
<b>CVD</b>			
Overall	6	0.17	1.26 (1.12-1.40)
Cohort	5	0.13	1.25 (1.08-1.42)
Taiwan	5	0.29	1.30 (1.17-1.44)
Cohort Taiwan	4	0.19	1.31 (1.12-1.51)
Fatal	4	0.07	1.28 (1.00-1.56)
<b>IHD</b>			
Overall	6	0.29	1.27 (1.02-1.52)
Cohort	3	0.89	1.08 (0.78-1.38)
South Asia	3	0.07	1.64 (0.60-2.68)
Taiwan	3	0.77	1.31 (1.08-1.53)
Cohort Taiwan	2	0.71	1.15 (0.61-1.70)
Fatal	3	0.89	1.08 (0.78-1.38)
<b>CBVD</b>			
Overall	3	0.40	1.32 (1.08-1.56)
Taiwan	2	0.43	1.52 (1.09-1.96)

\*  $P$  for heterogeneity. CVD: cardiovascular disease; IHD: ischemic heart disease; CBVD: cerebrovascular disease, RR: relative risk; CI: confidence interval

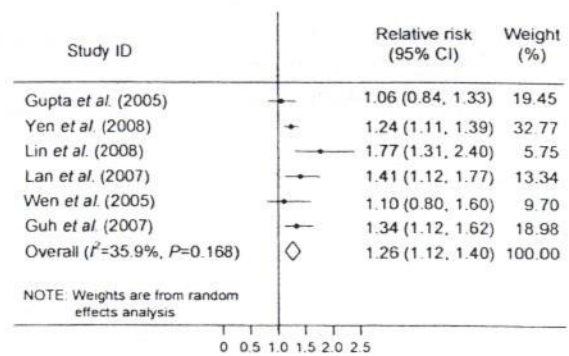

**Fig. 2 Forest plot of risk estimates for CVD among users of chewing substances**

(Lan *et al.*, 2007; Yen *et al.*, 2008). In the third study (Lin *et al.*, 2008), though the analysis for trend was not reported, the relative risk of fatal CVD was the highest in the groups of subjects using betel quid most often. In addition, two of these large cohorts (Lin *et al.*, 2008; Yen *et al.*, 2008) reported a greater risk of CVD caused by betel chewing than smoking. In Yen *et al.* (2008)'s study, the relative risks (95% CI) of CVD for betel chewing and smoking were 1.24 (1.11-1.39) and 0.96 (0.89-1.04), respectively. Lin *et al.* (2008) calculated that betel nut chewers had a higher risk of CVD mortality (relative risk 2.10;  $P<0.05$ ) than did smokers.

1068

### 3.3 Chewing substances and risk of IHD

An increased risk of IHD (ICD-9, 410-414; ICD-10: I20-I25) was observed, with a summary relative risk of 1.27 (1.02-1.52) on the basis of six risk estimates (Table 2; test for publication bias  $P=0.60$ ). However, the relative risk effect became insignificant after the removal of the cross-sectional study of Guh *et al.* (2007), resulting in a summary risk estimate of 1.26 (0.85-1.67). The inconsistency between main analysis and subsequent sensitivity analysis indicated that a significant effect reached by main analysis may be heavily influenced by one single study. Thus, the result should be interpreted with caution. Restricting the meta-analysis to cohort studies (three risk estimates) or studies in South Asia (three risk estimates) did not show a marked increased risk, though the trend was toward positive (Table 2). Studies carried out in Taiwan revealed an increased risk of 1.31 (1.08-1.53), but again the effect appeared non-significant after exclusion of the same cross-sectional study where "heart disease" was recalled by patients rather than being diagnosed in hospital or classified with specific criteria (Guh *et al.*, 2007).

Of note, there were two case-control studies that investigated the incidences of "coronary heart disease" and "acute myocardial infarction" (one of them being a multi-center study), and both showed marked increase of risk in tobacco chewers in South Asia (Teo *et al.*, 2006; Rahman and Zaman, 2008).

### 3.4 Chewing substances and risk of CBVD

Only three estimates (Gupta *et al.*, 2005; Wen *et al.*, 2005; Lan *et al.*, 2007) were available for CBVD (ICD-9: 430-438; ICD-10: I60-I69; all in fatal form), resulting in an overall relative risk of 1.32 (1.08-1.56) (Table 2; test for publication bias  $P=0.76$ ). No heterogeneity was observed. Given the limited number of studies, we did not perform further subgroup analysis.

## 4 Discussion

Our meta-analysis showed an increased risk of CVD among users of chewing substances with or

without tobacco compared with non-users. Study data from Taiwan indicated significantly increased CVD risk in relation to betel chewing. When meta-analyses were confined to cohort studies or cohort studies in Taiwan, the positive effects remained significant. This was further confirmed by subsequent sensitivity analysis by removing the studies that either did not report an adequately adjusted risk estimate (Wen *et al.*, 2005) or defined the outcome measurement less clearly (Guh *et al.*, 2007). The magnitudes of the excess risks for CVD and CBVD were both small, but the results were produced on the basis of several studies with large numbers of participants. The consistency of results among studies, and their robustness for study design and quality also added to their credibility. The meta-analysis for IHD, however, showed inconsistency, when a sensitivity analysis was undertaken. Further grouping the meta-analysis by study design or geographical region did not show the evidence of excess risk for IHD.

Several explanations may be given for the discrepancy in results between CVD in total and subtypes of CVD, such as IHD. First of all, numbers of IHD cases included may be relatively small. For example, four out of six studies had included no more than 200 IHD cases or deaths in each (Wen *et al.*, 2005; Lan *et al.*, 2007; Guh *et al.*, 2007; Rahman and Zaman, 2008). Small study population may be underpowered to detect a possible association. However, this was not the case in the Mumbai cohort study (Gupta *et al.*, 2005), which documented a total of 1372 IHD deaths (631 men and 741 women), though an increased risk was found only in women. Gupta *et al.* (2005) reasoned that cause-specific death rates could be underestimated, since nearly a quarter of total deaths could not be matched. Of note, identification of IHD deaths in this cohort showed a wider range than those in the other studies (Table 1), which might be a source of inconsistent results among studies. Furthermore, it was also noted that misclassification for the cause of death may well be possible even within a high quality death registering system (Gupta *et al.*, 2005). It is unclear, however, how misclassification of fatal IHD could generate a false negative result in cohort studies, since misclassification would most likely be non-discriminatory for the exposure status (Rothman and Greenland, 1998). In

any case, misclassification could have little influence on the identification of CVD in total. Since diseases of other systems were much less likely to be classified as circulatory diseases, while various diseases within the group of recognized CVD may be mistaken for each other.

Moreover, the meta-analysis for the risk of CVD in total was largely based on four cohort studies in Taiwan (Wen *et al.*, 2005; Lan *et al.*, 2007; Lin *et al.*, 2008; Yen *et al.*, 2008) where betel quid was chewed without tobacco (Wen *et al.*, 2005). Meta-analysis based on Taiwan data showed increased risk of CVD for betel chewing, relative risk 1.30 (1.17–1.44) based on five risk estimates. When it was confined to cohort studies in Taiwan, the positive direction persisted, and was not swerved by exclusion of the very study in which risk estimate was not adjusted for cigarette smoking (Wen *et al.*, 2005). In addition, two large cohorts in Taiwan (Lin *et al.*, 2008; Yen *et al.*, 2008) reported a greater risk of CVD from betel chewing than from smoking. The consistency between main analysis and sensitivity analysis, together with dose-response effect in several of these studies, attested to the evidence that betel chews free of tobacco can be harmful to cardiovascular system, though further classified subtypes of CVD were less studied for betel chewing. On the other hand, however, concerning chewing substances with tobacco, only one cohort study (Gupta *et al.*, 2005) was available for the risk estimate of CVD in total, where increased relative risk was found only in women. In contrast, the two case-control studies including both sexes (Teo *et al.*, 2006; Rahman and Zaman, 2008) have explored exclusively the relationship between coronary heart disease and use of chewing tobacco, which supported a positive link. Given these concerns, more investigations are needed to explore the risks for specific subgroups of CVD in relation to the use of betel chews with or without tobacco, but this would have to rely on specific and accurate classification of specific CVD forms and of specific CVD events.

The underlying mechanisms for the link between chewing substance and CVD may be multiple. Nicotine and arecoline, the predominant alkaloids that were found, respectively, in tobacco and betel quid (*Areca catechu*), are recognized for their short-term effects in causing increased heart rate and blood

pressure (Benowitz and Gourlay, 1997; Boucher and Mannan, 2002). Recent studies both in India and Taiwan have found that tobacco chewers and betel chewers were more prone to have dyslipidemia and hypertension (Khurana *et al.*, 2000; Chung *et al.*, 2006; Gupta *et al.*, 2007; Tseng, 2008), which are traditional risk factors of CVD. It may well raise the suspicion that some chemicals from these chewing substances may trigger specific biochemical reactions related to dyslipidemia and hypertension, which in turn lead to cardiovascular events. In addition, chewing itself may lead to susceptibility to periodontal diseases, which are potentially associated with cardiovascular malfunction (Ling *et al.*, 2001; Janket *et al.*, 2003). The detailed mechanism by which these processes are involved in the development of CVD remains unclear and merits further investigation.

Our findings extend the conclusion reached by a previous meta-analysis which indicated an association between smokeless tobacco and risk of CVD based on studies carried out in the United States and Sweden (Boffetta and Straif, 2009). To explore the associations of tobacco/betel chewing and CVD risks in Asia, we carried out a meta-analysis based on explicit criteria for inclusion of studies, extraction, and pooling of results. By summarizing the existing evidence quantitatively, we obtained a more precise risk estimate with a narrowed confidence interval, and thus increased the power to detect a link between use of betel quid and risk of CVD. The results included in the meta-analysis were adjusted for other known risk factors of CVD, such as hypertension, obesity, and education level.

Our study also has some limitations. First, it was unclear whether substance chewers would change their habit during follow-up in the cohort study. It might generate a false positive effect if chewers shifted to smoking. However, evidence supporting chewing tobacco or betel quid as a "gateway" to smoking was lacking in Asia. In fact, Taiwan data indicated that smoking appeared a "gateway" for betel quid chewing while smokers rarely started chewing first (Wen *et al.*, 2005). Second, confounding by cigarette smoking might be a potential source of bias. Still this meta-analysis has very few studies suitable to use, and not all studies reported the relative risk confined to non-smokers. However, the numbers

1670  
k

of participants in most of these studies were large, and in three of the four studies (Guh *et al.*, 2007; Lan *et al.*, 2007; Yen *et al.*, 2008) where smokers were included, risk estimates were all reported after adjustment of smoking status. The other study (Wen *et al.*, 2005) was removed in the sensitivity analysis, without altering the findings. Third, we did not perform meta-analysis stratified by gender, given lack of data. Very few women in Taiwan use betel quid (Wen *et al.*, 2005; Lin *et al.*, 2008), and in fact, three large cohorts in Taiwan investigated male participants exclusively (Wen *et al.*, 2005; Lin *et al.*, 2008; Yen *et al.*, 2008). Furthermore, only one large cohort (Gupta *et al.*, 2005) and another two studies (Guh *et al.*, 2007; Rahman and Zaman, 2008) reported relative risk for females separately. However, the latter two included far less cases compared to other studies, making it meaningless to stratify the data by gender. Finally, in consideration of possible heterogeneity, we used a random effect model which may result in wider confidence intervals, and thus a more conservative estimate of effect.

In conclusion, a meta-analysis was carried out on studies of betel chewing in Asia, with and without tobacco, in relation to CVD risks. A direct association was detected, though the results on subgroups of CVD were less convincing. Furthermore, betel chewing may impose a greater CVD risk than smoking. More effort on developing betel chewing cessation programmes is urgently warranted. Further studies are needed to elucidate whether a similar effect is present for different subgroups of CVD and to clarify the mechanisms of the effect of chewing tobacco and betel quid on the occurrence of CVD.

## 5 Acknowledgements

The authors express their sincere thanks to the international peer referees for improving this paper.

## References

- Benowitz, N.L., Gourlay, S.G., 1997. Cardiovascular toxicity of nicotine: implications for nicotine replacement therapy. *J. Am. Coll. Cardiol.*, **29**(7):1422-1431. [doi:10.1016/S0735-1097(97)00079-X]
- Boffetta, P., Straif, K., 2009. Use of smokeless tobacco and risk of myocardial infarction and stroke: systematic review with meta-analysis. *BMJ*, **339**:b3060. [doi:10.1136/bmj.b3060]
- Boucher, B.J., Mannan, N., 2002. Metabolic effects of the consumption of *Areca catechu*. *Addict. Biol.*, **7**(1): 103-110. [doi:10.1080/13556210120091464]
- Chung, F.M., Chang, D.M., Chen, M.P., Tsai, J.C., Yang, Y.H., Shieh, T.Y., Shin, S.J., Chen, T.H., Tai, T.Y., Lee, Y.J., 2006. Areca nut chewing is associated with metabolic syndrome: role of tumor necrosis factor-alpha, leptin, and white blood cell count in betel nut chewing-related metabolic derangements. *Diabetes Care*, **29**(7):1714. [doi:10.2337/dc06-0628]
- DerSimonian, R., Laird, N., 1986. Meta-analysis in clinical trials. *Control. Clin. Trials*, **7**(3):177-188. [doi:10.1016/0197-2456(86)90046-2]
- Guh, J.Y., Chen, H.C., Tsai, J.F., Chuang, L.Y., 2007. Betel-quid use is associated with heart disease in women. *Am. J. Clin. Nutr.*, **85**(5):1229-1235.
- Gupta, B.K., Kaushik, A., Panwar, R.B., Chaddha, V.S., Nayak, K.C., Singh, V.B., Gupta, R., Raja, S., 2007. Cardiovascular risk factors in tobacco-chewers: a controlled study. *J. Assoc. Phys. India*, **55**:27-31.
- Gupta, P.C., Ray, C.S., 2003. Smokeless tobacco and health in India and South Asia. *Respirology*, **8**(4):419-431. [doi:10.1046/j.1440-1843.2003.00507.x]
- Gupta, P.C., Ray, C.S., 2004. Epidemiology of betel quid usage. *ANNALS Acad. Med. Singapore*, **33**(Suppl. 4): 31-36.
- Gupta, P.C., Pednekar, M.S., Parkin, D.M., Sankaranarayanan, R., 2005. Tobacco associated mortality in Mumbai (Bombay) India. Results of the Bombay cohort study. *Int. J. Epidemiol.*, **34**(6):1395-1402. [doi:10.1093/ije/dyi196]
- Janket, S.J., Baird, A.E., Chuang, S.K., Jones, J.A., 2003. Meta-analysis of periodontal disease and risk of coronary heart disease and stroke. *Oral. Surg. Oral. Med. Oral. Pathol. Oral. Radiol. Endod.*, **95**(5):559-569. [doi:10.1067/moe.2003.107]
- Khurana, M., Sharma, D., Khandelwal, P.D., 2000. Lipid profile in smokers and tobacco chewers: a comparative study. *J. Assoc. Phys. India*, **48**(9):895-897.
- Lan, T.Y., Chang, W.C., Tsai, Y.J., Huang, Y.L., Lin, H.S., Tai, T.Y., 2007. Areca nut chewing and mortality in an elderly cohort study. *Am. J. Epidemiol.*, **165**(6):677-683. [doi:10.1093/aje/kwk056]
- Lin, W.Y., Chiu, T.Y., Lee, L.T., Lin, C.C., Huang, C.Y., Huang, K.C., 2008. Betel nut chewing is associated with increased risk of cardiovascular disease and all-cause mortality in Taiwanese men. *Am. J. Clin. Nutr.*, **87**(5): 1204-1211.
- Ling, L.J., Hung, S.L., Tseng, S.C., Chen, Y.T., Chi, L.Y., Wu, K.M., Lai, Y.L., 2001. Association between betel quid chewing, periodontal status and periodontal pathogens. *Oral Microbiol. Immunol.*, **16**(6):364-369. [doi:10.1034/j.1399-302X.2001.160608.x]
- Rahman, M.A., Zaman, M.M., 2008. Smoking and smokeless tobacco consumption: possible risk factors for coronary

1071  
f

- heart disease among young patients attending a tertiary care cardiac hospital in Bangladesh. *Public Health*, **122**(12):1331-1338. [doi:10.1016/j.puhe.2008.05.015]
- Rani, M., Bonu, S., Jha, P., Nguyen, S.N., Jamjoum, L., 2003. Tobacco use in India: prevalence and predictors of smoking and chewing in a national cross sectional household survey. *Tobacco Control*, **12**(4):e4. [doi:10.1136/tc.12.4.e4]
- Rothman, K.J., Greenland, S., 1998. Precision and Validity in Epidemiologic Studies. In: Rothman, K.J., Greenland, S. (Eds.), *Modern Epidemiology*, 2 Ed. Lippincott-Raven, Philadelphia, PA, p 15-34.
- Stroup, D.F., Berlin, J.A., Morton, S.C., Olkin, I., Williamson, G.D., Rennie, D., Moher, D., Becker, B.J., Sipe, T.A., Thacker, S.B., 2000. Meta-analysis of observational studies in epidemiology: a proposal for reporting meta-analysis of observational studies in epidemiology (MOOSE) group. *JAMA*, **283**(15):2008-2012. [doi:10.1001/jama.283.15.2008]
- Teo, K.K., Ounpuu, S., Hawken, S., Pandey, M.R., Valentin, V., Hunt, D., Diaz, R., Rashed, W., Freeman, R., Jiang, L., et al., 2006. Tobacco use and risk of myocardial infarction in 52 countries in the INTERHEART study: a case-control study. *The Lancet*, **368**(9536):647-658. [doi:10.1016/S0140-6736(06)69249-0]
- Tseng, C.H., 2008. Betel nut chewing is associated with hypertension in Taiwanese type 2 diabetic patients. *Hypertens. Res.*, **31**(3):417-423. [doi:10.1291/hyres.31.417]
- Wen, C.P., Tsai, S.P., Cheng, T.Y., Chen, C.J., Levy, D.T., Yang, H.J., Eriksen, M.P., 2005. Uncovering the relation between betel quid chewing and cigarette smoking in Taiwan. *Tobacco Control*, **14**(Suppl. 1):i16-i22. [doi:10.1136/tc.2004.008003]
- Yen, A.M., Chen, L.S., Chiu, Y.H., Boucher, B.J., Chen, T.H., 2008. A prospective community-population-registry based cohort study of the association between betel-quid chewing and cardiovascular disease in men in Taiwan. *Am. J. Clin. Nutr.*, **87**(1):70-78.

## New Website, More Information in 2010

<http://www.zju.edu.cn/jzus>; <http://www.springerlink.com>



**JOURNAL OF ZHEJIANG UNIVERSITY**  
**SCIENCE ABC**

---

**Home** | **Current Issue** | **Online Submission** | **Readers Register** | **Contact Us**

**CONTENTS**

- Current Issue
- Back Issue
- Online First
- Subscription

**INSTR. FOR AUTHOR**

- Preparing Manuscript
- Online Submission
- Revision & Acceptance
- Cross Check
- Call for paper

**FOR REVIEWER**

- Inv. Reviewer
- Guidelines for Reviewer

**ABOUT JZUS**

- Editorial Board
- Journal Link
- JZUS Events
- Contact Us

**Journals**

**Journal of Zhejiang University-SCIENCE A (Applied Physics & Engineering)**  
ISSNs 1673-565X (Print); 1862-1775 (Online); started in 2009, Monthly.

JZUS-A is an international "Applied Physics & Engineering" reviewed Journal indexed by SCIE, Ei Compendex, INSPEC CA, SA, IST, AJ, ZN, CABL, ZR, CSA, etc. It mainly covers research in Applied Physics, Mechanical and Civil Engineering, Environmental Science and Energy, Materials Science and Chemical Engineering, etc.

**Journal of Zhejiang University-SCIENCE B (Biomedicine & Biotechnology)**  
ISSNs 1673-1581 (Print); 1862-1783 (Online); started in 2009, Monthly.

JZUS-B is an international "Biomedicine & Biotechnology" reviewed Journal indexed by SCIE, MEDLINE, PMC, SA, BIOSIS Previews, JST, ZR, CA, SA, AJ, ZN, CABL, CSA, etc., and supported by the National Natural Science Foundation of China. It mainly covers research in Biomedicine, Biochemistry and Biotechnology, etc.

**Journal of Zhejiang University-SCIENCE C (Computers & Electronics)**  
ISSNs 1869-1951 (Print); 1868-1963 (Online); starts in 2010, Monthly.

JZUS-C is an international "Computers & Electronics" reviewed Journal indexed by SCIE, Ei Compendex, DBLP, IC, Scopus, JST, CSA, etc. It covers research in Computer Science, Electrical and Electronic Engineering, Information Science, Automation, Control, Telecommunications, as well as Applied Mathematics related to Computer Science.

**Top 10 cited A B**

- Optimal choice of parameter
- Hybrid discrete particle sw
- How to realize a negative r
- Three-dimensional analysis
- THE POLYMERIZATION OF
- METHYL

[more](#)

**Newest cited A B C**

- Investigation of migration
- Self-certified multi-proce
- Control strategy of hybrid
- Improved Finite-Element
- Application of honey-bee ma

[more](#)

**Top 10 DOIs Monthly**

- A numerical analysis to the
- Parameter effects on the dy
- Model-based testing with UM
- Temporal variance in modal
- Preface

[more](#)

**Newest 10 comments**

- Buckling of un-stiffened co
- Prediction and analysis mod
- Assessment of rice fields b
- Construction and character
- Synthesis of acetals and ke

[more](#)

\* In the Web of Science, search for "JOURNAL OF ZHEJIANG UNIVERSITY-SCIENCE C"

In 2009 JCR of Thomson Reuters, the Impact Factor of JZUS-A is 0.901, and the Impact Factor of JZUS-B is 1.041

1072  
k

# Betel-quid use is associated with heart disease in women<sup>1-4</sup>

Jinn-Yuh Guh, Hung-Chun Chen, Jung-Fa Tsai, and Lea-Yea Chuang

## ABSTRACT

**Background:** Betel quid (*Areca catechu*) is used by ≈10% of the world population. Betel-quid use is associated with the metabolic syndrome—a risk factor for heart disease.

**Objective:** The objective was to test whether betel-quid use is associated with heart disease in adults.

**Design:** Nonpregnant adults aged 20–64 y (*n* = 1932, 52% women) from the nationally representative Nutrition and Health Survey in Taiwan (1993–1996) were studied for independent associations between betel-quid use and heart disease after adjustment for lifestyle factors, age, obesity, diabetes mellitus, hypertension, and concentrations of serum total cholesterol and HDL cholesterol.

**Results:** The prevalence of betel-quid use was higher in men than in women (31% compared with 2.4%; *P* < 0.001). The prevalence of heart disease was not significantly different between men and women (3.3% compared with 2.3%; *P* = 0.12). The prevalence of betel-quid use decreased, whereas the prevalence of heart disease increased, with age. Betel-quid users were younger, drank more, had a lower dietary fruit intake, had a higher Framingham risk score, and had higher serum triacylglycerol concentrations than did the nonusers. At a mean consumption rate of 10 times/d (the third quartile of betel-quid consumption in betel-quid users), betel-quid use was independently associated with the Framingham risk score in subjects without heart disease only if obesity was not included as an adjustment factor (*P* = 0.007). Moreover, the daily rate of betel-quid use was independently associated with prevalent heart disease; the odds ratio associated with a betel-quid consumption rate of 10 times/d was 1.37 (95% CI: 1.1, 1.6; *P* = 0.003) in women.

**Conclusion:** Betel-quid use is independently associated with heart disease in women. *Am J Clin Nutr* 2007;85:1229–35.

**KEY WORDS** Betel quid, *Areca catechu*, heart disease, Framingham risk score, diabetes, metabolic syndrome

## INTRODUCTION

Heart disease is the leading cause of death worldwide (1). Moreover, about one-half of the world's future heart disease burden is predicted to occur in the Asia-Pacific region (2). The cardinal risk factors for heart disease include obesity, hyperlipidemia, hypertension, diabetes mellitus (DM), and smoking (2, 3). In contrast, moderate alcohol drinking may protect against heart disease (4, 5).

Many of the risk factors for heart disease have reached epidemic proportions worldwide. The world population in the year 2000 was 6 billion (6); the global burden of obesity or overweight was 1.3 billion people (7), of hypertension was 1 billion (8), and of DM was 150 million people (9). The number of patients with

DM is predicted to rise to 300 million in the year 2025, the majority of whom will be in Asia (10). Obesity, hypertension, and DM are frequently associated with hypertriglycerolemia and low HDL-cholesterol concentrations—2 conditions that are independently associated with coronary artery diseases (11).

Betel quid (*Areca catechu*), usually chewed in combination with *Piper betle* (inflorescence or leaf) and lime (12), is used by ≈10% of the world population, including Taiwan (13). Betel-quid use is associated with the risk of oral cancer, liver cirrhosis, and hepatocellular carcinoma (14, 15). Moreover, we and others have shown that betel-quid use is associated with obesity, hypertension, DM, hyperlipidemia, and the metabolic syndrome (16–18)—the cardinal risk factors for heart disease (2, 3). Indeed, sporadic case reports suggest that betel-quid use may predispose to acute myocardial infarction (19, 20) and cardiac arrhythmias (21).

Therefore, data from the stratified multistage probability-sampled Nutrition and Health Survey in Taiwan (NAHSIT, 1993–1996) (22, 23) was used to study the association between betel-quid use and heart disease in adults.

## SUBJECTS AND METHODS

### Study population

NAHSIT was a stratified multistage probability-sampled study (22, 23). The detailed procedure of the study was described in our previous study (18). Briefly, Taiwan (with ≈21 million inhabitants in 1993–1996) was stratified into 7 strata, and 3 townships in each stratum were selected with the selection probability proportional to the population size of the township. A total of 9961 persons aged 4–96 y were recruited. Nonpregnant adults aged 20–64 y (*n* = 3910) were included in this study. This study

<sup>1</sup> From the Departments of Internal Medicine (J-YG, H-CC, and J-FT) and Biochemistry (L-YC), Faculty of Medicine, and the Department of Internal Medicine (J-YG, H-CC, and J-FT), Kaohsiung Medical University Hospital, Kaohsiung Medical University, Kaohsiung, Taiwan.

<sup>2</sup> The views expressed herein are solely those of the authors.

<sup>3</sup> Supported by grant no. DOH93-TD-D-113-021(2) from the Department of Health, Taiwan. NAHSIT was sponsored by the Department of Health in Taiwan (DOH FN8202, DOH-83-FS-41, DOH-84-FS-11, DOH-85-FS-11, and DOH-86-FS-11) and carried out by Wen-Harn Pan (Institute of Biomedical Sciences, Academia Sinica) and Po-Chao Huang (Department of Biochemistry, National Taiwan University).

<sup>4</sup> Reprints not available. Address correspondence to L-Y Chuang, Department of Biochemistry, Kaohsiung Medical University, 100 Zihyou 1st Road, Kaohsiung, Taiwan 807. E-mail: jyuh@mail.nsysu.edu.tw.  
Received August 10, 2006.

Accepted for publication December 6, 2006.



1073

was approved by the institutional ethics committee. All NAHSIT enrollees provided written informed consent.

Enrollees who had not received a physical examination or phlebotomy ( $n = 970$ ), who had fasted for  $<8$  h ( $n = 148$ ), who had hemolyzed blood ( $n = 109$ ), or who had missing data on betel-quid use ( $n = 42$ ), smoking or drinking ( $n = 93$ ), DM or hypertension ( $n = 31$ ), blood glucose ( $n = 140$ ), serum biochemistry (total cholesterol, triacylglycerol, and HDL cholesterol) ( $n = 649$ ), or dietary intakes (sodium and protein) ( $n = 50$ ). Thus, the data from a total of 1932 persons were available for analysis in this study. Note that some participants met more than one exclusion criteria.

### Interview

The details of the interview and physical examination were described in our previous study (18). Briefly, the household interview and physical examination were completed by trained technicians (23). Dietary intakes for those aged 20–64 y were estimated from a 24-h dietary recall and a food-frequency questionnaire. The food-frequency questionnaire (24) estimated the frequency of intake of 36 food items within 1 mo. The 24-h dietary recall (25) included a recall of foods consumed within the 24 h before the administration of the 24-h dietary-recall questionnaires. Nutrient intakes were calculated from each food item based on the Nutrient Composition Data Bank for Foods of Taiwan Area (26). Intakes of carbohydrate, fat, and protein were expressed as a percentage of daily energy intake.

Smoking was coded as pack-years [packs (20 cigarettes per pack)/d  $\times$  years]. Alcoholic drinks in Taiwan were classified into 9 categories according to the concentration of alcohol (27), and alcohol drinking was coded as drink-years (drinks/d  $\times$  years). Note that a "drink" was defined as the amount of an alcoholic drink that contains 0.5 oz (13.7 g) of alcohol (5). Alcohol drinking status was classified into nil, moderate ( $\leq 1$  drink/d for women and  $\leq 2$  drinks/d for men), and heavy ( $> 1$  drink/d for women and  $> 2$  drinks/d for men) (5). Betel-quid use was coded in 2 ways: 1) yes or no and 2) times/d.

Body weight was measured with the use of a weighing scale, while the subjects were wearing light clothing, to the nearest 0.1 kg (18). Body height without shoes was measured to the nearest 0.1 cm in a standing position (18). Waist circumference was measured horizontally with the use of a soft measuring tape at the level of the natural waist, which was identified as the level at the hollow molding of the trunk when the trunk was bent laterally (28).

Blood pressure was measured with a mercury sphygmomanometer after the subjects had rested for 5 min in the supine position (29). Systolic and diastolic blood pressures were recorded as the first and fifth phases of Korotkoff sounds, respectively. Two blood pressure measurements were made 30 s apart. If the 2 measurements differed by  $> 10$  mm Hg, a third measurement was made and the 2 closest readings were averaged. The weighing scale, measuring tapes, and mercury sphygmomanometer were standardized by Bureau of Standards, Metrology and Inspection—authorized agencies initially and at 6-mo intervals (18).

Hypertension was defined as a blood pressure  $\geq 140$  (systolic)/90 (diastolic) mm Hg, physician-diagnosed hypertension, or current use of antihypertensive agents. DM was defined as a fasting (whole) blood glucose concentration  $\geq 110$  mg/dL, physician-diagnosed DM, or current use of hypoglycemic agents. Abdominal obesity was defined as a waist circumference  $> 90$  cm in men and a waist circumference  $> 80$  cm in women for

Asians (30, 31). The definition of the metabolic syndrome was modified from that of the National Cholesterol Education Program Adult Treatment Panel III (3, 32), as described in our previous study (18).

Heart disease was defined as an answer of "yes" to the question, "Do you have a physician-diagnosed heart disease?". Note that "heart disease" in this study refers to prevalent (current) heart disease instead of incident (new onset) heart disease. The Framingham risk score, which was based on sex, age, cholesterol, HDL cholesterol, blood pressure, DM, and smoking, was calculated to provide an estimate of 10-y coronary risk (33) in NAHSIT participants without heart disease.

### Measurements

Fasting whole-blood glucose was measured by using the glucose oxidase method (portable model 23A; YSI Co., Taipei, Taiwan) immediately after blood was drawn. Fasting morning blood samples were drawn and centrifuged ( $1000 \times g$ , 15 min,  $4^\circ\text{C}$ ) on site (18). Serum was stored at  $-70^\circ\text{C}$  until total cholesterol, HDL-cholesterol, and triacylglycerol concentrations were measured (Hitachi 747 autoanalyzer; Hitachi, Tokyo, Japan) (18).

### Statistics

The statistical package STATA (version 8.2; Stata Corp, College Station, TX) was used. The data were expressed as means  $\pm$  SEMs. Statistical significance was defined as a  $P$  value  $< 0.05$ ; otherwise, it was defined as nonsignificant.

The weighted "svy" or "robust" commands were used to account for the probability sampling weight, complex survey design, and stratification (34) in NAHSIT. The differences between 2 continuous variables were compared by unpaired  $t$  tests. The differences between 2 categorical variables were compared by chi-square tests. The differences between 2 nonnormally distributed variables (Framingham risk score and dietary intakes of cholesterol, sodium, and fruit) were compared by using nonparametric median tests. Linear regression analysis was used to test for the association of demographic and lifestyle variables, other than those used to estimate Framingham risk scores, with the Framingham risk score. Logistic regression analysis was used to test for the association of demographic and lifestyle variables with heart disease. Data were analyzed separately for men and women when there was a significant interaction between sex and the independent variables. Trend tests (18) for alcohol drinking status were also performed.

Note that a confounder is defined as a factor associated with both exposure (betel-quid use in this case) and outcome (Framingham risk score or heart disease in this case) (35). Abdominal obesity, alcohol drinking, and dietary fruit intake are all associated with both betel-quid use (18) and the Framingham risk score (5) and, therefore, are confounders to be adjusted in linear regression analyses. In contrast, variables of the Framingham risk score (sex, age, hypertension, DM, smoking, and concentrations of serum total cholesterol and HDL cholesterol) (33), abdominal obesity, alcohol drinking, and dietary fruit intake are all associated with both betel-quid use (18) and heart disease (5) and, therefore, are confounders to be adjusted in logistic regression analyses.

**TABLE 1**  
Demographic characteristics of NAHSIT (Nutrition and Health Survey in Taiwan) participants who did or did not use betel quid, by sex<sup>1</sup>

Betel-quid use	Men		Women		P <sup>2</sup>
	Betel-quid use (n = 277)	No betel-quid use (n = 619)	Betel-quid use (n = 79)	No betel-quid use (n = 957)	
Age (y)	36 ± 0.8 <sup>3</sup>	39 ± 0.6	34 ± 5	38 ± 0.4	NS/0.007
Smoking (pack-years) <sup>4</sup>	12 ± 1	5.4 ± 0.4 <sup>5</sup>	1.6 ± 0.8	0.1 ± 0.04	< 0.001/—
Alcohol drinking (drink-years)	40 ± 10	10 ± 3	18 ± 10	0.1 ± 0.02	< 0.001/0.01
Alcohol drinking status (%) <sup>6</sup>					< 0.001/< 0.001
Nil	23	54	30	88	
Moderate	32	36	38	11	
Heavy	45	10	32	1	
Framingham risk score (%) <sup>7,8</sup>	4 (4)	2 (5)	2 (1)	1 (1)	< 0.001/0.01
Heart disease (%)	1.5	3.5	3.2	2.3	NS/NS
Abdominal obesity (%)	9.2	10.9	16	16.4	0.03/NS
Diabetes mellitus (%)	3.8	3.7	2	4	NS/NS
Hypertension (%) <sup>4</sup>	22	26	39	16 <sup>9</sup>	NS/—
Metabolic syndrome (%)	11	9	6.7	9.8	NS/NS
Cholesterol (mg/dL)	192 ± 4	193 ± 3	186 ± 8	186 ± 3	0.01/NS
Triacylglycerol (mg/dL)	145 ± 9	120 ± 9	107 ± 10	94 ± 5	< 0.001/0.001
HDL cholesterol (mg/dL)	55 ± 1	54 ± 2	66 ± 4	61 ± 1	< 0.001/NS
Carbohydrate intake (% of energy)	52 ± 2	54 ± 1	45 ± 5	52 ± 2	NS/NS
Fat intake (% of energy)	29 ± 1	28 ± 1	36 ± 1	32 ± 1	0.004/NS
Cholesterol intake (g/d) <sup>8</sup>	0.27 (0.34)	0.28 (0.3)	0.27 (0.5)	0.2 (0.25)	0.001/NS
Protein intake (% of energy)	15 ± 0.8	16 ± 0.2	17 ± 1	16 ± 0.4	NS/NS
Sodium intake (g/d) <sup>8</sup>	2.8 (2.6)	2.9 (2.9)	2 (0.3)	2.7 (2.3)	NS/NS
Vegetable intake (times/wk)	25 ± 2	27 ± 1	28 ± 3	28 ± 2	0.01/NS
Fruit intake (times/wk) <sup>8</sup>	3 (6)	6 (6)	4 (7)	7 (5)	0.01/0.01

<sup>1</sup> Fasting morning blood samples were drawn and centrifuged on site. Serum was stored at -70 °C until analyzed within a month for total cholesterol, triacylglycerol, and HDL-cholesterol concentrations with the use of a Hitachi 747 autoanalyzer (Hitachi, Tokyo, Japan). The differences between continuous variables (except Framingham risk score and dietary intakes of cholesterol, sodium, and fruit) were tested by using unpaired *t* tests. The differences between categorical variables were tested by using chi-square tests.

<sup>2</sup> Men compared with women/betel-quid use yes compared with no.

<sup>3</sup>  $\bar{x} \pm$  SEM (all such values).

<sup>4</sup> *P* < 0.05 for the interaction between sex and betel-quid use.

<sup>5</sup> *P* < 0.001.

<sup>6</sup> Classified as nil, moderate ( $\leq 1$  drink/d for women) and  $\leq 2$  drinks/d for men), or heavy ( $> 1$  drink/d for women and  $> 2$  drinks/d for men).

<sup>7</sup> Calculated only for NAHSIT participants without heart disease.

<sup>8</sup> All values are medians (interquartile range, ie, the difference between the third and first quartiles in parentheses) and were compared by using nonparametric median tests because of nonnormal distribution.

<sup>9</sup> Significantly different from betel-quid use when the sex  $\times$  betel-quid use interaction was significant: <sup>5</sup>*P* < 0.001, <sup>9</sup>*P* < 0.01.

It requires  $\geq 10$  cases (of heart disease in this instance) for each independent variable in a logistic regression model (36). Moreover, subgroup analyses should only be performed when statistical tests of interaction are significant (37). Thus, to assess the independent effect of betel-quid use on heart disease, we analyzed all participants (*n* = 1932) with an interaction term (sex by betel-quid use) in which the number of outcomes (heart disease) was 127 and the number of independent variables was 11.

**RESULTS**

**Demographic characteristics of NAHSIT enrollees, by participation**

The recruitment rate was 49.4% (1932/3910) of those approached. There was a lower percentage of men in the participants' subgroup than in the nonparticipants' subgroup (48% compared with 54%; *P* = 0.005). Moreover, the participants were older than the nonparticipants (39 ± 0.4 compared with 37 ± 0.4 y; *P* = 0.002).

In contrast, there were no differences in betel-quid use, smoking, alcohol drinking, and heart disease between the participants and the nonparticipants. Note that the Framingham risk score, obesity, hypertension, DM, dietary intakes, and concentrations of serum cholesterol, triacylglycerol and HDL cholesterol could not be compared between the participants and nonparticipants because most of the nonparticipants did not provide these data.

**Prevalence of betel-quid use and heart disease in NAHSIT participants, by sex and age**

The overall (weighted) prevalence of betel-quid use was 16.9%, which was higher in men than in women (31% versus 2.4%, *P* < 0.001). In contrast, the crude prevalence of betel-quid use was 30.9% (277/896) and 7.6% (79/1036) in men and women (Table 1), respectively. The overall (weighted) prevalence of heart disease was 2.8%, which was not significantly different between men and women (3.3% compared with 2.3%; *P* = 0.12). In contrast, the crude prevalence of heart disease was 5.2%

1075  
R



**TABLE 2**  
Demographic characteristics of NAHSIT (Nutrition and Health Survey in Taiwan) participants with and without prevalent heart disease<sup>1</sup>

Heart disease	Heart disease		P <sup>2</sup>
	Yes (n = 47 M, 80 F)	No (n = 849 M, 956 F)	
Age (y)	53 ± 1 <sup>3</sup>	38 ± 0.4	< 0.001
Smoking (pack-years)	6 ± 2.5	3.8 ± 0.3	NS
Alcohol drinking (drink-years)	9.6 ± 7	7 ± 2	NS
Alcohol drinking status <sup>4</sup>			NS
Nil	67	65	
Moderate	27	27	
Heavy	6	8	
Betel-quin use (%)	10.8	17.3	NS
Abdominal obesity (%)	40	13	< 0.001
Diabetes mellitus (%)	17.7	3.6	0.002
Hypertension (%) <sup>5</sup>			
Men	53	24	0.02
Women	71	15	< 0.001
Metabolic syndrome (%)	27	9.3	< 0.001
Total cholesterol (mg/dL)	202 ± 5	189 ± 2	0.03
Triacylglycerol (mg/dL)	128 ± 12	110 ± 4	0.03
HDL cholesterol (mg/dL)	54 ± 3	58 ± 1	NS
Carbohydrate intake (% of energy)	55 ± 2	53 ± 1	NS
Fat intake (% of energy)	27 ± 2	30 ± 1	NS
Cholesterol intake (g/d) <sup>6</sup>	0.17 (0.27)	0.25 (0.31)	NS
Protein intake (% of energy)	18 ± 1	16 ± 4	NS
Sodium intake (g/d) <sup>6</sup>	2.4 (2.4)	2.8 (2.6)	NS
Vegetable intake (times/wk)	25 ± 1	27 ± 2	NS
Fruit intake (times/wk) <sup>6</sup>	5.5 (8)	3.5 (9)	NS

<sup>1</sup> Fasting morning blood samples were drawn and centrifuged on site. Serum was stored at -70 °C until analyzed within a month for total cholesterol, triacylglycerol, and HDL-cholesterol concentrations with the use of a Hitachi 747 autoanalyzer (Hitachi, Tokyo, Japan).

<sup>2</sup> The differences between continuous variables (except Framingham risk score and dietary intakes of cholesterol, sodium, and fruit) were tested by using unpaired *t* tests. The differences between categorical variables were tested by using chi-square tests.

<sup>3</sup>  $\bar{x} \pm \text{SEM}$  (all such values).

<sup>4</sup> Classified as nil, moderate ( $\leq 1$  drink/d for women and  $\leq 2$  drinks/d for men), and heavy ( $> 1$  drink/d for women and  $> 2$  drinks/d for men).

<sup>5</sup> The data were reported separately for men and women when there was a significant interaction between sex and heart disease.

<sup>6</sup> All values are medians (interquartile range, ie, the difference between the third and first quartiles, in parentheses) and were compared by using nonparametric median tests because of nonnormal distribution.

(47/896) and 7.7% (80/1036) in the men and women, respectively (Table 2). The (weighted) prevalence of heart disease was 1.8% in betel-quin users. In contrast, the crude prevalence of heart disease in betel-quin users was 7.3% (26/356). Additionally, among betel-quin users, there were 10 men and 16 women. Moreover, the prevalence of betel-quin use decreased ( $P = 0.01$ ), whereas the prevalence of heart disease increased ( $P = 0.001$ ) with increasing age in both sexes (data not shown).

#### Demographic characteristics of NAHSIT participants, by sex and betel-quin use

As shown in Table 1, smoking, alcohol drinking, Framingham risk score, serum total cholesterol and triacylglycerol concentrations, and dietary cholesterol intake were higher in men than in women. Conversely, the prevalence of abdominal obesity, serum HDL-cholesterol concentrations, and dietary intakes of fat, vegetable, and fruit were lower in men than in women. In contrast, there were no differences in age, DM, and the metabolic syndrome between men and women.

Betel-quin users were younger than the nonusers. Additionally, both male and female betel-quin users drank more, had a higher Framingham risk score and serum triacylglycerol concentration, and had a lower intake of dietary fruit intake than did the nonusers. Interestingly, male but not female betel-quin users smoked more than did the nonusers. In contrast, female but not male betel-quin users had a higher prevalence of hypertension than did the nonusers. Conversely, there were no differences in serum concentrations of total cholesterol and HDL cholesterol, dietary intakes other than fruit, and the prevalence of heart disease, abdominal obesity, DM, and the metabolic syndrome between the betel-quin users and the nonusers in either sex.

#### Demographic characteristics of NAHSIT participants with and without heart disease

As shown in Table 2, the participants with heart disease were older, had higher serum total cholesterol and triacylglycerol concentrations, and had a higher prevalence rate of abdominal obesity, DM, hypertension, and the metabolic syndrome than did those without heart disease. In contrast, there were no differences in betel-quin use or in any of the dietary intakes between participants with and without heart disease.

#### Association of the demographic and lifestyle factors with the Framingham risk score in NAHSIT participants in a linear regression analysis

As shown in Table 3, betel-quin use (yes or no) was positively associated with the Framingham risk score, whereas the daily rate of betel-quin use was positively associated with the Framingham risk score only in participants without heart disease. Note that there were no interactions between sex, heart disease, and betel-quin use.

In the multivariate analysis, the effect of betel-quin use was adjusted for abdominal obesity, dietary fruit intake, and alcohol drinking. We found that betel-quin use [yes or no:  $1.76 \pm 0.5$  (coefficient  $\pm$  SEM);  $r = 0.33$ ,  $P = 0.004$ ], but not the daily rate of betel-quin use ( $0.25 \pm 0.13$ ;  $r = 0.31$ ,  $P = 0.08$ ) was independently and positively associated with the Framingham risk score. However, the daily rate of betel-quin use was independently and positively associated with the Framingham risk score if we excluded abdominal obesity from the adjustment factors ( $0.46 \pm 0.14$ ;  $r = 0.1$ ,  $P = 0.007$ ). Note that there were no interactions between sex, heart disease, and betel-quin use in the above multivariate analyses.

As shown in Table 3, abdominal obesity was positively associated with the Framingham risk score, but dietary intakes of carbohydrate and fat were associated positively and negatively with the Framingham risk score, respectively, only in women. In contrast, alcohol drinking was positively associated with the Framingham risk score in participants with heart disease, whereas alcohol drinking was associated positively and negatively with the Framingham risk score in men and women, respectively, in participants without heart disease. However, alcohol drinking status (nil, moderate, or heavy) was not associated with the Framingham risk score.

#### Association of betel-quin use with prevalent heart disease in a multiple logistic regression analysis

The effect of betel-quin use was adjusted for sex, age, abdominal obesity, concentrations of serum total cholesterol and HDL



1076  
8

TABLE 3

Association of the demographic and lifestyle factors with Framingham risk scores in NAHSIT (Nutrition and Health Survey in Taiwan) participants<sup>1</sup>

	Framingham risk score	
	Coefficient (95% CI)	P
Betel-quid use (yes or no)	1.5 (0.7, 2.3)	0.001
Daily rate of betel-quid use (10 times/d), heart disease present <sup>2</sup>	-1.8 (-4.3, 0.7)	NS
Daily rate of betel-quid use (10 times/d), heart disease absent <sup>2</sup>	0.54 (0.28, 0.8)	0.001
Abdominal obesity (yes or no)	5.2 (3.6, 6.8)	< 0.001
Alcohol drinking (drink-years), heart disease present <sup>3</sup>	0.01 (0.008, 0.013)	0.001
Alcohol drinking (drink-years), heart disease absent <sup>3</sup>		
Men	0.009 (0.002, 0.02)	0.02
Women	-0.008 (-0.02, -0.0001)	0.047
Alcohol drinking status <sup>3,4</sup>	-0.01 (-0.14, 0.12)	NS <sup>5</sup>
Carbohydrate intake (% of energy) <sup>6</sup>		
Men	-1.86 (-6, 2.5)	NS
Women	3.3 (2, 4.6)	< 0.001
Fat intake (% of energy) <sup>6</sup>		
Men	2.5 (-2, 6)	NS
Women	-2.9 (-3.7, -2)	< 0.001
Cholesterol intake (g/d)	-0.19 (-0.95, 0.6)	NS
Protein intake (% of energy)	-0.48 (-5.7, 4.7)	NS
Sodium intake (g/d)	0.006 (-0.06, 0.07)	NS
Vegetable intake (times/d)	-0.005 (-0.03, 0.02)	NS
Fruit intake (times/d)	-0.02 (-0.06, 0.02)	NS

<sup>1</sup> n = 1932 (n = 47 men and 80 women with heart disease; n = 849 men and 956 women without heart disease). Linear regression analysis was used to assess the association between independent (demographic and lifestyle factors) and dependent (Framingham risk score) factors.

<sup>2</sup> The data were reported separately for participants with and without prevalent heart disease for the independent variable when there was a significant interaction between heart disease and that independent variable.

<sup>3</sup> The data were reported separately for men and women with and without prevalent heart disease for the independent variable when there was a significant interaction between sex, heart disease, and that independent variable.

<sup>4</sup> Classified as nil, moderate ( $\leq 1$  drink/d for women and  $\leq 2$  drinks/d for men), and heavy ( $> 1$  drink/d for women and  $> 2$  drinks/d for men).

<sup>5</sup> P for linear trend.

<sup>6</sup> The data were reported separately for men and women for the independent variable when there was a significant interaction between sex and that independent variable.

cholesterol, hypertension, DM, smoking, alcohol drinking, and dietary fruit intake. As shown in Table 4, betel-quid use was not associated with prevalent heart disease when analyzed as a categorical variable (yes or no) in either sex. However, betel-quid

use was independently and positively associated with prevalent heart disease when analyzed as a continuous variable only in women (OR associated with a betel-quid consumption rate of 10 times/d: 1.37; 95% CI: 1.1, 1.6; P = 0.003). Note that a betel-quid consumption rate of 10 times/d was chosen because it was the third quartile of betel-quid consumption in betel-quid users. There were no interactions between age and betel-quid use in the above analyses.

TABLE 4

Association of betel-quid use with prevalent heart disease in multiple logistic regression analysis in NAHSIT (Nutrition and Health Survey in Taiwan) participants<sup>1</sup>

Betel-quid use	Odds ratio (95% CI)	P
Yes or no <sup>2</sup>		
Men	0.2 (0.02, 2.4)	NS
Women	2.6 (0.7, 10)	NS
Daily rate, 10 times/d <sup>3</sup>		
Men	0.5 (0.14, 1.9)	NS
Women	1.37 (1.1, 1.6)	0.003

<sup>1</sup> n = 1932 (n = 896 men and n = 1036 women). Multiple logistic regression analysis was used to assess the effect of betel-quid use on prevalent heart disease after adjustment for sex, age, abdominal obesity, concentrations of serum total cholesterol and HDL cholesterol, hypertension, diabetes mellitus, smoking, alcohol drinking, and dietary fruit intake.

<sup>2</sup> P = 0.03 for interaction between sex and betel-quid use (yes or no).

<sup>3</sup> P = 0.01 for interaction between sex and the daily rate of betel-quid use. A daily consumption rate of (10 times/d) was chosen because it was the third quartile of betel-quid consumption in betel-quid users.

DISCUSSION

We found that betel-quid use is associated with heart disease and the Framingham risk score in women. This finding extends our previous finding that betel-quid use is associated with the metabolic syndrome in adults (18). In view of the large world population that uses betel quid (13) and the effect of heart disease on global health (1), these findings have important implications.

In this study, the prevalence of heart disease was not significantly different between sexes. However, there were many imbalances of heart disease risk factors between the sexes. Thus, data were analyzed separately for men and women whenever necessary.

In NAHSIT participants without heart disease, the daily rate of betel-quid use was independently associated with the Framingham risk score only after abdominal obesity was excluded from

1077  
6

the adjustment factors. Thus, abdominal obesity may be an intermediate variable along the causal pathway between betel-quinid use and the Framingham risk score, not needing to be adjusted for (35).

Alcohol drinking was associated positively with the Framingham risk score in participants with heart disease. In contrast, alcohol drinking was associated positively and negatively with the Framingham risk score in men and women, respectively, in participants without heart disease. However, alcohol drinking was associated negatively with the Framingham risk score in women regardless of heart disease ( $P = 0.015$ ), but not in men ( $P = 0.2$ ), only after adjustment for serum creatinine concentration—a heart disease risk factor (38) (data not shown). This observation is different from the notion that moderate, but not heavy, alcohol drinking, is negatively associated with the risk of coronary heart disease (39). However, this observation is consistent with that of a recent study, which showed that alcohol drinking is linearly and negatively associated with the risk of coronary heart disease in women (4).

In contrast, alcohol drinking was not associated with prevalent heart disease. This observation is consistent with the finding of an international case-control study (including Chinese participants), which showed that alcohol drinking is not associated with acute myocardial infarction after adjustment for multiple risk factors (40).

In the univariate analysis, the prevalence of heart disease was not different between betel-quinid users and nonusers in men and women, despite the imbalances of some of the heart disease risk factors with sex. Moreover, the prevalence of betel-quinid use decreased with age, whereas the prevalence of heart disease increased with age. Thus, the role of betel-quinid use in heart disease was analyzed by multiple logistic regression analysis after adjustment for the multiple heart disease risk factors assessed, and we found that the daily rate of betel-quinid use, but not betel-quinid use (yes or no), was independently associated with prevalent heart disease in women.

The sex-specific effect of betel-quinid use was also observed in a previous study, which showed that betel-quinid use was associated with hyperglycemia only in women (17), although a recent large community-based study showed that betel-quinid use was associated with hyperglycemia in both sexes (16). Similarly, transient hyperglycemia in DM increases the glomerular filtration rate only in women (41). Interestingly, DM and hypertension are greater risk factors for heart disease in women than in men (42). Moreover, women have a higher resting heart rate than do men (42), a heart disease risk factor (43), which is further increased by betel-quinid use (44).

There are several possible mechanisms for the association between betel-quinid use and heart disease. The first 2 mechanisms relate to the fact that betel quid contains substances with both sympathetic and parasympathetic activities (44). First, betel-quinid activates the sympathetic nervous system (44), which is a heart disease risk factor (45) associated with obesity (46), hypertension (47), and the metabolic syndrome (48)—the cardinal heart disease risk factors (2, 3). Other adverse cardiovascular effects of sympathetic activation include reduced vascular conductance, impaired baroreflex buffering, and decreased heart responsiveness to  $\beta$ -adrenergic stimulation, etc (49).

Second, there is a harmonious vagosympathetic interaction in normal cardiac autonomic regulation, whereas a high activity of the heart from both autonomic systems may be arrhythmogenic

(50). Moreover, *Piper betle* inflorescence extract, chewed in combination with *Areca catechu* nut in betel quids, also activates both cardiac autonomic systems in rats (51).

Finally, betel-quinid use is associated with obesity, hypertension, hypertriglycerolemia, DM, and the metabolic syndrome (16–18)—the heart disease risk factors (2, 3). Note that although betel-quinid use was not associated with abdominal obesity or the metabolic syndrome in the univariate analysis, the daily rate of betel-quinid use was associated with abdominal obesity and metabolic syndrome in multivariate analysis both in the present study (data not shown) and our previous study (18).

This study and all secondary analyses had several limitations (52). First, being a secondary analysis, sampling and measurement issues were inevitable (52). However, NAHSIT was a nationally representative study, whereas there was no selection bias associated with participation other than sex and age, which were adjusted for in the multivariate analyses. Moreover, all relevant measurements were made with standard methods. Second, disease (heart disease in this case) was defined by the participant's recall and not by using gold-standard diagnoses. Third, because this was a cross-sectional study, causality could not be established. Finally, it is not known whether the subjects changed their diets after having been diagnosed with heart disease. However, this event is unlikely because betel-quinid use was not a known risk factor for heart disease in 1993–1996. We conclude that, although men used more betel-quinid chews than women, betel-quinid use is independently associated with heart disease only in women. 

The assistance provided by Academia Sinica with the data distribution was greatly appreciated.

The authors' responsibilities were as follows—J-YG: design and analysis of the study; H-CC: data collection and analysis; J-FT: statistical analyses; L-YC: fund raising and collaborative analysis of the study. All authors reviewed and approved the final manuscript. None of the authors had a conflict of interest.

## REFERENCES

1. Yach D, Hawkes C, Gould CL, Hofman KJ. The global burden of chronic diseases: overcoming impediments to prevention and control. *JAMA* 2004;291:2616–22.
2. Lawes CM, Rodgers A, Bennett DA, et al. Blood pressure and cardiovascular disease in the Asia Pacific region. *J Hypertens* 2003;21:707–16.
3. Anonymous. Executive Summary of The Third Report of The National Cholesterol Education Program (NCEP) Expert Panel on Detection, Evaluation, and Treatment of High Blood Cholesterol In Adults (Adult Treatment Panel III). *JAMA* 2001;285:2486–97.
4. Tolstrup J, Jensen MK, Tjonneland A, Overvad K, Mukamal KJ, Gronbaek M. Prospective study of alcohol drinking patterns and coronary heart disease in women and men. *BMJ* 2006;332:1244–8.
5. Lichtenstein AH, Appel LJ, Brands M, et al. Diet and lifestyle recommendations revision 2006: a scientific statement from the American Heart Association Nutrition Committee. *Circulation* 2006;114:82–96.
6. Lutz W, Sanderson W, Scherbov S. The end of world population growth. *Nature* 2001;412:543–5.
7. Mascie-Taylor CG, Karim E. The burden of chronic disease. *Science* 2003;302:1921–2.
8. Chobanian AV, Bakris GL, Black HR, et al. The Seventh Report of the Joint National Committee on Prevention, Detection, Evaluation, and Treatment of High Blood Pressure: the JNC 7 report. *JAMA* 2003;289:2560–72.
9. Bonow RO, Gheorghide M. The diabetes epidemic: a national and global crisis. *Am J Med* 2004;116(suppl):2S–10S.
10. Chan JC, Ng MC, Critchley JA, Lee SC, Cockram CS. Diabetes mellitus—a special medical challenge from a Chinese perspective. *Diabetes Res Clin Pract* 2001;54(suppl):S19–27.



1078

11. Ginsberg HN. New perspectives on atherogenesis: role of abnormal triglyceride-rich lipoprotein metabolism. *Circulation* 2002;106:2137-42.
12. Lei D, Chan CP, Wang YJ, et al. Antioxidative and antiplatelet effects of aqueous inflorescence *Piper betle* extract. *J Agric Food Chem* 2003;51:2083-8.
13. Boucher BJ, Mannan N. Metabolic effects of the consumption of *Areca catechu*. *Addict Biol* 2002;7:103-10.
14. Tsai JF, Jeng JE, Chuang LY, et al. Habitual betel quid chewing and risk for hepatocellular carcinoma complicating cirrhosis. *Medicine (Baltimore)* 2004;83:176-87.
15. IARC Working Group on the Evaluation of Carcinogenic Risks to Humans. Betel-quid and areca-nut chewing and some areca-nut derived nitrosamines. *IARC Monogr Eval Carcinog Risks Hum* 2004;85:1-334.
16. Yen AM, Chiu YH, Chen LS, et al. A population-based study of the association between betel-quid chewing and the metabolic syndrome in men. *Am J Clin Nutr* 2006;83:1153-60.
17. Mannan N, Boucher BJ, Evans SJ. Increased waist size and weight in relation to consumption of *Areca catechu* (betel-nut); a risk factor for increased glycaemia in Asians in east London. *Br J Nutr* 2000;83:267-75.
18. Guh JY, Chuang LY, Chen HC. Betel-quid use is associated with the risk of the metabolic syndrome in adults. *Am J Clin Nutr* 2006;83:1313-20.
19. Hung DZ, Deng JF. Acute myocardial infarction temporally related to betel nut chewing. *Vet Hum Toxicol* 1998;40:25-8.
20. Deng JF, Ger J, Tsai WJ, Kao WF, Yang CC. Acute toxicities of betel nut: rare but probably overlooked events. *J Toxicol Clin Toxicol* 2001;39:355-60.
21. Chiang WT, Yang CC, Deng JF, Bullard M. Cardiac arrhythmia and betel nut chewing—is there a causal effect? *Vet Hum Toxicol* 1998;40:287-9.
22. Pan WH, Yeh WT, Chang HY, Hwu CM, Ho LT. Prevalence and awareness of diabetes and mean fasting glucose by age, sex, and region: results from the Nutrition and Health Survey in Taiwan, 1993-1996. *Diabet Med* 2003;20:182-5.
23. Pan WH, Kao MD, Tzeng MS, et al. Nutrition and health survey in Taiwan (NAHSIT) 1993-1996: design, contents, and operations. *Nutr Sci J* 1999;24:1-10.
24. Huang SL, Lin KC, Pan WH. Dietary factors associated with physician-diagnosed asthma and allergic rhinitis in teenagers: analyses of the first Nutrition and Health Survey in Taiwan. *Clin Exp Allergy* 2001;31:259-64.
25. Pan WH, Chang YH, Chen JY, Wu SJ, Tzeng MS, Kao MD. Nutrition and Health Survey in Taiwan (NAHSIT) 1993-1996: dietary nutrient intakes assessed by 24-hour recall. *Nutr Sci J* 1999;24:11-40.
26. Department of Health. Nutrient composition data bank for foods of Taiwan area. Taipei, Taiwan: Department of Health, Republic of China, 1998.
27. Lin YC, Yen LL, Chen SY, et al. Prevalence of overweight and obesity and its associated factors: findings from National Nutrition and Health Survey in Taiwan, 1993-1996. *Prev Med* 2003;37:233-41.
28. Pan WH, Yeh WT, Hwu CM, Ho LT. Undiagnosed diabetes mellitus in Taiwanese subjects with impaired fasting glycemia: impact of female sex, central obesity, and short stature. *Chin J Physiol* 2001;44:44-51.
29. Pan WH, Flegal KM, Chang HY, Yeh WT, Yeh CJ, Lee WC. Body mass index and obesity-related metabolic disorders in Taiwanese and US whites and blacks: implications for definitions of overweight and obesity for Asians. *Am J Clin Nutr* 2004;79:31-9.
30. Tan CE, Ma S, Wai D, Chew SK, Tai ES. Can we apply the National Cholesterol Education Program Adult Treatment Panel definition of the metabolic syndrome to Asians? *Diabetes Care* 2004;27:1182-6.
31. Alberti KG, Zimmet P, Shaw J. The metabolic syndrome—a new worldwide definition. *Lancet* 2005;366:1059-62.
32. Eckel RH, Grundy SM, Zimmet PZ. The metabolic syndrome. *Lancet* 2005;365:1415-28.
33. Wilson PW, D'Agostino RB, Levy D, Belanger AM, Silbershatz H, Kannel WB. Prediction of coronary heart disease using risk factor categories. *Circulation* 1998;97:1837-47.
34. LaVange LM, Koch GG, Schwartz TA. Applying sample survey methods to clinical trials data. *Stat Med* 2001;20:2609-23.
35. McNamee R. Regression modelling and other methods to control confounding. *Occup Environ Med* 2005;62:500-6.
36. Katz MH. Multivariable analysis: a primer for readers of medical research. *Ann Intern Med* 2003;138:644-50.
37. Schulz KF, Grimes DA. Multiplicity in randomised trials II: subgroup and interim analyses. *Lancet* 2005;365:1657-61.
38. Go AS, Chertow GM, Fan D, McCulloch CE, Hsu CY. Chronic kidney disease and the risks of death, cardiovascular events, and hospitalization. *N Engl J Med* 2004;351:1296-305.
39. Goldberg DJ, Mosca L, Piano MR, Fisher EA. AHA Science Advisory: wine and your heart: a science advisory for healthcare professionals from the Nutrition Committee, Council on Epidemiology and Prevention, and Council on Cardiovascular Nursing of the American Heart Association. *Circulation* 2001;103:472-5.
40. Yusuf S, Hawken S, Ounpuu S, et al. Effect of potentially modifiable risk factors associated with myocardial infarction in 52 countries (the INTERHEART study): case-control study. *Lancet* 2004;364:937-52.
41. Cherney DZ, Sochett EB, Miller JA. Gender differences in renal responses to hyperglycemia and angiotensin-converting enzyme inhibition in diabetes. *Kidney Int* 2005;68:1722-8.
42. Regitz-Zagrosek V. Therapeutic implications of the gender-specific aspects of cardiovascular disease. *Nat Rev Drug Discov* 2006;5:425-38.
43. Palatini P, Julius S. Elevated heart rate: a major risk factor for cardiovascular disease. *Clin Exp Hypertens* 2004;26:637-44.
44. Chu NS. Neurological aspects of areca and betel chewing. *Addict Biol* 2002;7:111-4.
45. Phillips JK. Pathogenesis of hypertension in renal failure: role of the sympathetic nervous system and renal afferents. *Clin Exp Pharmacol Physiol* 2005;32:415-8.
46. Landsberg L. Feast or famine: the sympathetic nervous system response to nutrient intake. *Cell Mol Neurobiol* 2006;26:497-508.
47. Guyenet PG. The sympathetic control of blood pressure. *Nat Rev Neurosci* 2006;7:335-46.
48. Kaaja RJ, Pohjonen-Alho MK. Insulin resistance and sympathetic overactivity in women. *J Hypertens* 2006;24:131-41.
49. Seals DR, Dineno FA. Collateral damage: cardiovascular consequences of chronic sympathetic activation with human aging. *Am J Physiol Heart Circ Physiol* 2004;287:H1895-905.
50. Paton JF, Boscan P, Pickering AE, Nalivaiko E. The yin and yang of cardiac autonomic control: vago-sympathetic interactions revisited. *Brain Res Brain Res Rev* 2005;49:555-65.
51. Chen SJ, Wu BN, Yeh JL, Lo YC, Chen IS, Chen JJ. C-fiber-evoked autonomic cardiovascular effects after injection of *Piper betle* inflorescence extracts. *J Ethnopharmacol* 1995;45:183-8.
52. Clarke SP, Cossette S. Secondary analysis: theoretical, methodological, and practical considerations. *Can J Nurs Res* 2000;32:109-29.



# A prospective community-population-registry-based cohort study of the association between betel-quid chewing and cardiovascular disease in men in Taiwan (KCIS no. 19)<sup>1-3</sup>

Amy Ming-Fang Yen, Li-Sheng Chen, Yueh-Hsia Chiu, Barbara J Boucher, and Tony Hsiu-Hsi Chen

## ABSTRACT

**Background:** Betel-quid chewing, a recognized risk factor for oral cancer, was shown to be a contributory cause of metabolic syndrome in humans, which implies a greater likelihood of developing cardiovascular disease (CVD) among those with the betel habit.

**Objective:** This study investigated the effect of betel chewing on the risk of developing overt CVD.

**Design:** We used the prospective cohort data derived from a community-population-registry-based integrated screening program to quantify the effect of betel-quid chewing on the incidence of newly diagnosed CVD by classifying the study population into either exposed or nonexposed groups according to chewing status at baseline. We then followed the group free of CVD at recruitment for 2.72 y (SD = 1.52 y) to learn of new cardiovascular events. Proportional hazards regression modeling was used to estimate the magnitude of the effect of betel-quid chewing on CVD.

**Results:** After control for age and education level, ever chewers had a 23% (95% CI: 11%, 37%) greater risk of developing CVD than did never chewers; ever chewers were still at greater risk of developing CVD by 24% (95% CI: 11%, 39%) after further adjustment for age, education, and other significant confounders. Significant dose-response relations were found for betel-quid chewing ( $P < 0.05$ , trend test) after adjustment for other significant variables.

**Conclusion:** The habit of chewing betel nut was shown to have independent dose effects to predict increases in the risk of CVD in men, with the use of a prospective community-population-registry-based cohort study. *Am J Clin Nutr* 2008;87:70-8.

**KEY WORDS** Cardiovascular disease, betel quid, *Areca catechu*, chewing, dose-response effect, community-based integrated screening, prevalence, risk factors, humans, men

## INTRODUCTION

The habit of betel-quid chewing is common in many Asian countries such as India and Taiwan and wherever betel-chewing communities migrate. The betel habit is a recognized risk factor for oral cancer (1) and appears to be a contributory cause for developing type 2 diabetes mellitus (T2DM), central obesity, and hyperglycemia in animal experiments (2) and the metabolic syndrome (MetS) in recent studies in humans (3-8). The findings on MetS imply that there should be an increased likelihood of developing cardiovascular disease (CVD) among those with the betel habit because the main components commonly included in the definition of MetS [according to the National Cholesterol

Education Program/Adult Treatment (Panel III (9))] are strongly related to the subsequent occurrence of CVD. Possible underlying biological mechanisms that could account for the association of betel chewing with CVD include the known increases in circulating catecholamines and enhanced activity of both sympathetic and parasympathetic components of the autonomic nervous system in humans (10-12). The dose-effect increases in inflammatory markers pertaining to CVD risk, such as matrix metalloproteinase 9 (MMP9) and C-reactive protein, have also been found in association with the betel habit (13).

Despite these findings direct evidence is lacking to show the association of betel-quid chewing with the development of CVD in human beings. Although sporadic case reports suggest this possibility (14, 15), there are no studies of any population-based cohort with large numbers of subjects or with continued follow-up and no prospective studies on this topic. Recently initiated community-based studies, such as the Keelung Community-based Integrated Screening (KCIS) program (16), provide an opportunity to assess the effect of the betel-quid chewing habit prospectively with data collected at baseline on occurrence rates of newly diagnosed CVD during follow-up in the cohort free of CVD at baseline screening. The aim of this study was, therefore, to determine whether there was an effect of betel chewing on the risk of developing overt CVD (confirmed CVD or death from CVD) in a large prospective and community-population-registry-based cohort.

## SUBJECTS AND METHODS

### Study population

Subjects in the current study were derived from a target population of all 185 596 inhabitants aged 20-79 y in Keelung, the

<sup>1</sup> From the Institute of Preventive Medicine (AM-FY, L-SC, and TH-HC) and Division of Biostatistics (Y-HC and TH-HC) College of Public Health, National Taiwan University, Taipei, Taiwan; Taiwan Association of Medical Screening, Taipei, Taiwan (AM-FY, L-SC, Y-HC, and TH-HC); Center for Diabetes & Metabolic Medicine, Queen Mary School of Medicine & Dentistry, Royal London Hospital, London, United Kingdom (BJB).

<sup>2</sup> Supported by the National Science Council (NSC 91-2320-B002-171; NSC 91-2320-B002-172).

<sup>3</sup> Address reprint requests to TH-H Chen, Division of Biostatistics, Institute of Preventive Medicine, College of Public Health, National Taiwan University, Room 532, No. 17, Hsuehshow Road, Taipei, Taiwan. E-mail: chenlin@ntu.edu.tw.

Received December 27, 2006.

Accepted for publication August 28, 2007.

1080

northernmost city of Taiwan. The inhabitants were invited to take part in a screening program directed at common cancers and certain chronic diseases and their risk factors, within the KCIS program (16). Details of the original study design, implementation, follow-up, and preliminary results of the KCIS study are described in full elsewhere (16, 17). The KCIS program offers a continuing evidence-based screening program for 5 neoplastic diseases and 3 nonneoplastic diseases with interscreening intervals ranging between 1 and 5 y, depending on the particular disease. Thus, the KCIS program has been running annual recruitment screening between 1999 and 2004 with ongoing interval review of KCIS recruits as above. This program was approved by the local ethics committee of the Health Bureau of Keelung City, including the systems for the data linkage and for the maintenance of subjects' confidentiality. Written informed consent of each participant was obtained at recruitment in the program. It is a prospective cohort study with staggered entry times for participants in the KCIS program. In the current study,  $\approx 74\ 804$  KCIS screened participants, who had attended periodic face-to-face questionnaire interviews that correspond to the interscreening interval designed in the KCIS program at least once between 1999 and 2004, were eligible for inclusion in the present study. The coverage rate was 40% by the end of 2004. Because the KCIS program was designed to offer mass screening for many detectable cancers and chronic diseases, participants were enrolled from the Keelung population registry rather than by seeking volunteers by advertisement. Moreover, although the questionnaire interviews were performed by public health nurses and contained questions on exposure to betel-quin chewing and on other baseline variables, the participants were not aware of any hypothesis about the association between betel-quin chewing and CVD before the screening. Because the KCIS program has collected baseline information on the betel-quin chewing habit as well as including data on the factors widely recognized to be associated with increased CVD risk, our data offer a unique opportunity to elucidate the independent effect of betel chewing on the occurrence of chronic diseases. Indeed, the dose-related relations of betel-quin chewing to the risk of developing T2DM (5) and of developing the MetS (6) in the KCIS program could only be elucidated because of these features of this prospective study.

### Study design

Basically, it is a prospective study because exposure to betel-quin chewing was collected before the development of newly diagnosed CVD by following a normal cohort from which study subjects with previously diagnosed CVD at baseline were already excluded. The data used in the current subsidiary analysis about the assessment of the specific hypothesis were derived from a community- and population-registry-based integrated screening program that was designed to provide early detection of 5 major screen-detectable cancers and 3 chronic diseases by inviting residents from the population registry to participate between 1999 and 2004. However, the study design was, therefore, not tailored solely for examining the hypothesis: betel-quin chewing may lead to a higher risk of developing CVD, as seen in a conventional cohort study that sets up a specific exposure and follows subjects over time to ascertain the outcome of interest. Instead, we built up a cohort through a population-registry-based screening program. Because our screening program has

collected a constellation of demographic features, lifestyle factors (eg, smoking, alcohol consumption, and betel-quin chewing), biochemical markers, dietary habits, family history of major diseases, and personal disease history, the entire cohort has also provided a series of multiple outcomes, including not only 8 diseases covered within the screening program by rescreening but also other diseases (such as CVD) by following the initially CVD-free cohort over time. Both features offer an opportunity to assess the hypotheses: betel-quin chewing leads to higher risk of CVD, with or without adjustment for other confounding factors. We divided the entire normal cohort (of members free of CVD at entry to the screening program) into exposure (betel-quin chewer) and nonexposure (nonchewer) groups and ascertained incident CVD cases through the linkage of the entire cohort with the health insurance data for costs claimed by local hospitals in Keelung district. Each specific disease in these claims data was provided by physicians with a specific International Classification of Diseases (ICD) code when completing medical charts. Because the KCIS program is an organized screening program conducted by the Keelung City Bureau of Health, all participants with an abnormal finding on chronic diseases will be referred to clinics or local hospitals by public health nurses from the local health center, which can then determine the outcome on follow-up. In addition, the entire cohort was also linked with the Taiwan National Mortality Registry to ascertain CVD or non-CVD deaths.

Because the prevalence rate of betel-quin chewing is low (0.88%) in Taiwanese women compared with that in men (16.12%), we only included male subjects in our study ( $n = 28\ 344$ ). After excluding those without records on the habit of betel-quin chewing ( $n = 618$ ), 27 726 men were included. To enhance the validity of the examination of the prospective data for evidence of a causal relation between betel-quin chewing and CVD, the subjects with previously diagnosed CVD at recruitment ( $n = 5820$ ) were excluded from analyses. Thus, complete datasets were available on a total of 21 906 male subjects free of CVD (see below) at baseline recruitment between January 1999 and 31 December 2004 who were eligible for inclusion in the present study subgroup. There were 3163 cases of hypertensive heart disease (ICD code: 402); ischemic heart diseases (ICD code: 410–414); cardiomyopathy (ICD code: 425); arrhythmia (ICD code: 426–427); congestive heart failure (ICD code: 428); cerebrovascular disease (ICD code: 430–438); coronary artery bypass grafting; percutaneous transluminal angioplasty; diseases of arteries, arterioles, and capillaries (ICD code: 440–448) during follow-up ( $\bar{x} \pm SD$  duration of follow-up:  $2.81 \pm 1.50$  y). The follow-up time for betel chewers ( $n = 3930$ ) and nonchewers ( $n = 17\ 976$ ) were similar at  $2.72 \pm 1.51$  y and  $2.72 \pm 1.52$  y, respectively ( $P = 0.9507$ ).

### Data collection

We used a structured questionnaire to interview subjects who participated in the KCIS program, administered by trained public health nurses or volunteer workers. The questionnaire contained items on 1) lifestyle with details of betel-quin chewing, smoking, alcohol consumption, and physical activity, as well as the associated frequency of consumption and duration of habits; 2) dietary habit on the frequency and amount consumed of meat, vegetables, beans, fish, milk, and coffee; 3) personal and family disease history of diabetes mellitus, hypertension, CVD, and



cerebrovascular disease. Data on dietary habits during the previous 6 mo were also obtained. We displayed the food modes and standard dishes or containers of each food to assist in estimates of portion sizes for food consumed per meal. Frequency of consumption was then categorized into 5 groups: never or seldom, 1–2 times/wk, 3–4 times/wk, 5–6 times/wk, and  $\geq 7$  times/wk. The intake of meat and vegetables was recorded in days per week. The distributions of demographic characteristics, lifestyle factors, dietary factors by current users, ex-users, and nonusers are listed in Table 1.

### Statistical methods

Data were expressed as mean ( $\pm$ SD) for continuous variables and percentage for categorical variables. The comparison of average follow-up time between chewers or nonchewers was made by Student's independent *t* test.

Primary endpoints used in the current study included incident CVD cases and death from CVD. Two survival times were therefore defined; time from entry to the study to death from CVD or to the time to developing overt CVD. Univariate analyses were first performed by using the proportional hazards regression model to estimate the magnitude of the effect of betel-quin chewing on CVD with adjustment for age and education level, which are established factors that affect CVD and betel-quin chewing. The multivariable proportional hazards regression model was further applied to calculating the adjusted hazard ratio (aHR) for betel-quin chewing after adjustment for other significant confounding factors identified in the univariate analyses, including lifestyle factors and family history of diseases related to CVD. *P* values for the independent variables with  $>2$  categories, by likelihood ratio tests, were tested for departure from linearity or quadratic property of trend with the use of analyses of differences in twice log-likelihood between the 2 Cox regression models, one with numerical values for the category of dose-response and one without the variable of interest. *P* values for trends are also reported by comparing the reduced model and the model that included the variables of duration and quantity of betel-quin.

To investigate the dose-response effect of betel-quin chewing on the risk of developing CVD, we classified the rate of use, duration of consumption, and cumulative exposure of betel-quin into 4 groups, by quartiles, among chewers. Adjusting confounders were the same as those used in the multivariable regression model mentioned above.

The proportional hazard assumption for the effect of betel-quin was checked by a calculation of complementary log-log survival function compared with survival time. The statistical significance of whether this assumption was violated was assessed by the incorporation of the interaction term (time  $\times$  betel-quin chewing) in the time-dependent proportional hazards Cox regression model, with adjustment for other confounding factors. All analyses were conducted with the standard statistical software, SAS release 9.1 (SAS Institute Inc, Cary, NC). Two-tailed *P* values of  $< 0.05$  were considered statistically significant.

### RESULTS

The risk of developing CVD increased by 6% for each year of increased age (Table 2). The estimated risks of developing CVD for each of the other relevant risk factors after adjustment for age and educational attainment are also shown in Table 2. After controlling for age and education level, ever chewers had a 23%

increase in the risk of developing CVD than did never chewers. No significant association was found between physical activity, smoking, and alcohol consumption and the occurrence of CVD. Among dietary factors, increased use of milk was negatively associated with CVD risk, but a significant positive association was found for fish intake. Increases in risk were also found for the association between family history of diabetes, hypertension, CVD, and cerebrovascular disease and the risk of CVD in study subjects.

The results of proportional hazards regression model analysis with adjustment for age, education, and all other variables are shown in Table 3. After adjustment for age; education level; occupation; smoking; alcohol consumption; intake of fish, milk, and coffee; physical activity; and family history of diabetes, hypertension, or CVD and cerebrovascular disease, ever chewers still had a significantly increased risk of developing CVD of 24% (95% CI: 11%, 39%). This increased risk was also predicted significantly by age, education, physical activity, milk usage, and family history of hypertension and cerebrovascular disease (Table 3); was increased by fish usage; but was not affected by smoking, alcohol use, or family history of diabetes or CVD (*P* = 0.28, 0.53, 0.42, and 0.26, respectively).

The significant dose-response relations for duration, daily usage rates, and cumulative exposure (years of use  $\times$  daily betel-quin usage rate) to betel-quin chewing with CVD is shown in Figure 1. Positive dose-response relations were found for each of these measures of betel-quin consumption (*P*  $< 0.001$ ), with the use of trend tests, after adjustment for other significant variables. Because the dose-response relation for the duration of betel-quin chewing may look like quadratic function, a quadratic term was included in the model. However, the result was not statistically significant (*P* = 0.19). Another possibility for leading to nonlinear dose-response relation for the duration may be due to sparse cases for the category of duration  $> 19.5$  y.

### DISCUSSION

Detrimental effects of betel-quin chewing have been reported and include significantly increased risks of oral and liver cancers, T2DM, and MetS (1, 5–7), but this is the first prospective study, to the best of our knowledge, to report the linkage between betel-quin chewing and the risk of developing CVD in a large community-population-registry-based study. We found that betel-quin chewing conferred an increase in risk of developing CVD even after taking into account well-recognized risk factors for CVD, including demographics, family history of diabetes, hypertension, lifestyle factors (smoking, alcohol consumption, physical activity), and certain dietary factors. We have also found that this risk was dose dependent in terms of quantity, duration, and cumulative exposure to betel-quin chewing.

Although we cannot rule out the possibility of our findings being confounded by unknown factors not allowed for in the study or by bias because of self-selection for recruitment into the KCIS program, we believe that the deleterious effect of betel-quin chewing on CVD risk may be valid for the following reasons. First, only subjects free of CVD at baseline were included in the study, and dose effects for the increases in CVD risk were found in relation to duration of betel-quin chewing and CVD risk, supporting the suggestion of a causal relation. Second, the finding of a series of dose-response relations for both rate of chewing and cumulative exposure to betel-quin further support the possibility of a



1082  
E

TABLE 1

Demographic characteristics of male subjects in the Keelung Community-based Integrated Screening program according to the habit of betel-quid chewing

	Current users (n = 2100)	Ex-users (n = 1830)	Nonusers (n = 17 976)	P for trend
Age (y)	41.37 ± 10.39 <sup>1</sup>	42.27 ± 10.03	48.77 ± 14.69	—
Follow-up time (y)	2.80 ± 1.54	2.63 ± 1.46	2.72 ± 1.52	
Education				<0.0001
College or above	190 (9.3) <sup>2</sup>	237 (13.3)	5164 (29.6)	
Senior high school	951 (46.5)	851 (47.7)	5388 (30.9)	
Junior high school or below	902 (44.2)	697 (39.0)	6875 (39.5)	
Missing (n)	57	45	549	
Lifestyle factors				
Physical activity				<0.0001
Regular	746 (37.9)	506 (29.3)	3883 (23.3)	
Occasional	1222 (62.1)	1222 (70.7)	12 762 (76.7)	
Missing (n)	132	102	1331	
Occupation				<0.0001
None or retired	643 (30.6)	595 (32.5)	7146 (39.8)	
Manual	651 (31.0)	436 (23.8)	3116 (17.3)	
Teacher, officer holder, military	177 (8.4)	188 (10.3)	2532 (14.1)	
Business, professional	206 (9.8)	199 (10.9)	2112 (11.7)	
Service trade, other	423 (20.1)	412 (22.5)	3070 (17.1)	
Smoking habit				<0.0001
Yes	1932 (92.2)	1734 (94.9)	9360 (52.1)	
No	163 (7.8)	94 (5.1)	8599 (47.9)	
Missing (n)	5	2	17	
Smoking history				<0.0001
Nonsmoker	163 (7.8)	94 (5.1)	8599 (47.9)	
Ex-smoker	134 (6.4)	385 (21.1)	2160 (12.0)	
Current smoker	1798 (85.8)	1349 (73.8)	7200 (40.1)	
Missing (n)	5	2	17	
Alcohol consumption				<0.0001
Yes	1693 (81.6)	1468 (81.1)	7370 (41.3)	
No	383 (18.4)	341 (18.9)	10 492 (58.7)	
Missing (n)	24	21	114	
Alcohol history				<0.0001
Nonuser	383 (18.4)	341 (18.9)	10 492 (58.7)	
Ex-user	127 (6.1)	344 (19.0)	1097 (6.1)	
Current user	1566 (75.4)	1124 (62.1)	6273 (35.1)	
Missing (n)	24	21	114	
Family history among first-degree relatives				
Diabetes				0.0002
Yes	267 (12.7)	252 (13.8)	1938 (10.8)	
No	1833 (87.3)	1578 (86.2)	16 038 (89.2)	
Hypertension				0.1924
Yes	317 (15.1)	292 (16.0)	2600 (14.5)	
No	1783 (84.9)	1538 (84.0)	15 376 (85.5)	
Cerebrovascular disease				0.0071
Yes	108 (5.1)	126 (6.9)	815 (4.5)	
No	1992 (94.9)	1704 (93.1)	17 161 (95.5)	
Cardiovascular disease				0.5510
Yes	92 (4.4)	107 (5.8)	816 (4.5)	
No	2008 (95.6)	1723 (94.2)	17 160 (95.5)	
Dietary factors				
Meat				<0.0001
Never or seldom	432 (20.8)	334 (18.5)	5068 (28.5)	
3-6 times/wk	818 (39.3)	768 (42.6)	6844 (38.4)	
1-2 times/d	585 (28.1)	485 (26.9)	4303 (24.2)	
≥3 times/d	246 (11.8)	216 (12.0)	1590 (8.9)	
Missing (n)	19	27	171	
Vegetables				<0.0001
Never or seldom	78 (3.7)	34 (1.9)	340 (1.9)	
1/2 bowl/d	566 (27.2)	447 (24.7)	3400 (19.0)	
1 bowl/d	551 (26.4)	545 (30.2)	4752 (26.6)	
2 bowls/d	484 (23.2)	453 (25.1)	4837 (27.1)	
≥3 bowls/d	405 (19.4)	328 (18.2)	4522 (25.3)	
Missing (n)	16	23	125	

(Continued)

1/83  
R

TABLE 1 (Continued)

	Current users (n = 2100)	Ex-users (n = 1830)	Nonusers (n = 17 976)	P for trend
Beans				0.0117
Never or seldom	533 (25.7)	382 (21.3)	4786 (26.9)	
1-2 times/wk	111 (5.4)	129 (7.2)	1032 (5.8)	
3-4 times/wk	749 (36.1)	655 (36.5)	6421 (36.1)	
5-6 times/wk	313 (15.1)	307 (17.1)	2363 (13.3)	
≥7 times/wk	366 (17.7)	320 (17.8)	3185 (17.9)	
Missing (n)	28	37	189	
Fish				0.4914
Never or seldom	363 (17.5)	264 (14.7)	3116 (17.5)	
1-2 times/wk	98 (4.7)	128 (7.1)	897 (5.0)	
3-4 times/wk	722 (34.8)	601 (33.4)	5965 (33.6)	
5-6 times/wk	326 (15.7)	303 (16.9)	2455 (13.8)	
≥7 times/wk	565 (27.2)	501 (27.9)	5340 (30.0)	
Missing (n)	26	33	203	
Milk				0.0008
Never or seldom	923 (44.6)	663 (37.0)	6798 (38.3)	
1-2 times/wk	55 (2.7)	76 (4.2)	776 (4.4)	
3-4 times/wk	328 (15.8)	312 (17.4)	3259 (18.4)	
5-6 times/wk	246 (11.9)	259 (14.5)	1957 (11.0)	
≥7 times/wk	519 (25.1)	481 (26.9)	4969 (28.0)	
Missing (n)	29	39	217	
Coffee				0.9774
Never or seldom	772 (47.0)	642 (46.4)	6629 (49.1)	
1-2 times/wk	129 (7.9)	128 (9.2)	907 (6.7)	
3-4 times/wk	217 (13.2)	220 (15.9)	1659 (12.3)	
5-6 times/wk	173 (10.5)	133 (9.6)	1260 (9.3)	
≥7 times/wk	351 (21.4)	262 (18.9)	3058 (22.6)	
Missing (n)	458	445	4463	

<sup>1</sup>  $\bar{x} \pm$  SD (all such values).

<sup>2</sup> n; percentage in parentheses (all such values).

causal link between betel chewing and CVD risk. Third, because these findings were made after controlling for most of the established risk factors associated with CVD risk with multivariable regression analysis, we believe betel-quid chewing is likely to prove to be an independent risk factor for CVD.

The underlying biological mechanisms for the link between betel chewing and CVD may be multiple. Betel-quid components may, by increasing the concentrations of the biochemical variables that are related to MetS, increase inflammatory biomarkers associated with CVD such as MMP9. This postulate is supported by 2 different types of study: first, the significant dose-related association between betel-quid usage and the features of the MetS, as shown in our earlier study on the KCIS cohort (7) and also by the elevated circulating concentrations of inflammatory biomarkers, such as MMP9 and C-reactive protein, reported in betel chewers (13). Increases in CVD risk could also be accounted for by reductions in  $\gamma$ -aminobutyric acid receptor activity because specific arecal alkaloids, such as arecoline, are  $\gamma$ -aminobutyric acid receptor antagonists (15) or by other less well-characterized metabolic effects.

The current results were different from those of the study of Wen et al (18) which reported that betel-quid chewing was not associated with cardiovascular mortality. The evaluated endpoint used for the association in the study of Wen et al (18) was based on mortality from CVD (ICD code: 390-459), whereas ours are evaluated on the basis of incident CVD cases as well as CVD deaths, which may account for the disparity between our positive findings and their nonsignificant results.

Our results show that fish intake is positively associated with an increased incidence of CVD (aHR: 1.03; 95% CI: 1.01, 1.05) (Table 3), which is a discrepancy from the inverse association reported in most cohort studies (19, 20). The probable reason is that the style of fish dishes eaten in the Keelung population usually has a high salt content that may increase the risk of CVD. The second possibility is that study subjects were limited to men because one study reported a significantly reduced risk in cardiac mortality and events only in women and not in men (21).

There were several concerns in the current study. First, it is unsure whether any nonresponse bias exists. Because information on betel quid and other risk factors in association with CVD was not available for nonparticipants, we cannot compare the distributions of these correlates between the 2 groups. However, our prevalence rate of betel-quid chewing (18%) was close to the corresponding figures (19%) reported in a previous nationwide survey (18), making nonresponse bias unlikely. The data used in the current subsidiary analysis about the assessment of our specific hypothesis were derived from a population-registry- and community-based integrated screening program rather than a specific study tailored for examining our hypothesis at the beginning of the screening program. Accordingly, because neither the invited participants nor the principal investigator and the data collector were aware of the hypothesis at baseline, we believe selection into the screening program was not biased for exposure to betel quid or for occurrence of CVD. Indeed, our study is similar in this respect to the Framingham Heart Study that targeted the association between cholesterol and coronary heart



TABLE 2

Adjusted hazard ratios (aHRs) for significant risk factors for cardiovascular disease (CVD) identified with proportional hazards regression models adjusted by age and education level in men (Keelung Community-based Integrated Screening program, 1999-2004)

	CVD (n = 3163)	Total cases (n = 21 906)	aHR	95% CI	P
Age (y) <sup>1</sup>	58.35 ± 13.11 <sup>2</sup>	47.52 ± 14.25	1.06	1.05, 1.06	<0.0001
Follow-up time (y)	1.63 ± 1.26	2.72 ± 1.52			
Education <sup>1</sup>					
College or above	478 (8.5) <sup>1</sup>	5591	1.00		0.0133
Senior high school	673 (9.4)	7190	0.90	0.80, 1.01	0.0841
Junior high school or below	1860 (21.9)	8474	1.04	0.93, 1.16	0.5142
Missing (n)	152	651	N/A		
P for trend					
Betel-quin chewing habit					
Yes	426 (10.8)	3930	1.23	1.11, 1.37	0.0002
No	2737 (15.2)	17 976	1.00		0.0030
Betel-quin chewing history					
Nonchewer	2737 (15.2)	17 976	1.00		0.0001
Ex-chewer	211 (11.5)	1830	1.33	1.15, 1.54	0.0061
Current chewer	215 (10.2)	2100	1.15	0.99, 1.33	0.0035
P for trend					
Lifestyle factors					
Physical activity					
Regular	486 (9.5)	5135	0.96	0.87, 1.05	0.3155
Occasional	2264 (14.9)	15 206	1.00		
Missing (n)	413	1565	N/A		
Occupation					
None or retired	1606 (19.2)	8384	1.00		0.0218
Manual	615 (14.6)	4203	1.15	1.04, 1.27	0.0067
Teacher, officer holder, military	318 (11.0)	2897	1.16	1.02, 1.33	0.0270
Business, professional	313 (12.4)	2517	0.99	0.87, 1.13	0.8778
Service trade, other	311 (8.0)	3905	1.06	0.94, 1.21	0.3474
Smoking habit					
Yes	1879 (14.4)	13 026	1.00	0.93, 1.08	0.9462
No	1282 (14.5)	8856	1.00		
Missing (n)	2	24	N/A		
Smoking history					
Ex-smoker	439 (16.4)	2679	1.06	0.95, 1.18	0.4735
Current smoker	1440 (13.9)	10 347	0.99	0.91, 1.06	
Nonsmoker	1282 (14.5)	8856	1.00		
Missing (n)	2	24	N/A		
P for trend					
Alcohol consumption					
Yes	1486 (14.1)	10 531	1.06	0.99, 1.13	1.0000
No	1667 (14.9)	11 216	1.00		0.1234
Missing (n)	10	159	N/A		
Alcohol history					
Ex-user	262 (16.7)	1568	1.12	0.98, 1.27	0.4287
Current user	1224 (13.7)	8963	1.04	0.97, 1.12	
Nonuser	1667 (14.9)	11 216	1.00		
Missing (n)	10	159	N/A		
P for trend					
Family history among first-degree relatives					
Diabetes					0.8162
Yes	272 (11.1)	2457	1.15	1.01, 1.31	0.0319
No	2891 (14.9)	19 449	1.00		
Hypertension					
Yes	405 (12.6)	3209	1.30	1.17, 1.45	<0.0001
No	2758 (14.8)	18 697	1.00		
Cerebrovascular disease					
Yes	140 (13.3)	1049	1.37	1.15, 1.62	0.0003
No	3023 (14.5)	20 857	1.00		
Cardiovascular disease					
Yes	118 (11.6)	1015	1.22	1.02, 1.47	0.0343
No	3045 (14.6)	20 891	1.00		

(Continued)



1085

TABLE 2 (Continued)

	CVD (n = 3163)	Total cases (n = 21 906)	aHR	95% CI	P
Dietary factors <sup>1</sup>					
Meat			0.98	0.94, 1.01	0.2035
Beans			1.00	0.97, 1.02	0.1736
Vegetables			1.00	0.99, 1.06	0.1642
Fish			1.03	1.01, 1.06	0.0081
Milk			0.98	0.96, 1.00	0.0342
Coffee			0.97	0.95, 1.00	0.0546

<sup>1</sup> Models with adjustment for age and education level by each other.

<sup>2</sup>  $\bar{x} \pm$  SD (all such values).

<sup>3</sup> n; percentage in parentheses (all such values).

<sup>4</sup> Taken as ordinary variables in the regression model. Intake of meat was categorized as "never or seldom," "3-6 times/wk," "1-2 times/d," and "≥3 times/d." Intakes of beans, fish, milk, and coffee were categorized as "never or seldom," "1-2 times/wk," "3-4 times/wk," "5-6 times/wk," and "≥7 times/wk."

disease at the beginning of the study, but then generated a number of publications reporting interests not prespecified. Thus, the present report is considered to be based on a prospective cohort study.

Second, whether the current findings can be generalized to Keelung or to Taiwan as a whole is equivocal. The present study collected data through a community- and population-registry-based integrated screening program in which attendees were invited and sampled through the population registry since 1999.

Because the whole of the eligible population would not be expected to be covered until 2006, the sampling scheme was not like the conventional sampling method for survey or for testing a specific hypothesis. Instead, the residents were sampled and invited area by area according to the organization and feasibility of the screening program. Because our samples were not obtained through probability-based samples such as simple-, cluster-, or stratified-random sampling, the result about the association between betel quid and occurrence of CVD may not be

TABLE 3

Adjusted hazard ratios (aHRs) for significant (independent) risk factors for cardiovascular disease in men identified with the proportional hazards regression model (Keelung Community-based Integrated Screening program, 1999-2004), including all significant risk factors identified<sup>1</sup>

	aHR	95% CI	P
Age (y)	1.06	1.057, 1.064	<0.0001
Education			0.0018
College or above	1.00		
Senior high school	0.83	0.74, 0.93	0.0014
Junior high school or below	0.96	0.86, 1.06	0.3989
P for trend			0.3144
Betel-quid chewing <sup>2</sup>			0.0002
Yes compared with no	1.24	1.11, 1.39	0.0007
Use rate (pieces/d)	1.009	1.004, 1.014	0.0025
Physical activity, regular compared with occasional	0.90	0.83, 0.96	0.1088
Occupation			0.0386
None or retired	1.00		
Manual	1.11	1.01, 1.23	0.2364
Teacher, officer holder, military	1.08	0.95, 1.24	0.3961
Business, professional	0.95	0.83, 1.08	0.5575
Service trade, other	1.04	0.91, 1.18	0.2813
Smoking habit, yes compared with no	0.96	0.89, 1.04	0.5303
Alcohol consumption, yes compared with no	1.02	0.95, 1.11	0.0125
Dietary factors <sup>3</sup>			0.0117
Fish	1.03	1.01, 1.05	0.0125
Milk	0.97	0.95, 0.99	0.0117
Coffee	0.99	0.96, 1.01	0.3059
Family history among first-degree relatives			0.4234
Diabetes mellitus (yes compared with no)	1.06	0.93, 1.20	0.0001
Hypertension (yes compared with no)	1.25	1.12, 1.40	0.0026
Cerebrovascular disease (yes compared with no)	1.30	1.10, 1.55	0.0026
Cardiovascular disease (yes compared with no)	1.12	0.92, 1.35	0.2565

<sup>1</sup> See Table 2.

<sup>2</sup> The effect of betel-quid chewing in this model was expressed in 2 ways with separate models. aHRs for other confounding factors used the model that included betel-quid chewing or not.

<sup>3</sup> Taken as ordinary variables in the regression model. Intakes of fish, milk, and coffee were categorized as "never or seldom," "1-2 times/wk," "3-4 times/wk," "5-6 times/wk," and "≥7 times/wk."



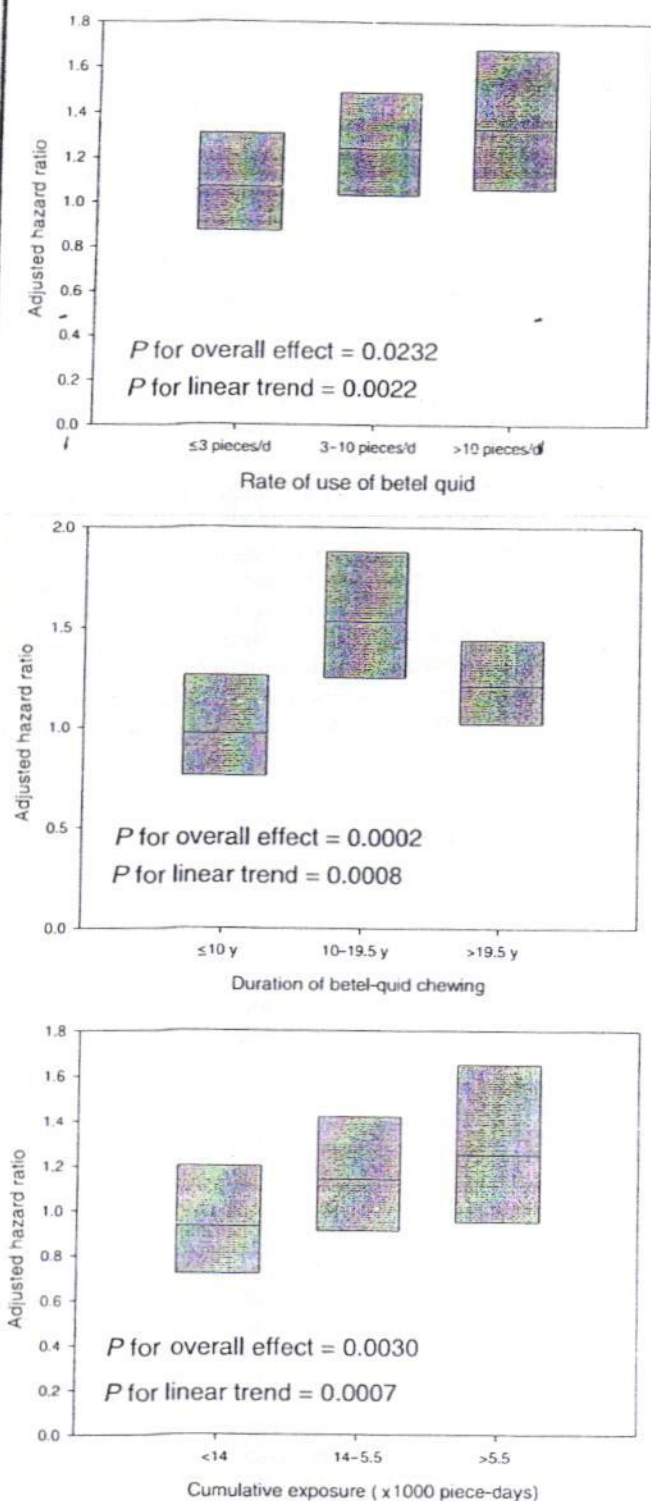

**FIGURE 1.** The dose-response effect of betel-quin chewing on the risk of developing cardiovascular disease in men (Keelung Community-based Integrated Screening program, 1999–2004) by the rate of use, by duration, and by cumulative exposure. The confounders adjusted for in the models included age; education level; physical activity; smoking habit; alcohol consumption; dietary intakes of fish, milk, and coffee; and family history of hypertension, cerebrovascular disease, and cardiovascular disease in first-degree relatives. The horizontal line in the box represents the point estimate of adjusted hazard ratio with lower and upper borders corresponding to the lower and upper boundaries of the 95% CI.

applied to the underlying population in Keelung or Taiwan. However, 3 reasons may still render our result generalizable to other populations in Taiwan. First, our prevalence rate for betel chewing (18%) was close to the corresponding figure (19%) reported in a previous nationwide survey. This enhances the comparability between our study population and the nationwide population in Taiwan. Second, because the attendees, the program director, and the data collector were not aware of this particular test hypothesis, the results on the correlation between betel-quin chewing and occurrence of CVD are likely to be unbiased. Third, because the coverage rate of the study population had reached 30% of men of the underlying population, a large number of study subjects ( $n = 28\,344$ ) may be representative of the underlying population in Keelung city. However, external validity in the current study should be warranted in future study.

The third concern was whether dropouts affected the results of the current study. Because the incident cases were ascertained through the linkage of our cohort with the health insurance claims data, dropouts were only caused by nonclaimed subjects attributed to other causes of deaths, claimed data outside Keelung city, or moving abroad. However, the chance for the latter 2 situations is low (see below). The number of dropouts because of other causes of death was 43 for betel-quin chewers and 352 for nonchewers. We compared the rates of non-CVD death (aHR: 1.28; 95% CI: 0.91, 1.81) and all-cause death (aHR: 1.28; 95% CI: 0.93, 1.77) between the 2 groups, and there was no significance in the differences between the 2 groups in either comparison. Dropouts seem, therefore, unlikely to substantially affect the major results.

Fourth, we used the status of betel-quin chewing at baseline as the measurement of the main interest. It can be argued that the habit of betel-quin chewing could change over time. Such a secular trend has not been measured in the current study. Nonetheless, because the habit of chewing betel quid in terms of daily consumption is unlikely to have a substantial change in Taiwanese men unless a specific intervention program has been introduced for current chewers at enrollment, the lack of such information may not affect the main results.

Finally, the outcome of CVD occurrence is through the linkage of the entire cohort with the health insurance data for costs claimed by local hospitals in Keelung district. Because the KCIS program is an organized screening program conducted by the Keelung City Bureau of Health, all participants with an abnormal finding related to any of the chronic diseases or cancer will be systematically referred to local clinics or local hospitals by public health nurses. The chance that the KCIS participants would seek medical service outside of the Keelung district is low. In addition, 2 external circumstances may also lower this likelihood. The first is that health insurance has imposed copayment on the insured if he or she goes for medical care outside the assigned local medical institution. This financial barrier reduces the possibility of seeking medical care for CVD outside Keelung city. In addition, the entire cohort was also linked with Taiwan National Mortality Registry so as to ensure the ascertainment of deaths from CVD or non-CVD deaths. These circumstances reduce the bias caused by dropouts as mentioned above. Nevertheless, bias caused by loss to follow-up because of participant moving abroad or to other areas in Taiwan cannot be fully ruled out, although the effect may be minor.

In conclusion, we have found, with the use of a prospective community- and population-registry-based cohort study, that

1087  
 R



pede  
 www.ajcn.org  
 3 by g  
 in Jan  
 25, 20

the common habit of chewing betel nut (*Areca catechu*) has independent dose effects to predict increases in the risk of CVD in men. These findings may reflect the significant dose-related increases in MetS previously reported in association with the betel habit or other, as yet unidentified, disorders related to betel chewing.

We thank colleagues in the Bureau of Health in Keelung city for implementing the Keelung Community-based Integrated Screening (KCIS) program and for providing the screening results for participants that formed the basis of the current study.

The author's responsibilities were as follows—AM-FY contributed to data retrieval, data analysis, and writing the draft; L-SC participated in data retrieval, data management, and interpretation of results; Y-HC assisted with data collection and interpretation of results; BJB contributed to the concepts investigated, participated in drafting, interpretation of results, and writing of the manuscript; TH-HC synthesized analyses and led the writing. All authors approved the final version of the text. None of the authors had a personal or financial conflict of interest.

## REFERENCES

- IARC. Betel-quinid and areca-nut chewing and some areca-nut-derived nitrosamines. Monographs on the Evaluation of Carcinogenic Risks to Humans. Vol 85. Lyon, France: IARC, 2004.
- Boucher BJ, Ewen SWB, Stowers JM. Betel nut (*Areca catechu*) consumption and the induction of glucose intolerance in adult CD1 mice and in their F1 and F2 offspring. *Diabetologia* 1994;37:49–55.
- Mannan N, Boucher BJ, Evan SJW. Increased waist size and weight in relation to consumption of *Areca catechu* (betel-nut); a risk factor for increased glycemia in Asians in East London. *Br J Nutr* 2000;83:267–75.
- Benjamin AL. Community screening for diabetes in the National Capital District, Papua New Guinea: is betelnut chewing a risk factor for diabetes? *P N G Med J* 2001;44:101–7.
- Tung TH, Chiu YH, Wu HM, Boucher BJ, Chen THH. A population-based study of the association between *Areca*-nut chewing and type 2 diabetes mellitus in men (KCIS No. 2) *Diabetologia* 2004;47:1776–81.
- Chen THH, Chiu YH, Boucher BJ. Transgenerational effects of betel-quinid chewing on the metabolic syndrome in the Keelung Community-based Integrated Screening Program (KCIS no. 8). *Am J Clin Nutr* 2006;83:688–92.
- Yen AMF, Chiu YH, Chen LS, et al. A population-based study on the association between betel-quinid chewing and the metabolic syndrome in men. *Am J Clin Nutr* 2006;83:1153–60.
- Guh JY, Chuang LY, Chen HC. Betel-quinid use is associated with the risk of the metabolic syndrome in adults. *Am J Clin Nutr* 2006;83:1313–20.
- Expert Panel on Detection, Evaluation, and Treatment of High Blood Cholesterol in Adults. Executive Summary of the Third Report of the National Cholesterol Education Program (NCEP) Expert Panel on Detection, Evaluation, and Treatment of High Blood Cholesterol in Adults (Adult Treatment Panel III). *JAMA* 2001;285:2486–97.
- Lin SK, Chang YJ, Ryu SJ, Chu NS. Cerebral hemodynamic responses to betel chewing: a Doppler study. *Clin Neuropharmacol* 2002;25:244–50.
- Chu NS. Neurological aspects of areca and betel chewing. *Addict Biol* 2002;7:111–4.
- Chu NS. Effects of Betel chewing on the central and autonomic nervous systems. *J Biomed Sci*. 2001;8:229–36.
- Timms PM, Mannan N, Hitman GA, et al. Circulating MMP9, vitamin D and variation in the TIMP-1 response with VDR genotype: mechanisms for inflammatory damage in chronic disorders? *QJM*. 2002;95:787–96.
- Chiang WT, Yang CC, Deng JF, Bullard M. Cardiac arrhythmia and betel nut chewing—is there a causal effect? *Vet Hum Toxicol* 1998;40:287–9.
- Hung DZ, Deng JF. Acute myocardial infarction temporally related to betel nut. *Vet Hum Toxicol* 1998;40:25–8.
- Chen THH, Chiu YC, Luh DL, et al. Taiwan Community-based Integrated Screening Group. Community-based multiple screening model: design, implementation, and analysis of 42,387 participants. *Cancer* 2004;100:1734–43.
- Chiu YH, Chen LS, Chan CC, et al. Health information system for community-based multiple disease screening in Keelung, Taiwan (KCIS No 3). *Int J Med Inform* 2006;75:369–83.
- Wen CP, Tsai SP, Cheng TY, et al. Uncovering the relation between betel-quinid chewing and cigarette smoking in Taiwan. *Tob Control* 2005;14:i16–22.
- Iso H, Kobayashi M, Ishihara J, et al; JPHC Study Group. Intake of fish and n–3 fatty acids and risk of coronary heart disease among Japanese: the Japan Public Health Center-Based (JPHC) Study Cohort I. *Circulation* 2006;113:195–202.
- Wang C, Harris WS, Chung M, et al. n–3 Fatty acids from fish or fish-oil supplements, but not alpha-linolenic acid, benefit cardiovascular disease outcomes in primary- and secondary-prevention studies: a systematic review. *Am J Clin Nutr* 2006;84:5–17.
- Jarvinen R, Knekt P, Rissanen H, Reunanen A. Intake of fish and long-chain n–3 fatty acids and the risk of coronary heart mortality in men and women. *Br J Nutr* 2006;95:824–9.



1688  
6

Hypertens Res. 2008 Mar;31(3):417-23.

### Betel nut chewing is associated with hypertension in Taiwanese type 2 diabetic patients.

Tseng CH.

Department of Internal Medicine, National Taiwan University College of Medicine, and National Taiwan University Hospital, Taipei, Taiwan. ccktsh@ms6.hinet.net

#### Abstract

Betel nut chewing is associated with oral cancers and diabetes. This study investigated whether betel nut chewing could be associated with hypertension in Taiwanese patients with type 2 diabetes mellitus (T2DM). The data of a total of 81,226 (37,226 men and 44,000 women) patients with T2DM obtained from a cross-sectional telephone survey in a national sample of diabetic patients in Taiwan were analyzed. Hypertension was defined by a positive history or reported systolic blood pressure  $\geq 140$  mmHg and/or diastolic blood pressure  $\geq 90$  mmHg. Analyses were performed in separate sexes with consideration paid to the potential confounding effects of age, diabetic duration, body mass index and smoking. The prevalences of betel nut chewing in men and women were 20.4% and 1.1%, respectively. Betel nut chewing was more common in the younger age groups of the male sex. The multivariate-adjusted odds ratios for hypertension in chewers vs. non-chewers were 1.067 (1.007-1.131) and 1.897 (1.534-2.346) for men and women, respectively. In multiple linear regression, although no adjustment was made for the use of antihypertensive agents, betel nut chewing was significantly associated with blood pressure, with regression coefficients of  $0.958 \pm 0.163$  (SEM) for systolic and  $0.441 \pm 0.108$  for diastolic blood pressure in men; and the respective values for women were  $1.805 \pm 0.618$  and  $1.198 \pm 0.393$ . In conclusion, betel nut chewing was significantly associated with hypertension in Taiwanese patients with T2DM and the association was stronger in women.

1089  
8

## Research Article

# Betel Nut Chewing and Subclinical Ischemic Heart Disease in Diabetic Patients

Chin-Hsiao Tseng<sup>1,2</sup>

<sup>1</sup> Department of Internal Medicine, National Taiwan University College of Medicine, Taipei 10051, Taiwan

<sup>2</sup> Division of Endocrinology and Metabolism, Department of Internal Medicine, National Taiwan University Hospital, No. 7 Chung-Shan South Road, Taipei 10002, Taiwan

Correspondence should be addressed to Chin-Hsiao Tseng, ccktsh@ms6.hinet.net

Received 17 August 2010; Accepted 3 October 2010

Academic Editor: Undurti N. Das

Copyright © 2011 Chin-Hsiao Tseng. This is an open access article distributed under the Creative Commons Attribution License, which permits unrestricted use, distribution, and reproduction in any medium, provided the original work is properly cited.

**Background.** This study investigated the association between betel nut chewing and subclinical ischemic heart disease (IHD) in Taiwanese type 2 diabetic patients. **Methods.** A total of 394 male patients aging  $\geq 45$  years and without previous heart disease were studied. Among them 349 had no habit of chewing betel nut and 45 possessed the habit for  $\geq 5$  years. Subclinical IHD was diagnosed by a Minnesota-coded resting electrocardiogram and was present in 71 cases. Statistical analyses were performed considering confounding effects of age, diabetic duration, smoking, body mass index, blood pressure, dyslipidemia, and metabolic control status. **Results.** Betel nut chewers were younger and had higher prevalence of smoking (86.7% versus 60.5%), higher body mass index, poorer glycemic control, and higher prevalence of subclinical IHD (28.9% versus 16.6%). Patients with subclinical IHD were older and had higher prevalence of betel nut chewing (18.0% versus 9.9%). The multivariate-adjusted odds ratio for subclinical IHD for chewers versus nonchewers was 4.640 (1.958–10.999). The adjusted odds ratios in younger or older patients divided by the median age of 63 years were similar: 4.724 (1.346–16.581) and 4.666 (1.278–17.028), respectively. **Conclusions.** Betel nut chewing is significantly associated with increased risk of subclinical IHD.

## 1. Introduction

Areca nut is the seed of the palm tree *Areca catechu*, which is the fourth most commonly used psychoactive substance, after caffeine, nicotine, and alcohol [1]. Because areca nut is always consumed with the leaf of *Piper betle*, chewing of areca nut has always been referred to as "betel nut chewing" in the English literature [2]. There is an estimated 600 million people chewing betel nut worldwide [3]. It is a common habit and is a means of social interaction in Asia, particularly the South Pacific islands, Southeast Asia, Papua New Guinea, Bangladesh, Pakistan, and India [1–4]. Chewing of betel nut was forbidden in Taiwan during the Japanese reign more than 60 years ago [4]. But this habit has become popular in Taiwan during the past two to three decades, and it has been estimated that about 2.4 millions, or 11.4%, of the total population are chewing betel nut [5]. The chewing population in Taiwan keeps on increasing, especially in the male sex of the younger generation [6, 7]. In Taiwan, unripe

areca nut is commonly chewed with a mixture of lime and the leaf or flower of the *Piper betle*, but without tobacco [4].

Betel nut chewing has been linked to a variety of health problems including oral lesions of leukoplakia, submucosal fibrosis, squamous cell carcinoma and periodontal disease [8, 9], albuminuria in diabetic patients [10], disruption of gastric mucosal barriers [11], aggravation of asthma [12], induction of extrapyramidal syndrome [13], milk-alkali syndrome (in a case report) [14], induction of uterine cervical dysplasia [15], cancers of the esophagus [16] and liver [17], and low birth weight of babies born to mothers chewing betel nut [18]. In more recent population-based studies in Taiwan, betel nut chewing is also associated with a higher risk of type 2 diabetes mellitus (T2DM) [19], hypertension [20], and total and cerebrovascular deaths [21].

Studies on the cardiovascular effects of betel nut chewing are rare. Hemodynamic changes have been observed during betel nut chewing [7]. However, whether the prolonged chewing of betel nut could exert an effect on the heart

has not been previously studied. Therefore, the purpose of this study was to evaluate whether betel nut chewing could be associated with the prevalence of subclinical IHD in a subgroup of patients with T2DM recruited as a long-term follow-up cohort in Taiwan.

## 2. Methods

**2.1. Study Subjects.** The study was approved by an ethics committee of the Department of Health, Taiwan, and the subjects voluntarily participated in the study. More than 96% of the population of Taiwan is covered by a compulsory National Health Insurance program. A total of 256,036 patients using this health insurance program were assembled from 1995 to 1998 [22–24]. Baseline data was collected by questionnaires on the onset symptoms and confirmation of diabetic diagnosis from 93,484 patients of the original cohort [22–24]. At random, 4,164 patients were selected from the main cluster of 93,484 patients and invited to participate in a health examination. A total of 1,441 patients participated in the health examination from March 1998 to September 2002. After excluding 21 patients with type 1 diabetes mellitus (T1DM), there were a total of 1420 patients diagnosed as T2DM. The patients with T2DM did not show a history of diabetic ketoacidosis at the onset of diabetes and were being treated with either oral antidiabetic drugs or insulin at the time of recruitment. For those under insulin treatment, none received such treatment within one year of diagnosis of diabetes mellitus.

Patients with T1DM were excluded because of the small number of cases who might also have different pathogenesis of IHD. Women with T2DM were further excluded because the habit of betel nut chewing is very uncommon in women in Taiwan [6, 7, 25]. Taking into account the possible requirement of prolonged chewing for the manifestations of clinical outcomes, this study recruited only adult male patients aging  $\geq 45$  years, and chewers must be current chewers and have retained the habit for  $\geq 5$  years at the time of recruitment. Patients with a clinical history of heart disease including angina pectoris, myocardial infarction, congestive heart failure or under treatment for such were also excluded because of the impossibility to clarify the correctness of temporality between cause and effects and because of the potential confounding effect caused by treatments. As a result, a total of 394 men with T2DM were included in this study. They were divided into two groups: one with no habit of chewing betel nut and the other should have persistently chewed betel nut for more than 5 years at the time of recruitment.

**2.2. Diagnosis of Subclinical Ischemic Heart Disease.** Resting electrocardiogram was performed in each subject, and the Minnesota codes were used to code the electrocardiograms. The coder was blind to the history or the biochemical data of the subjects. Subclinical IHD was defined by Minnesota codes of coronary probable (1.1, 1.2, 7.1) and coronary possible (1.3, 4.1–4.3, 5.1–5.3) [26].

**2.3. Measurements of Blood Biochemistry and Other Covariates.** Blood samples were collected in the early morning after

fasting for at least 12 hours. Fasting plasma glucose (FPG), serum total cholesterol (TC), and triglyceride (TG) were measured by an automatic biochemistry analyzer (Cobas Mira S, Roche Diagnostica, Basel, Switzerland) with reagents obtained from Randox Laboratories Ltd. (Antrim, UK) [27].

The patients' age, duration of diabetes, body mass index (BMI), smoking status, and systolic (SBP) and diastolic blood pressure (DBP) were recorded or measured. Duration of diabetes was defined as the time period in years between the time being recruited into the study and the time diabetes was diagnosed. Blood pressure was measured on the right arm after 20 minutes rest in a sitting position with a mercury sphygmomanometer by the auscultatory method. Body height (in centimeters) was measured by having the subjects stand with their heels, buttocks, and heads against a wall. A flat object was placed on top of the subjects' head, and their height was marked on a tape measure affixed to the wall. Body weight was measured in kilograms with a standard portable scale. Body height and body weight were measured with the patient wearing light clothes and without socks and shoes. BMI was calculated as body weight in kilograms divided by the square of the body height in meters. Hypertension was defined by a positive history with the use of antihypertensive agents or by SBP  $\geq 140$  mmHg and/or DBP  $\geq 90$  mmHg. Dyslipidemia was diagnosed by the use of lipid-lowering agents and/or a TC level  $\geq 200$  mg/dL and/or TG  $\geq 150$  mg/dL.

**2.4. Statistical Analyses.** Data were expressed as mean (SD) or percentage. A  $P < .05$  was considered statistically significant, while  $.05 < P < .1$  was borderline significant. Age was divided into two groups by the median and the prevalences of subclinical IHD between chewers and nonchewers were compared by Chi-square test in the respective age groups. The baseline characteristics between chewers and nonchewers and between patients with subclinical IHD and those without subclinical IHD were compared by Student's *t*-test for continuous variables and by Chi-square test for categorical variables. Logistic regression models estimating the odds ratios for subclinical IHD were created for all patients and for patients in the respective two age groups divided by the median of age. These regression models were generated in the following 3 ways: (1) unadjusted; (2) adjusted for variables found to be different between chewers and non-chewers, or between patients with and without subclinical IHD with  $P$  values  $< .1$ ; (3) adjusted for all potential covariates (i.e., age, diabetic duration, body mass index, smoking, hypertension, dyslipidemia, FPG, SBP, DBP, TC, and TG).

## 3. Results

Figure 1 shows the prevalences of subclinical IHD in chewers and non-chewers in the respective age groups divided by the median of 63 years old. The prevalences of subclinical IHD differed significantly between chewers and non-chewers in either the younger or the older age groups ( $P < .05$ ).

1091  
✓

TABLE 1: Comparisons between patients chewing and not chewing betel nut and having and not having subclinical ischemic heart disease (IHD).

	Betel nut chewing		Subclinical IHD	
	No	Yes	No	Yes
<i>n</i>	349	45	323	71
Age, years	63.9 (9.3)	56.3 (8.6)**	62.0 (9.4)	67.6 (9.1)**
Diabetic duration, years	10.4 (7.6)	10.3 (8.8)	10.4 (7.6)	10.7 (8.5)
Body mass index, kg/m <sup>2</sup>	24.5 (3.0)	25.9 (3.7)**	24.6 (3.2)	24.8 (2.9)
Smoking, %	60.5	86.7**	63.2	64.8
Fasting plasma glucose, mg/dL	159.4 (57.3)	178.6 (74.8)*	162.2 (56.5)	159.1 (72.9)
Hypertension, %	52.4	60.0	52.3	57.8
Systolic blood pressure, mmHg	132.8 (15.8)	131.9 (15.1)†	132.1 (15.4)	135.2 (17.5)
Diastolic blood pressure, mmHg	83.2 (8.8)	84.8 (7.0)	83.4 (8.4)	83.1 (9.6)
Dyslipidemia, %	56.0	68.9	56.5	62.0
Total cholesterol, mg/dL	199.8 (45.9)	196.9 (38.2)	199.1 (45.1)	201.3 (44.9)
Triglyceride, mg/dL	168.7 (193.3)	180.0 (83.1)	168.9 (196.2)	174.9 (114.6)
Ischemic heart disease, %	16.6	28.9*	—	—
Betel nut chewing, %	—	—	9.9	18.0*

\*  $P < .05$ ; \*\*  $P < .01$ .FIGURE 1: Prevalence of subclinical ischemic heart disease (IHD) between betel nut chewers (shaded column) and non-chewers (black column) by median of age ( $P < .05$  for each subgroup of age).

Table 1 compares the baseline characteristics between chewers and nonchewers and between patients with and without subclinical IHD. Chewers were significantly younger in age, more prevalent in smoking and subclinical IHD, and had higher BMI and poorer glycemic control. Patients with subclinical IHD were significantly older and more prevalent in betel nut chewing.

Table 2 shows the odds ratios for subclinical IHD. Chewers consistently showed a significantly higher risk of subclinical IHD in either the older or the younger age group in all of the models.

#### 4. Discussion

The findings of this study clearly demonstrated a higher risk of subclinical IHD in T2DM patients without a previous history of heart disease (Tables 1 and 2; Figure 1). This association was independent of traditional risk factors, and could be demonstrated in either the younger or the older

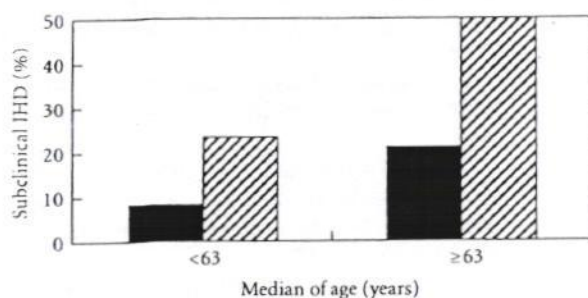
patients (Figure 1; Table 2). To the best of our knowledge, this was the first study demonstrating a link between betel nut chewing and subclinical IHD. The association was consistent, and the magnitude of the odds ratios was large.

Although the real pathogenetic mechanism(s) remains unknown, some of the biological effects associated with the ingredients of areca nut or the compounds formed during chewing might explain some of the possibilities. The common preparations of the betel nut quid in Taiwan consist of three major components: the nut of *Areca catechu*, quicklime, and the leaf or the flower of *Piper betle* [4]. Areca nut contains arecoline which has a cholinergic action at the muscarinic and nicotinic receptors [28]. This cholinergic action on the central nervous system could possibly produce the cortical arousal and alertness which is always claimed as one of the merits experienced by the betel nut chewers. On the other hand, arecoline might stimulate the hypothalamic-pituitary-adrenal axis through a centrally mediated corticotrophin-releasing hormone-dependent mechanism in rats [29]. In the presence of lime, arecoline is hydrolyzed to arecaidine, which lacks the parasympathomimetic effects of arecoline [4] and exerts sympathetic effect by inhibition of  $\gamma$ -aminobutyric acid (GABA) uptake [30]. However, a later study suggested that arecaidine may not cross the blood-brain barrier and the central effects may involve transmitters other than GABA [31]. The aromatic substances (e.g., eugenol, isoeugenol, and hydroxychavicol) in the flower or leaf of *Piper betle* can stimulate the release of catecholamines from chromaffin cells *in vitro* [32], and circulating norepinephrine and epinephrine levels are elevated following betel nut chewing [33]. However, these sympathomimetic effects of arecoline might be mediated by central cholinergic mechanisms [34]. Therefore, both areca nut and *Piper betle* flower may exert sympathomimetic effects. Whether these sympathomimetic effects may be responsible for the subclinical IHD observed in the present study awaits further investigations. Reactive

1092  
E

TABLE 2: Odds ratios for subclinical ischemic heart disease comparing chewers versus nonchewers of betel nut.

	Odds ratio (95% confidence interval)		
	<63 years old	≥63 years old	All ages
Unadjusted	2.982 (1.087–8.182)*	3.267 (1.004–10.629)*	2.038 (1.008–4.118)*
Adjusted for age, BMI, smoking, and FPG	4.153 (1.280–13.471)*	4.183 (1.170–14.955)*	4.269 (1.837–9.920)**
Adjusted for all covariates (age, diabetic duration, BMI, smoking, hypertension, dyslipidemia, FPG, SBP, DBP, TC, and TG)	4.724 (1.346–16.581)*	4.666 (1.278–17.028)*	4.640 (1.958–10.999)**

\*  $P < .05$ ; \*\*  $P < .01$ .

oxygen species and *N*-nitroso compounds can also be formed in the oral cavity during chewing of betel nut [35, 36]. *In vitro* studies also demonstrated that betel nut components increased the release of inflammatory mediators such as prostanoids, interleukin-6, and tumor necrosis factor- $\alpha$  [37, 38]. The production of these chemical agents has always been regarded as the mediators of carcinogenicity and diabetogenicity associated with betel nut chewing. Whether they can also be responsible for a hemodynamic or structural change in the coronary vascular system leading to subclinical IHD is an issue worthy of further investigation.

Some limitations deserve mentioning. This study was conducted in the diabetic patients, and it is not known whether similar effects can be extended to the general population without diabetes. Future studies should be aimed at a dose-response relationship and taking the duration of betel nut chewing into consideration. Longitudinal prospective studies are required to clarify the cause/effect relationship between betel nut chewing and subclinical IHD.

In conclusions, betel nut chewing in Taiwanese patients with T2DM is associated with subclinical IHD. While the chewing of betel nut is decreasing in some countries like Thailand [39], the prevalence keeps on increasing in Taiwan, especially in the younger generation. It is urgent for policy makers to implement programs of health education to the younger generation to curb the increasing prevalence of betel nut chewing and its associated health problems.

### Acknowledgments

The author thanks the following institutes in Taiwan for their continuous support on the epidemiologic studies of diabetes and arsenic-related health hazards: the New Century Health Care Promotion Foundation; the National Genotyping Center of National Research Program for Genomic Medicine, National Science Council; the Department of Health (DOH89-TD-1035; DOH97-TD-D-113-97009); the National Taiwan University Hospital Yun-Lin Branch (NTUHYL96.G001); the National Science Council (NSC-86-2314-B-002-326, NSC-87-2314-B-002-245, NSC88-2621-B-002-030, NSC89-2320-B002-125, NSC-90-2320-B-002-197, NSC-92-2320-B-002-156, NSC-93-2320-B-002-071,

NSC-94-2314-B-002-142, NSC-95-2314-B-002-311, and NSC-96-2314-B-002-061-MY2).

### References

- [1] P. C. Gupta and C. S. Ray, "Epidemiology of betel quid usage," *Annals of the Academy of Medicine Singapore*, vol. 33, no. 4, 2004.
- [2] P. C. Gupta and S. Warnakulasuriya, "Global epidemiology of areca nut usage," *Addiction Biology*, vol. 7, no. 1, pp. 77–83, 2002.
- [3] B. S. Nelson and B. Heischouer, "Betel nut: a common drug used by naturalized citizens from India, Far East Asia, and the South Pacific Islands," *Annals of Emergency Medicine*, vol. 34, no. 2, pp. 238–243, 1999.
- [4] N.-S. Chu, "Effects of Betel chewing on the central and autonomic nervous systems," *Journal of Biomedical Science*, vol. 8, no. 3, pp. 229–236, 2001.
- [5] A. Huang, "Betel nuts, better not," *Free China Review*, vol. 47, pp. 18–27, 1997.
- [6] M.-S. Yang, I.-H. Su, J.-K. Wen, and Y.-C. Ko, "Prevalence and related risk factors of betel quid chewing by adolescent students in southern Taiwan," *Journal of Oral Pathology and Medicine*, vol. 25, no. 2, pp. 69–71, 1996.
- [7] S.-K. Lin, Y.-J. Chang, S.-J. Ryu, and N.-S. Chu, "Cerebral hemodynamic responses to betel chewing: a doppler study," *Clinical Neuropharmacology*, vol. 25, no. 5, pp. 244–250, 2002.
- [8] C. R. Trivedy, G. Craig, and S. Warnakulasuriya, "The oral health consequences of chewing areca nut," *Addiction Biology*, vol. 7, no. 1, pp. 115–125, 2002.
- [9] F. S. Mehta, M. K. Sanjana, and M. A. Baretto, "Relation of betel leaf chewing to periodontal disease," *The Journal of the American Dental Association*, vol. 50, pp. 531–536, 1955.
- [10] C.-H. Tseng, "Betel nut chewing is independently associated with urinary albumin excretion rate in type 2 diabetic patients," *Diabetes Care*, vol. 29, no. 2, pp. 462–463, 2006.
- [11] C.-R. Hung and J.-T. Cheng, "Betel quid chewing damaged gastric mucosa: protective effects of cimetidine and sodium bicarbonate," *Chinese Journal of Physiology*, vol. 37, no. 4, pp. 213–218, 1994.
- [12] R. F. H. Taylor, N. Al-Jarad, L. M. E. John, D. M. Conroy, and N. C. Barnes, "Betel-nut chewing and asthma," *The Lancet*, vol. 339, no. 8802, pp. 1134–1136, 1992.

- [13] M. Deahl, "Betel nut-induced extrapyramidal syndrome: an unusual drug interaction," *Movement Disorders*, vol. 4, no. 4, pp. 330–333, 1989.
- [14] S.-H. Lin, Y.-F. Lin, S. Cheema-Dhadli, M. R. Davids, and M. L. Halperin, "Hypercalcaemia and metabolic alkalosis with betel nut chewing: emphasis on its integrative pathophysiology," *Nephrology Dialysis Transplantation*, vol. 17, no. 5, pp. 708–714, 2002.
- [15] R. N. Chakrabarti, K. Dutta, K. Ghosh, and S. Sikdar, "Uterine cervical dysplasia with reference to the betel quid chewing habit," *European Journal of Gynaecological Oncology*, vol. 11, no. 1, pp. 57–59, 1990.
- [16] M.-T. Wu, D.-C. Wu, H.-K. Hsu, E.-L. Kao, and J.-M. Lee, "Relationship between site of oesophageal cancer and areca chewing and smoking in Taiwan," *British Journal of Cancer*, vol. 89, no. 7, pp. 1202–1204, 2003.
- [17] C.-A. Sun, D.-M. Wu, C.-C. Lin et al., "Incidence and cofactors of hepatitis C virus-related hepatocellular carcinoma: a prospective study of 12,008 men in Taiwan," *American Journal of Epidemiology*, vol. 157, no. 8, pp. 674–682, 2003.
- [18] C. de Costa and A. R. Griew, "Effects of betel chewing on pregnancy outcome," *Australian and New Zealand Journal of Obstetrics and Gynaecology*, vol. 22, no. 1, pp. 22–24, 1982.
- [19] C.-H. Tseng, "Betel nut chewing and incidence of newly diagnosed type 2 diabetes mellitus in Taiwan," *BMC Research Notes*, vol. 3, article 228, 2010.
- [20] C.-H. Tseng, "Betel nut chewing is associated with hypertension in Taiwanese type 2 diabetic patients," *Hypertension Research*, vol. 31, no. 3, pp. 417–423, 2008.
- [21] T.-Y. Lan, W.-C. Chang, Y.-J. Tsai, Y.-L. Chuang, H.-S. Lin, and T.-Y. Tai, "Areca nut chewing and mortality in an elderly cohort study," *American Journal of Epidemiology*, vol. 165, no. 6, pp. 677–683, 2007.
- [22] C.-H. Tseng, C.-P. Tseng, C.-K. Chong et al., "Increasing incidence of diagnosed type 2 diabetes in Taiwan: analysis of data from a national cohort," *Diabetologia*, vol. 49, no. 8, pp. 1755–1760, 2006.
- [23] C.-H. Tseng, C.-K. Chong, and T.-Y. Tai, "Secular trend for mortality from breast cancer and the association between diabetes and breast cancer in Taiwan between 1995 and 2006," *Diabetologia*, vol. 52, no. 2, pp. 240–246, 2009.
- [24] C.-H. Tseng, C.-K. Chong, C.-P. Tseng, and T.-T. Chan, "Age-related risk of mortality from bladder cancer in diabetic patients: a 12-year follow-up of a national cohort in Taiwan," *Annals of Medicine*, vol. 41, no. 5, pp. 371–379, 2009.
- [25] C.-H. Tseng, C.-K. Chong, T.-T. Chan et al., "Optimal anthropometric factor cutoffs for hyperglycemia, hypertension and dyslipidemia for the Taiwanese population," *Atherosclerosis*, vol. 210, no. 2, pp. 585–589, 2010.
- [26] C.-H. Tseng, "Waist-to-height ratio and coronary artery disease in Taiwanese type 2 diabetic patients," *Obesity*, vol. 16, no. 12, pp. 2754–2759, 2008.
- [27] C.-H. Tseng, C.-P. Tseng, and C.-K. Chong, "Joint effects of hypertension, smoking, dyslipidemia and obesity and angiotensin-converting enzyme DD genotype on albuminuria in Taiwanese patients with type 2 diabetes mellitus," *Clinical Biochemistry*, vol. 43, no. 7-8, pp. 629–634, 2010.
- [28] O. Nieschulz, "Pharmacology of the active substances in betel. 3. Experiments with arecaidine," *Arzneimittel-Forschung*, vol. 20, no. 2, pp. 218–229, 1970 (German).
- [29] A. E. Calogero, T. C. Kamilaris, M. T. Gomez et al., "The muscarinic cholinergic agonist arecoline stimulates the rat hypothalamic-pituitary-adrenal axis through a centrally-mediated corticotropin-releasing hormone-dependent mechanism," *Endocrinology*, vol. 125, no. 5, pp. 2445–2453, 1989.
- [30] G. A. R. Johnston, P. Krosggaard-Larsen, and A. Stephanson, "Betel nut constituents as inhibitors of  $\gamma$  aminobutyric acid uptake," *Nature*, vol. 258, no. 5536, pp. 627–628, 1975.
- [31] D. Lodge, G. A. R. Johnston, D. R. Curtis, and S. J. Brand, "Effects of the Areca nut constituents arecaidine and guvacine on the action of GABA in the cat central nervous system," *Brain Research*, vol. 136, no. 3, pp. 513–522, 1977.
- [32] C. K. Wang and L. S. Hwang, "Effect of betel quid on catecholamine secretion from adrenal chromaffin cells," *Proceedings of the National Science Council, Republic of China. Part B*, vol. 21, no. 4, pp. 129–136, 1997.
- [33] N.-S. Chu, "Sympathetic response to betel chewing," *Journal of Psychoactive Drugs*, vol. 27, no. 2, pp. 183–186, 1995.
- [34] J. I. Nurnberger Jr., D. C. Jimerson, and S. Simmons-Alling, "Behavioral, physiological, and neuroendocrine responses to arecoline in normal twins and 'Well State' bipolar patients," *Psychiatry Research*, vol. 9, no. 3, pp. 191–200, 1983.
- [35] U. Nair, H. Bartsch, and J. Nair, "Alert for an epidemic of oral cancer due to use of the betel quid substitutes gutkha and pan masala: a review of agents and causative mechanisms," *Mutagenesis*, vol. 19, no. 4, pp. 251–262, 2004.
- [36] B. J. Boucher and N. Mannan, "Metabolic effects of the consumption of Areca catechu," *Addiction Biology*, vol. 7, no. 1, pp. 103–110, 2002.
- [37] J.-P. Peng, C.-Y. Su, H.-C. Chang, C.-Y. Chai, and W.-C. Hung, "Overexpression of cyclo-oxygenase 2 in squamous cell carcinoma of the hypopharynx," *Human Pathology*, vol. 33, no. 1, pp. 100–104, 2002.
- [38] J.-H. Jeng, Y.-J. Wang, B.-L. Chiang et al., "Roles of keratinocyte inflammation in oral cancer: regulating the prostaglandin E2, interleukin-6 and TNF- $\alpha$  production of oral epithelial cells by areca nut extract and arecoline," *Carcinogenesis*, vol. 24, no. 8, pp. 1301–1315, 2003.
- [39] P. A. Reichart, "Oral cancer and precancer related to betel and miang chewing in Thailand: a review," *Journal of Oral Pathology and Medicine*, vol. 24, no. 6, pp. 241–243, 1995.

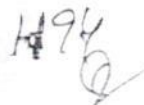
H94  

ARECA NUT SYMPOSIUM

Neurological aspects of areca and betel chewing

NAI-SHIN CHU

Department of Neurology, Chang Gung University College of Medicine, Taipei, Taiwan

Abstract

Betel quid chewing has been claimed to produce a sense of well-being, euphoria, warm sensation of the body, sweating, salivation, palpitation, heightened alertness and increased capacity to work. These effects suggest that betel quid chewing affects predominantly the central and autonomic nervous systems. Several studies have been conducted to elucidate the central and autonomic effects of betel quid chewing. The results are: (1) betel quid chewing increased the heart rate with onset within 2 minutes, maximal effect within 4-6 minutes and an average duration of 16.8 minutes. The cardio-acceleratory response was more prominent for fresh and occasional chewers than for habitual chewers; (2) betel quid chewing increased the skin temperature with onset and duration similar to a cardio-acceleratory response. The hyperthermic effect was abolished by atropine and partly inhibited by propranolol. (3) Betel quid chewing had no effect on simple reaction time but shortened the choice reaction time. (4) Betel quid chewing produced widespread cortical desynchronization of EEG. (5) Chewing of one or two betel quids attenuated the sympathetic skin response while continued consumption of more than two betel quids affected the RR interval variation. (6) Plasma concentrations of noradrenaline and adrenaline were elevated during betel quid chewing. These studies have confirmed several effects claimed by betel quid users. The effects of betel quid chewing appeared to be habit-related and dose-dependent. Although arecoline has been thought to be responsible for several effects of betel quid chewing, the present data suggest a role also played by sympathetic activation.

Introduction

The use of betel nut masticatory has been widespread in Southeast Asia and the South Pacific islands, and highly valued for its psychoactive properties in reducing tension, producing euphoria or a sense of well-being, increasing the capacity to work and providing the means of social interactions and rituals.<sup>1,2</sup>

The claimed effects of betel quid chewing are euphoria, a sense of well-being, palpitation, salivation, diaphoresis, heightened alertness, warm sensation of the body, combat against

hunger and increased stamina.<sup>1-3</sup> Arecoline, the major alkaloid of the areca nut, has been thought to be responsible for several of the claimed effects.<sup>4-6</sup> Arecoline is one of the naturally occurring alkaloids, with parasympathomimetic properties acting on both muscarinic and nicotinic receptors.<sup>5,6</sup> Arecoline induces an arousal response in animals and a cardio-acceleratory response in humans.<sup>7-11</sup> However, there are other alkaloids in areca nut, i.e. arecaidine and guvacine, which are GABA uptake inhibitors.<sup>12,13</sup> Phenolic compounds in the piper betle flower or

Correspondence to: Nai-Shin Chu MD, Department of Neurology, Chang Gung Memorial Hospital, 199 Tung-Hwa N Road, Taipei, Taiwan. Tel: 886 3 3281200, ext. 8417; fax: 86 3 3287226; e-mail: chu060@adm.cgmh.com.tw

1095  
8

leaf are stimulators to release catecholamines from chromaffin cells *in vitro*.<sup>14</sup>

Despite some regional variations, betel quid preparations consist of the nut of the palm tree *Areca catechu*, quicklime and some type of psychoactive leaf of the plants.<sup>1-3</sup> Undoubtedly, chewing of betel quid causes different reactions and interactions before those active compounds are absorbed into the circulation.<sup>15</sup> Arecoline in the presence of lime is converted into arecaine, which lacks typical parasympathetic properties, and the amount of arecoline entering the circulation may not be sufficient to exert cholinergic and other actions. Therefore, interpretation of experimental data are difficult unless these data are obtained from humans and active compounds in the blood or the brain are determined. Despite the antiquity and popularity of betel chewing, its claimed effects have not been investigated systematically in humans. This paper will address the psychoneurological aspects of betel quid chewing from our human studies, and hopefully warrants further research.

#### Neurological aspects of betel chewing

The following studies were carried in normal healthy subjects. The betel quid used was the most popular one in Taiwan, which consists of fresh nut of *A. catechu* (areca nut), piper betle flower and slacked lime paste, which contains a Chinese herb (*Acacia catechu*) to promote the flavour. Controls were usually those who chewed areca nut only and those who chewed fruit-flavoured chewing gum. Study subjects were habitual users, but in some studies might include fresh chewers and occasional chewers.

#### Cardiovascular response

All three groups of habitual, occasional and fresh chewers showed an increase in heart rate following betel quid chewing.<sup>16</sup> The onset was within 2 minutes after chewing, peak effect was reached within 4-6 minutes and the effect lasted for an average of 16.8 minutes. The mean increase in heart rate was 13.3 beats/min for habitual users, 16.2 beats/min for occasional users, and 17.0 beats/min for fresh users, suggesting tolerance or habituation for chronic users. On the other hand, blood pressure was significantly elevated only for the fresh chewers.

#### Heightened alertness

To investigate the claims that betel quid chewing increases alertness and improves motor responses, simple and choice reaction times (SRT and CRT) were studied in habitual users.<sup>17</sup> Control consisted of chewing gum and practice groups. In the SRT task, reaction times were not different among the three groups. In the CRT task, the betel quid and chewing gum groups showed a significant shortening of reaction time, but the betel quid group had a higher degree of statistical significance ( $p < 0.0001$  vs  $p = 0.0379$ ). The data suggest that shortening of CRT from betel quid chewing is probably due partly to chewing itself and partly to a cholinergic arousal mechanism.

EEG activity of 52 betel quid users was studied by spectral analysis and topographic mapping before and during betel quid chewing.<sup>18</sup> Betel quid chewing increased both alpha and beta activities but decreased theta activity. These effects were most prominent for beta rhythms. Topographic mapping revealed that altered rhythms were restricted to the occipital areas for alpha and widespread for both beta and theta. The data suggest that betel quid chewing causes EEG changes associated with a state of arousal and, to a lesser degree, a state of relaxation.

#### Body temperature effect

Because betel quid chewing produces sweating, facial flush and a warm sensation of the body, skin temperature was recorded before and during betel quid chewing in habitual chewers.<sup>19</sup> Betel quid chewing caused an increase in skin temperature from 0.5 to 2.0°C, and this hyperthermic response was abolished by atropine and partially inhibited by propranolol. The data suggest that both parasympathetic and sympathetic mechanisms are involved in the skin thermal response to betel chewing.

In a preliminary study using carotid Doppler to measure blood flow of the carotid system plus measurements of blood pressure and heart rate in habitual, occasional and fresh chewers, blood flow was significantly increased during betel quid chewing only in the external and common carotid arteries. This flow increase was associated with facial flush sensation. Heart rate was prominently increased, especially in fresh and occasional chewers, and associated with palpitation.

*Autonomic functions*

To investigate further the involvement of the autonomic nervous system on the effects of betel chewing, two autonomic function tests were studied before and during betel quid chewing.<sup>20,21</sup> One was the sympathetic skin response (SSR) which is a psychophysical response mediated by the central and peripheral sympathetic pathways.<sup>22</sup> Another was the RR interval variation (RRIV) which depends partly on the parasympathetic reflex mediated by the vagus nerve.<sup>22</sup>

SSR was recorded from the hand by stimulation of the contralateral median nerve at the wrist.<sup>20</sup> While the response latency remained unchanged, the response amplitude showed a progressive reduction during chewing and a gradual recovery after chewing. The altered response was similar to that seen in palmar hyperhidrosis,<sup>23</sup> suggesting the activation of sympathetic pathways.

In the RRIV test, when one or two betel quids were consumed, the main effect was a cardio-acceleratory response.<sup>21</sup> With increasing consumption of betel quids, there was a reduction in RRIV, particularly during deep breathing. Consumption of betel nut only or chewing gum had no effects on RRIV. The dose-dependent responses suggest that usual consumption of one or two betel quids cause mainly a sympathetic activation while heavy consumption will affect parasympathetic function.

*Sympathoadrenal response*

To investigate further the sympathetic involvement in the effect of betel quid chewing, plasma concentrations of adrenaline, noradrenaline and dopamine were measured before and during chewing in two groups of betel quid and piper betel flower only, respectively.<sup>24</sup> Betel quid chewing caused a significant elevation in the concentrations of noradrenaline and adrenaline while piper betel flower chewing caused a moderate increase in noradrenaline without reaching statistical significance ( $p = 0.06074$ ). It is generally believed that plasma noradrenaline concentration is an index of sympathetic nervous system activity, while adrenaline level is a response to sympathetic activation.<sup>25</sup> Therefore, the data suggest that betel quid chewing activates a sympathoadrenal response.

*Comments and conclusions*

Several claimed effects of betel quid chewing have been confirmed by objective psychophysiological or neurophysiological experiments. These effects include palpitation, sweating, a warm sensation of the body and face and heightened alertness. These studies demonstrated further that the effects of betel quid chewing was fast, with onset within 2 minutes after chewing, and reaching the maximal within 4-6 minutes, suggesting that active compounds released from betel quid chewing are absorbed mainly in the oral cavity, most probably through the mucous membrane, to account for the rapid onset.

It is interesting to note that the effects of betel quid chewing are habit-related and dose-dependent. The effects of betel quid chewing are stronger for fresh or occasional chewers than for habitual chewers, suggesting that tolerance or habituation also occurs in betel quid use. In RRIV study, consumption of one or two betel quids caused mainly a sympathetic activation while continued consumption of more than two betel quids showed a parasympathetic activation, thus indicating dose-related responses.

It was often difficult to be certain whether the sites of observed effects were peripheral or central. Although the cardio-acceleratory response may indicate peripheral sympathetic activation, it might be due to a central effect. Intravenous or subcutaneous administration of arecoline in human subjects, who were pretreated with a peripheral cholinergic blocker, caused a cardio-acceleratory response in all studies, and a pressor response in some.<sup>7-10</sup> These findings suggest that arecoline exerts a central cholinergic mechanism which then activates a descending sympathetic effect. In animal studies, arecoline has been shown to induce an arousal and EEG desynchronization, similar to the actions of ACh or by stimulation of the reticular activating system.<sup>5,11</sup>

On the other hand, arecoline and arecaidine from areca nut and several phenolic compounds from piper betel flower are found to be stimulators of catecholamine release from chromaffin cells *in vitro*.<sup>14,15</sup> Thus, the sympathetic effect of betel quid chewing may be due partly to the sympathetic actions of those alkaloids and phenolic compounds. Although betel quid chewing caused an elevation in the plasma concentrations of adrenaline and noradrenaline,<sup>24</sup> the sites of activation could not be decided.

As the plasma level of noradrenaline is believed to be an index of sympathetic nervous system activity while the adrenaline level is a response to sympathetic activation,<sup>25</sup> betel quid chewing may lead to a mobilized state similar to activation of the sympathoadrenal axis, which plays an important role in the adaptive preparation of the organism in emotional or stressful situations. This effect may partly explain the facts that betel quid chewing may reduce hunger and fatigue and increase the capacity for work.

Although arousal has been shown to be mediated by central cholinergic mechanisms, adrenergic drugs such as amphetamine are also capable of producing arousal.<sup>26</sup> The finding that the hyperthermic response from betel quid chewing was abolished by atropine and partly inhibited by propranolol suggests that there may be central and peripheral activations of sympathetic system.

In conclusion, the main effects of betel quid chewing appear to act upon the central and autonomic nervous systems although the sites and modes of these actions still remain poorly understood. These studies have confirmed some of the effects claimed by betel quid users, but further studies are required to determine more precisely the respective roles played by central and autonomic nervous systems and the individual pharmacological effects of the components of the betel quid mixture.

#### References

- Burton-Bradley BG. Arecaidinism. Betel chewing in transcultural perspective. *Can J Psychiatry* 1979;24:481-8.
- Cawte J. Psychoactive substances of the South Seas: betel, kava and pituri. *Aust NZ J Psychiatry* 1985;19:83-7.
- Chu NS, Chang CF. On the culture of betel chewing in Taiwan. *Evergreen Monthly* 1994;130:78-81 [in Chinese].
- Nieschulz O. Zur Pharmacologie der Wirkstoffes des Betels. *Arzneim-Forsch* 1970;2:218-29.
- Taylor P. Cholinergic agonists. In: Gilman AG, Goodman LS, Gilman A, editors. *The pharmacological basis of therapeutics*, 6th edn. New York, Macmillan; 1980, pp. 91-9.
- Von Euler US, Domeij B. Nicotine-like actions of arecoline. *Acta Pharmacol* 1945;1:263-9.
- Abramson LB, Brown AJ, Sitaram N. A cardioacceleratory response to low-dose arecoline infusion during sleep in patients with major depression disorder: relationship to REM sleep induction. *Psychiatr Res* 1985;19:189-98.
- Christie JE, Shering A, Ferguson J, Glen AIM. Physostigmine and arecoline: effects of intravenous infusions in Alzheimer presenile dementia. *Br J Psychiatry* 1981;138:46-50.
- Nurnberger JI, Jimerson DC, Simmons-Alling S *et al.* Behavioral, physiological, and neuroendocrine responses to arecoline in normal twins and "well state" bipolar patients. *Psychiatr Res* 1983;9:191-200.
- Nutt JG, Rosin A, Chase TN. Treatment of Huntington disease with a cholinergic agonist. *Neurology* 1978;28:1061-4.
- Rinaldi F, Himwich HE. Alerting responses and actions of atropine and cholinergic drugs. *Arch Neurol Psychiatry* 1955;73:387-95.
- Johnston GAR, Krogsgaard-Larsen P, Stephanson A. Betel nut constituents as inhibitors of  $\gamma$ -aminobutyric acid uptake. *Nature* 1975;258:627-8.
- Lodge D, Johnston GAR, Curtis DR, Brand SJ. Effects of the areca nut constituents arecaidine and guvacine on the action of GABA in the cat central nervous system. *Brain Res* 1977;136:513-22.
- Huang LS, Wang CK, Sheu MJ, Kao LS. Phenolic compounds of Piper betle flower as flavoring and neuronal activity modulating agents. In: Ho CT, Lee CY, Huang MT, editors. *Phenolic compounds in food and their effects on health*. American Chemical Society Series 1992;506:200-13.
- Wang CK, Hwang LS. Effects of betel quid on catecholamine secretion from adrenal chromaffin cells. *Proc Natl Sci Council ROC, part B* 1997;21:129-36.
- Chu NS. Cardiovascular responses to betel chewing. *J Formos Med Assoc* 1993;92:835-7.
- Chu NS. Effect of betel chewing on performance reaction time. *J Formos Med Assoc* 1994;93:343-5.
- Chu NS. Effects of betel chewing on electroencephalographic activity: spectral analysis and topographic mapping. *J Formos Med Assoc* 1994;93:167-9.
- Chu NS. Betel chewing increases the skin temperature: effects of atropine and propranolol. *Neurosci Lett* 1995;194:130-2.
- Chu NS. Sympathetic skin responses to betel chewing. *J Formos Med Assoc* 1994;93:260-2.
- Chu NS. Effect of betel chewing on RR interval variation. *J Formos Med Assoc* 1995;94:106-10.
- Shahani BT, Day TJ, Cros D, Khalil N, Kneebone CS. RR interval variation and the sympathetic skin response in the assessment of autonomic function in peripheral neuropathy. *Arch Neurol* 1990;47:659-64.
- Chu EC, Chu NS. Patterns of sympathetic skin response in palmar hyperhidrosis. *Clin Auton Res* 1997;7:1-4.
- Chu NS. Sympathetic response to betel chewing. *J Psychoact Drugs* 1995;27:183-6.
- Mathias CJ, Christensen NJ, Corbett JL, Frankel HL, Spalding JM. Plasma catecholamines during paroxysmal neurogenic hypertension in quadruplegic man. *Circ Res* 1976;39:204-8.
- Low MD. Psychology, psychophysiology, and the EEG. In: Niedermeyer E, Lopes da Silva F, editors. *Electroencephalography*, edn 2. Baltimore: Urban & Schwarzenberg; 1987, pp. 541-8.

HP98  
h

# Effects of Betel Chewing on the Central and Autonomic Nervous Systems

Nai-Shin Chu

Department of Neurology, Chang Gung Medical College and Memorial Hospital, Taipei, Taiwan, ROC

Address of Corresponding Author

*Journal of Biomedical Science* 2001;8:229-236 (DOI: 10.1159/000054038)

### Key Words,

- Betel nut
- Betel nut chewing
- Central nervous system
- Autonomic nervous system
- Addiction

### Abstract

Betel chewing has been claimed to produce a sense of well-being, euphoria, heightened alertness, sweating, salivation, a hot sensation in the body and increased capacity to work. Betel chewing also leads to habituation, addiction and withdrawal. However, the mechanisms underlying these effects remain poorly understood. Arecoline, the major alkaloid of Areca nut, has been extensively studied, and several effects of betel chewing are thought to be related to the actions of this parasympathomimetic constituent. However, betel chewing may produce complex reactions and interactions. In the presence of lime, arecoline and guvacolone in Areca nut are hydrolyzed into arecaidine and guvacine, respectively, which are strong inhibitors of GABA uptake. *Piper betle* flower or leaf contains aromatic phenolic compounds which have been found to stimulate the release of catecholamines in vitro. Thus, betel chewing may affect parasympathetic, GABAergic and sympathetic functions. Betel chewing produces an increase in heart rate, blood pressure, sweating and body temperature. In addition, EEG shows widespread cortical desynchronization indicating a state of arousal. In autonomic function tests, both the sympathetic skin response and RR interval variation are affected. Betel chewing also increases plasma concentrations of norepinephrine and epinephrine. These results suggest that betel chewing mainly affects the central and autonomic nervous systems. Future studies should investigate both the acute and chronic effects of betel chewing. Such studies may further elucidate the psychoactive mechanisms responsible for the undiminished popularity of betel chewing since antiquity.

1199  
 ✓

## Case-Control Study of Meige's Syndrome

### Result of a Pilot Study

M. Behari<sup>a</sup>, A.K. Sharma<sup>a</sup>, S. Changkakoti<sup>a</sup>, N. Sharma<sup>a</sup>, R.M. Pandey<sup>b</sup>

Departments of

<sup>a</sup>Neurology and

<sup>b</sup>Bio-Statistics, All India Institute of Medical Sciences, New Delhi, India

#### Address of Corresponding Author

*Neuroepidemiology* 2000;19:275-280 (DOI: 10.1159/000026265)

#### Key Words

- Risk factors
- Focal dystonia
- Blepharospasm
- Etiology
- Betel nut
- Tobacco

#### Abstract

A pilot case-control study was conducted to identify possible risk factors for Meige's syndrome. Patients with Meige's syndrome and age- and sex-matched controls suffering from other neurological diseases were recruited from the Movement Disorders Clinic and Neurology Outpatient Department of the All India Institute of Medical Sciences. All participants were interviewed and information regarding psychiatric and medical illnesses, use of medications, exposure to fumes, dust and pets, characteristics such as marital status, socio-economic status, alcohol, tea/coffee use, tobacco use, betel nut chewing and family history of neurodegenerative diseases among first-degree relatives was ascertained. We found that betel nut with tobacco chewing was a significant predictor for Meige's syndrome (adjusted odds ratio 7.4, 95% confidence interval = 1.0-59.82). The role of local irritation or the effect of some chemicals in tobacco and betel nuts needs further evaluation of the pathogenesis of Meige's syndrome.

## CASE REPORT

# Betel nut indulgence as a cause of epilepsy

ZHILING HUANG<sup>†</sup>, BO XIAO<sup>‡</sup>, XIAOQING WANG<sup>†</sup>, YOUYUAN LI<sup>†</sup> & HONGBO DENG<sup>†</sup>

<sup>†</sup>Department of Geriatric Neurology, Xiangya Second Hospital, Central South University, Changsha, Hunan 410011, PR China; <sup>‡</sup>Institute of Neurology, Xiangya Hospital, Central South University, Changsha, Hunan 410008, PR China

Correspondence to: Dr ZhiLing Huang, M.D., Ph.D., Department of Geriatric Neurology, Xiangya Second Hospital, Central South University, Changsha, Hunan 410011, PR China. E-mail: hz11118@sohu.com

We report a 29-year-old man with secondarily generalised seizure and cardiac impairment. He was an indulger in betel nuts without other aetiological or precipitating factors, and no abnormality on neuroradiologic investigation. The occurrence of his seizures related to an overdose of betel nuts. It is clinically important to know that epilepsy may be induced by betel nut chewing.

© 2003 BEA Trading Ltd. Published by Elsevier Science Ltd. All rights reserved.

*Key words:* betel nut; epilepsy; aetiology.

## INTRODUCTION

It has been estimated that more than 10% of the world's population chew betel nut for its mild psychoactive effects<sup>1</sup>. However, significant illness can be associated with betel nut, including asthma exacerbation, cholinergic crises, cardiac arrhythmias, acute psychosis, milk-alkali syndrome and oropharyngeal tumours<sup>2</sup>. Betel chewing also leads to habituation, addiction and withdrawal symptoms. We describe an adult patient who had epilepsy associated with indulgence in betel nuts. Here, we report on the patient and emphasise the clinical importance of recognising the convulsion-inducing effects of betel nut.

## CASE REPORT

A 29-year-old postgraduate student was referred with four secondarily generalised seizures which occurred within a period of 1 week. He was born after an uncomplicated pregnancy with normal birth weight and head size. He was in good health before the first convulsion. There was no history of intracranial infec-

tion, febrile seizures, head trauma or a family history of seizures. No precipitating factors, such as sleep deprivation, alcohol consumption or mental stress, could be identified for any of the seizures. However, he was an indulger in betel nuts. This betel nut chewing began at the age of 7. From the age of 18, he would chew over 10 nuts per day. He claimed that betel nut chewing produced a sense of euphoria, heightened alertness, sweating, salivation, a hot sensation in the body and an increased capacity to work. Betel nut chewing amounted to 20 per day 3 weeks before his first episode. Palpitations occurred frequently. On the day of his first seizure, he chewed about 20 nuts between 8:00 and 13:00 hours, which equalled his usual daily consumption. All seizures happened in the afternoon. In the first episode, he had a sudden feeling of numbness on the left side of his face, just after a siesta. He could recall no other symptoms, and his next memory was of himself lying on his bed. Two hours later, the second episode occurred with the same aura, he then lost consciousness and suffered a generalised convulsive seizure, witnessed by his mother. About 10 minutes later, consciousness returned. Then he was transferred to our department in an ambulance. Oral

leukoplakia and blackened teeth were found. Pulse rate was 120 per minute, but irregular. No neurological abnormality was found. Results of routine blood and cerebrospinal fluid (CSF) examination, computed tomography (CT) scan, magnetic resonance imaging (MRI), MR angiography of the brain, and cardiac ultrasound were all normal. ECG monitoring showed a paroxysmal supraventricular tachycardia. Blood creatine phosphokinase (CK) was 460 U/l (normal values, 24–195 U/l). Interictal electroencephalography (EEG) showed spike and wave activity in the right temporal region on day 1, but was normal on day 4. Interictal SPECT showed a localised diminution of cerebral blood flow in the right temporal lobe. Because he had experienced two seizures in one day, Carbamazepine (CBZ), 100 mg t.i.d., was administered to prevent further convulsions. Due to lack of previous evidence that betel nut use might cause convulsions, abstinence from it was not asked for, but his mother was told to note the consumption of betel nuts, which was 8, 10, 16, 17, 22 and 25 on days 2, 3, 4, 5, 6 and 7, respectively. The third and fourth attacks, identical to the second attacks in every respect, occurred on day 7. During the fourth attack, an ictal EEG showed spike and wave activity in the right temporal region. Thus, excessive betel nut chewing was suspected to be the cause of his seizures. Abstinence from betel nuts was suggested plus administration of CBZ as previously. He stopped taking the medication 1 day after starting his abstinence, because of marked daytime sleepiness. Seven days after abstinence started results of CK, ECG, EEG and cerebral SPECT re-examination were normal. EEGs were repeatedly taken but were found to be normal, and there has been no recurrence of convulsions over the next 2 years of follow-up, even without medication. Thus, it appears that he does not have irreversible brain lesions, but that his epilepsy was induced by the excessive consumption of betel nuts, because repeated EEG examination disclosed no paroxysmal activity since he became abstinent. In addition, his neuroradiologic findings were normal and he had no previously reported aetiological factors for epilepsy.

## DISCUSSION

Betel nut chewing is widespread. Most betel nut-related effects are transient and mild in nature. Nevertheless, betel nut chewing can produce significant cholinergic, neurological, cardiovascular and gastrointestinal manifestations.

The effects of betel nut chewing on the heart results in cardioacceleratory responses, reduction of RR interval variation<sup>3</sup>, cardiac dysrhythmias (e.g. paroxysmal supraventricular tachycardia)<sup>4</sup> and even acute myocardial infarction<sup>5</sup>. The reversible abnormalities

of CK and ECG in our patient may be betel-related events.

It has been described that betel chewing causes widespread cortical desynchronisation of the EEG, indicating a state of arousal<sup>6</sup>. A betel nut-induced extrapyramidal syndrome has been reported<sup>7</sup>. However, at present, few physicians know about the convulsion-inducing effects of betel nuts. The pathophysiological mechanisms underlying the convulsion-inducing effects of betel nut still remain undetermined. The convulsion-inducing effect of betel nuts in this case is strongly inferred by the timing of the attacks in relation to the excessive betel nut chewing, full recovery without medication since abstinence, the absence of other aetiological or precipitating factors, and the nature of the stereotyped ictal symptoms. Excessive betel nut chewing may produce complex reactions and interactions. (1) Arecoline, the major alkaloid of the Areca nut, a parasympathomimetic constituent, might overactivate the muscarinic receptor<sup>8</sup>. Unfortunately, arecoline concentration in blood and CSF were not determined in our patient; (2) Betel chewing can increase plasma concentrations of norepinephrine and epinephrine<sup>9</sup>; (3) A large quantity of betel nuts, including their alkaline calcium salts, can cause hypercalcaemia, hypokalaemia and metabolic alkalosis<sup>10</sup>. (4) Gamma-aminobutyric acid (GABA), the principal inhibitory neurotransmitter in the cerebral cortex, maintains the inhibitory tone that counterbalances neuronal excitation. When this balance is perturbed, seizures may ensue<sup>11</sup>. In the presence of lime, arecoline and guvacoline in the Areca nut are hydrolysed into arecaidine and guvacine, respectively, which are strong inhibitors of GABA uptake<sup>9</sup>. Persistent interference with GABAergic system might result in neurological disturbance. All of these possibilities would lead to the convulsion-inducing effect of betel nut.

To conclude, indulgence in betel nut can be considered possible cause of epilepsy. It is clinically important to know that epilepsy may be induced by betel nut chewing. The profile of this patient includes: indulgence in betel nuts, multiorgan involvement, absence of other aetiological or precipitating factors, normality of neuroradiologic findings and secondary generalisation. Given this set of findings, betel nut-related epilepsy is suggested. However, information from new cases will help to define the entity more exactly.

## REFERENCES

1. Yoganathan, P. Betel chewing creeps into the New World. *The New Zealand Dental Journal* 2002; **98**: 40–45.
2. Nelson, B. S. and Heischouer, B. Betel nut: a common drug used by naturalized citizens from India, Far East Asia, and the South Pacific Islands. *Annals of Emergency Medicine* 1999; **34**: 238–243.

3. Chu, N. S. Effect of betel chewing on RR interval variation. *Journal of the Formosan Medical Association* 1995; **94**: 106-110.
4. Chiang, W. T., Yang, C. C., Deng, J. F. and Bullard, M. Cardiac arrhythmia and betel nut chewing—is there a causal effect? *Veterinary and Human Toxicology* 1998; **40**: 287-289.
5. Deng, J. F., Ger, J., Tsai, W. J., Kao, W. F. and Yang, C. C. Acute toxicities of betel nut: rare but probably overlooked events. *Journal of Toxicology Clinical Toxicology* 2001; **39**: 355-360.
6. Chu, N. S. Effects of betel chewing on electroencephalographic activity: spectral analysis and topographic mapping. *Journal of the Formosan Medical Association* 1994; **93**: 167-169.
7. Deahl, M. Betel nut-induced extrapyramidal syndrome: an unusual drug interaction. *Movement Disorders* 1989; **4**: 330-332.
8. Soncrant, T. T., Holloway, H. W. and Rapoport, S. I. Arecoline-induced elevations of regional cerebral metabolism in the conscious rat. *Brain Research* 1985; **347**: 205-216.
9. Chu, N. S. Effects of betel chewing on the central and autonomic nervous systems. *Journal of Biomedical Science* 2001; **8**: 229-236.
10. Lin, S. H., Lin, Y. F., Cheema-Dhadli, S., Davids, M. R. and Halperin, M. L. Hypercalcaemia and metabolic alkalosis with betel nut chewing: emphasis on its integrative pathophysiology. *Nephrology, Dialysis, Transplantation* 2002; **17**: 708-714.
11. Treiman, D. M. GABAergic mechanisms in epilepsy. *Epilepsia* 2001; **42** (Suppl. 3): 8-12.

# Betel-quist use is associated with the risk of the metabolic syndrome in adults<sup>1-4</sup>

Jinn-Yuh Guh, Lea-Yea Chuang, and Hung-Chun Chen

## ABSTRACT

**Background:** Betel-quist use has been associated with obesity and hyperglycemia in previous studies.

**Objective:** The aim was to test whether betel-quist use contributes to the metabolic syndrome, as defined by the National Cholesterol Education Program Adult Treatment Panel III.

**Design:** Associations between betel-quist use and the metabolic syndrome, obesity, hypertriglycerolemia, low HDL cholesterol, hyperglycemia, and high blood pressure after adjustment for sex, age, smoking, alcohol drinking, physical activity, and dietary intakes were studied in nonpregnant adults aged 20-64 y (n = 1986) from the Nutrition and Health Survey in Taiwan (1993-1996).

**Results:** The prevalence of the metabolic syndrome was not significantly different between the men and women (10.1% compared with 9.7%), whereas the prevalence of betel-quist use was higher in the men than in the women (31% compared with 2.3%; P < 0.001). The daily rate of betel-quist use was associated with the metabolic syndrome [odds ratio (OR) associated with a betel-quist consumption rate of 10 times/d: 1.31; 95% CI: 1.12, 1.55; P = 0.003], abdominal obesity (OR: 1.42; 95% CI: 1.2, 1.7; P = 0.001), hypertriglycerolemia (OR: 1.33; 95% CI: 1.02, 1.73; P = 0.037), and high blood pressure (OR: 1.2; 95% CI: 1.01, 1.4; P = 0.04). However, the daily rate of betel-quist use was not associated with low HDL cholesterol or hyperglycemia.

**Conclusion:** The daily rate of betel-quist use is independently and positively associated with the metabolic syndrome in adults. *Am J Clin Nutr* 2006;83:1313-20.

**KEY WORDS** Betel quid, metabolic syndrome, hyperglycemia, hypertension, obesity, hyperlipidemia

## INTRODUCTION

Betel-quist use, the fourth most addictive habit in the world after nicotine, ethanol, and caffeine use, occurs in ≈10% of the world population, including that of Taiwan. Betel quid (*Areca catechu*) is usually chewed in combination with Piper betle leaf and lime, and the most abundant arecal alkaloid found in betel quids is arecoline, a parasympathomimetic agent that lowers blood pressure (BP) (1, 2). However, other arecal compounds are sympathomimetic substances that increase BP (3), and hypertension is part of the National Cholesterol Education Program Adult Treatment Panel III definition of the metabolic syndrome (4, 5).

Betel-quist use is associated with an increased risk of oral cancer, liver cirrhosis, and hepatocellular carcinoma (1, 2, 6, 7).

Arecal nitrosamines have also been identified as carcinogens (8). Moreover, studies conducted in humans (8, 9) and mice (10) found that betel-quist use was associated with abdominal obesity and hyperglycemia, 2 components of the metabolic syndrome. Thus, it is of interest to determine whether associations between betel-quist use and the metabolic syndrome exist. Therefore, data from the stratified multistage probability sampled Nutrition and Health Survey in Taiwan (NAHSIT, 1993-1996) (11) was used to address 2 questions. First, is betel-quist use independently associated with the metabolic syndrome? Second, is betel-quist use independently associated with all 5 components used to define the metabolic syndrome?

## SUBJECTS AND METHODS

### Study population

The Taiwanese population was ≈21 million in 1993-1996. The design and operation of NAHSIT was described elsewhere (12). Briefly, Taiwan was stratified into 7 strata, and 3 townships in each stratum were selected with the selection probability proportional to the population size of the townships. A total of 9961 persons aged 4-96 y were sampled (sampling rate: 0.047%). All NAHSIT enrollees signed the informed consent.

The present study was approved by the Kaohsiung Medical University ethics committee. Because 24-h dietary recall questionnaires were only administered to participants aged 13-64 y, the target population was adults aged 20-64 y. Thus, inclusion criteria were the following: nonpregnant adults aged 20-64 y (n = 3910). Exclusion criteria were the following: not receiving physical examination or phlebotomy (n = 1454), fasting <8 h or hemolyzed blood (n = 250), missing personal history (diabetes

<sup>1</sup> From the Departments of Internal Medicine (J-YG and H-CC) and Biochemistry (L-YC), Kaohsiung Medical University, Kaohsiung, Taiwan.

<sup>2</sup> The Nutrition and Health Survey in Taiwan was sponsored by the Department of Health in Taiwan (DOH FN8202, DOH-83-FS-41, DOH-84-FS-11, DOH-85-FS-11, DOH-86-FS-11) and carried out by W-H Pan (Institute of Biomedical Sciences, Academia Sinica) and P-C Huang (Department of Biochemistry, National Taiwan University). The views expressed herein are solely those of the authors.

<sup>3</sup> Supported by grant no. DOH93-TD-D-113-021(2) from the Department of Health, Taiwan, ROC.

<sup>4</sup> Address reprint requests to H-C Chen, Department of Internal Medicine, Kaohsiung Medical University, 100 Zhiyou 1st Road, Kaohsiung, Taiwan 807, ROC. E-mail: jiyugu@kmu.edu.tw.

Received September 22, 2005.

Accepted for publication February 28, 2006.

Handwritten: 1204

The American Journal of Clinical Nutrition



mellitus [DM], hypertension, smoking, alcohol drinking, betel-quid use, or physical activity;  $n = 115$ ), missing dietary intake data ( $n = 133$ ), or missing concentrations of blood glucose, plasma triacylglycerol, or HDL cholesterol ( $n = 205$ ). Note that some NAHSIT participants met more than one exclusion criteria. Thus, data from 1986 persons were included in the study.

### Interview

A household interview and physical examination were completed by technicians who received a 1-wk training course (12). Dietary intakes for those aged 20–64 y were estimated from 24-h dietary recalls and food-frequency questionnaires. The 24-h dietary recall (13, 14) included a recall of foods consumed within the 24 h before administering the 24-h dietary recall questionnaires. Nutrient intakes were calculated from each food item based on the Nutrient Composition Data Bank for Foods of Taiwan Area (15). The food-frequency questionnaire (16, 17) estimated the frequency of intake of 36 food items for 1 mo. The 24-h dietary recall and food-frequency questionnaire were validated by 2 previous studies with the use of an external dataset. These adults were interviewed every 3 mo at which time they were given a food-frequency questionnaire and asked to record their diets for the next 5 d. The 5 d included 3 weekdays and 2 weekend days. Data from 49 men and 20 women who had 2 or 3 interviews and 5-d dietary records within 6 mo were used (18, 19).

The question asked to ascertain betel-quid use was "how often do you chew betel quid (per day or per week)?" From the 368 betel-quid users, 216 reported use in times/d. The other 152 reported use in times/wk, which was converted to times/d. The frequency of betel-quid use was asked again in a different part of the interview to ensure accuracy. Note that the duration of betel-quid use was not asked. The questions to ascertain smoking status were the following: "are you currently smoking?", "at what age did you start smoking?", and "on average, how many packs do you smoke each day?" Smoking was then converted to pack-years. The questions to ascertain alcohol consumption were the following: "are you currently drinking alcohol?", "at what age did you start to drink alcohol?", and "on average, how often do you drink?" Alcohol consumption was then converted to drink-years. The question asked to ascertain the presence of DM was, "have you been diagnosed as having DM (also called 'a disease with sugar in urine' in lay terms) by a physician?" The question asked to ascertain the presence of hypertension was, "have you been diagnosed as having hypertension (also called 'high blood pressure' in lay terms) by a physician?"

Physical activity was assessed by the frequency of activity per week within 1 mo; activities included biking, ball games, gymnastics or boxing, swimming, dancing, mountain climbing, jogging, walking, gardening, housework, moving or loading objects, and mechanical assembling (20). Note that because physical activity was a composite score of several different physical activities, we classified physical activity as into 5 categories (0,  $\leq 3$ ,  $> 3$  and  $\leq 7$ ,  $> 7$  and  $\leq 9$ , or  $> 9$  times/wk).

Body weight was measured to the nearest 0.1 kg with the use of a weighing scale while the participants wore light clothing (20). The scale was calibrated with a 20-kg counterweight before each measurement. Body height was measured to the nearest 0.1 cm with the use of a wall-glued metal measuring tape and an acute-angled head piece while the participants stood against a plumb-checked vertical wall and wore no shoes. Body mass

index was calculated as weight (in kg)/height<sup>2</sup> (in m). Waist circumferences were measured horizontally with a soft measuring tape at the level of the natural waist, which was identified as the level at the hollow molding of the trunk when the participants bent their trunks laterally (21). The participants were told to avoid smoking for  $\geq 30$  min before measuring BP, which was measured with the use of mercury sphygmomanometers after the participants had rested for 5 min in a supine position (22). Systolic BP (SBP) and diastolic BP (DBP) were recorded as the first and fifth phase of Korotkoff sound, respectively. Two BP measurements were made 30 s apart. If the 2 measurements differed by  $> 10$  mm Hg, a third measurement was made and the 2 closest BPs were averaged. The weighing scale, measuring tapes, and mercury sphygmomanometer were standardized by Bureau of Standards, Metrology, and Inspection-authorized agencies at the start of the study and at 6-mo intervals.

The metabolic syndrome was defined by abnormalities in  $\geq 3$  of the following criteria, which were modified from the National Cholesterol Education Program Adult Treatment Panel III criteria (4, 5): 1) abdominal obesity, defined as a waist circumference  $> 90$  cm for men and  $> 80$  cm for women (23, 24); 2) hypertriglycerolemia, defined as triacylglycerol concentrations  $\geq 150$  mg/dL; 3) low HDL-cholesterol concentrations, defined as an HDL-cholesterol concentration  $< 40$  mg/dL in men and  $< 50$  mg/dL in women; 4) hyperglycemia, defined as a fasting whole-blood glucose concentration  $\geq 100$  mg/dL (5.6 mmol/L) or DM [ie, fasting blood glucose  $\geq 110$  mg/dL (6.1 mmol/L), physician-diagnosed DM, or treated DM] (25); and 5) high BP, defined as SBP  $\geq 130$  mm Hg, DBP  $\geq 85$  mm Hg, or physician-diagnosed or treated hypertension. Note that the National Cholesterol Education Program Adult Treatment Panel III was ambiguous about treated hypertensive or diabetic patients who may have normal blood pressure or fasting blood glucose concentrations. Therefore, we adopted the above definitions of high blood pressure and hyperglycemia as defined by the International Diabetes Federation and used by previous studies (23, 24).

### Analytic procedures

Fasting ( $\geq 8$  h) morning blood samples were drawn and centrifuged at  $1000 \times g$  for 15 min at 4 °C on site. Venous whole-blood glucose was measured immediately by the glucose oxidase method with a glucose analyzer (model 23A; YSI, Yellow Springs, OH) in blood that was collected into sodium fluoride tubes (21, 22). Serum was stored in a single batch at  $-70$  °C until analyzed within 1 mo for triacylglycerol and HDL cholesterol with the use of a Hitachi 747 autoanalyzer (Hitachi, Tokyo, Japan) (26).

### Statistical analysis

The statistical package STATA version 8.2 (Stata Corp, College Station, TX) was used. Data were expressed as means ( $\pm$  SEMs). Triacylglycerol, HDL cholesterol, and fasting blood glucose were log-transformed before analyses to normalize the distribution. Statistical significance was defined as a  $P$  value of  $< 0.05$ .

The weighted "svy (svyreg: linear regression; svylogit: logistic regression)" or "robust" command was used to account for the complex survey design in NAHSIT. Differences between continuous variables and categorical variables were tested with unpaired  $t$  tests and chi-square tests, respectively. The effect of



betel-quad use was examined in multiple linear or logistic regression analyses after adjustment for sex, age, smoking, alcohol drinking, dietary intakes, and physical activity. The above 2 statistical analyses were used to test for the effects of betel-quad use as a continuous or categorical variable.

An overall test for the effect of betel-quad use was performed with the *F* test, whereas linear trend tests for the effect of betel-quad use category (an ordinal independent variable) were performed by using orthogonal polynomial contrasts (with computer-generated contrast coefficients) (27) in multiple linear or logistic regression analyses. We also tested for the interaction of sex or age with betel-quad use in multiple linear regression and logistic regression analyses.

Note that the orthogonal polynomial contrast is a technique used for multiple comparisons (28). A contrast is a linear combination of 2 or more means with coefficients that sum to zero. Two contrasts are orthogonal (nonredundant and independent) if the sum of the products of corresponding coefficients (ie, coefficients for the same means) adds to zero. For *J* groups, we can only construct *J*-1 orthogonal contrasts. Trend analysis is performed when the category has a natural order. In polynomial regression, the model of the sample mean consists of coefficient terms: linear, quadratic, cubic, etc. A polynomial contrast is a set of contrasts evaluating trends: linear, quadratic, cubic, etc. Two polynomial contrasts are orthogonal if the sum of the products of corresponding coefficients adds to zero. Thus, we have 2 contrasts (evaluating linear and quadratic trends), which are orthogonal, for the 3 betel-quad use categories.

## RESULTS

### Demographic characteristics of NAHSIT enrollees who did or did not participate

The participation rate was 51% (1986 of 3910). A lower percentage of men was observed in the participants subgroup than in the nonparticipants subgroup (47% compared with 56%, *P* = 0.003). Thus, data were analyzed separately for men and women. Moreover, the participants were older than were the nonparticipants in both the male group [ $\bar{x}$  ( $\pm$ SEM) age: 40  $\pm$  0.4 compared with 37  $\pm$  0.4 y, respectively; *P* < 0.001] and the female group (39  $\pm$  0.4 compared with 37  $\pm$  0.5 y, respectively; *P* = 0.02). Thus, age was included as an adjustment factor in the multiple linear and logistic regression analyses where the interaction between age and betel-quad use was also assessed for the participants.

In contrast, no significant differences in smoking, alcohol drinking, physical activity, and betel-quad use were observed between the participants and nonparticipants. Note that the metabolic syndrome, laboratory measurements, and dietary intakes cannot be compared between the participants and nonparticipants.

### Prevalence of betel-quad use in NAHSIT participants

The overall prevalence of betel-quad use was 15.9%, which was higher in the 920 men than in the 1066 women (31% compared with 2.3%, respectively; *P* < 0.001). In betel-quad users, the median frequency of betel-quad use was 3.5 times/d (first quartile: 0.33 times/d; third quartile: 10 times/d). Thus, the daily rate of betel-quad use was classified into none, low ( $\leq$  3.5 times/d), and high ( $>$  3.5 times/d) categories. Moreover, among the risk

factors and components of the metabolic syndrome, significant sex-by-tertile of betel-quad use interactions for body mass index, alcohol drinking, SBP, DBP, high BP, and dietary intakes of carbohydrates and vegetables were observed. Thus, demographic and laboratory characteristics of the participants were reported separately for the men and women.

### Demographic and laboratory characteristics of NAHSIT participants by categories of betel use

The findings for features of the metabolic syndrome and its risk factors are shown in Table 1 by categories of betel-quad use. Note that there was a linear trend with increasing smoking, alcohol drinking, and triacylglycerol and with decreasing age and fruit intake across increasing betel-quad use categories. In contrast, there was a linear trend with increasing SBP, DBP, and body mass index and with decreasing carbohydrate intake across increasing betel-quad use categories only in the women.

Note that the apparent number of women chewers was only 25 (1066  $\times$  2.3%). However, the prevalence of betel-quad chewing for the women (2.3%) was a weighted estimate. Thus, the actual number of women chewers was 82 (*n* = 32 in the low group and 50 in the high group), and the crude prevalence of betel-quad chewing for the women was 7.7% (*n* = 82 of 1066).

### Sex-specific demographic characteristics in the participants with or without the metabolic syndrome

The overall prevalence of the metabolic syndrome was 9.9% (10.1% for the men compared with 9.7% for the women, *P* = 0.86). Moreover, a logistic regression analysis showed that the prevalence of the metabolic syndrome increased with age in both sexes [odds ratio (OR) associated with 10-y increase in age: 1.008; 95% CI: 1.005, 1.01; *P* < 0.001]. Note that the women with the metabolic syndrome ate less fruit and were less likely to drink or exercise than women without the metabolic syndrome (data not shown). These relations were not observed in the men. In contrast, no significant differences for any other dietary factors were observed in both sexes (data not shown).

### Prevalence of risk factors and the 5 components of the metabolic syndrome in NAHSIT participants

The sex-specific prevalence of the risk factors and the 5 components used to define the metabolic syndrome in the present study are shown in Table 2. The prevalence of smoking, alcohol drinking, and high BP was higher in the men than in the women. Conversely, the prevalence of abdominal obesity, low HDL-cholesterol, and hyperglycemia was higher in the women than in the men, whereas physical activity and the prevalence of hypertriacylglycerolemia were not significantly different between the men and women.

### Betel-quad use category as a risk factor for each of the 5 components used to define the metabolic syndrome

In the above univariate analyses, the association between betel-quad use and the metabolic syndrome was confounded by the imbalances of many risk factors between betel-quad users and nonusers. Thus, multivariate analyses were adjusted for other metabolic syndrome risk factors to ascertain the role of betel-quad use in the development of the metabolic syndrome. The results for the NAHSIT participants in whom the 5 components of metabolic syndrome were analyzed as continuous variables

**TABLE 1**  
Demographic and laboratory characteristics of the Nutrition and Health Survey in Taiwan participants by different betel-quin use categories<sup>1</sup>

	Betel-quin use			P for trend <sup>2</sup>
	None	Low ( $\leq 3.5$ times/d)	High ( $> 3.5$ times/d)	
Men (n)	634	145	141	—
Women (n)	984	32	50	—
Age (y)	38.5 $\pm$ 0.4 <sup>3</sup>	36 $\pm$ 4	34 $\pm$ 2	0.005
Smoking (pack-years)	2.3 $\pm$ 0.2	11 $\pm$ 2	13 $\pm$ 2	< 0.001
Drinking (drink-years) <sup>4</sup>				
Men	3 $\pm$ 0.4	4 $\pm$ 1.5	7 $\pm$ 1.7	0.04
Women	0.3 $\pm$ 0.1	0.7 $\pm$ 0.3	3.4 $\pm$ 0.3	< 0.001
Physical activity (times/wk)	5 $\pm$ 0.4	4 $\pm$ 2	3.9 $\pm$ 0.8	0.27
Metabolic syndrome (%)	9.8 $\pm$ 1	13.5 $\pm$ 4	8.3 $\pm$ 3	0.86
Glucose (mg/dL)	84.6 $\pm$ 1	83 $\pm$ 2	80 $\pm$ 1.5	0.16
Hyperglycemia (%)	5.6 $\pm$ 0.4	5.6 $\pm$ 2	4 $\pm$ 2	0.07
SBP (mm Hg) <sup>4</sup>				
Men	123 $\pm$ 1	121 $\pm$ 3	122 $\pm$ 1	0.48
Women	115 $\pm$ 1	117 $\pm$ 4	133 $\pm$ 2	< 0.001
DBP (mm Hg) <sup>4</sup>				
Men	80 $\pm$ 1	79 $\pm$ 3	82 $\pm$ 1	0.27
Women	73 $\pm$ 0.8	73.5 $\pm$ 7	91 $\pm$ 2	< 0.01
High blood pressure (%) <sup>4</sup>				
Men	42 $\pm$ 4	39 $\pm$ 7	53 $\pm$ 9	0.4
Women	24 $\pm$ 3	13 $\pm$ 9	86 $\pm$ 11	0.06
BMI (kg/m <sup>2</sup> ) <sup>4</sup>				
Men	23 $\pm$ 0.4	23 $\pm$ 0.9	23 $\pm$ 0.4	0.52
Women	23 $\pm$ 0.2	24 $\pm$ 1	26 $\pm$ 1	0.02
Waist circumference (cm)	77 $\pm$ 1	78 $\pm$ 4	79 $\pm$ 3	0.4
Abdominal obesity (%)	14 $\pm$ 2	8 $\pm$ 5	11 $\pm$ 4	0.7
Triacylglycerol (mg/dL)	110 $\pm$ 8	124 $\pm$ 11	164 $\pm$ 8	0.002
Hypertriacylglycerolemia (%)	16 $\pm$ 2	28 $\pm$ 4	25 $\pm$ 6	0.28
HDL cholesterol (mg/dL)	58 $\pm$ 2	56 $\pm$ 2	60 $\pm$ 3	0.12
Low HDL cholesterol (%)	28 $\pm$ 4	18 $\pm$ 4	15 $\pm$ 7	0.4
Carbohydrate intake (g/d) <sup>4</sup>				
Men	286 $\pm$ 6	296 $\pm$ 30	279 $\pm$ 15	0.87
Women	207 $\pm$ 6	148 $\pm$ 10	143 $\pm$ 18	0.002
Fat intake (g/d)	68 $\pm$ 4	88 $\pm$ 24	83 $\pm$ 8	0.18
Fiber intake (g/d)	5.2 $\pm$ 0.2	4.5 $\pm$ 1	4.3 $\pm$ 0.6	0.08
Vegetable intake (times/wk) <sup>4</sup>				
Men	26 $\pm$ 1	26 $\pm$ 3	23 $\pm$ 3	0.17
Women	28 $\pm$ 2	22 $\pm$ 8	36 $\pm$ 2	0.24
Fruit intake (times/wk)	7 $\pm$ 0.4	5.2 $\pm$ 1	3.4 $\pm$ 0.3	< 0.01

<sup>1</sup> n = 1986. SBP, systolic blood pressure; DBP, diastolic blood pressure. The data were reported separately for men and women for the dependent variables when there was a significant sex-by-tertile of betel-quin use interaction.

<sup>2</sup> The differences in continuous and categorical variables between different betel-quin use categories were tested by orthogonal polynomial contrasts in linear and logistic regression, respectively.

<sup>3</sup>  $\bar{x} \pm$  SEM (all such values).

<sup>4</sup> P < 0.05 for sex-by-tertile of betel-quin use interaction.

are shown in **Table 3**. A linear trend with increasing serum triacylglycerol was observed across increasing betel-quin use categories. In contrast, a linear trend with increasing waist circumference, SBP, and DBP across increasing betel-quin use categories was observed only in the women.

The results for the NAHSIT participants in whom the 5 components of the metabolic syndrome were analyzed as categorical variables are shown in **Table 4**. A linear trend with increasing prevalence of high BP across increasing betel-quin use categories was observed only in the women.

Note that no significant interaction between age and betel-quin use categories was observed (**Table 3** and **Table 4**). Namely, the

relation between betel-quin use categories and each of the 5 components of the metabolic syndrome did not differ significantly with age.

#### Daily rate of betel-quin use as a risk factor for each of the 5 components used to define the metabolic syndrome

The results for the NAHSIT participants in whom the daily rate of betel-quin use was analyzed as a continuous variable are shown in **Table 5**. The daily rate of betel-quin use was independently and positively associated with waist circumference, serum triacylglycerol, and SBP. Betel-quin use was also independently



TABLE 2

Sex-specific prevalence of the 5 components of the metabolic syndrome and characteristics of the risk factors in the Nutrition and Health Survey in Taiwan participants<sup>1</sup>

	Men (n = 920)	Women (n = 1066)	P <sup>2</sup>
Smoking (pack-years)	7.6 ± 0.4	0.14 ± 0.06	< 0.001
Drinking (drink-years)	3.5 ± 0.5	0.35 ± 0.1	< 0.001
Physical activity (times/wk)	5.0 ± 0.4	4.9 ± 0.2	0.88
Metabolic syndrome (%)	10 ± 1	9.7 ± 1	0.86
Abdominal obesity (%)	10.7 ± 2	19.3 ± 1	0.004
Hypertriglycerolemia (%)	20 ± 3	12 ± 2	0.06
Low HDL cholesterol (%)	21 ± 3	33 ± 3	0.015
High blood pressure (%)	44.9 ± 4	27.5 ± 3	< 0.001
Hyperglycemia (%)	5.3 ± 0.6	7.4 ± 0.4	0.012

<sup>1</sup> All values are  $\bar{x} \pm \text{SEM}$ . n = 1986.

<sup>2</sup> The differences in continuous and categorical variables between the men and women were tested by unpaired *t* tests and chi-square tests, respectively.

and positively associated with abdominal obesity, hypertriglycerolemia, and high BP, but not with low HDL cholesterol or hyperglycemia. Note that the size of the coefficient or OR of a continuous variable is dependent on the unit (29), which, in this case, was 10 times/d (the third quartile of betel-quit use).

No significant interaction between age and the daily rate of betel-quit use was observed. Namely, the relation between the daily rate of betel-quit use and each of the 5 components of the metabolic syndrome did not differ significantly with age.

**Betel-quit use category as a risk factor for the metabolic syndrome**

When betel-quit use was analyzed as a categorical variable, neither low nor high use categories were significantly associated with the metabolic syndrome for either sex. Additionally, there was no linear trend with increasing prevalence of metabolic

syndrome across increasing betel-quit use categories (Table 1). Moreover, there was no significant interaction between age and betel-quit use categories. Namely, the relation between betel-quit use category and metabolic syndrome did not differ significantly with age.

**Daily rate of betel-quit use as a risk factor for the metabolic syndrome**

When betel-quit use was analyzed as a continuous variable, the daily rate of betel-quit use was associated with the metabolic syndrome (OR associated with a rate of betel-quit consumption of 10 times/d: 1.31; 95% CI: 1.12, 1.55; *P* = 0.003) in both the men and women. However, there was no significant interaction between age and the daily rate of betel-quit use. Namely, the relation between the daily rate of betel-quit use and the metabolic syndrome did not differ significantly with age.

TABLE 3

Multiple linear regression analyses of betel-quit use categories as a risk factor for each of the 5 components of the metabolic syndrome<sup>1</sup>

	Coefficient	P for trend <sup>2</sup>
Waist circumference (cm) <sup>3</sup>		
Men	0.15 ± 0.36 <sup>4</sup>	0.68
Women	1.34 ± 0.5	0.024
ln Triacylglycerol (mg/dL)	0.06 ± 0.02	0.02
ln HDL cholesterol (mg/dL)	0.02 ± 0.02	0.21
SBP (mm Hg) <sup>3</sup>		
Men	-0.3 ± 0.7	0.65
Women	4.6 ± 1.0	< 0.001
DBP (mm Hg) <sup>3</sup>		
Men	0.75 ± 0.47	0.14
Women	3.8 ± 0.6	< 0.001
ln Glucose (mg/dL)	-0.004 ± 0.004	0.23

<sup>1</sup> n = 1986. The daily rate of betel-quit use was divided into 3 categories (none, low, or high). The effect of betel-quit use was adjusted for sex, age (y), smoking (pack-years), alcohol drinking (drink-years), dietary intakes, and physical activity. The data were reported separately for men and women for the dependent variables when there was a significant sex-by-tertile of betel-quit use interaction.

<sup>2</sup> The linear trends in the differences between the different betel-quit use categories were tested by linear orthogonal polynomial contrasts.

<sup>3</sup> *P* < 0.05 for the sex-by-tertile of betel-quit use interaction.

<sup>4</sup>  $\bar{x} \pm \text{SEM}$  (all such values).

TABLE 4

Multiple logistic regression analyses of betel-quit use categories as a risk factor for the metabolic syndrome and its 5 components<sup>1</sup>

Component	Odds ratio (95% CI) <sup>2</sup>	P for trend <sup>3</sup>
Metabolic syndrome (yes or no)	1.06 (0.89, 1.3)	0.52
Abdominal obesity	1.03 (0.84, 1.26)	0.78
Hypertriglycerolemia	1.2 (0.9, 1.5)	0.18
Low HDL cholesterol	0.86 (0.66, 1.1)	0.26
High blood pressure <sup>4</sup>		
Men	1.1 (0.9, 1.4)	0.25
Women	2.0 (1.4, 3.0)	0.002
Hyperglycemia	0.99 (0.8, 1.2)	0.87

<sup>1</sup> n = 1986. The daily rate of betel-quit use was divided into 3 categories (none, low, or high). The effect of betel-quit use was adjusted for sex, age (y), smoking (pack-years), alcohol drinking (drink-years), dietary intakes, and physical activity. The data were reported separately for men and women for the dependent variables when there was a significant sex-by-tertile of betel-quit use interaction.

<sup>2</sup> The odds ratio was the ratio between the high and no betel-quit use categories.

<sup>3</sup> The linear trends in the differences between the different betel-quit use categories were tested by linear orthogonal polynomial contrasts in logistic regression.

<sup>4</sup> *P* < 0.05 for sex-by-tertile of betel-quit use interaction.

1208

TABLE 5

Linear regression and logistic regression analyses of the daily rate of betel-quit use as a risk factor for each of the 5 components of the metabolic syndrome<sup>1</sup>

	Coefficient	OR (95% CI)	P
Linear regression			
Waist circumference (cm)	1.4 ± 0.58 <sup>2</sup>	—	—
ln Triacylglycerol (mg/dL)	0.14 ± 0.03	—	0.03
ln HDL cholesterol (mg/dL)	-0.02 ± 0.03	—	0.001
SBP (mm Hg)	1.2 ± 0.4	—	0.53
DBP (mm Hg)	0.32 ± 0.9	—	0.01
ln Glucose (mg/dL)	-0.01 ± 0.01	—	0.72
Logistic regression			
Abdominal obesity	—	1.42 (1.2, 1.68)	0.001
Hypertriacylglycerolemia	—	1.33 (1.02, 1.73)	0.037
Low HDL cholesterol	—	1.13 (0.86, 1.5)	0.36
High blood pressure	—	1.2 (1.01, 1.4)	0.04
Hyperglycemia	—	0.98 (0.6, 1.6)	0.91

<sup>1</sup>  $n = 1986$ . The coefficients and odds ratios (ORs) are associated with a consumption rate of betel quid of 10 times/d, which is the 75th percentile of betel-quit use. The effect of betel-quit use was adjusted for sex, age (y), smoking (pack-years), alcohol drinking (drink-years), dietary intakes, and physical activity. SBP, systolic blood pressure; DBP, diastolic blood pressure.

<sup>2</sup>  $\bar{x} \pm \text{SEM}$  (all such values).

## DISCUSSION

The present study appears to be the first to show that, other than hyperglycemia and central obesity, the daily rate of betel-quit use is an independent risk factor for features of the metabolic syndrome. In view of the enormous world population (10%) that uses betel quid (2, 8) and the effect of the metabolic syndrome on global health (4), our finding has important epidemiologic implications.

The results were different when we analyzed betel-quit use as either a categorical or a continuous variable. The results of continuous variables are more reliable because the categorization of continuous variables leads to a loss of information (30). Thus, we found that the daily rate of betel-quit use was associated with 3 of the 5 components of the metabolic syndrome by multiple logistic regression: abdominal obesity, hypertriacylglycerolemia, and high BP (categorical variables). Similarly, it was associated with 3 of the 5 components of metabolic syndrome by multiple linear regression: waist circumference, serum triacylglycerol, and SBP (continuous variables).

Note that the effect of betel-quit use was independent of the other risk factors, which were examined by using multiple logistic regression analysis. However, due to the complex nature of independent risk factor research in epidemiology, we cannot dismiss the possibility of residual confounding by other as yet unknown factors (31) that may emerge in future studies.

The mechanism of betel-induced abdominal obesity and hypertriacylglycerolemia is not known. However, a study conducted in India found that arecoline suppressed appetite while increasing postprandial carbohydrate use in 15 men (32). Thus, betel-induced abdominal obesity is likely to depend on factors other than arecoline. On the other hand, betel-quit use may increase serum triacylglycerol secondary to the induction of central obesity.

The mechanism via which betel induces high BP is also not known. However, some studies found that betel-quit use acutely increased BP, probably by activating sympathetic nerves (3), which is a feature of essential hypertension (33). Interestingly,

betel quid-induced sympathetic activation is also mediated by factors other than arecoline, a parasympathomimetic agent (3).

Our finding that betel-quit use was not significantly associated with hyperglycemia contrasts those of 3 previous studies (8, 9, 34). The first study, which was conducted in New Guinea ( $n = 769$ ), showed that betel-quit use was associated with DM (9). However, that study defined DM as fasting capillary blood glucose  $\geq 7$  mmol/L, which is different from the World Health Organization definition of DM (fasting venous or capillary whole blood glucose  $\geq 6.1$  mmol/L) (25). Moreover, the dose-dependent effects of betel-quit use were not studied, in contrast to the present study. The second study, which was conducted in Taiwan ( $n = 14\ 816$ ), showed that betel-quit use was associated with hyperglycemia and DM in men (34). However, the 2 studies did not exclude specimens with hemolysis, and hemolysis affects the testing of blood glucose concentrations (35). Moreover, the researchers did not exclude persons who fasted  $< 8$  h, but the definition of hyperglycemia depends on an adequate fasting time. In fact, we found that betel-quit use was independently and positively associated with DM (OR: 2.4; 95% CI: 1.5, 4.0;  $P = 0.002$ ) if we increased the sample size to 2215 by including persons who fasted  $< 8$  h and blood specimens with hemolysis ( $n = 250$ ). Thus, the reduction of sample size would itself tend to reduce the chance of detecting a significant relation between betel-quit use and hyperglycemia. A third study conducted in Bangladeshis ( $n = 993$ ) showed that betel-quit use was associated with hyperglycemia only in women (8). The first and third studies had a smaller sample size, whereas the second study had a bigger sample size, than did our study. However, in contrast with our population-based study, the other 3 studies were community-based studies, which thereby lack generalizability to the population.

Interestingly, one study conducted in Taiwan showed that the prevalence of betel-quit use in patients with DM was 13.2% (36). In contrast, the prevalence of betel-quit use in patients with and without DM in our study was 14% and 16.2% ( $P = 0.56$ ), respectively.



One confounding factor is that the fasting glucose concentration alone is not sensitive enough for the detection of either impaired glucose tolerance or DM. For example, studies conducted in Canada and Taiwan showed that fasting glucose concentrations missed 16.6–23% of persons with impaired glucose tolerance or DM (37, 38). Additionally, betel quid (which contains arecoline) is often chewed with Piper betle leaves, which contain short-lived hypoglycemic agents (39) and hydroxychavicol (40). Note that both arecoline and hydroxychavicol have short-term hypoglycemic activities (40, 41).

We speculate that betel quid induces the metabolic syndrome, insulin resistance, or both by the several mechanisms. First, betel quid induces sympathetic activation (3), which is present in insulin resistance and the metabolic syndrome (33). Second, betel quid is associated with central obesity, itself a major risk factor for insulin resistance and the metabolic syndrome (42). Third, arecal alkaloids lead to  $\gamma$ -aminobutyric acid receptor blockade (43), and defective  $\gamma$ -aminobutyric acid neuromodulation was suggested to be a mechanism that induces insulin resistance (44). Fourth, betel quid induces oxidative stress (45) and inflammation (46), 2 conditions causally linked to insulin resistance (5, 47). Finally, specific arecal nitrosamines may be diabetogenic, as are various structurally similar nitroso compounds such as Streptozotocin, the structure of which leads to the targeting of islet  $\beta$  cell glucose receptors (8). However, betel quid-induced hyperglycemia may be masked by the effects of Piper betle leaves.

In conclusion, the daily rate of betel-quid use was independently and positively associated with the metabolic syndrome and 3 of its components (abdominal obesity, hypertriglycerolemia, and high BP) in a dose-dependent manner. Moreover, we found that, although men were more likely to be betel users than women and the prevalence of 4 of the 5 components of the metabolic syndrome were different between the sexes, the prevalence of the metabolic syndrome was not significantly different between the men and women. **E**

We thank Academia Sinica for data distribution and for their assistance.

J-YG was involved in the study design and analysis. L-YC was involved in the data collection and statistical analysis. H-CC was involved in the fund raising, study design, and collaborative analysis. None of the authors had any conflicts of interest.

## REFERENCES

1. IARC Working Group on the Evaluation of Carcinogenic Risks to Humans. Betel-quid and areca-nut chewing and some areca-nut derived nitrosamines. IARC Monogr Eval Carcinog Risks Hum 2004;85:1–334.
2. Nelson BS, Heischouer B. Betel nut: a common drug used by naturalized citizens from India, Far East Asia, and the South Pacific Islands. Ann Emerg Med 1999;34:238–43.
3. Chu NS. Neurological aspects of areca and betel chewing. Addict Biol 2002;7:111–4.
4. Anonymous. Executive Summary of the Third Report of the National Cholesterol Education Program (NCEP) Expert Panel on Detection, Evaluation, and Treatment of High Blood Cholesterol in Adults (Adult Treatment Panel III). JAMA 2001;285:2486–97.
5. Eckel RH, Grundy SM, Zimmet PZ. The metabolic syndrome. Lancet 2005;365:1415–28.
6. Tsai JF, Jeng JE, Chuang LY, et al. Habitual betel quid chewing as a risk factor for cirrhosis: a case-control study. Medicine (Baltimore) 2003;82:365–72.
7. Tsai JF, Jeng JE, Chuang LY, et al. Habitual betel quid chewing and risk for hepatocellular carcinoma complicating cirrhosis. Medicine (Baltimore) 2004;83:176–87.
8. Mannan N, Boucher BJ, Evans SJ. Increased waist size and weight in relation to consumption of *Areca catechu* (betel-nut): a risk factor for increased glycaemia in Asians in east London. Br J Nutr 2000;83:267–75.
9. Benjamin AL. Community screening for diabetes in the National Capital District, Papua New Guinea: is betelnut chewing a risk factor for diabetes? P N G Med J 2001;44:101–7.
10. Boucher BJ, Ewen SW, Stowers JM. Betel nut (*Areca catechu*) consumption and the induction of glucose intolerance in adult CD1 mice and in their F1 and F2 offspring. Diabetologia 1994;37:49–55.
11. Pan WH, Yeh WT, Chang HY, Hwu CM, Ho LT. Prevalence and awareness of diabetes and mean fasting glucose by age, sex, and region: results from the Nutrition and Health Survey in Taiwan, 1993–1996. Diabet Med 2003;20:182–5.
12. Pan WH, Kao MD, Tzeng MS, et al. Nutrition and health survey in Taiwan (NAHSIT) 1993–1996: design, contents, and operations. Nutr Sci J 1999;24:1–10.
13. Huang SL, Pan WH. Dietary fats and asthma in teenagers: analyses of the first Nutrition and Health Survey in Taiwan (NAHSIT). Clin Exp Allergy 2001;31:1875–80.
14. Pan WH, Chang YH, Chen JY, Wu SJ, Tzeng MS, Kao MD. Nutrition and Health Survey in Taiwan (NAHSIT) 1993–1996: Dietary nutrient intakes assessed by 24-hour recall. Nutr Sci J 1999;24:11–40.
15. Department of Health. Nutrient Composition Data Bank for Foods of Taiwan Area. Taipei, Taiwan: Department of Health, Republic of China, 1998.
16. Huang SL, Lin KC, Pan WH. Dietary factors associated with physician-diagnosed asthma and allergic rhinitis in teenagers: analyses of the first Nutrition and Health Survey in Taiwan. Clin Exp Allergy 2001;31:259–64.
17. Tzeng MS, Kao MD, Yeh WT. Food consumption frequency and eating habit among Taiwanese-NAHSIT 1993–96. Nutr Sci J 1999;24:59–80.
18. Chang HY, Suchindran CM, Pan WH. Using the overdispersed exponential family to estimate the distribution of usual daily intakes of people aged between 18 and 28 in Taiwan. Stat Med 2001;20:2337–50.
19. Lee MMS. Reliability and validity of a food frequency questionnaire used in Taiwan. Taipei, Taiwan: National Science Council, 1999.
20. Lin YC, Yen LL, Chen SY, et al. Prevalence of overweight and obesity and its associated factors: findings from National Nutrition and Health Survey in Taiwan, 1993–1996. Prev Med 2003;37:233–41.
21. Pan WH, Yeh WT, Hwu CM, Ho LT. Undiagnosed diabetes mellitus in Taiwanese subjects with impaired fasting glycemia: impact of female sex, central obesity, and short stature. Chin J Physiol 2001;44:44–51.
22. Pan WH, Flegal KM, Chang HY, Yeh WT, Yeh CJ, Lee WC. Body mass index and obesity-related metabolic disorders in Taiwanese and US whites and blacks: implications for definitions of overweight and obesity for Asians. Am J Clin Nutr 2004;79:31–9.
23. Tan CE, Ma S, Wai D, Chew SK, Tai ES. Can we apply the National Cholesterol Education Program Adult Treatment Panel definition of the metabolic syndrome to Asians? Diabetes Care 2004;27:1182–6.
24. Alberti KG, Zimmet P, Shaw J. The metabolic syndrome—a new worldwide definition. Lancet 2005;366:1059–62.
25. Alberti KG, Zimmet PZ. Definition, diagnosis and classification of diabetes mellitus and its complications. Part 1: diagnosis and classification of diabetes mellitus provisional report of a WHO consultation. Diabet Med 1998;15:539–53.
26. Chang HY, Yeh WT, Chang YH, Tsai KS, Pan WH. Prevalence of dyslipidemia and mean blood lipid values in Taiwan: results from the Nutrition and Health Survey in Taiwan (NAHSIT, 1993–1996). Chin J Physiol 2002;45:187–97.
27. Lowry SR. Use and misuse of multiple comparisons in animal experiments. J Anim Sci 1992;70:1971–7.
28. Lomax LG. Multiple-comparison procedures. 2nd ed. In: Lomax LG, ed. Statistical concepts—a second course for education and the behavioral sciences. Mahwah, NJ: Lawrence Erlbaum Associates, 2000:108–37.
29. Katz MH. Multivariable analysis: a primer for readers of medical research. Ann Intern Med 2003;138:644–50.
30. Royston P, Altman DG, Sauerbrei W. Dichotomizing continuous predictors in multiple regression: a bad idea. Stat Med 2006;25:127–41.
31. Brotman DJ, Walker E, Lauer MS, O'Brien RG. In search of fewer independent risk factors. Arch Intern Med 2005;165:138–45.
32. Strickland SS, Veena GV, Houghton PJ, Stanford SC, Kurpad AV. Areca nut, energy metabolism and hunger in Asian men. Ann Hum Biol 2003;30:26–52.
33. Huggert RJ, Burns J, Mackintosh AF, Mary DA. Sympathetic neural



- activation in nondiabetic metabolic syndrome and its further augmentation by hypertension. *Hypertension* 2004;44:847-52.
34. Tung TH, Chiu YH, Chen LS, Wu HM, Boucher BJ, Chen TH. A population-based study of the association between areca nut chewing and type 2 diabetes mellitus in men (Keelung Community-based Integrated Screening programme No. 2). *Diabetologia* 2004;47:1776-81.
  35. Brady J, O'Leary N. Interference due to haemolysis in routine photometric analysis—a survey. *Ann Clin Biochem* 1998;35:128-34.
  36. Chang HY, Chiou CJ, Lin MC, Lin SH, Tai TY. A population study of the self-care behaviors and their associated factors of diabetes in Taiwan: results from the 2001 National Health Interview Survey in Taiwan. *Prev Med* 2005;40:344-8.
  37. Anand SS, Razak F, Vuksan V, et al. Diagnostic strategies to detect glucose intolerance in a multiethnic population. *Diabetes Care* 2003;26:290-6.
  38. Li CL, Tsai ST, Chou P. Comparison of metabolic risk profiles between subjects with fasting and 2-hour plasma glucose impairment: the Kinmen Study. *J Clin Epidemiol* 2002;55:19-24.
  39. Arambewela LS, Arawawala LD, Ratnasooriya WD. Antidiabetic activities of aqueous and ethanolic extracts of Piper betle leaves in rats. *J Ethnopharmacol* 2005;102:239-45.
  40. Boucher B. Diabetes in British South Asians: nature, nurture, and culture. *Diabet Med* 1997;14:707-8.
  41. Chempakam B. Hypoglycaemic activity of arecoline in betel nut *Areca catechu* L. *Indian J Exp Biol* 1993;31:474-5.
  42. Carr DB, Utschneider KM, Hull RL, et al. Intra-abdominal fat is a major determinant of the National Cholesterol Education Program Adult Treatment Panel III criteria for the metabolic syndrome. *Diabetes* 2004;53:2087-94.
  43. Boucher BJ, Mannan N. Metabolic effects of the consumption of *Areca catechu*. *Addict Biol* 2002;7:103-10.
  44. Blasi C, Jeanrenaud B. Insulin resistance syndrome: defective GABA neuromodulation as a possible hereditary pathogenetic factor (the 'GABA hypothesis'). *Med Hypotheses* 1993;40:197-206.
  45. Jeng JH, Chang MC, Hahn LJ. Role of areca nut in betel quid-associated chemical carcinogenesis: current awareness and future perspectives. *Oral Oncol* 2001;37:477-92.
  46. Jeng JH, Wang YJ, Chiang BL, et al. Roles of keratinocyte inflammation in oral cancer: regulating the prostaglandin E2, interleukin-6 and TNF- $\alpha$  production of oral epithelial cells by areca nut extract and arecoline. *Carcinogenesis* 2003;24:301-15.
  47. Ceriello A, Motz E. Is oxidative stress the pathogenic mechanism underlying insulin resistance, diabetes, and cardiovascular disease? The common soil hypothesis revisited. *Arterioscler Thromb Vasc Biol* 2004;24:816-23.



# A population-based study of the association between betel-quid chewing and the metabolic syndrome in men<sup>1-3</sup>

Amy Ming-Fang Yen, Yueh-Hsia Chiu, Li-Sheng Chen, Hui-Min Wu, Chih-Chung Huang, Barbara J Boucher, and Tony Hsiu-Hsi Chen

## ABSTRACT

**Background:** Betel-quid chewing, an established risk factor for oropharyngeal malignancy, is associated with hyperglycemia and obesity. Associations with other characteristics of the metabolic syndrome have not been reported.

**Objective:** This study examined associations between betel-quid chewing and the metabolic syndrome, allowing for recognized risk factors and exploring dose-response effects in a population-based study.

**Design:** Age-specific prevalence rates of the metabolic syndrome were examined in betel-quid chewing and nonchewing men ( $n = 19\,839$ ) recruited into the Keelung Community-based Integrated Screening program in 2001–2003. The independent effect of betel-quid chewing on metabolic syndrome risk was examined by using multiple logistic regression with control for well-recognized risk factors (eg, education, physical activity, and dietary factors) and dose-response effects were examined by using trend tests.

**Results:** The age-adjusted prevalence of the metabolic syndrome was highest in current chewers (25.13%), next highest in ex-chewers (22.04%), and lowest in nonchewers (15.73%) ( $P < 0.0001$ ). Odds ratios (95% CIs) for the metabolic syndrome were 1.38 (1.19, 1.60) and 1.78 (1.53, 2.08) in ex-chewers and current chewers, respectively, adjusted for other significant correlates such as a family history of hypertension and diabetes mellitus. Meaningful odds ratios for the metabolic syndrome components ranged from 1.24 for hyperglycemia (95% CI: 1.09, 1.64) to 1.90 (95% CI: 1.66, 2.19) for hypertriglycerolemia. Increasing odds ratios for the metabolic syndrome with higher consumption of betel quid (whether by rate of use, duration of use, or cumulative exposure) suggest dose-response effects.

**Conclusions:** After adjustment for well-established risk factors, our study showed independent predictive dose-response effects of betel-quid chewing for the metabolic syndrome and its components in a population-based study of men with a 15% prevalence of betel-nut chewing. *Am J Clin Nutr* 2006;83:1153–60.

**KEY WORDS** Metabolic syndrome, betel quid, *Areca catechu*, chewing, dose-response effect, community-based integrated screening, risk factors

## INTRODUCTION

Although chewing betel quid, containing *Areca catechu* palm nuts, is a recognized risk factor for oral premalignancy and cancer, few studies have focused on associations between betel-quid

chewing and chronic diseases, even though it is the fourth most common addictive habit worldwide (1). Betel-quid chewing has been shown to be associated with the development of obesity and hyperglycemia in mice (2) and with hyperglycemia and type 2 diabetes, epidemiologically, in humans (3, 4).

Furthermore, betel-quid chewing has been reported to be associated with increased waist size and weight, recognized features of the metabolic syndrome, in British South Asians (5). A review of the literature shows many reported physiologic and metabolic effects of betel-quid consumption (4). *Areca* alkaloids, the major psychoactive components of *Areca catechu* nuts, chewed alone in *Piper betle* (betel) leaf-wrapped quids or, as in Taiwan, with sliced inflorescence of *Piper betle* (*Lao-Hwa*) (1), are competitive inhibitors of  $\gamma$ -aminobutyrate receptors with widespread effects because  $\gamma$ -aminobutyrate receptors are found in the brain, cardiovascular system, lungs, gut, and pancreatic islets. *Areca catechu* nut (commonly called "betel nut") alkaloids activate the sympathetic nervous system (even at low doses), increase adrenal medullary catecholamine secretion, and at high doses can increase blood pressure. These are properties that could be expected to increase the risk of ischemic heart disease, although only one report suggests an association of acute coronary events with betel-quid chewing (6).

Betel-quid chewers are reported to be at increased risk of developing type 2 diabetes. Thus, it is important to establish whether there may also be associations between the betel habit (the chewing of *Areca catechu* nuts), used by 600 million people worldwide (1, 7), and the development of the metabolic syndrome because, with or without overt diabetes, it is strongly associated with the development of atherosclerotic disease. The

<sup>1</sup> From the Institute of Preventive Medicine, College of Public Health, National Taiwan University, Taipei, Taiwan (AM-FY, L-SC, C-CH, and TH-HC); the Taiwan Association of Medical Screening, Taipei, Taiwan (AM-FY, L-SC, H-MW, C-CH, and TH-HC); the Health Bureau of Keelung City, Keelung City, Taiwan (Y-HC); the Graduate Institute of Epidemiology, College of Public Health, National Taiwan University, Taipei, Taiwan (H-MW); the Center for Diabetes & Metabolic Medicine, Queen Mary School of Medicine & Dentistry, Royal London Hospital, London, United Kingdom (BJB).

<sup>2</sup> Supported by the National Science Council (NSC 91-2320-B002-171; NSC 91-2320-B002-172).

<sup>3</sup> Address reprint requests to TH-H Chen, Institute of Preventive Medicine, College of Public Health, Room 521, No. 17, Hsu-Chow Road, National Taiwan University, Taipei, Taiwan. E-mail: chenlin@ntu.edu.tw.

Received October 5, 2005.

Accepted for publication January 13, 2006.

aims of the present study, therefore, were 1) to assess whether betel-quid chewers have higher prevalence rates of the metabolic syndrome than do nonchewers, after control for other recognized risk factors for the metabolic syndrome, in a population-based study, and 2) to determine whether there was evidence of dose-response effects for the risk of the metabolic syndrome, or any of its component features, associated with the duration of betel-quid chewing, the rate of use, cumulative exposure, and the duration of time after quitting betel-quid chewing (quitting-years).

## SUBJECTS AND METHODS

### Subjects

Subjects were participants in the Keelung Community-based Integrated Screening (KCIS) program, a screening program targeting 5 neoplastic diseases (cervical, colorectal, liver, oropharyngeal, and breast cancers) and 3 nonneoplastic chronic diseases (diabetes mellitus, hypertension, and hyperlipidemia) that began recruitment in 1999 in Keelung, Taiwan. Details of the study design, implementation, and preliminary results have been described in full elsewhere (8). In brief, the invited population of the KCIS program was derived from 217 884 people aged 30–79 y resident in Keelung in 1999. Because the Pap smear screening program was a major screening target at that time, we initially invited women who had no history of having Pap smear or who had not undergone a Pap smear for  $\geq 3$  y and used this invitation as an incentive to invite their husbands and other relatives to attend a series of screenings integrated within the KCIS program. The overall attendance rate for women invited to attend the Pap smear screening was 80%. The total number of participants had reached 61 653 by the end of 2003 (28.3% of the total population). A comparison of attendant with nonattendant subjects with respect to age, sex, and education showed that the old and the less-educated women were more likely to attend the KCIS than were the men, the young, or the highly educated and it became necessary to control for age and education in multivariate analysis (see below) for the men only.

Because the measurement of HDL cholesterol only began in 2001, only those subjects screened between 1 January 2001 and 31 December 2003 were included in the present subgroup analyses, which allowed the use of consistent criteria for the presence of the metabolic syndrome as defined by using modified National Cholesterol Education Panel Adult Treatment Panel III (NCEP ATP III) criteria (see below) (9). A total of 53 948 subjects (20 111 men and 33 837 women) participated in the KCIS program between 2001 and 2003 after having given informed consent. After the exclusion of 569 subjects without adequate records for betel chewing, the prevalence of betel nut chewers (including both ex- and current chewers) was 15.1% in men and 0.8% in women. In view of the low prevalence of betel chewing in women, data analysis was limited to 19 839 men.

### Data collection

Questionnaire data on demographic features, dietary habits (intakes of meat, vegetables, fruit, beans, fish, seafood, milk, and coffee), lifestyle (betel-quid chewing, smoking, drinking, and physical activity), personal and family disease history (diabetes mellitus, hypertension, cardiovascular and cerebrovascular disease, hyperlipidemia, and stroke), and data relating to cancer

risks, was obtained by one-to-one interviews conducted by specially trained public health nurses or volunteer workers. Physical activity was defined as nonoccupational exercise, and information was collected on the number of sessions per week and categorized as none, 1–3 times/wk, or  $\geq 4$  times/wk in the following analysis. Data on the diet during the previous 6 mo (including seafood, meat, fish, fried oil, bean or egg products, fruit and vegetables, milk, soda, and coffee) was also obtained. Food modes and standard dishes or containers of each food were displayed to assist in estimates of portion sizes for food consumed per meal. The frequency of consumption was then categorized into 5 groups: never or seldom, 1–2 times/wk, 3–4 times/wk, 5–6 times/wk, and  $\geq 7$  times/wk. Note that the intake of meat and vegetables was recorded in days. Physical measurements, including reclining blood pressure after 5 min of rest, were then recorded. Fasting blood samples were drawn at recruitment and repeated yearly, ie, both during the 3-y study period and during follow-up. Anthropometric measurements were made by trained staff; height was measured with a stadiometer, waist and hip circumferences (to 0.1 cm) were measured with a standard tape measure, and weight (to 0.1 kg) was measured with standardized weight scales. Waist size was measured midway between the inferior margin of the rib cage and the iliac crest horizontally, and hip circumference was measured as the maximum horizontal circumference around the buttocks. The serum biomarkers measured included fasting glucose, aspartate transaminase, alanine transaminase, triacylglycerol, total cholesterol, and LDL- and HDL-cholesterol concentrations.

The definition of the metabolic syndrome used was based on NCEP ATP III criteria (9), adjusted for waist size in Asian subjects (10). Metabolic syndrome was defined as present when subjects met  $\geq 3$  of the following criteria: 1) central obesity (waist circumference  $\geq 90$  cm for men and  $\geq 80$  cm for women), 2) hypertriacylglycerolemia ( $\geq 150$  mg/dL), 3) an abnormally low HDL-cholesterol concentration ( $< 40$  mg/dL for men and  $< 50$  mg/dL for women), 4) elevated blood pressure ( $\geq 130$  mm Hg systolic or  $\geq 85$  mm Hg diastolic), or 5) an elevated fasting glucose concentration ( $\geq 110$  mg/dL).

### Statistical analysis

Comparisons of demographic features, lifestyle and dietary factors, and family history across current-, ex-, and non-betel quid chewers were made by using chi-square and analysis of variance tests for categorical and continuous variables, respectively. Multiple logistic regression analysis was used to obtain adjusted odds ratios (ORs) and their 95% CIs for the presence of the metabolic syndrome in relation to betel quid use (classified as current chewer, ex-chewer, or nonchewer). Analysis for trend was used to investigate dose-response effects of the duration of betel-quid chewing, of rate of use, of cumulative exposure (quid-days), and of quitting years. To determine whether the risk of the metabolic syndrome decreased with time after quitting in ex-chewers by cumulative exposure to previous betel chewing, after control for risk factors that were significantly correlated with the metabolic syndrome, cumulative exposure was categorized into 4 groups:  $< 10\,000$ ,  $10\,000$ – $32\,000$ ,  $> 32\,000$ – $79\,000$ , and  $\geq 79\,000$  quid-days. All statistical analyses were carried out by using SAS software (version 8.0; SAS Institute Inc, Cary, NC).



TABLE 1

Distribution of demographic and biochemical variables by betel-quid chewing status in men: Keelung Community-based Integrated Screening Program, 2001-2003

	Nonchewer (n = 16 847)	Ex-chewer (n = 1569)	Current chewer (n = 1423)	P
<b>Demographic variables</b>				
Age (y) <sup>1</sup>	53.1 ± 15.3 <sup>2</sup>	44.0 ± 10.6	42.7 ± 10.9	< 0.0001
Education (%) <sup>2</sup>				< 0.0001
College or above	25.2	11.3	9.2	
Senior high school	27.9	45.2	42.5	
Junior high school or below	46.9	43.4	48.3	
Occupation (%) <sup>2</sup>				< 0.0001
None or retired	47.2	34.2	31.8	
Manual	15.9	24.4	31.7	
Teacher, officer holder, military	11.0	9.1	6.4	
Business, professional	10.1	10.3	7.6	
Service trade, other	15.8	22.0	22.6	
<b>Lifestyle factors</b>				
Physical activity (%) <sup>1</sup>				< 0.0001
No regular habits	29.8	37.6	53.3	
1-3 times/wk	37.8	45.9	34.9	
≥4 times/wk	32.5	16.5	11.8	
Smoking habit (%) <sup>2</sup>				< 0.0001
Nonsmoker	49.2	5.2	9.6	
Ex-smoker	13.7	22.5	6.5	
Current smoker	37.1	72.3	83.9	
Alcohol habit (%) <sup>1</sup>				< 0.0001
Nonuser	60.0	18.5	19.7	
Ex-user	7.4	22.2	7.2	
Current user	32.6	59.3	73.1	
<b>Dietary intake (%)</b>				
Meat <sup>4</sup>				< 0.0001
Never or seldom	26.9	16.6	15.4	
3-6 times/wk	42.1	44.7	43.1	
1-2 times/d	23.2	27.1	29.1	
≥3 times/d	7.8	11.6	12.3	
Fish <sup>4</sup>				0.5392
Never or seldom	17.7	14.9	17.0	
1-2 times/wk	6.5	7.8	5.9	
3-4 times/wk	32.1	31.5	33.7	
5-6 times/wk	15.4	20.0	20.0	
≥7 times/wk	28.4	25.8	24.3	
Vegetable <sup>4</sup>				< 0.0001
Never or seldom	1.7	1.7	3.1	
1/2 bowls/d	21.1	27.6	30.5	
1 bowl/d	27.8	28.8	26.9	
2 bowls/d	25.5	22.8	20.0	
≥3 bowls/d	24.0	19.0	19.4	
Fruit <sup>4</sup>				0.1847
Never or seldom	25.1	23.8	24.7	
1-2 times/wk	9.7	10.3	7.3	
3-4 times/wk	26.0	28.1	25.8	
5-6 times/wk	9.3	16.2	18.2	
≥7 times/wk	29.9	21.6	24.1	
Bean <sup>4</sup>				0.0002
Never or seldom	26.0	19.5	22.3	
1-2 times/wk	6.9	8.1	6.9	
3-4 times/wk	33.5	35.8	34.1	
5-6 times/wk	16.2	19.9	20.2	
≥7 times/wk	17.7	16.8	16.5	
Milk <sup>4</sup>				0.3983
Never or seldom	34.6	32.5	35.7	
1-2 times/wk	5.3	4.9	3.4	
3-4 times/wk	17.3	17.1	15.0	
5-6 times/wk	12.3	16.1	15.5	
≥7 times/wk	30.6	29.4	30.4	

(Continued)

1214



TABLE 1 (Continued)

	Nonchewer (n = 16 847)	Ex-chewer (n = 1569)	Current chewer (n = 1423)	P
Coffee <sup>a</sup>				0.0010
Never or seldom	48.7	45.5	41.5	
1-2 times/wk	5.6	8.2	6.9	
3-4 times/wk	11.7	17.1	14.9	
5-6 times/wk	7.7	8.7	10.7	
≥7 times/wk	26.3	20.5	26.0	
Family history in second-degree relatives (%)				
Diabetes <sup>b</sup>	12.8	17.0	16.2	< 0.0001
Hypertension <sup>b</sup>	16.6	19.9	17.4	0.0031
Cerebrovascular disease <sup>c</sup>	7.0	9.9	7.7	0.0001
Cardiovascular disease <sup>d</sup>	5.9	6.6	5.8	0.4767

<sup>a</sup> ANOVA.<sup>b</sup>  $\bar{x} \pm$  SD (all such values).<sup>c</sup> Chi-square test.<sup>d</sup> Mean score test for ordinal-scaled response measures.

## RESULTS

The distribution of demographic, lifestyle, and dietary factors among betel-quit chewers and nonchewers is shown in Table 1. Chewers were younger, less educated, and more likely to report manual labor or service jobs as their occupation than were the nonchewers. As far as the lifestyle factors were concerned, less physical activity and an increased prevalence of smoking and drinking alcohol were found in betel nut chewers ( $P < 0.001$ ). Chewers also ate more meat, beans, and coffee and less vegetables than did nonchewers. There were no significant differences in any other lifestyle variable between chewers and nonchewers. Chewers had more second-degree relatives with diabetes and hypertension, but the rates of cardiovascular disease in second-degree relatives did not differ significantly between chewers and nonchewers.

Crude prevalence rates of the metabolic syndrome varied with betel-quit chewing status, being highest in current chewers and lowest in nonchewers ( $P < 0.0001$ ; Table 2). When stratified into 10-y age groups, prevalence rates were significantly higher in current chewers or ex-chewers at all ages, except in the few

subjects aged 70-79 y. There was no significant interaction between age and betel-quit chewing habits on the risk of the metabolic syndrome ( $P = 0.09$ ). The age-standardized prevalence rate of metabolic syndrome remained higher in current chewers and increased, though less so, in ex-chewers as compared with nonchewers ( $P < 0.0001$ ).

The results of multiple logistic regression analysis, in which betel-quit chewing habits were included together with other risk factors and confounding factors, are shown in Table 3. Higher risks for the metabolic syndrome were found with age, lower education, working in service trades, regularly eating meat, regularly drinking milk and coffee, and a family history of diabetes or hypertension. Subjects taking regular physical activity, working in manual or service jobs, and with a regular intake of vegetables or beans had a lower than average risk of the metabolic syndrome. After adjustment for these confounding factors, the adjusted OR for the association between betel-quit usage and the metabolic syndrome in men was 1.38 (95% CI: 1.19, 1.61) and 1.78 (1.53, 2.08) for ex-chewers and current chewers, respectively.

TABLE 2

The prevalence of the metabolic syndrome stratified by age in men by betel-quit chewing status and after adjustment for age: Keelung Community-based Integrated Screening Program, 2001-2003<sup>1</sup>

Age group	Nonchewer			Ex-chewer			Current chewer		
	Total n	No. with metabolic syndrome	Prevalence %	Total n	No. with metabolic syndrome	Prevalence %	Total n	No. with metabolic syndrome	Prevalence %
30-39 y	3647	369	10.12	575	98	17.04	594	108	18.18
40-49 y	3588	605	16.86	575	117	20.35	486	125	25.72
50-59 y	3006	664	22.09	274	93	33.94	219	70	31.96
60-69 y	3450	830	24.06	117	35	29.91	106	42	39.62
70-79 y	3156	789	25.00	28	6	21.43	18	6	33.33
Total	16 847	3257	19.33	1569	349	22.24	1423	351	24.67
Age-adjusted prevalence <sup>2</sup>			15.73			22.04			25.13

<sup>1</sup> Age and betel-quit chewing status were significantly associated with the metabolic syndrome ( $P < 0.0001$  for both). There was no interaction between age and betel-quit chewing status for the risk of the metabolic syndrome ( $P = 0.09$ ).

<sup>2</sup> Based on the standard world population (11).



TABLE 3

Adjusted odds ratios (aOR) for significant risk factors for the metabolic syndrome in 19 839 men identified by using multiple logistic regression models: Keelung Community-based Integrated Screening Program, 2001–2003<sup>1</sup>

	aOR	95% CI	P <sup>2</sup>
Model 1: adjusted for age			
Betel-quad chewing status			
Nonchewer	1.00	—	< 0.0001
Ex-chewer	1.52	1.33, 1.73	
Current chewer	1.80	1.58, 2.06	
Model 2: adjusted for age and other confounders <sup>3</sup>			
Betel-quad chewing status			
Nonchewer	1.00	—	< 0.0001
Ex-chewer	1.38	1.19, 1.61	
Current chewer	1.78	1.53, 2.08	
Age			
<40 y	1.00	—	< 0.0001
40–49 y	1.66	1.46, 1.88	
50–59 y	2.50	2.18, 2.87	
60–69 y	3.04	2.61, 3.54	
≥70 y	3.38	2.87, 3.97	
Education			
College or above	1.00	—	0.03
Senior high school	1.15	1.02, 1.29	
Junior high school or below	1.18	1.04, 1.33	
Lifestyle factors			
Physical activity			
No regular habits	1.00	—	0.003
1–3 times/wk	0.89	0.80, 0.98	
≥4 times/wk	0.85	0.77, 0.93	
Occupation			
None or retired	1.00	—	< 0.0001
Manual	0.79	0.70, 0.89	
Teacher, officer holder, military	1.00	0.86, 1.16	
Business, professional	0.84	0.72, 0.98	
Service trade, others	1.18	1.06, 1.33	
Smoking habit			
Nonsmoker	1.00	—	0.64
Ex-smoker	0.95	0.84, 1.08	
Current smoker	1.00	0.92, 1.10	
Alcohol habit			
Nonuser	1.00	—	0.01
Ex-user	1.23	1.07, 1.42	
Current user	1.02	0.93, 1.11	
Dietary intake <sup>4</sup>			
Meat	1.13	1.08, 1.18	< 0.0001
Vegetable	0.91	0.87, 0.94	< 0.0001
Fruit	0.94	0.92, 0.97	< 0.0001
Bean	0.98	0.96, 1.01	0.2392
Fish	1.00	0.97, 1.03	0.8593
Milk	1.04	1.02, 1.07	0.0004
Coffee	1.02	1.00, 1.05	0.0555
Family history in second-degree relatives			
Diabetes (yes vs no)	1.44	1.28, 1.61	< 0.0001
Hypertension (yes vs no)	1.23	1.11, 1.37	< 0.0001
Cerebrovascular disease (yes vs no)	1.08	0.94, 1.25	0.3025
Cardiovascular disease (yes vs no)	1.05	0.89, 1.24	0.5367

<sup>1</sup> 2992 men were identified as betel-quad chewers, and 16 847 men were identified as nonchewers.

<sup>2</sup> The overall effects for betel-quad chewing habit, age, education, physical activity, occupation, smoking habit, alcohol habit, dietary factors, and family history were tested by the likelihood ratio test.

<sup>3</sup> The other confounders were all risk factors significantly related to the risk of the metabolic syndrome.

<sup>4</sup> Dietary factors were analyzed after categorization into 4 groups for meat intake and into 5 groups for fish, vegetable, fruit, bean, milk, and coffee intakes as shown in Table 1.

TABLE 4

Multiple logistic regression modeling on the risk factors associated with the metabolic syndrome in 19 839 men: Keelung Community-based Integrated Screening Program, 2001–2003<sup>1</sup>

Variables	Age-adjusted prevalence <sup>2</sup>	aOR <sup>3</sup>	95% CI
Duration of betel-quid chewing			
None	15.73	1.00	
<10 y	18.01	1.09	0.84, 1.41
10–19 y	26.48	1.82	1.51, 2.20
≥20 y	27.50	1.66	1.38, 1.98
<i>P</i> for trend		< 0.0001	
Frequency of betel-quid chewing			
None	15.73	1.00	
<10 pieces/d	20.71	1.37	1.16, 1.61
10–19 pieces/d	22.60	1.48	1.20, 1.84
≥20 pieces/d	34.00	2.75	2.17, 3.48
<i>P</i> for trend		< 0.0001	
Cumulative exposure			
None	15.73	1.00	
<1.0 × 10 <sup>4</sup> quid-days	17.30	1.11	0.85, 1.46
1.0–3.2 × 10 <sup>4</sup> quid-days	23.38	1.45	1.15, 1.84
>3.2–7.9 × 10 <sup>4</sup> quid-days	22.13	1.53	1.21, 1.93
≥7.9 × 10 <sup>4</sup> quid-days	32.93	2.24	1.81, 2.76
<i>P</i> for trend		< 0.0001	
Quitting-years <sup>4</sup>			
None but never chewed	15.73	1.00	
Current chewing	25.13	1.78	1.53, 2.08
<5 y	22.78	1.51	1.20, 1.89
5–10 y	22.34	1.27	0.92, 1.77
>10 y	14.79	0.98	0.63, 1.52
<i>P</i> for trend		< 0.0001	

<sup>1</sup> The confounders adjusted for in the models included age, education level, physical activity, occupation, smoking habit, alcohol habit, dietary factors, and family history of diabetes, hypertension, and cerebrovascular and cardiovascular disease in second-degree relatives. *P* values for tests for interaction between betel-quid chewing status (ex-chewers and current chewers) and duration of use, between chewing status and rate of use, and between chewing status and cumulative exposure were 0.85, 0.42, and 0.44, respectively.

<sup>2</sup> Based on the standard world population (11).

<sup>3</sup> Adjusted odds ratio.

<sup>4</sup> Defined as the length of time after quitting betel-quid chewing.

Age-adjusted prevalence rates by duration of chewing, rate of use, cumulative exposure, and quitting years and trend tests for the corresponding dose response are presented in Table 4. Significant dose-response effects for the association of betel-quid chewers, including ex-chewers and current chewers, with the metabolic syndrome for duration, rate of use, cumulative exposure to the habit (duration × daily betel-quid use), and quitting years of ex-chewers (*P* for trend < 0.0001 for all 4 effects) were observed. Chewers with >20 y exposure to the habit, for example, were 1.7 times (95% CI: 1.38, 1.98) as likely to have the metabolic syndrome than were nonchewers, whereas those with usage rates of >20 chews (pieces)/d or with the largest cumulative exposure to the habit (quid-days) had risks that were 2.7- and 2.2-fold those of nonchewers, respectively. Regarding the effect of cessation of chewing, the risks among exchewers decreased over time.

The magnitudes (ORs) of the associations of betel quid usage with the prevalence of individual components of the metabolic syndrome after adjustment for demographic variables, lifestyle factors, dietary factors, and family history among second-degree relatives in current chewers and in ex-chewers is shown in Table 5. The relations between chewing status and each of the abnormalities were statistically significant for waist (*P* = 0.0003), triacylglycerol (*P* < 0.0001), and hyperglycemia (*P* = 0.0203).

The OR for the association of betel chewing with hypertriglycerolemia was higher than that for the other significant associations shown in both current chewers and ex-chewers.

## DISCUSSION

On the basis of a large population-based study subgroup of men, age-standardized prevalence rates of the metabolic syndrome are highest in current betel-quid chewers, next highest in ex-chewers, and lowest in nonchewers. These increases in risk persisted after adjustment for other established metabolic syndrome risk factors. Furthermore, the risks of the metabolic syndrome increased in relation to quid-days, the duration of betel-quid chewing, and the cumulative exposure to betel. These findings, particularly the dose-response effects, support the suggestion that betel chewing is associated with an increased risk of the metabolic syndrome. The decrease in prevalence rates of the metabolic syndrome with increasing duration of cessation of the habit also supports this association, except for the lower prevalence rate in those aged >70 y. However, this finding could reflect increased deaths in *Areca* nut chewers, eg, from cancer or from the metabolic syndrome-associated vascular disease. Alternatively, this finding might be artifactual because of the small number of subjects in this group.

TABLE 5

Adjusted odds ratios (aOR) for betel-quid chewing status associated with abnormalities in components of the metabolic syndrome in 19 839 men: Keelung Community-based Integrated Screening program, 2001–2003

	Age-adjusted prevalence (%) <sup>1</sup>			Ex-chewer vs nonchewer		Current chewer vs nonchewer		P <sup>2</sup>
	Nonchewer	Ex-chewer	Current chewer	aOR	95% CI	aOR	95% CI	
Model 1: adjusted for age								
Waist	24.50	29.16	32.35	1.28	1.14, 1.44	1.53	1.35, 1.72	< 0.0001
Triacylglycerol	29.65	42.18	49.02	1.68	1.51, 1.87	2.21	1.97, 2.47	< 0.0001
HDL cholesterol	12.23	15.13	14.26	1.37	1.19, 1.59	1.21	1.04, 1.42	< 0.0001
Hypertension	51.58	54.15	51.81	1.13	1.02, 1.26	1.02	0.91, 1.14	0.0762
Hyperglycemia	9.45	10.80	11.91	1.22	1.02, 1.45	1.46	1.22, 1.74	< 0.0001
Model 2: adjusted for age and other confounders <sup>3</sup>								
Waist				1.05	0.91, 1.21	1.35	1.17, 1.56	0.0003
Triacylglycerol				1.40	1.23, 1.61	1.90	1.66, 2.19	< 0.0001
HDL cholesterol				1.21	1.01, 1.46	0.95	0.78, 1.15	0.0728
Hypertension				1.08	0.95, 1.23	0.88	0.77, 1.01	0.0603
Hyperglycemia				1.07	0.87, 1.31	1.24	1.09, 1.64	0.0203

<sup>1</sup> Based on the standard world population (11).

<sup>2</sup> The overall effect of betel-quid chewing status (nonchewer, ex-chewer, and current chewer) and the individual components of the metabolic syndrome was tested by using the likelihood ratio test.

<sup>3</sup> The other confounders were education level, physical activity, occupation, smoking habit, alcohol habit, dietary factors, and family history of diabetes, hypertension, and cerebrovascular and cardiovascular disease in second-degree relatives. This model also adjusted for each of the 5 components of the metabolic syndrome.

No comparably large population-based study appears to have been conducted that addressed the relation of betel-quid chewing to each of the components currently defining the metabolic syndrome in humans, although relations with increased glycemia, waist circumference, and weight have been reported (3–5). Our findings may have been confounded by the use of simple grading to assess lifestyle factors or by the lack of data on risk factors such as vitamin D deficiency (12). However, our findings are supported by earlier work in the CD1 mouse (2), in which a significant proportion of young adult animals fed high doses of betel quid for 5 d later developed central obesity (a doubling of body weight), permanent hyperglycemia, and histologic changes in pancreatic islets indistinguishable from those of human type 2 diabetes. Several mechanisms could account for these findings. These mechanisms included increased sympathetic activity due to *Arecal* alkaloids or damage to DNA by carcinogenic nitroso adducts of *Arecal* alkaloids (1), because many similarly conformed nitrosamines are diabetogenic in animals (13–15) and some, such as streptozotocin, are diabetogenic in humans (16). Other unidentified substances, including non-arecal nitroso compounds in *Lao-Hwa* betel-quid chews or in the Taiwanese diet, could also be contributory.

In view of the findings in mice, it was surprising that the association between betel-quid chewing and hyperglycemia ( $\geq 110$  mg/dL) was smaller than for the metabolic syndrome components such as hypertriacylglycerolemia. This may have been due to the criterion for diagnosis of the metabolic syndrome being based on fasting glucose concentrations, because both impaired glucose tolerance (IGT) and type 2 diabetes (determined by oral-glucose-tolerance test) can occur with fasting normoglycemia—overlap between impaired fasting glucose (IFG; 100–126 mg/dL) and IGT (normal fasting glucose but elevated 2-h glucose) being found in only 21% of Taiwanese subjects (17). If the diagnosis of glucose intolerance had been based on IFG,

$\approx 66.6\%$  of the subjects found to have IGT with abnormal cardiovascular disease profiles would have gone undetected. Subjects with IFG have abnormal  $\beta$  cell function (18), which suggests that the effects of betel chewing on insulin release, or secretion, may differ from the effects on insulin resistance. Additional reports of marked contrasts between the findings on fasting blood sugar and on the basis of hemoglobin A<sub>1c</sub> and 2-h oral-glucose-tolerance tests, support this argument (19). Thus, nonidentification of subjects with IGT in this study may have led to underestimates of the association of betel-quid chewing with hyperglycemia. The marked association of hypertriacylglycerolemia with betel chewing may reflect a particular sensitivity of adipose tissue, its hormonal axis or autonomic nerve supply, to betel-quid chewing toxicity.

The history of metabolic syndrome in first- and second-degree relatives was included in analysis because family aggregation of the metabolic syndrome could be conferred by both genetic factors and shared environmental and lifestyle factors. However, limiting family history to first-degree relatives did not affect the findings.

A major strength of the present cross-sectional study was that it was population-based and large enough to enable us to examine associations between betel-quid chewing and the components of the metabolic syndrome after adjusting for a constellation of risk factors known to increase the prevalence of the metabolic syndrome and to look for the dose-response effects found that support the possibility of a causal relation between betel consumption and the metabolic syndrome suggested by studies in the CD1 mouse (2). Although these findings suggest that betel-quid chewing contributes to the development of the metabolic syndrome and hence to the burden of diabetes and vascular disease causality, causality cannot be demonstrated in cross-sectional studies such as this. The contribution of the betel habit to human disease should, therefore, be assessed by further prospective studies.

Confirmation of causality would enhance the importance of primary prevention and cessation programs for this habit, already important health targets in user populations for the reduction of cancer risks (3, 6), and might reduce the burden of metabolic syndrome-related disease in the 600 million people currently chewing betel nut worldwide (1).

In conclusion, significant associations were shown between betel nut (*Areca catechu*) chewing and metabolic syndrome risk in a male population with a 15.1% prevalence of betel-quid chewing, which matched experimental findings in mice. Dose-response effects of betel use (eg, on the duration of use, rate of use, cumulative exposure, and quitting years) in relation to the risk of the metabolic syndrome support this finding. However, prospective studies are required to confirm these findings because betel-quid chewing cessation programs, already being developed to reduce the incidence of oropharyngeal cancer, could lead to a reduction in metabolic syndrome-related disease in the 10% of the world population ( $\approx 600$  million people) currently chewing betel quid.

We are indebted to our colleagues in the Bureau of Health in Keelung City for implementing the Keelung Community-based Integrated Screening program, which provided the screening results for participants that formed the basis of the current study. The manuscript is identified as KCIS no. 13.

AM-FY helped with the data retrieval, data analysis, and writing of the draft. Y-HC assisted with the data collection and interpretation of results. L-SC, H-MW, and C-CH participated in the data retrieval, data management, and interpretation of results. BJB contributed to the concepts investigated, writing of the draft, interpretation of the results, and the writing of the manuscript. TH-HC synthesized the analyses and headed the writing of the manuscript. All authors approved the final version of the text. None of the authors had a conflict of interest.

## REFERENCES

- IARC Working Group on the Evaluation of Carcinogenic Risks to Humans. Betel-quid and areca-nut chewing and some areca-nut-derived nitrosamines. IARC Monogr Eval Carcinog Risks Hum 2004;85:1-334.
- Boucher BJ, Ewen SWB, Stowers JM. Betel nut (*Areca catechu*) consumption and the induction of glucose intolerance in adult CD1 mice and in their F1 and F2 offspring. Diabetologia 1994;37:49-55.
- Tung TH, Chiu YH, Wu HM, Boucher BJ, Chen THH. A population-based study of the association between areca-nut chewing and type 2 diabetes mellitus in men. Diabetologia 2004;47:1776-81. (KCIS no. 2.)
- Boucher BJ, Mannan N. Metabolic effects of the consumption of *Areca catechu*. Addict Biol 2002;7:103-10.
- Mannan N, Boucher BJ, Evan SJW. Increased waist size and weight in relation to consumption of *Areca catechu* (betel-nut); a risk factor for increased glycemia in Asians in East London. Br J Nutr 2000;83:267-75.
- Hung DZ, Deng JF. Acute myocardial infarction temporally related to betel nut chewing. Vet Hum Toxicol 1998;40:25-8.
- Gupta PC, Warnakulasuriya S. Global epidemiology of *Areca* nut usage. Addict Biol 2002;7:77-83.
- Chen THH, Chiu YC, Luh DL, et al. Taiwan Community-based Integrated Screening Group. Community-based multiple screening model: design, implementation, and analysis of 42,387 participants. Cancer 2004;100:1734-43.
- Expert Panel on Detection, Evaluation, and Treatment of High Blood Cholesterol in Adults. Executive summary of the third report of the National Cholesterol Education Program (NCEP) Expert Panel on Detection, Evaluation, and Treatment of High Blood Cholesterol in Adults (Adult Treatment Panel III). JAMA 2001;285:2486-97.
- World Health Organization. The Asia-Pacific perspective: redefining obesity and its treatment. Geneva, Switzerland: WHO, 2000.
- Doll R. Comparison between registers, age-standardised rates. IARC Sci Publ 1976;3:453-9.
- Boucher BJ. Inadequate vitamin D status; does it contribute to the disorders comprising syndrome 'X'? Br J Nutr 1998;79:315-27.
- Bonner-Weir S, Leahy JL, Weir GC. Induced rat models of non-insulin dependent diabetes. In: Shafir E, Renold AE, eds. Lessons from animal diabetes. 2: Frontiers in diabetes research. London, United Kingdom: Libby, 1988.
- Helgesen T, Ewen SWB, Jaffrey B, et al. *N*-Nitrosamines in smoked meats and their relation to diabetes. IARC Sci Publ 1984;57:911-20.
- Portha B, Giroix MH, Cros JC, et al. Diabetogenic effect of *N*-nitrosomethylurea and *N*-nitrosomethylurethane in the adult rat. Ann Nutr Aliment 1980;34:1143-51.
- Karam JH, Lewitt PA, Young CW, et al. Insulinopenic diabetes after Rodenticide (Vacor) ingestion. Diabetes 1980;29:971-88.
- Li CL, Tsai ST, Chou P. Comparison of metabolic risk profiles between subjects with fasting and 2-hour plasma glucose impairment: The Kinmen Study. J Clin Epidemiol 2002;55:19-24.
- Li CL, Tsai ST, Chou P. Relative role of insulin resistance and beta-cell dysfunction in the progression to type 2 diabetes—The Kinmen Study. Diabetes Res Clin Pract 2003;59:225-32.
- Anand SS, Razak F, Vuksan V, et al. Diagnostic strategies to detect glucose intolerance in a multiethnic population. Diabetic Care 2003;26:290-6.



# Transgenerational effects of betel-quin chewing on the development of the metabolic syndrome in the Keelung Community-based Integrated Screening Program<sup>1-4</sup>

Tony H-Hsi Chen, Yueh-H Chiu, and Barbara J Boucher

## ABSTRACT

**Background:** The transgenerational metabolic effects of betel-quin chewing have been reported in mice but not in humans.

**Objective:** This study aimed to determine whether exposure to paternal chewing of betel nut quids led to an increased risk of early manifestation of the metabolic syndrome (MetS) in human offspring.

**Design:** The subjects were selected from 66 971 residents aged >19 y who attended a community-based Integrated Screening Program in Taiwan and who were identified as parent-child trios ( $n = 5037$ ). Using a population-based, parent-child study design, we compared the mean ages of offspring with MetS at entry between those who were exposed and those who were unexposed to paternal chewing of quids containing betel nut. Cox proportional hazards regression models were used to estimate adjusted hazard ratios and to assess dose-response relations for paternal betel-quin exposure.

**Results:** The offspring who were exposed to paternal betel-quin chewing were younger than those who were not exposed, regardless of MetS status; they also had a 2.14-fold increase in the risk of early manifestation of MetS (adjusted hazard ratio = 2.14; 95% CI: 1.25, 3.66) after control for environmental and other risk factors, including personal betel chewing. Significant dose-response relations were found between the risk of early MetS and the quantity and duration of paternal exposure to betel quids. In the absence of MetS in either parent and of betel-quin consumption by the offspring, paternal exposure to betel quids increased the risk of early manifestation of MetS in offspring 2.53-fold (95% CI: 1.03, 2.64) compared with paternal nonexposure.

**Conclusion:** Our findings suggest that exposure to paternal betel-quin chewing increases the risk of early manifestation of MetS in human offspring in a dose-dependent manner. *Am J Clin Nutr* 2006;83:688-92.

**KEY WORDS** *Areca catechu*, betel, metabolic syndrome, transgenerational effect, Taiwan, paternal, humans

## INTRODUCTION

In addition to the established causal relation between betel-quin (paan) chewing and oral cancer, which is independent of chewing tobacco use (1), the effect of this habit on chronic diseases has gained increasing attention over the past decade. Evidence suggesting an independent role of betel-quin chewing in the development of type 2 diabetes has been shown in 2 population-based studies conducted in humans, one conducted in Taiwan (2) and the other conducted in Papua New Guinea (3). In

addition to type 2 diabetes, betel-quin use has also been associated with increases in heart rate, blood pressure, waist size, cholesterol and triacylglycerol concentrations, and body weight (4-7). A previous experimental study in CD1 mice showed that paternal exposure to betel nut (*Areca catechu*) transmits an increased risk of hyperglycemia to non-betel fed first generation offspring, especially male offspring. Furthermore, this effect was independent of paternal or maternal hyperglycemia (8). However, no studies have, to date, investigated the possibility of similar inheritance of betel-quin diabetogenicity in humans. Whether the inheritance of betel-quin effects is limited to diabetes or may also apply to other features of the metabolic syndrome (MetS) associated with cardiovascular disease remains in question (4, 6).

We recently found strong associations between betel-quin consumption (independent of tobacco use) and features of MetS, including its diabetogenicity, in a community-based study (2). This led us to test the hypothesis of whether exposure to paternal betel-quin chewing increases the risk of early development of features of MetS in human offspring.

## SUBJECTS AND METHODS

### Study subjects and design

Data used in the present study were obtained from an on-going community-based multiple screening program named the Keelung community-based integrated screening (KCIS) program, which is conducted in Keelung, the northernmost county of Taiwan. The KCIS study, which is run by the Health Bureau of Keelung City, has been in progress from the beginning of 1999 and has ethical approval from the local health committee. The

<sup>1</sup> From the Institute of Preventive Medicine, College of Public Health, National Taiwan University, Taipei, Taiwan (TH-HC); the Institute of Health Informatics and Decision Making, School of Medicine, National Yang-Ming University, Taipei, Taiwan (Y-HC); and the Centre for Diabetes and Metabolic Medicine, Queen Mary School of Medicine and Dentistry, University of London, Royal London Hospital, London, United Kingdom (BJB).

<sup>2</sup> KCIS paper no. 8.

<sup>3</sup> Supported by the National Science Council, Taiwan.

<sup>4</sup> Reprints not available. Address correspondence to BJ Boucher, Centre for Diabetes and Metabolic Medicine, Royal London Hospital, London E11BB, United Kingdom. E-mail: bboucher@doctors.org.uk.

Received August 12, 2005.

Accepted for publication December 5, 2005.

details of the study design, implementation, early findings, financial sources, and different committees have been described in full elsewhere (9). In brief, the KCIS program was originally designed to invite women who had not had a Pap test during the 3 y preceding the start of the program for screening for factors relating to 5 neoplastic diseases and 3 nonneoplastic diseases; other family members were also invited to participate. Of the total population of Keelung, 66 971 residents (23%) aged  $\geq 20$  y gave written informed consent, attended the KCIS program, and had been screened by December 2003.

Because the KCIS program was implemented on a family basis, the dataset provides an opportunity to explore the transgenerational effects of betel-quinid consumption on MetS with the use of a family parent-offspring study design nested within the 66 971 subjects. This cohort contained 12 138 subjects with and 54 833 subjects without MetS. By linking the screening dataset with the population registry that recorded the parents' name for each resident, we could identify 10 566 parent-child trios. After exclusion of incomplete parent-child trios (when a parent, both parents, or the offspring had not participated in the KCIS program), we confirmed 5037 parent-child trios eligible for inclusion in the planned analyses.

### Exposure and outcome

Because we were interested in the transgenerational effects of parental betel-quinid chewing on the risk of MetS, the definition of MetS was central to the study and was made according to the modified National Cholesterol Education Program Adult Treatment Panel III criteria (10), ie, when abnormalities were present in  $\geq 3$  of the following criteria: waist size  $>80$  cm in women or  $>90$  cm in men, serum triacylglycerol concentrations  $>150$  mg/dL, HDL cholesterol  $<50$  mg/dL (1.29 mmol/L) in women or  $<40$  mg/dL ( $<1.04$  mmol/L) in men, blood pressure  $>130$  mm Hg (systolic) or  $>85$  mm Hg (diastolic), fasting blood glucose  $>110$  mg/dL ( $>6.1$  mmol/L), and a body mass index (in  $\text{kg}/\text{m}^2$ )  $>25$ . Data for the 5 variables used in this definition of MetS (10) were collected during the subjects' on-site screening. Weight, height, waist and hip circumferences, and blood pressure were measured with standard techniques by trained staff; a venous blood sample was taken after the subjects had fasted 12 h overnight for the measurement of plasma glucose, triacylglycerol, total cholesterol, HDL-cholesterol, LDL-cholesterol, and uric acid concentrations.

Information on betel-quinid consumption, smoking and alcohol habits, physical activity, dietary factors, and educational levels was collected by face-to-face interviews during the on-site screening. Both duration (in y) and quantity (no. of portions chewed/d) of betel-quinid usage were recorded. Two specific points should be noted. First, because few mothers had been exposed to betel quinid (0.8%), only the relations of outcome to paternal exposure could be analyzed, and the effects of maternal exposure were not investigated further. Second, because fathers may have started chewing betel quids only after the birth of the index child, the duration of paternal exposure before birth of the index child was calculated as the difference between the age of the father at entry to the study (minus age at commencement of betel-quinid chewing) and the age of the index offspring at entry to the study. Duration of paternal exposure to betel quinid was examined in relation to age in offspring who were diagnosed with MetS after 5 male offspring were excluded from the analysis because paternal betel chewing had begun only after their birth.

The cumulative exposure of fathers to betel-nut chewing was calculated as the number of portions chewed/d  $\times$  the duration of chewing.

### Statistical methods

The primary outcome measurement was the age of the offspring who were found to have MetS, as defined by  $\geq 3$  of the component abnormalities, whether newly diagnosed or previously recognized. We first used multiple linear regression models to test whether there was any interaction between the differences in the mean age of offspring at recruitment (stratified by MetS status) and sex and paternal exposure to betel chewing. Because the offspring without MetS at entry may not have known whether they had MetS or when it developed (if MetS was found to be present), we used Cox proportional hazards regression models to estimate hazard ratios (HRs) and their 95% CIs, with age at entry as "survival time" and regarding the status of those who were free of MetS at entry as "censored" compared with the "uncensored" status of those found to have MetS at entry.

To assess whether the effect of exposure to paternal betel chewing as a risk factor for the development of MetS in the offspring varied with sex, an interaction assessment was performed with the use of the interaction variable (paternal exposure  $\times$  offspring sex) in Cox regression modeling. The findings were then tested for independence of exposure to paternal betel consumption as a predictor of risk of development of MetS by using a univariate analysis (Cox regression model) with control for all of the confounders identified as significant ( $P < 0.05$ ).

Dose-response effects for quantity, duration, and cumulative exposure to betel chewing were each evaluated by using trend tests. Models incorporating quantity, duration, or cumulative paternal exposure as ordinal variables together with potential confounding factors [sex, vegetable consumption ( $>3$  or  $\leq 3$  portions/meal), exercise (sedentary or regular), paternal and maternal MetS status, and personal betel chewing by offspring] were compared with models that included only the potential confounding factors identified as significant with likelihood ratio testing. Departure from linearity was then examined with respect to quantity, duration, or cumulative paternal exposure in a comparison, in each case, of models that included quantity, duration, or cumulative exposure of paternal betel use as an ordinal variable with models that included quantity, duration, or cumulative exposure of paternal betel use as a categorical property with likelihood ratio testing. All statistical analyses were performed with SAS version 9.1 (SAS Institute, Cary, NC).

### RESULTS

The findings for age and for the variables relevant to MetS in fathers, mothers, and offspring are shown in **Table 1**. Regardless of MetS status, the offspring who were exposed to paternal betel-quinid chewing were younger than the offspring who were not exposed to paternal betel chewing [mean ( $\pm$ SD) age:  $30.92 \pm 8.32$  compared with  $38.16 \pm 8.0$  y]. The significant confounding factors for the presence of MetS that were identified in the offspring were vegetable consumption, personal betel chewing by the offspring, and parental MetS status; no significant interactions were found between personal betel chewing and abnormalities in any variables that were used to define MetS in the offspring. These significant confounding factors, together with paternal betel habits, were then used in a multivariate analysis to

TABLE 1

Descriptive data for metabolic syndrome (MetS)-defining variables in fathers, mothers, and offspring with and without MetS at entry to the study<sup>1</sup>

	Age	Waist	BMI	Glucose	SBP	DBP	Triacylglycerol	HDL cholesterol
	y	cm	kg/m <sup>2</sup>	mg/dL	mm Hg	mm Hg	mg/dL	mg/dL
<b>MetS</b>								
Father (n = 940)	64.2 ± 8.7 <sup>2</sup>	94.0 ± 7.5	27.3 ± 3.0	121.4 ± 49.9	144.7 ± 19.1	86.4 ± 11.6	226.6 ± 131.1	42.9 ± 10.3
Mother (n = 798)	62.3 ± 7.9	85.9 ± 8.1	27.3 ± 3.5	122.7 ± 50.2	141.9 ± 20.9	83.9 ± 12.6	206.8 ± 112.6	50.0 ± 11.8
Offspring								
Male (n = 260)	37.9 ± 8.1	93.4 ± 8.3	28.4 ± 3.4	96.1 ± 30.8	139.3 ± 15.7	88.4 ± 13.9	270.5 ± 147.5	39.3 ± 8.3
Female (n = 131)	39.6 ± 7.7	84.4 ± 7.7	28.1 ± 3.4	100.2 ± 29.1	132.2 ± 15.9	85.1 ± 10.7	206.3 ± 118.5	44.9 ± 7.7
<i>P</i> <sup>3</sup>		<0.0001	0.4961	0.1994	<0.0001	0.0090	0.0035	<0.0001
<b>MetS absent</b>								
Father (n = 2736)	63.8 ± 8.9	84.1 ± 8.6	24.2 ± 3.1	94.3 ± 25.5	134.2 ± 20.7	81.8 ± 12.1	114.5 ± 74.0	54.5 ± 12.6
Mother (n = 2096)	57.9 ± 8.3	77.0 ± 8.8	24.6 ± 3.4	92.4 ± 21.9	126.9 ± 20.2	78.2 ± 11.5	106.1 ± 59.6	62.2 ± 13.5
Offspring								
Male (n = 1956)	34.3 ± 8.1	80.3 ± 8.6	23.9 ± 3.4	85.9 ± 12.9	123.5 ± 16.2	77.9 ± 11.3	118.7 ± 80.6	52.4 ± 11.0
Female (n = 2690)	33.8 ± 8.2	69.3 ± 7.8	21.9 ± 3.3	84.9 ± 12.1	110.9 ± 14.4	71.5 ± 9.9	77.7 ± 43.8	61.9 ± 12.8
<i>P</i> <sup>4</sup>		<0.0001	<0.0001	0.0098	<0.0001	<0.0001	<0.0001	<0.0001
<i>P</i> of interaction <sup>5</sup>		0.0912	0.7398	0.2268	0.0182	0.1303	0.6089	0.1364
<i>P</i> of interaction <sup>6</sup>		0.0256	<0.0001	0.0017	0.0013	0.0101	0.0179	0.0043
<i>P</i> of interaction <sup>7</sup>		0.0017	<0.0001	0.2557	0.5407	0.0919	0.3331	0.0248

<sup>1</sup> SBP, systolic blood pressure; DBP, diastolic blood pressure.<sup>2</sup>  $\bar{x} \pm$  SD (all such values).<sup>3</sup> *t* Test comparing the findings between male and female offspring with MetS.<sup>4</sup> *t* Test comparing the findings between male and female offspring without MetS.<sup>5</sup> Interaction in parents between sex of parent and MetS status in their offspring; identified by using linear regression modeling.<sup>6</sup> Interaction between sex of offspring and MetS status of offspring; identified by using linear regression modeling.<sup>7</sup> Interaction between MetS status, sex, and generation; identified by using linear regression modeling.

calculate adjusted HRs with the use of stepwise multiple regression analysis (to  $P < 0.05$ ) for these factors in the offspring. The HRs for the risk of MetS in the offspring with relation to paternal betel use, both unadjusted and after adjustment for potential confounding factors, are shown in Table 2. The offspring who were exposed to paternal betel-quid chewing had a 2-fold (unadjusted HR = 2.08; 95% CI: 1.22, 3.56) increase in the risk of early manifestation of MetS compared with those who were not exposed. The increased risk of early manifestation of MetS in the offspring who were exposed to paternal betel-quid chewing persisted after adjustment for confounding variables (adjusted HR = 2.14; 95% CI: 1.25, 3.66). The findings for each of the MetS-defining variables were similar, except for hyperglycemia [HRs (95% CI) for abnormality in waist, triacylglycerol, HDL cholesterol, blood pressure, and glycemia were 1.77 (1.17, 2.66), 2.42 (1.7, 3.43), 2.48 (1.77, 3.46), 2.36 (1.8, 3.09), and 1.01 (0.25, 4.13), respectively].

The HRs and dose-response relations between the risk of early manifestation of MetS in offspring and the quantity, duration, and cumulative exposure of fathers to betel quid, after adjustment for significant confounders including parental MetS, are shown in Table 3. The dose effects on consumption rates, duration of use, and cumulative exposure found for paternal betel chewing were significant. Except for cumulative exposure ( $P < 0.0001$ ), these relations were linear (Table 3). However, the results for cumulative exposure have to be interpreted with caution because the numbers of fathers in the highest category of cumulative exposure was small and may have distorted the estimates.

Three important confounding factors (the presence of maternal MetS, the presence of paternal MetS, and the habit of chewing

betel quid in the offspring) for occurrence of MetS were allowed for by additional analyses of the data after stratification by each of these variables. The offspring who were exposed to paternal betel chewing in the absence of any of these 3 confounders had a 2.53-fold (95% CI: 1.03, 2.64) increase in the risk of early development of MetS compared with those who were not exposed.

## DISCUSSION

Our findings, which are based on a population-based, parent-child family study, strongly suggest that exposure to paternal betel-quid chewing leads to a significantly earlier appearance of MetS in human offspring. This postulate is supported by 3 major findings: 1) the 2-fold increase in the risk of early development of MetS in offspring whose fathers had chewed betel quids (after control for environmental risk factors, parental MetS, and betel-quid consumption in offspring); 2) the significant dose-response relations for both the quantity and the duration of paternal betel-quid chewing and for cumulative paternal exposure to betel quid before the birth of the offspring; and 3) the independent 2.53-fold increase in the risk of early development of MetS in the non-betel chewing offspring of parents without MetS but with betel-chewing fathers.

The use of a parent-child family study design based on a community-based integrated screening study has several advantages, including the assessment of both parents and offspring with respect to the diagnosis of MetS at the same time rather than relying on self-reports of MetS in parents by the offspring, as is common in conventional epidemiologic studies. Similarly, the

TABLE 2

Estimated crude and adjusted hazard ratios (HRs) for the metabolic syndrome (MetS) for paternal exposure to betel quid and for confounding factors associated with MetS

Variable	MetS/non-MetS <i>n</i>	Crude HR (95% CI)	Adjusted HR (95% CI) <sup>1</sup>
<b>Paternal betel-quid chewing</b>			
Never	377/4448	1.00	1.00
Current and ex chewers	14/198	2.08 (1.22, 3.56) <sup>2</sup>	2.14 (1.25, 3.66) <sup>2</sup>
<b>Confounding variables</b>			
<b>Sex</b>			
Female	131/2690	1.00	1.00
Male	260/1956	2.33 (1.89, 2.87) <sup>3</sup>	2.03 (1.62, 2.54) <sup>3</sup>
<b>Education</b>			
High	185/2193	1.00	
Low + middle	202/2353	0.92 (0.73, 1.15)	
<b>Exercise</b>			
Sedentary	164/1456	1.00	1.00
Usually	222/2957	0.65 (0.53, 0.79) <sup>4</sup>	0.74 (0.60, 0.90) <sup>2</sup>
<b>Vegetable intake</b>			
Infrequent	328/3246	1.00	1.00
Frequent	59/1341	0.47 (0.36, 0.63) <sup>4</sup>	0.58 (0.44, 0.77) <sup>2</sup>
<b>Coffee intake</b>			
Infrequent	220/2794	1.00	
Frequent	163/1781	1.09 (0.89, 1.33)	
<b>Betel-quid chewing of offspring</b>			
Never	312/4196	1.00	1.00
Current and ex chewers	76/390	2.62 (2.04, 3.37) <sup>3</sup>	1.79 (1.36, 2.35) <sup>4</sup>
<b>Paternal MetS</b>			
No	244/3508	1.00	1.00
Yes	147/1138	1.65 (1.35, 2.03) <sup>3</sup>	1.65 (1.34, 2.03) <sup>4</sup>
<b>Maternal MetS</b>			
No	241/3653	1.00	1.00
Yes	150/993	1.37 (1.10, 1.71) <sup>4</sup>	1.26 (1.02, 1.55) <sup>4</sup>

<sup>1</sup> Analyzed by using Cox regression modeling; adjusted for each of the other variables that had a significant ( $P < 0.05$ ) effect on the risk of MetS. There were no significant sex of offspring  $\times$  chewing interactions for any of the confounding variables, apart from education ( $P = 0.046$ ).

<sup>2-4</sup> Significantly different from reference: <sup>2</sup>  $P < 0.01$ , <sup>3</sup>  $P < 0.0001$ ; <sup>4</sup>  $P < 0.05$ .

direct assessment of betel-quid habits in parents and offspring were made at the same time, as was the assessment of environmental factors related to the risk of MetS that were controlled for in the model.

The evidence for transmission of the risk of hyperglycemia from parents to offspring is weaker than for other features of MetS. This could reflect the relative young age (<40 y) of the offspring studied, because fasting glycemia has been shown to be

TABLE 3

Adjusted hazard ratios (HRs) and dose-response relations, in terms of quantity, duration, and cumulative exposure, for the association of paternal betel-quid chewing with risk of the metabolic syndrome (MetS) in offspring

Dose-response	MetS/non-MetS <i>n</i>	HR (95% CI) <sup>1</sup>	<i>P</i> for trend	<i>P</i> for departure from linearity
<b>Quantity (quids/d)</b>				
None	377/4448	1.00	<0.0001	0.6783
1-5 quids	4/101	1.44 (0.54, 3.87)		
6-15 quids	3/54	2.32 (0.95, 5.64)		
>15 quids	7/43	2.52 (1.04, 6.12)		
<b>Duration of betel-quid chewing</b>				
0	377/4448	1.00	<0.0001	0.5491
1-5 y	4/86	1.31 (0.42, 4.11)		
6-15 y	7/93	3.41 (1.51, 7.69) <sup>2</sup>		
>15 y	3/19	6.31 (0.87, 45.57)		
<b>Cumulative exposure</b>				
0	377/4448	1.00	<0.0001	<0.0001
<5 $\times$ 10 <sup>4</sup> betel quid-d	4/80	1.74 (0.43, 7.05)		
5-15 $\times$ 10 <sup>4</sup> betel quid-d	8/86	5.48 (1.72, 17.44) <sup>2</sup>		
>15 $\times$ 10 <sup>4</sup> betel quid-d	2/32	1.89 (0.71, 5.09)		

<sup>1</sup> Cox proportional hazard regression models were used to estimate adjusted HRs and their 95% CIs for quantity of quids used per day, duration of chewing, and cumulative exposure after control for other factors that significantly affected MetS risk in offspring [HR (95% CIs) for each factor— paternal MetS: 1.62 (1.32, 2.00); betel quid chewing by offspring: 1.77 (1.35, 2.32); vegetable consumption: 0.58 (0.44, 0.77), and exercise: 0.74 (0.60, 0.91)]. There were no significant sex of offspring  $\times$  chewing interactions.

<sup>2</sup> Significantly different from reference,  $P < 0.01$ .

1223

relatively weak for the detection of sustained hyperglycemia and type 2 diabetes in previous studies conducted in Taiwan. A comparison of impaired fasting plasma glucose (IFG) according to the American Diabetes Association criteria (5.6–7.8 mmol glucose/L) with impaired glucose tolerance (IGT) according to World Health Organization criteria showed that in 50% of subjects who were diagnosed according to the American Diabetes Association criteria will have undiagnosed diabetes and 68% will have IGT according to the World Health Organization criteria (11). Similarly, the overlap between IFG and IGT was present in only 21% of Taiwanese subjects in a study that examined the relation of IFG and of IGT to cardiovascular disease risk profiles; thus, if IFG alone was used for screening glucose tolerance, 67% of subjects with IGT and an abnormal cardiovascular disease risk profile would have been undetected (12). Similar findings, which suggested that type 2 diabetes may be a late feature of MetS in the Taiwanese population, were reported by Anand et al (13). Our study shows that the prevalence of MetS-defining increases in fasting glucose was indeed higher in parents (18% in mothers and 17.2% in fathers) than in their offspring (2.9% in males and 1.8% in females).

Several biological explanations could account for the trans-generational effect of betel-quid chewing on the risk of early development of MetS. First, genetic changes occur after damage to nuclear DNA by the specific and carcinogenic arecal nitrosamines that are formed in the nut, in the mouth, and during digestion from the alkaloids found in the betel (*Areca catechu*) nut (1, 14). Support for this possibility includes an increase in chromosomal aberrations and micronucleated cells in peripheral blood mononuclear cells of adult betel-quid chewers (15). Additionally, remarkable increases in abnormal sperm morphology were seen in mice that were fed arecoline or pan masala (an aromatic chew containing betel nut) and in the sperm of human pan masala consumers (14–16). Furthermore, several nitrosamines similar to the arecal nitrosamines, such as the nitroso-compound streptozocin, are known to induce type 1 diabetes experimentally and can induce non-insulin dependent diabetes at low dosages in young animals (17). Because the production of gametes is a continuous process in men during their reproductive life, and women in Taiwan rarely chew betel, the betel-related factor responsible might be expected to affect the forming spermatozoa, but not oocytes, in our study population. The predominance of the transmission of MetS risk by betel chewing fathers to male offspring, rather than female offspring, in mice suggests that any betel nut-related genetic damage might be limited to the Y chromosome; but whether this applies in humans awaits additional investigation as more of the subjects in this survey develop MetS with age. Epigenetic phenomenon, such as increased methylation of DNA as a result of exposure to the free radical cascades generated by the specific arecal nitrosamines (1), could also account for our findings. However, it may not be possible to identify the genetic or epigenetic effects that may lead to the transmission of MetS risk in a cohort of offspring as young as those whom we studied, because not all affected persons will have manifested MetS yet.

In conclusion, our study showed that exposure to paternal betel-quid chewing is associated with dose-dependent increases in the risk of developing MetS in offspring at an earlier age than is seen in the offspring of non-betel-quid chewing fathers. Ten percent of the world's population, ≈600 million people, chews

betel nut (*Areca catechu*) (1). Identification of the mechanisms underlying our findings is warranted because they might, similar to other epigenetic phenomena, prove to be reversible. **□**

The authors are grateful for grant support from the National Science Council and for the technical, nursing, and community worker assistance and support of Po-En Wang and Ting-Ting Wang (Health Bureau of Keelung City).

TH-HC contributed to the conceptual design of the study, collection and analysis of the data, and interpretation and writing of the manuscript. Y-HC contributed to the collection of data, statistical analysis, and interpretation of the manuscript. BJB contributed intellectually to the concepts investigated and both intellectually and practically to the preparation of the final text. All authors reviewed and agreed to the final manuscript. The authors had no conflicts of interest.

## REFERENCES

1. IARC. Monographs on the evaluation of carcinogenic risk of chemicals to humans. Lyons, France: International Agency for Research on Cancer, 1992;85:80–112.
2. Tung TH, Chiu YH, Chen LS, Wu HM, Boucher BJ, Chen THH. A population-based study of the association between Areca-nut chewing and Type 2 diabetes mellitus in men (Keelung Community-based Integrated Screening Programme No. 2). *Diabetologia* 2004;47:1776–81.
3. Benjamin AL. Community screening for diabetes in the National Capital District, Papua New Guinea: is betel nut chewing a risk factor for diabetes? *Papua New Guinea Medical J* 2001;44:101–7.
4. Boucher BJ, Mannan N. Metabolic effects of the consumption of *Areca catechu*. *Addict Biol* 2002;7:103–10.
5. Mannan N, Boucher BJ, Evans JW. Increased waist size and weight in relation to consumption of *Areca catechu* (betel-nut); a risk factor for increased glycaemia in Asians in East London. *Br J Nutr* 2000;83:267–75.
6. Chou P, Hsiao KJ, Lin JWH, Chen ST. Community-based survey on blood pressure, blood biochemistry and dietary habits in Pu-Li, Taiwan. *Chin Med J (Taipei)* 1992;50:279–87.
7. Lin SK, Chang YJ, Ryu SJ, Chu NS. Cerebral hemodynamic responses to betel chewing: a Doppler study. *Clin Neuropharmacol* 2002;25:244–50.
8. Boucher BJ, Ewen SWB, Stowers JM. Betel nut (*Areca catechu*) consumption and the induction of glucose intolerance in adult CD1 mice and in their F1 and F2 offspring. *Diabetologia* 1994;37:49–55.
9. Chen THH, Chiu YH, Luh DL, et al. Community-based multiple screening model. *Cancer* 2004;100:1734–43.
10. Cleeman JI. Executive summary of the third report of the national cholesterol education program (NCEP) expert panel on detection, evaluation, and treatment of high blood cholesterol in adults (Adult Treatment Panel III). *JAMA* 2001;285:2486–97.
11. Li CL, Tsai ST, Chou P. Comparison of the results between two diagnostic criteria by ADA and WHO among subjects with FPG 5.6–7.8 mmol/l in Kin-Hu and Kin-Chen, Kinmen, 1991–94. *Diabetes Res Clin Pract* 1999;45:51–9.
12. Li CL, Tsai ST, Chou P. Comparison of metabolic risk profiles between subjects with fasting and 2-hour plasma glucose impairment: The Kinmen Study. *J Clin Epidemiol* 2002;55:19–24.
13. Anand SS, Razak F, Vuksan V, et al. Diagnostic strategies to detect glucose intolerance in a multiethnic population. *Diabetes Care* 2003;26:290–6.
14. Dave BJ, Trivedi AH, Adhvaryu SG. Cytogenetic studies reveal increased genomic damage among pan masala consumers. *Mutagenesis* 1991;6:159–63.
15. Sinha A, Rao AR. Induction of shape abnormality and unscheduled DNA synthesis by arecoline in the germ cells of mice. *Mutat Res* 1985;158:189–92.
16. Kumar S, Nigam SK, Shaikh SA, Saiyed HN. Effect of pan masala on sperm morphology of a mouse. *Bull Environ Contam Toxicol* 2003;70:1184–8.
17. Portha B, Serradas P, Blondel O, Giroix MH, Bailbe D. Relation between hyperglycemia and impairment of insulin secretion and action. Information from the n-STZ rat models. In: Shafir E, ed. *Frontiers in diabetes research. Lessons from animal diabetes* 111. London, United Kingdom: Smith-Gordon and Co Ltd, 1990:334–41.



## ORIGINAL ARTICLE

# Betel nut chewing and other risk factors associated with obesity among Taiwanese male adults

W-C Chang<sup>1</sup>, C-F Hsiao<sup>2</sup>, H-Y Chang<sup>3</sup>, T-Y Lan<sup>1</sup>, C-A Hsiung<sup>2</sup>, Y-T Shih<sup>3</sup> and T-Y Tai<sup>1</sup>

<sup>1</sup>Division of Gerontology Research, National Health Research Institutes, Taipei City, Taiwan; <sup>2</sup>Division of Biostatistics and Bioinformatics Research, National Health Research Institutes, Taipei City, Taiwan and <sup>3</sup>Division of Health Policy Research, National Health Research Institutes, Taipei City, Taiwan

**Objective:** The research aimed at examining betel nut chewing and other risk factors associated with obesity among Taiwanese male adults.

**Design:** The research analyzed the data obtained by the 2001 National Health Interview Survey in Taiwan that covered all the administrative divisions in Taiwan. Multistage stratified systematic sampling design was adopted for survey. All members of a sampled household received the interview.

**Subjects:** The research analyzed questionnaires answered by nonaboriginal male respondents aged between 20 and 59 years old, and the total number of samples analyzed read 6126. Since very few female subjects chewed betel nut, they were excluded from the analysis.

**Measurements:** Criteria of obesity was defined as body mass index  $\geq 27$  kg/m<sup>2</sup>. The variables incorporated for analysis included the respondents' status of betel nut chewing, age, educational background, presence of hypertension and diabetes mellitus, drinking and smoking status, exercise status, and demand for physical strength at job. Generalized estimating equations model was employed to estimate the odd ratios (with 95% CI) of obesity of each independent variable.

**Results:** Approximately 16.2% of respondents were obese. The distribution of betel nut chewing was current chewers 15.9%, ex-chewers 4.3%, and nonchewers 79.8%. After controlling above-mentioned independent variables, hypertension, diabetes mellitus, betel nut chewing, never exercising, and sedentary jobs were closely associated with obesity.

**Conclusion:** The research found that betel nut chewing closely associated with obesity. The increased appetite of betel nut chewers is speculated as the underlying cause. The prospective study is needed to clarify this issue. In addition to increasing the risk of developing oral cancer, betel nut chewing seemed to be related with another health hazard: obesity.

*International Journal of Obesity* (2006) 30, 359–363. doi:10.1038/sj.ijo.0803053; published online 23 August 2005

**Keywords:** betel nut; BMI; Taiwan; male

### Introduction

According to the latest statistics published by the Directorate General of Budget, Accounting and Statistics, Executive Yuan, Taiwan has marched into a developed country with an average GNP of US\$13 995. Together with the economic growth, the prevalence of obesity among Taiwanese adults has also exceeded 10%.<sup>1</sup> The purpose of this study was to explore the risk factors associated with obesity in Taiwan. In addition to various commonly reported risk factors, betel nut chewing was also included.

Betel nut chewing, a special habit popular among residents in South and Southeast Asia,<sup>2,3</sup> is generally believed to be a risk factor of developing oral cancer.<sup>2,4–7</sup> Betel nut contains unique alkaloid, and its major constituents – arecoline and arecaidine – are capable of inhibiting  $\gamma$ -aminobutyric acid (GABA) receptor.<sup>8</sup>

The previous researches suggest that betel nut chewing can increase body mass index (BMI)<sup>9</sup> or contribute to central obesity.<sup>10</sup> Obesity is an important risk factor for a legion of chronic diseases, such as diabetes mellitus, cardiovascular diseases, and hypertension.<sup>11–17</sup> However, the number of researches studying the relationship between betel nut chewing and body size remains fairly limited. As Taiwan is marked by a high prevalence rate of betel nut chewing<sup>18</sup> and has witnessed an increasing incidence of the above-mentioned chronic diseases, our research has accordingly examined the relationship between betel nut chewing and body build.

Correspondence: Dr T-Y Tai, Division of Gerontology Research, National Health Research Institutes, Room 4110, 4F, No. 161, Sec. 6, Mincyuan E. Rd, Neihu District, Taipei City 114, Taiwan.

E-mail: tytai@nhri.org.tw

Received 24 March 2005; revised 10 June 2005; accepted 5 July 2005; published online 23 August 2005

## Materials and methods

### Subjects

Data consulted by our research mainly came from the 2001 National Health Interview Survey in Taiwan, sampling from all the administrative divisions in Taiwan. The cross-sectional data used household as its smallest sampling unit, and all the members of a sampled household received the interview. The response rate was more than 85%.<sup>19</sup> The questionnaires answered by nonaboriginal male respondents aged 20–59 years read 6423. Among them 297 respondents were excluded because of incompleteness of data. Total number of samples analyzed was 6126. Since aborigines occupy less than 2% of the total population and very few nonaboriginal female subjects have betel nut chewing experience (0.2% for ex-chewers and 3.1% for current chewers), they were not included in the analysis.

### Dependent variable

The World Health Organization defines obesity as  $BMI \geq 30 \text{ kg/m}^2$ . This Caucasian standard corresponds approximately to  $\geq 27 \text{ kg/m}^2$  for Taiwanese adults.<sup>1,20</sup> Obesity, as the dependent variable of the research, was accordingly defined by the criterion of  $BMI \geq 27 \text{ kg/m}^2$ .

### Experience of betel nut chewing

The major independent variable of the research was the experience of betel nut chewing, and according to which the subjects were divided into three groups: nonchewers, ex-chewers, and current chewers. The nonchewers (including only once or twice experience) were defined as the reference group.

### Other independent variables

Other independent variables included the respondents' age, educational background, presence of hypertension and diabetes mellitus, drinking and smoking status, exercise status, and demand for physical strength at job. Age and educational background were treated as continuous variables. Educational background referred to the number of years receiving primary and above education. The presence of hypertension was defined as those receiving antihypertensive agents based on the 2000–2001 National Health Insurance outpatient and in-patient records; respondents with no hypertension (blood pressure  $< 140/90 \text{ mmHg}$ ) formed the reference group. The presence of diabetes mellitus was defined as those receiving hypoglycemic agents based on National Health Insurance records; reference group comprised respondents with no diabetes mellitus. Respondents were divided into various groups as follow: four groups of alcohol drinking status: nondrinkers (the reference group), those drinking alcohol less than once a month, those drinking alcohol once to thrice a month, and those

drinking alcohol once a week or more often; four groups of smoking status: nonsmokers (the reference group), ex-smokers, occasional smokers, and regular smokers; and three groups of exercise status: nonexercisers (the reference group), occasional exercisers, and regular exercisers. Regular exercisers referred to those exercising at least six times every 2-weeks, and more than 30 min each time.

Demand for physical strength at job was divided into three different levels in accordance with the respondents' occupations: sedentary, intermediate, and laborious. Sedentary jobs included physicians, lawyers and other highly professional workers, general office workers, retired persons and people between jobs, etc. Intermediate physical strength at jobs incorporated construction and engineering site supervisors, bakers, carpenters, peddlers, technicians, street cleaners, nannies, janitors, waiters or waitresses, students, etc. Laborious jobs included: construction workers, nonclerical career soldiers, farmers, fisherpersons, miners, seafarers, etc.

### Statistical analysis

Since individual respondents might come from the same household, the data are similar in nature and thus there might be a lack of independence among observations. As an alternative approach, the generalized estimating equations (GEE) model, which resembles the general logistic regression model, but takes into account the dependence among observations, was adopted to perform multiple logistic regression analysis and to estimate the odds ratio (with 95% CI) of obesity of each independent variable.

## Results

The average age was  $37.5 \pm 10.8$  years (mean  $\pm$  s.d.), the mean value of BMI was  $23.8 \pm 3.4 \text{ kg/m}^2$ , and the mean educational value was  $11.6 \pm 3.3$  years. Breakdown of respondents by the status of betel nut chewing read 15.9% (current chewers, whose average length of betel nut chewing was 13.4 years), 4.3% (ex-chewers, the average length of chewing 11.3 years), and 79.8% (nonchewers) (Table 1).

As Table 2 indicates, after controlling for the other independent variables, hypertension, diabetes mellitus, betel nut chewing, exercising, and sedentary job were closely associated with obesity.

Respondents who have the habit of betel nut chewing were more likely to be obese than those who never chewed (odds ratio 1.475,  $P < 0.001$ ). Also those who were ex-betel nut chewers tended to be more obese than those who never chewed ( $P = 0.052$ ). The relationship between betel nut chewing and the respondents' daily consumption of rice or noodles (not incorporated into the regression model for control) was further examined by  $\chi^2$ -test. Results revealed that 39.8% of current betel nut chewers took three or more helpings of rice (noodles) per day. The percentage dropped to 36.4% for ex-chewers and decreased further to 32.1% for

Table 1 Characteristics of the study subjects

Variables	Obese (n = 992)	Nonobese (n = 5134)	Total (n = 6126)
Mean age ± s.d. (year)	39.34 ± 10.1	37.17 ± 10.9	37.53 ± 10.8
Mean educational level ± s.d. (year)	11.26 ± 3.3	11.68 ± 3.3	11.61 ± 3.3
Mean BMI ± s.d.	29.34 ± 2.3	22.76 ± 2.4	23.82 ± 3.4
<b>BMI group (%)</b>			
BMI ≥ 27	100.0	0.0	16.2
24 ≤ BMI < 27	0.0	33.4	28.0
BMI < 24	0.0	66.6	55.8
<b>Hypertension (%)</b>			
No	85.2	95.0	93.4
Yes	14.8	5.0	6.6
<b>Diabetes mellitus (%)</b>			
No	92.7	97.0	96.3
Yes	7.3	3.0	3.7
<b>Alcohol drinking</b>			
Never	50.7	54.4	53.8
Less than once per month	11.1	10.9	11.0
Once–thrice per month	11.7	12.7	12.5
More than once per week	26.5	22.0	22.7
<b>Smoking status</b>			
Never	42.3	46.0	45.4
Ex-smokers	7.1	4.5	4.9
Occasional smokers	3.7	3.4	3.4
Regular smokers	46.9	46.2	46.3
<b>Betel nut chewing</b>			
Never	73.9	81.0	79.8
Ex-chewers	5.7	4.0	4.3
Current chewers	20.4	15.0	15.9
<b>Exercise status</b>			
Never	54.9	51.0	51.7
Occasional	24.6	27.3	26.9
Regular	20.5	21.6	21.4
<b>Demand for physical strength at job</b>			
Sedentary	64.9	59.0	59.9
Intermediate	25.7	28.6	28.1
Laborious	9.4	12.5	12.0

nonchewers. The percentage of eating less than two helpings of rice (noodles) was 25.2% for current chewers, 29.6% for ex-chewers, and 31.8% for nonchewers. It is obvious that the daily consumption of rice (noodles) for betel nut chewers was greater than that for nonbetel nut chewers ( $P < 0.001$ ,  $\chi^2$ -test) (Figure 1). However, the association of rice (noodles) consumption and obesity was not proved by  $\chi^2$ -test.

### Discussions

Obesity is a common chronic disease in Taiwan<sup>1</sup> and worldwide.<sup>15,21,22</sup> Our analysis confirmed that betel nut

Table 2 Results of multivariate analysis on factors associated with obesity<sup>a</sup>

	Odds ratio (95%CI)
Age	1.004 (0.997–1.012)
Education background	0.988 (0.963–1.013)
<b>Hypertension</b>	
No (ref.) <sup>b</sup>	
Yes	2.757 (2.169–3.505) <sup>†</sup>
<b>Diabetes mellitus</b>	
No (ref.)	
Yes	1.642 (1.184–2.275) <sup>†</sup>
<b>Alcohol drinking</b>	
Never (ref.)	
Less than once per month <sup>†</sup>	1.108 (0.882–1.393)
Once–thrice per month	0.976 (0.779–1.222)
More than once per week	1.164 (0.963–1.407)
<b>Smoking status</b>	
Never (ref.)	
Ex-smokers	1.314 (0.957–1.804)
Occasional smokers	1.094 (0.753–1.588)
Regular smokers	0.887 (0.745–1.055)
<b>Betel nut chewing</b>	
Never (ref.)	
Ex-chewers	1.384 (0.997–1.921)
Current chewers	1.475 (1.200–1.814) <sup>†</sup>
<b>Exercise status</b>	
Never (ref.)	
Occasional	0.879 (0.739–1.046)
Regular	0.822 (0.680–0.995) <sup>*</sup>
<b>Demand for physical strength at job</b>	
Sedentary (ref.)	
Intermediate	0.864 (0.731–1.021)
Laborious	0.685 (0.537–0.875) <sup>†</sup>

<sup>a</sup>GEE models of risk factors associated with obesity. <sup>b</sup>Ref.: reference group. <sup>\*</sup> $P < 0.05$  <sup>†</sup> $P < 0.01$  <sup>‡</sup> $P < 0.001$ .

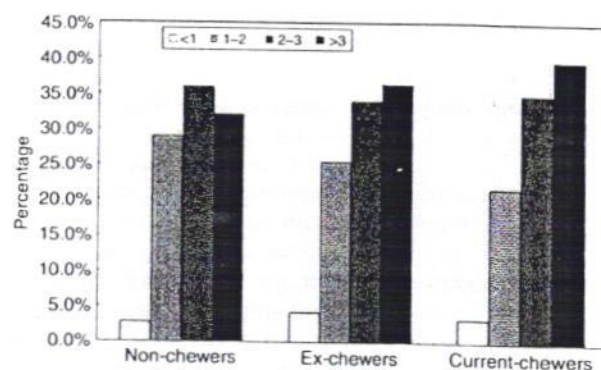

Figure 1 Relationship between betel nut chewing and daily consumption of rice (noodles). Current chewers ate significantly more rice (or noodles) per day than nonchewers with  $P < 0.001$  by  $\chi^2$  test.

chewing was associated with obesity. This result echoed the finding of a research conducted on the people of Bangladeshi ancestry in east London.<sup>10</sup>

To clarify if there is any significant difference between the 297 samples excluded from our analysis because of their data incompleteness (incomplete samples) and the 6126 analyzed samples with complete data (complete samples), the comparison of the two sub-samples was executed. It was found that the incomplete samples were older, had a lower education level, higher prevalence of betel nut chewing, lower regular exercising rate, and a higher rate of laborious jobs than the complete samples. We analyzed two additional models, in which both complete and incomplete samples were included, to adjust the potential bias resulted from the difference between these two sub-samples. In the first model, we assumed conservatively all the 297 incomplete samples were nonobese, and in model 2 we assumed radically that they were all obese. Both models showed similar results and confirmed the finding of our original model (only included the complete samples) that betel nut chewing was significantly associated with obesity (data not shown).

The contribution of betel nut chewing to obesity may lie in the fact that the alkaloid in betel nut can promote one's appetite by inhibiting GABA receptor.<sup>23</sup> Although our analysis showed that betel nut chewers took more staple food than nonchewers did, we did not have data about the intake of calories. The assumption that the obesity of betel nut chewers is related with increased food intake needs further investigation.

In accordance with other reports, our study also found that the presence of hypertension,<sup>24-26</sup> diabetes mellitus,<sup>12,14,17,27,28</sup> lack of exercise,<sup>29,30</sup> and those with sedentary jobs<sup>31</sup> were associated with obesity (Table 2). Respondents who did regular exercise or laborious jobs had significantly lower percentage of being obese, suggesting that more physical activities do help reduce obesity.

In conclusion, betel nut chewing, the presence of hypertension and diabetes mellitus, and sedentary lifestyle are closely associated with obesity. Since obesity might lead to the development of diabetes and hypertension, the association between betel nut chewing and diabetes mellitus, and between betel nut chewing and hypertension is currently under investigation.

**Acknowledgements**

We thank all the task force members at the Bureau of Health Promotion of DOH, and National Health Research Institutes for their generous assistance in providing the National Health Insurance data and the results of the 2001 National Health Interview Survey in Taiwan.

**References**

1 Lin YC, Yen LL, Chen SY, Kao MD, Tzeng MS, Huang PC et al. Prevalence of overweight and obesity and its associated factors: findings from National Nutrition and Health Survey in Taiwan, 1993-1996. *Prev Med* 2003; 37: 233-241.

2 Warnakulasuriya S. Areca nut use following migration and its consequences. *Addict Biol* 2002; 7: 127-132.

3 Boucher BJ, Mannan N. Metabolic effects of the consumption of *Areca catechu*. *Addict Biol* 2002; 7: 103-110.

4 Shieh DH, Chiang LC, Lee CH, Yang YH, Shieh TY. Effects of arecoline, safrole, and nicotine on collagen phagocytosis by human buccal mucosal fibroblasts as a possible mechanism for oral submucous fibrosis in Taiwan. *J Oral Pathol Med* 2004; 33: 581-587.

5 Chen PC, Kuo C, Pan CC, Chou MY. Risk of oral cancer associated with human papillomavirus infection, betel quid chewing, and cigarette smoking in Taiwan - an integrated molecular and epidemiological study of 58 cases. *J Oral Pathol Med* 2002; 31: 317-322.

6 Lee CH, Ko YC, Huang HL, Chao YY, Tsai CC, Shieh TY et al. The precancer risk of betel quid chewing, tobacco use and alcohol consumption in oral leukoplakia and oral submucous fibrosis in southern Taiwan. *Br J Cancer* 2003; 88: 366-372.

7 Yang YH, Lee HY, Tung S, Shieh TY. Epidemiological survey of oral submucous fibrosis and leukoplakia in aborigines of Taiwan. *J Oral Pathol Med* 2001; 30: 213-219.

8 Johnston GA, Krogsgaard-Larsen P, Stephanson A. Betel nut constituents as inhibitors of gamma-aminobutyric acid uptake. *Nature* 1975; 258: 627-628.

9 Strickland SS, Duffield AE. Anthropometric status and resting metabolic rate in users of the areca nut and smokers of tobacco in rural Sarawak. *Ann Hum Biol* 1997; 24: 453-474.

10 Mannan N, Boucher BJ, Evans SJ. Increased waist size and weight in relation to consumption of *Areca catechu* (betel-nut); a risk factor for increased glycaemia in Asians in east London. *Br J Nutr* 2000; 83: 267-275.

11 Sundell J. Obesity and diabetes as risk factors for coronary artery disease: from the epidemiological aspect to the initial vascular mechanisms. *Diabet Obes Metab* 2005; 7: 9-20.

12 Carr MC, Brunzell JD. Abdominal obesity and dyslipidemia in the metabolic syndrome: importance of type 2 diabetes and familial combined hyperlipidemia in coronary artery disease risk. *J Clin Endocrinol Metab* 2004; 89: 2601-2607.

13 Kriska AM, Saremi A, Hanson RL, Bennett PH, Kobes S, Williams DE et al. Physical activity, obesity, and the incidence of type 2 diabetes in a high-risk population. *Am J Epidemiol* 2003; 158: 669-675.

14 Tulloch-Reid MK, Williams DE, Looker HC, Hanson RL, Knowler WC. Do measures of body fat distribution provide information on the risk of type 2 diabetes in addition to measures of general obesity? Comparison of anthropometric predictors of type 2 diabetes in Pima Indians. *Diabet Care* 2003; 26: 2556-2561.

15 Mokdad AH, Ford ES, Bowman BA, Dietz WH, Vinicor F, Bales VS et al. Prevalence of obesity, diabetes, and obesity-related health risk factors, 2001. *JAMA* 2003; 289: 76-79.

16 Pradhan AD, Skerrett PJ, Manson JE. Obesity, diabetes, and coronary risk in women. *J Cardiovasc Risk* 2002; 9: 323-330.

17 Li G, Chen X, Jang Y, Wang J, Xing X, Yang W et al. Obesity, coronary heart disease risk factors and diabetes in Chinese: an approach to the criteria of obesity in the Chinese population. *Obes Rev* 2002; 3: 167-172.

18 Ko YC, Chiang TA, Chang SJ, Hsieh SF. Prevalence of betel quid chewing habit in Taiwan and related sociodemographic factors. *J Oral Pathol Med* 1992; 21: 261-264.

19 Shih YT, Hung YT, Chang HY, Liu JP, Lin HS, Chang MC et al. The design, contents, operation and the characteristics of the respondents of the 2001 National Health Interview Survey in Taiwan. *Taiwan J Public Health* 2003; 22: 419-430. [In Chinese].

20 Department of Health. *National Nutrition Status: Nutrition and Health Survey in Taiwan (NAHSIT) 1993-1996*. DOH: Taipei, 1999.

21 Flegal KM, Carroll MD, Ogden CL, Johnson CL. Prevalence and trends in obesity among US adults, 1999-2000. *JAMA* 2002; 288: 1723-1727.

22 Soriquer F, Rojo-Martinez G, Esteva dAI, Ruiz de Adana MS, Catala M, Merelo MJ et al. Prevalence of obesity in south-east Spain and

1228

- its relation with social and health factors. *Eur J Epidemiol* 2004; 19: 33-40.
- 23 Boucher B. Diabetes in British South Asians: nature, nurture, and culture. *Diabet Med* 1997; 14: 707-708.
  - 24 Adair LS. Dramatic rise in overweight and obesity in adult Filipino women and risk of hypertension. *Obes Res* 2004; 12: 1335-1341.
  - 25 Rahmouni K, Correia ML, Haynes WG, Mark AL. Obesity-associated hypertension: new insights into mechanisms. *Hypertension* 2005; 45: 9-14.
  - 26 Liu L, Ikeda K, Chen M, Yin W, Mizushima S, Miki T *et al*. Obesity, emerging risk in China: trend of increasing prevalence of obesity and its association with hypertension and hypercholesterolaemia among the Chinese. *Clin Exp Pharmacol Physiol* 2004; 31 (Suppl 2): S8-S10.
  - 27 Wannamethee SG, Shaper AG, Walker M. Overweight and obesity and weight change in middle aged men: impact on cardiovascular disease and diabetes. *J Epidemiol Community Health* 2005; 59: 134-139.
  - 28 Mokdad AH, Ford ES, Bowman BA, Dietz WH, Vinicor F, Bales VS *et al*. Prevalence of obesity, diabetes, and obesity-related health risk factors, 2001. *JAMA* 2003; 289: 76-79.
  - 29 Keim NL, Blanton CA, Kretsch MJ. America's obesity epidemic: measuring physical activity to promote an active lifestyle. *J Am Diet Assoc* 2004; 104: 1398-1409.
  - 30 Davis AL. Fighting obesity: physical activity has major role. *BMJ* 2004; 329: 53.
  - 31 Perbellini L. Job as a risk factor for obesity... and the contrary. *Med Lav* 2004; 95: 211-222.

Published in final edited form as:

*Obesity (Silver Spring)*. 2009 June ; 17(6): 1247–1254. doi:10.1038/oby.2009.38.

## Betel Nut Chewing Is Strongly Associated With General and Central Obesity in Chinese Male Middle-aged Adults

Wen-Yuan Lin, F. Xavier Pi-Sunyer, Chiu-Shong Liu, Tsai-Chung Li, Chia-Ing Li, Chih-Yang Huang, and Cheng-Chieh Lin

### Abstract

Betel nut chewing has been reported to increase the risk of cardiovascular disease and all-cause mortality. The reason is unclear. In this study, we investigated the association between betel nut chewing and general obesity (BMI  $\geq 25\text{kg/m}^2$ ) and central obesity (waist circumference (WC)  $\geq 90$  cm). A total of 1,049 male subjects, aged  $\geq 40$  years, were recruited from Taichung city in Taiwan in 2004. The relationships between betel nut chewing and general and central obesity were studied by multiple linear and logistic regression analyses. The prevalence of current and former betel nut chewing was 7.0 and 10.5% in our male Taiwanese cohort. Current/former betel nut chewers had a higher prevalence of general and central obesity when compared with individuals who had never chewed betel nut. Adjusted for age, diabetes, hypertension, lipids, smoking, alcohol drinking, physical activity, income, and education level, the odds ratios (ORs; 95% confidence intervals) of general and central obesity among the lower consumption of betel nut chewers were 1.78 (1.07, 2.96) and 1.19 (0.70, 2.02), respectively, compared to 2.01 (1.18, 3.41) and 1.89 (1.10, 3.23), respectively, among higher consumption chewers compared to individuals who had never chewed betel nut. The increasing ORs of general and central obesity with higher betel nut consumption revealed dose-response effects. Using multiple linear regression analyses, after adjusting for potential confounders, betel nut consumption was statistically significantly associated with BMI and WC. In conclusion, betel nut chewing was independently associated with general and central obesity in Taiwanese men. Dose-response effects of the association between betel nut consumption and general obesity as well as central obesity were found.

### INTRODUCTION

Obesity is one of the most serious problems in human health and is recognized as an important risk factor for many chronic diseases, such as cardiovascular disease, type 2 diabetes, hypertension, and cancer (1–6). It has also been identified as the second preventable cause of death (7). Obesity has increased dramatically around the world. In US adults, the prevalence of obesity (BMI  $\geq 30\text{kg/m}^2$ ) doubled between 1986 and 2000 (8). According to the National Bureau of Economic Research in the United States, about three-fourths of Americans  $\geq 20$  years are predicted to be overweight and two-fifths to be obese by the year 2020 (9). Although the prevalence of obesity is high and rising in developed countries, the increase is often faster in developing nations. For example, a nationally representative survey in China from 1991 to 1999–2000 showed that the prevalence of overweight and obesity had dramatically increased in all age groups and in both rural and urban areas (10). The increase of obesity (BMI  $\geq 28\text{kg/m}^2$ ) was more than threefold in men and twofold in women (10). The situation is similar in many other Asia-Pacific regions. In Taiwan, based on the data of the Nutrition and Health Surveys of 1993–1996 and 2000–2001, the prevalence of obesity (BMI  $\geq 25\text{kg/m}^2$ ) in adult

### DISCLOSURE

The authors declared no conflict of interest

men increased from 24.7 to 33.1% (11). This dramatic increase in obesity during the past two decades underscores that every region has its own specific preferences of food and lifestyle behavior and it is important to identify different risk factors leading to obesity in different regions.

Betel nut (*Areca catechu*) is the fourth most widely used addictive substance in the world (12,13). There are ~600 million people who chew betel nut worldwide, most of them resident in Asia-Pacific regions (13). Betel nut chewing is not only related to the development of oral and esophageal cancer (12,14,15) but also to type 2 diabetes mellitus, hypertension, metabolic syndrome, chronic kidney disease, and heart disease (16–20). In a previous study, we found that Taiwanese men who were betel nut chewers (either current chewers or former chewers) had an increased risk of cardiovascular disease and all-cause mortality (21). The main component of betel nut (areca alkaloids) is an inhibitor of  $\gamma$ -aminobutyric acid (GABA) receptor (11). Betel nut chewing was closely associated with BMI and it was proposed that the underlying cause was increased appetite of betel nut chewers through the inhibitory effects of betel nut on the GABA receptor (22). Chang *et al.* and Mannan *et al.* also proposed that obesity could be the possible intermediary by which betel nut chewing could increase cardiovascular disease (22,23). However, these studies only focused on the relationship between betel nut chewing and either general or central obesity. Furthermore, these studies did not detail the cumulative betel nut chewing-years, so that the association between betel nut chewing and obesity could be influenced by residual confounding. Because betel nut consumption may increase the risk for obesity and its complications, it is important to assess the association between betel nut chewing and obesity in Asian countries. The World Health Organization has used BMI and waist circumference (WC) to predict obesity (6), so we investigated the association between both general obesity (measured by BMI) and central obesity (measured by WC) and cumulative betel nut chewing-years in Taiwanese men in a metropolitan city.

## METHODS AND PROCEDURES

### Subjects

The target population was Taiwan citizens aged  $\geq 40$  in Taichung city, Taiwan in October 2004. There were a total of 363,543 residents in this area at this time, which represented ~4.09% of the national population of the same age. A stratified, two-stage random sampling approach was used for the selection of the survey sample; and the sampling rate was proportional to size within each stage. A total of 4,280 individuals were selected. During household visits, we identified 750 individuals who were not eligible and we excluded them from the sample. The reasons for exclusion included death ( $n = 18$ ), hospitalization or imprisonment ( $n = 14$ ), living abroad ( $n = 39$ ), moving out of the home ( $n = 411$ ), living with relatives/children's house ( $n = 7$ ), sampling frame errors ( $n = 59$ ), and not being at home during three visits made by interviewers ( $n = 202$ ). Among 3,530 individuals selected, only 2,359 agreed to participate. Thus, the overall response rate was 66.8% (24–26). Among the 1,147 male subjects, 98 individuals did not complete the questionnaire items pertaining to betel nut chewing habits. Therefore, the baseline subjects analyzed in the study comprised 1,049 male participants. Female betel nut chewers were excluded because the prevalence of chewers in women was very low (prevalence was 17.4% in men and 0.25% in female in this study). No statistical differences were observed in age, height, weight, BMI, WC, and hip circumference among selected subjects ( $n = 1,049$ ) and excluded subjects ( $n = 98$ ).

### Anthropometric index and laboratory assays

Trained staff measured height, WC, hip circumference, weight, and blood pressure as described in previous reports (24–26). The cohort was divided into BMI ( $\text{kg}/\text{m}^2$ ) quartiles. Blood was drawn in the morning after a 12-h overnight fast and was sent for analysis within 4h of

collection. Total cholesterol, high-density lipoprotein cholesterol, triglycerides, and fasting glucose level were analyzed by a biochemical autoanalyzer (Beckman Coulter, Fullerton, CA) at the Clinical Laboratory Department (China Medical University Hospital, Taichung, Taiwan).

### Sociodemographic factors and lifestyle behaviors

Information on selected demographic (age, gender, marital status, employment, level of education), socioeconomic, lifestyle, and behavioral characteristics (diet history, physical activity) including medical history were collected using self-administered questionnaires. Marital status was coded as single (unmarried), married, and widower/divorce/separate. The cumulative exposure to smoking, alcohol drinking, and betel nut chewing was assessed by recording the duration (years), frequency (times/day), quantity (number/times), and ethanol content (percent). Former users were also asked for their age at quitting. Cumulative pack-years of smoking were calculated as smoking-years multiplied by average daily cigarette use divided by 20. Cumulative pack-years for smokers were categorized based on an equal distribution (low:  $\leq 19.5$  pack-years; high:  $> 19.5$  pack-years), so smoking status was categorized as none (0 pack-years), low (0–19.5 pack-years), and high ( $> 19.5$  pack-years). History of alcohol consumption was coded as drink-years (drink/day  $\times$  years) in which a “drink” was defined as consuming 0.5 oz (13.7g) of ethanol (27). Average alcohol consumption for each time was defined as the average amount of alcohol consumed each time across the interviews. The average frequency of alcohol drinking was recorded as limes/week. It was divided by 7 to get times/day. The average content of alcohol drinking was recorded as the average percent of different type of alcohol which subjects usually drink. Daily alcohol amount for a consumed beverage was calculated as follows: “drink” = average alcohol consumption per times  $\times$  average frequency per day  $\times$  average content of alcohol drinking divided by 13.7. Drink-years for alcohol drinkers were categorized based on an equal distribution (low:  $\leq 3.4$  drink-year; high:  $> 3.4$  drink-years), so alcohol drinking status was divided as none, low, and high.

Average betel nut chewing was defined as the average amount of betel nut consumed each time across the interviews (quids/times). The average frequency of betel nut chewing was recorded as times/day. Cumulative quids/day-years of betel nut chewing was calculated as follows: betel nut consumed each time  $\times$  daily average frequency of betel nut chewing  $\times$  exposure years. Betel nut chewing-years for chewers were categorized based on an equal distribution (low:  $\leq 76$  quids/day  $\times$  year; high:  $> 76$  quids/day  $\times$  year). Finally, betel nut chewing status was divided as none, low, and high. Income was divided into three levels: low ( $< \text{USD } 15,000/\text{year}$ , rate = 32:1), middle (15,000–37,500/year), and high ( $> 37,500/\text{year}$ ). Education was also divided into three levels: low (elementary school and below), middle (junior and senior high school), and high (college/university and above).

### Definitions of obesity, diabetes, hypertension, and mean arterial pressure

Obesity was defined as BMI  $\geq 25 \text{ kg/m}^2$  and central obesity as WC  $\geq 90 \text{ cm}$ , according to the definition of the World Health Organization for Asia-Pacific area (5). Diabetes was defined as fasting plasma glucose concentration  $\geq 7.0 \text{ mmol/l}$  or on drug treatment for diabetes. Hypertension was defined as systolic BP  $\geq 140 \text{ mm Hg}$  or diastolic BP  $\geq 90 \text{ mm Hg}$  or on drug treatment for hypertension. Mean arterial pressure was calculated as  $((2 \times \text{diastolic BP}) + \text{systolic BP})/3$ .

### Statistical analysis

The data are presented as means and s.d. unless indicated otherwise. Student's *t*-test and Pearson's  $\chi^2$ -test were used to compare mean values for continuous and categorical variables. Log transformation was used for variables with significant deviation from normal distribution,

assessed by the Kolmogorov–Smirnov test before further analyses. ANOVA test was used to compare the continuous variables across betel nut chewing groups. The Pearson's  $\chi^2$ -test was used to compare the differences in the lifestyle variables (smoking, alcohol drinking, betel nut chewing, and physical activity) and socioeconomic factors (income and education level). Multivariate logistic regression analyses were used to estimate the adjusted odds ratios (ORs) and their 95% confidence intervals for the presence of general and central obesity in relation to betel nut chewing. Three different models were derived by adjusting for different confounders (such as age, lifestyle behavior, and laboratory assays) to minimize residual confounding. Multiple linear regression analyses were also used to assess the association between BMI/WC and cumulative exposure of betel nut chewing with adjustment for potential confounders. All statistical tests were two sided at the 0.05 significance level. These statistical analyses were performed using the PC version of SPSS statistical software (13th version; SPSS, Chicago, IL).

Ethics approval for patient recruitment and data analyses was obtained from the Institutional Review Board of the China Medical University Hospital.

## RESULTS

The prevalence of current and former betel nut chewing was 7.0 and 10.5% in male Taiwanese. The prevalence of general and central obesity was 43.5 and 33.9%, respectively. Subjects with general obesity were younger and had higher body weight, BMI, WC, hip circumference, systolic BP, diastolic BP, fasting glucose, triacylglycerol, and prevalence of hypertension and lower high-density lipoprotein cholesterol than nongeneral obesity subjects (Table 1). Central obesity subjects were older and had greater height, body weight, BMI, WC, hip circumference, systolic BP, diastolic BP, triacylglycerol, and the prevalence of diabetes and hypertension and lower high-density lipoprotein cholesterol than noncentral obesity subjects (Table 1). Chewers with higher betel nut consumption were younger and had higher body weight, BMI, WC, smoking pack-years, alcohol drink-years, triacylglycerol, income level, and education level than nonchewers (Table 2). Using multiple logistic regression analyses with adjustment for potential confounders, the ORs for general and central obesity were statistically higher among chewers with higher betel nut consumption than among nonchewers (models 1–3 in Table 3). Among these models, there was no interaction ( $P > 0.05$ ) between betel nut chewing and smoking or alcohol drinking status for predicting the risk of general and central obesity. Adjusting for age, diabetes, hypertension, lipids, smoking, alcohol drinking, physical activity, income, and education level, the adjusted ORs (95% confidence intervals) of general and central obesity among the lower consumption of betel nut chewers were 1.78 (1.07, 2.96) and 1.19 (0.70, 2.02), respectively, and 2.01 (1.18, 3.41) and 1.89 (1.10, 3.23), respectively, among higher consumption chewers compared with individuals who had never chewed betel quid (model 3 in Table 3). To better understand the association between obesity and cumulative betel nut chewing exposure, we also used multiple linear regression analyses to clarify the relationship between BMI and/or WC and betel nut chewing-years (Table 4). Log transformation for mean arterial pressure, fasting glucose, and triacylglycerol were done for normal distribution. The distribution about cumulative betel nut chewing, smoking, and alcohol drinking was not normal, so we divided them into two dummy variables (high vs. none and low vs. none). After adjusting for potential confounders, we found that BMI and WC were strongly associated with cumulative betel nut exposure (betel nut chewing-years) (Table 4). Smoking is another risk factor of general and central obesity. To further clarify the effect of smoking and betel nut chewing on obesity, we analyzed the relationship between betel nut chewing and general and/or central obesity in never smokers. Figure 1 compares those who never smoked to never chewers. Using multiple logistic regression analyses with adjustment for potential confounders, the adjusted ORs of general obesity (Figure 1a) and central obesity (Figure 1b) among the lower consumption of betel nut chewers were 3.64 (0.71, 18.6) and 1.57

(0.40, 6.22), respectively, and 2.97 (0.50, 17.9) and 6.32 (1.00, 39.7), respectively, among higher consumption chewers. The adjusted ORs for the presence of general and central obesity in relation to betel nut chewing were higher among never smokers than among all subjects (Figure 1).

## DISCUSSION

We have demonstrated that both general obesity and central obesity are closely associated to cumulative betel nut chewing-years in a population-based study. Dose-response effects were also found. Furthermore, the effects of betel nut chewing on obesity are remarkably increased in never smokers. Our finding has important implications because there is a large population in the world who is obese and chews betel nuts. A great challenge in public health in Taiwan, as well as in other countries with a high prevalence of betel nut chewing, is to develop useful strategies for the cessation of betel nut chewing.

Few studies have addressed the association between obesity and betel nut chewing. Previous animal studies have shown inconsistent results. For example, 2-week-old hamsters which were fed betel quid or areca nut for 18 months showed decreased body weight (28). On the contrary, young adult CD1 mice which were fed betel nut in standard feed for 2–6 days developed central obesity later (29). Two epidemiological human studies support our result. In one, Yen *et al.* found betel-quid chewing to be associated with central obesity in a population-based study (16). In another, Mannan *et al.* found that Asian betel nut chewers in East London increased their WC (23). Chang *et al.* also found betel nut chewing associated with general obesity in Taiwan (22). However, there are no population-based studies which investigated the relationship between betel nut chewing and both general and central obesity. Our population-based study demonstrates that both general and central obesity (using either multiple logistic regression or multiple linear regression analyses) are strongly associated with betel nut chewing. Although our study is a cross-sectional one, our population is large enough to allow us to adjust for many potential confounders, such as lifestyle factors, diabetes, hypertension, and lipid profile, which have been shown to increase the risk of obesity. Finally, we also have found the adjusted ORs for general and central obesity increased with the increase of cumulative betel nut chewing-years dose, which supports the possibility of a causal association between betel nut chewing and obesity. The dose-response relationship exists numerically, but did not reach statistical significance between the high and low doses of betel nut chewing.

There are two possible mechanisms linking obesity and betel nut chewing. First, the main component of betel nut (areca alkaloids) is an inhibitor of GABA receptor (12). The inhibitory effects of betel nut on the GABA receptor may result in an increase of appetite with eventual fat accumulation (12). Second, the areca nitrosamines derived from areca alkaloids are diabetogenic (12,29). Tung *et al.* have found that betel nut chewing independently contributes to the risk of hyperglycemia and type 2 diabetes in Taiwanese men (19). Hyperglycemia and type 2 diabetes are closely related to insulin resistance. Betel nut chewing may induce the development of insulin resistance, which is associated with an increase in obesity over time (30). The exact mechanism linking betel nut and obesity is unknown and this merits further study.

Cigarette smokers tend to have a lower BMI than nonsmokers (31). However, cigarette smokers accumulate significantly more abdominal adiposity than nonsmokers of a similar BMI (32–34). Although quitting smoking leads to weight gain, less upperbody fat deposition occurs than would be expected (34). In our study, we found that subjects with central obesity had a higher percent of current/former smokers than subjects with noncentral obesity, but this was not true for the general obesity group (Table 1). In Table 4, even though there was no statistically significant difference between BMI/WC and smoking status, the relationship between WC and

smoking status trends positive and for BMI, it trends negative. This is similar to other studies (32,33). Both betel nut chewing and smoking are independently associated with central obesity in this study. We also analyzed the effect of betel nut chewing and smoking on obesity. In Figure 1, we found that the adjusted ORs are higher in never smokers than in all subjects. It seems that betel nut chewing is more important than smoking on increasing obesity, especially in central obesity. Furthermore, the adjusted ORs for central obesity increased with an increase of cumulative betel nut chewing dose, revealing a dose-response effect. Developing useful strategies for the cessation of both smoking and betel nut chewing are important future initiatives to prevent central obesity. In our previous report, we found that 83 and 64% of current betel nut chewers are concurrent smokers and alcohol drinkers, respectively (21). From Table 2, we found that subjects with a higher cumulative exposure of betel nut chewing tended to have a higher cumulative exposure of smoking and alcohol. It is likely that successful smoking cessation will reduce the rate of betel nut chewing in areas with a high prevalence of both smoking and betel nut chewing.

Smoking rate is increasing in most developing countries, especially in China, India, and Indonesia which also have a high prevalence of betel nut chewing (35). Successful smoking cessation strategies have been developed in the United States. According to the Centers for Disease Control and Prevention, cigarette smoking has been dropping steadily among American adults from 42.4% in 1965 to 28.8% in 1987, and 19.8% in 2007 (36). Applying similar smoking cessation strategies developed in United States on betel nut cessation may result in dramatically lowering the prevalence of cigarette smoking and betel nut chewing in Asia-Pacific countries.

We also found that physical inactivity, low income level, and low education level were associated with cumulative betel nut chewing in this population-based study. This is similar to previous studies (16,21).

Although we have shown that betel nut chewing is closely related to obesity, there are several limitations to this study. First, this study is a cross-sectional one, so causality cannot be demonstrated. Future prospective cohort studies are necessary. Second, the exposure to betel nut chewing was from self-report questionnaires, the potential misclassification of the exposure is possible which would probably have biased the result toward the null. However, using the cumulative exposure of betel nut chewing to assess the relationship to obesity can minimize the residual confounding. Furthermore, we show dose-response effects between betel nut chewing and obesity. Thus, it is impossible to cause a biased result but the true strength of association may be weakened.

In conclusion, we have demonstrated that betel nut chewing is closely associated with general and central obesity. Increasing cumulative doses of betel nut chewing relate to general and central obesity, revealing a dose-response effect. As the prevalence of obesity has increased dramatically worldwide in the past decades, it is important to identify different risk factors in varied regions, so useful local strategies can be developed. In this study, we have identified that betel nut chewing is a risk factor for obesity. Useful strategies for betel nut chewing cessation should be initiated to prevent further increases in chronic diseases which may be caused by obesity.

## Acknowledgments

This study is supported by grants from National Science Council of Taiwan (NSC 93-2314-B-039-025, NSC 94-2314-B-039-024) and from US National Institutes of Health (DK 026687). We thank all the staffs who helped the data collection in China Medical University.

## References

1. Ko GT, Tang JS. Waist circumference and BMI cut-off based on 10-year cardiovascular risk: evidence for "central pre-obesity". *Obesity (Silver Spring)* 2007;15:2832–2839. [PubMed: 18070775]
2. Krishnan S, Rosenberg L, Djousse L, Cupples LA, Palmer JR. Overall and central obesity and risk of type 2 diabetes in U.S. black women. *Obesity (Silver Spring)* 2007;15:1860–1866. [PubMed: 17636105]
3. Reeves GK, Pirie K, Beral V, et al. Cancer incidence and mortality in relation to body mass index in the Million Women Study: cohort study. *BMJ* 2007;335:1134. [PubMed: 17986716]
4. Renehan AG, Tyson M, Egger M, Heller RF, Zwahlen M. Body-mass index and incidence of cancer: a systematic review and meta-analysis of prospective observational studies. *Lancet* 2008;371:569–578. [PubMed: 18280327]
5. World Health Organization, International Association for the Study of Obesity and International Obesity Task Force. The Asia-Pacific perspective: redefining obesity and its treatment. Health Communications; Sydney: 2000 [Accessed 14 January 2009]. <<http://www.iaotf.org/asiapacific/>>
6. World Health Organization. Obesity: preventing and managing the global epidemic. Report of a WHO consultation. World Health Organ. Tech Rep Ser 2000;894:1–253.
7. Flegal KM, Williamson DF, Pamuk ER, Rosenberg HM. Estimating deaths attributable to obesity in the United States. *Am J Public Health* 2004;94:1486–1489. [PubMed: 15333299]
8. Sturm R. Increases in clinically severe obesity in the United States, 1986–2000. *Arch Intern Med* 2003;163:2146–2148. [PubMed: 14557211]
9. Ruhm, CJ. Current and Future Prevalence of Obesity and Severe Obesity in the United States. National Bureau of Economic Research; Cambridge, MA: 2007.
10. Wildman RP, Gu D, Muntner P, et al. Trends in overweight and obesity in Chinese adults: between 1991 and 1999–2000. *Obesity (Silver Spring)* 2008;16:1448–1453. [PubMed: 18388899]
11. Chu NF. Prevalence of obesity in Taiwan. *Obes Rev* 2005;6:271–274. [PubMed: 16246212]
12. Boucher BJ, Mannan N. Metabolic effects of the consumption of *Areca catechu*. *Addict Biol* 2002;7:103–110. [PubMed: 11900629]
13. Gupta PC, Warnakulasuriya S. Global epidemiology of areca nut usage. *Addict Biol* 2002;7:77–83. [PubMed: 11900626]
14. Zhang X, Reichart PA. A review of betel quid chewing, oral cancer and precancer in Mainland China. *Oral Oncol* 2007;43:424–430. [PubMed: 17258497]
15. Wu JC, Lu CY, Kuo FC, et al. Interaction between cigarette, alcohol and betel nut use on esophageal cancer risk in Taiwan. *Eur J Clin Invest* 2006;36:236–241. [PubMed: 16620285]
16. Yen AM, Chiu YH, Chen LS, et al. A population-based study of the association between betel-quid chewing and the metabolic syndrome in men. *Am J Clin Nutr* 2006;83:1153–1160. [PubMed: 16685060]
17. Guh JY, Chen HC, Tsal JF, Chung LY. Betel-quid use is associated with heart disease in women. *Am J Clin Nutr* 2007;85:1229–1235. [PubMed: 17490957]
18. Guh JY, Chuang LY, Chen HC. Betel-quid use is associated wrth the risk of the metabolic syndrome in adults. *Am J Clin Nutr* 2006;83:1313–1320. [PubMed: 16762942]
19. Tung TH, Chiu YH, Chen LS, et al. A population-based study of the association between areca nut chewing and type 2 diabetes mellitus in men (Keelung Community-based Integrated Screening programme No. 2). *Diabetologia* 2004;47:1776–1781. [PubMed: 15517150]
20. Kang IM, Chou CY, Tseng YH, et al. Association between betelnut chewing and chronic kidney disease in adults. *J Occup Environ Med* 2007;49:776–779. [PubMed: 17622851]
21. Lin WY, Chiu TY, Lee LT, et al. Betel nut chewing is associated with increased risk of cardiovascular disease and all-cause mortality in Taiwanese men. *Am J Clin Nutr* 2008;87:1204–1211. [PubMed: 18469240]
22. Chang WC, Hsiao CF, Chang HY, et al. Betel nut chewing and other risk factors associated with obesity among Taiwanese male adults. *Int J Obes (Lond)* 2006;30:359–363. [PubMed: 16116491]

23. Mannan N, Boucher BJ, Evans SJ. Increased waist size and weight in relation to consumption of *Areca catechu* (betel-nut); a risk factor for increased glycaemia in Asians in east London. *Br J Nutr* 2000;83:267-275. [PubMed: 10884715]
24. Lin CC, Liu CS, Li TC, et al. Microalbuminuria and the metabolic syndrome and its components in the Chinese population. *Eur J Clin Invest* 2007;37:783-790. [PubMed: 17888089]
25. Lin CC, Liu CS, Lal MM, et al. Metabolic syndrome in a Taiwanese metropolitan adult population. *BMC Public Health* 2007;7:239. [PubMed: 17850675]
26. Chang, PC.; Li, TC.; Wu, MT., et al. Association between television viewing and the risk of metabolic syndrome in a community-based population. *BMC Public Health*;
27. Lichtenstein AH, Appel LJ, Brands M, et al. Diet and lifestyle recommendations revision 2006: a scientific statement from the American Heart Association Nutrition Committee. *Circulation* 2006;114:82-96. [PubMed: 16785338]
28. Chiang CP, Chang MC, Lee JJ, et al. Hamsters chewing betel quid or areca nut directly show a decrease in body weight and survival rates with concomitant epithelial hyperplasia of cheek pouch. *Oral Oncol* 2004;40:720-727. [PubMed: 15172642]
29. Boucher BJ, Ewen SW, Stowers JM. Betel nut (*Areca catechu*) consumption and the induction of glucose intolerance in adult CD1 mice and in their F1 and F2 offspring. *Diabetologia* 1994;37:49-55. [PubMed: 8150230]
30. Gould AJ, Williams DE, Byrne CD, Hales CN, Wareham NJ. Prospective cohort study of the relationship of markers of insulin resistance and secretion with weight gain and changes in regional adiposity. *Int J Obes Relat Metab Disord* 1999;23:1256-1261. [PubMed: 10643681]
31. Pisinger C, Jorgensen T. Weight concerns and smoking in a general population: the Inter99 study. *Prev Med* 2007;44:283-289. [PubMed: 17222451]
32. Canoy D, Wareham N, Luben R, et al. Cigarette smoking and fat distribution in 21, 828 British men and women: a population-based study. *Obes Res* 2005;13:1466-1475. [PubMed: 16129730]
33. Shimokata H, Muller DC, Andres R. Studies in the distribution of body fat. III. Effects of cigarette smoking. *JAMA* 1989;261:1169-1173. [PubMed: 2915440]
34. Lissner L, Bengtsson C, Lapidus L, Bjorkelund C. Smoking initiation and cessation in relation to body fat distribution based on data from a study of Swedish women. *Am J Public Health* 1992;82:273-275. [PubMed: 1739163]
35. World Health Organization. WHO report on the global tobacco epidemic, 2008- The MPOWER package. WHO; Geneva: 2008 [Accessed 14 January 2009]. The global tobacco crisis; p. 14-22. <[http://www.who.int/tobacco/mpower/mpower\\_report\\_full\\_2008.pdf](http://www.who.int/tobacco/mpower/mpower_report_full_2008.pdf)>
36. Centers for Disease Control and Prevention. Slightly lower adult smoking rates. CDC; Atlanta, GA: 2008 [Accessed 14 January 2009]. <<http://www.cdc.gov/media/pressref/2008/r081113.htm>>

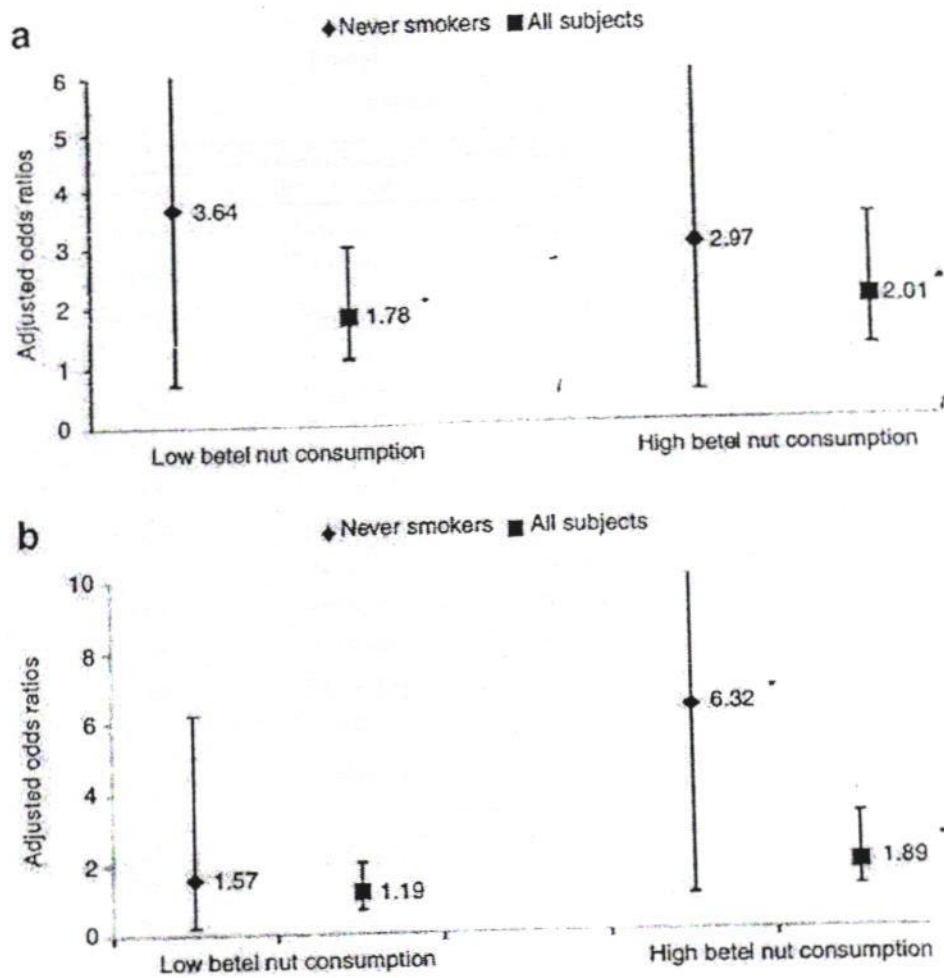

**Figure 1.** Odds ratios between obesity and betel nut chewing in all subjects and never smokers. Adjusted odds ratios of having (a) general obesity and (b) central obesity in all subjects and never smokers derived from a multiple logistic regression analysis using age, diabetes, hypertension, lipid profile, alcohol drinking, physical activity, income, and educational level as independent variables. In never smokers, compared to never chewers, the adjusted odds ratios of general and central obesity among the lower consumption of betel nut chewers were 3.64 (0.71, 18.6) and 1.57 (0.40, 6.22), respectively, and 2.97 (0.50, 17.9) and 6.32 (1.00, 39.7), respectively, among higher consumption chewers. \* $P < 0.05$ .

1238

Table 1

Baseline characteristics according to status of obesity

	General obesity (BMI $\geq 25$ kg/m <sup>2</sup> ) (n = 456)	Nonobesity (BMI <25 kg/m <sup>2</sup> ) (n = 593)	Centrally obese (WC $\geq 90$ cm) (n = 356)	Noncentrally obese (WC <90cm) (n = 693)
Age (years)	57.3 ± 11.8 <sup>f</sup>	59.6 ± 12.4 <sup>f</sup>	59.8 ± 12.4 <sup>*</sup>	58.1 ± 12.1 <sup>*</sup>
Height (cm)	166.8 ± 6.2	166.2 ± 6.1	167.8 ± 6.3 <sup>f</sup>	165.8 ± 6.0 <sup>f</sup>
Body weight (kg)	76.9 ± 8.7 <sup>f</sup>	62.6 ± 6.7 <sup>f</sup>	78.0 ± 9.3 <sup>f</sup>	64.2 ± 7.4 <sup>f</sup>
BMI (kg/m <sup>2</sup> )	27.6 ± 2.3 <sup>f</sup>	22.7 ± 1.8 <sup>f</sup>	27.7 ± 2.7 <sup>f</sup>	23.3 ± 2.3 <sup>f</sup>
WC (cm)	92.9 ± 7.0 <sup>f</sup>	81.3 ± 6.5 <sup>f</sup>	95.8 ± 5.6 <sup>f</sup>	81.5 ± 5.8 <sup>f</sup>
HipC (cm)	101.5 ± 5.9 <sup>f</sup>	93.5 ± 4.6 <sup>f</sup>	102.6 ± 5.6 <sup>f</sup>	94.0 ± 4.8 <sup>f</sup>
Systolic BP (mmHg)	143.0 ± 20.3 <sup>f</sup>	134.4 ± 20.1 <sup>f</sup>	145.8 ± 20.5 <sup>f</sup>	134.2 ± 19.5 <sup>f</sup>
Diastolic BP (mmHg)	85.6 ± 11.3 <sup>f</sup>	80.0 ± 11.2 <sup>f</sup>	86.5 ± 11.1 <sup>f</sup>	80.3 ± 11.2 <sup>f</sup>
Fasting glucose (mmol/l)	6.00 ± 1.49 <sup>*</sup>	5.79 ± 1.65 <sup>*</sup>	6.14 ± 1.65 <sup>f</sup>	5.74 ± 1.53 <sup>f</sup>
TCHOL (mmol/l)	5.20 ± 0.93	5.14 ± 0.96	5.23 ± 0.96	5.13 ± 0.93
Triacylglycerol (mmol/l)	1.80 ± 1.39 <sup>f</sup>	1.36 ± 1.19 <sup>f</sup>	1.85 ± 1.41 <sup>f</sup>	1.41 ± 1.21 <sup>f</sup>
HDL-C (mmol/l)	1.01 ± 0.25 <sup>f</sup>	1.12 ± 0.30 <sup>f</sup>	1.00 ± 0.24 <sup>f</sup>	1.11 ± 0.30 <sup>f</sup>
Diabetes (%)	15.4	13.0	19.1 <sup>f</sup>	11.4 <sup>f</sup>
Hypertension (%)	64.5 <sup>f</sup>	43.3 <sup>f</sup>	70.2 <sup>f</sup>	43.4 <sup>f</sup>
Alcohol drinking (%)				
Never	52.4	55.6	52.8	55.0
Former	9.6	8.3	10.4	8.1
Current	37.9	36.1	36.8	36.9
Smoking (%)				
Never	45.8	52.1	42.7	52.8
Former	26.1	20.4	27.0	20.8
Current	28.1	27.5	30.3	26.4
Betel nut chewing (%)				
Never	77.9	86.2	79.2	84.3
Former	14.0	7.8	13.8	8.8
Current	8.1	6.1	7.0	6.9
Physical activity (%)				
None/seldom	32.2	29.2	30.3	30.6
Regular	67.8	70.8	69.7	69.4
Income (%)				
Low	44.5	50.6	46.9	48.5
Middle	41.9	39.0	40.9	39.9
High	13.6	10.4	12.3	11.5
Education (%)				
Low	19.6	16.8	20.6	16.6
Middle	38.2	40.1	38.3	39.8
High	42.2	43.1	41.1	43.6

	General obesity (BMI ≥25 kg/m <sup>2</sup> ) (n = 456)	Nonobesity (BMI <25 kg/m <sup>2</sup> ) (n = 593)	Centrally obese (WC ≥90cm) (n = 356)	Noncentrally obese (WC <90cm) (n = 693)
Marital status (%)				
Single (unmarried)	1.8	2.5	1.4	2.6
Married	89.9	87.1	90.7	87.1
Widower/divorce/separate	8.3	10.3	7.9	10.3

Student's *t*-test was used for comparing mean values of continuous variables between groups (general obesity vs. nonobesity group and centrally obese vs. noncentrally obese group), data were shown as means ± s. d. Pearson's  $\chi^2$ -test was used for categorical data; data were shown as percentage.

BP, blood pressure; HDL-C, high-density lipoprotein cholesterol; HipC, hip circumference; TCHOL, total cholesterol; WC, waist circumference.

\*  $P < 0.05$ ;

†  $P < 0.01$ ;

‡  $P < 0.001$ .

**Table 2**  
Demographic and laboratory characteristics according to different categories of betel nut use

	None (n = 866)	Low ( $\leq 76$ quids/day $\times$ year; n = 91)	High ( $> 76$ quids/day $\times$ year; n = 92)	P value
Age (years)	59.6 $\pm$ 12.4	51.9 $\pm$ 9.2	56.5 $\pm$ 10.8	<0.001
Height (cm)	166.6 $\pm$ 6.2	166.5 $\pm$ 5.7	165.3 $\pm$ 5.8	0.179
Body weight (kg)	68.4 $\pm$ 10.4	71.1 $\pm$ 9.7	70.8 $\pm$ 11.0	0.012
BMI (kg/m <sup>2</sup> )	24.6 $\pm$ 3.2	25.6 $\pm$ 2.9	25.8 $\pm$ 3.4	<0.001
WC(cm)	86.1 $\pm$ 8.8	85.9 $\pm$ 7.9	89.5 $\pm$ 9.4	0.001
HipC(cm)	96.9 $\pm$ 6.5	96.8 $\pm$ 6.9	97.7 $\pm$ 6.7	0.502
Smoking (pack-years)	9.31 $\pm$ 16.6	21.4 $\pm$ 17.9	27.2 $\pm$ 20.5	<0.001
Alcohol (drink-years)	8.79 $\pm$ 39.2	25.7 $\pm$ 123.5	32.1 $\pm$ 71.5	<0.001
Systolic BP (mm Hg)	138.3 $\pm$ 20.3	134.0 $\pm$ 19.6	140.5 $\pm$ 23.7	0.085
Diastolic BP (mm Hg)	82.1 $\pm$ 11.3	82.9 $\pm$ 12.3	84.9 $\pm$ 12.9	0.081
Fasting glucose (mmol/l)	5.88 $\pm$ 1.58	5.74 $\pm$ 1.58	6.03 $\pm$ 1.60	0.455
TCHOL (mmol/l)	5.17 $\pm$ 0.92	5.16 $\pm$ 1.01	5.13 $\pm$ 1.13	0.907
Triacylglycerol (mmol/l)	1.48 $\pm$ 1.17	1.72 $\pm$ 1.11	2.15 $\pm$ 2.16	<0.001
HDL-C (mmol/l)	1.08 $\pm$ 0.28	1.06 $\pm$ 0.26	1.06 $\pm$ 0.32	0.737
Diabetes (%)	14.3	11.0	14.1	0.684
Hypertension (%)	53.1	42.9	56.5	0.127
Physical activity (%)				<0.001
None/seldom	26.8	46.2	50.0	
Regular	73.2	53.8	50.0	
Income(%)				<0.001
Low	45.2	52.7	69.7	
Middle	41.9	37.4	27.0	
High	12.9	9.9	3.4	
Education (%)				<0.001
Low	15.4	16.5	43.5	
Middle	36.7	53.8	48.9	
High	47.9	29.7	7.6	
Marital status (%)				0.016
Single (unmarried)	1.9	4.4	3.3	
Married	89.8	83.5	79.3	
Widower/divorce/separate	8.3	12.1	17.4	

ANOVA test was used for comparing mean values of continuous variables between groups, data were shown as means  $\pm$  s.d., Pearson's  $\chi^2$ -test was used for categorical data; data were shown as percentage.

BP, blood pressure; HDL-C, high-density lipoprotein cholesterol; HipC, hip circumference; TCHOL, total cholesterol; WC, waist circumference.

Table 3

Odds ratios (95% confidence interval) of having general and/or central obesity in several different models derived from a multiple logistic regression analysis using age, diabetes, hypertension, lipid profile, smoking, alcohol drinking, physical activity, income, and educational level as independent variables

Betel nut chewing-years (n)	Obesity	Model 1	Model 2	Model 3
None (n = 866)	General	1.00 (reference)	1.00 (reference)	1.00 (reference)
Low (n = 91)	General	1.68 (1.09, 2.59)*	1.53 (0.95, 2.48)	1.78 (1.07, 2.96)*
High (n = 92)	General	1.87 (1.21, 2.89) <sup>†</sup>	1.90 (1.16, 3.10)*	2.01 (1.18, 3.41)*
None (n = 866)	Central	1.00 (reference)	1.00 (reference)	1.00 (reference)
Low (n = 91)	Central	1.07 (0.68, 1.69)	1.03 (0.62, 1.71)	1.19 (0.70, 2.02)
High (n = 92)	Central	1.82 (1.18, 2.80) <sup>†</sup>	1.75 (1.06, 2.87)*	1.89 (1.10, 3.23)*

Betel nut chewing-years for chewers were categorized based on an equal distribution (low:  $\leq 76$  quids/day  $\times$  year; high:  $> 76$  quids/day  $\times$  year). Model 1: unadjusted. Model 2: adjusted for age, alcohol drinking, smoking, physical activity, income, and educational level. Model 3: adjusted for age, diabetes, hypertension, total cholesterol, high-density lipoprotein cholesterol, triacylglycerol, smoking, alcohol drinking, physical activity, income, and educational level. No interaction between betel nut chewing and smoking status for predicting the risk of general obesity ( $P = 0.517$ ) and central obesity ( $P = 0.148$ ); no interaction between betel nut chewing and alcohol drinking status for predicting the risk of general obesity ( $P = 0.407$ ) and central obesity ( $P = 0.725$ ).

\*  $P < 0.05$ ,

<sup>†</sup>  $P < 0.01$ ;

<sup>‡</sup>  $P < 0.001$ .

Table 4

Multiple linear regression analyses of betel nut chewing-years as a risk factor for the BMI and/or waist circumference

	BMI		WC	
	Coefficient	P value <sup>a</sup>	Coefficient	P value <sup>a</sup>
Betel nut chewing (quids/day-years) <sup>b,c</sup>				
High vs. none	0.867 ± 0.342	0.011	2.294 ± 0.947	0.016
Low vs. none	0.708 ± 0.332	0.033	-0.442 ± 0.921	0.631
Smoking (pack-years) <sup>b,c</sup>				
High vs. none	-0.113 ± 0.241	0.640	0.840 ± 0.668	0.209
Low vs. none	0.040 ± 0.226	0.858	0.666 ± 0.627	0.289
Alcohol drinking (drink-years) <sup>b,c</sup>				
High vs. none	0.134 ± 0.240	0.577	0.524 ± 0.665	0.431
Low vs. none	0.282 ± 0.227	0.216	0.312 ± 0.630	0.621
Age (years)	-0.030 ± 0.008	<0.001	0.033 ± 0.023	0.161
LnMAP (mm Hg) <sup>d</sup>	6.572 ± 0.690	<0.001	18.04 ± 1.912	<0.001
LnFasting glucose (mmol/l) <sup>d</sup>	0.788 ± 0.440	0.073	2.918 ± 1.219	0.017
TCHOL (mmol/l)	0.069 ± 0.110	0.528	0.365 ± 0.304	0.229
HDL-C (mmol/l)	-2.543 ± 0.373	<0.001	-7.317 ± 1.033	<0.001
LnTriacylglycerol (mmol/l) <sup>d</sup>	0.774 ± 0.187	<0.001	2.227 ± 0.519	<0.001

HDL-C, high-density lipoprotein cholesterol; MAP, mean arterial pressure; TCHOL, total cholesterol; WC, waist circumference.

<sup>a</sup>Using multiple linear regression analyses after adjusted for physical activity, income, and education level.

<sup>b</sup>Betel nut chewing-years for chewers, pack-years for smokers, and drink-years for drinkers were categorized based on an equal distribution (low ≤76 quids/day × year; high >76 quids/day × year for chewers; low ≤19.5 pack-years, high >19.5 pack-years for smokers; low ≤3.4 drink-year, high >3.4 drink-years for drinkers).

<sup>c</sup>Cumulative betel nut chewing, smoking, and alcohol drinking was divided into two dummy variables: high vs. none and low vs. none.

<sup>d</sup>Log transformation was done for normal distribution.

## Increased waist size and weight in relation to consumption of *Areca catechu* (betel-nut); a risk factor for increased glycaemia in Asians in East London

N. Mannan<sup>1</sup>, B. J. Boucher<sup>1\*</sup> and S. J. W. Evans<sup>2†</sup>

<sup>1</sup>Academic Medical Unit and Cellular Mechanisms Research Group and

<sup>2</sup>Department of Epidemiology and Medical Statistics, St Bartholomew's and The Royal London School of Medicine and Dentistry, Queen Mary Westfield College, London E1 1BB, UK

(Received 14 December 1998 – Revised 15 June 1999 – Accepted 17 August 1999)

Type 2 diabetes is commoner in Asians than Caucasians. Many nitrosamines are diabetogenic, causing both type 2 and type 1 diabetes. Of CDI mice fed with betel-nut or associated nitrosamines 8.5% develop glucose intolerance with marked obesity. Glycaemia and anthropometric risk markers for type 2 diabetes were therefore examined in relation to betel usage in 993 'healthy' Bangladeshis by one bilingual research-worker (N.M.). Of these, 12% had known diabetes. A further 145 of 187 subjects 'at-risk' of diabetes (spot glucose >6.5 mmol/l <2 h after food, or >4.5 mmol/l >2 h after food) had a second blood glucose sample taken; sixty-one were confirmed as 'at-risk', and had an oral glucose tolerance test; nine new diabetics were identified. Multiple regression analysis showed that spot blood glucose values decreased with time after eating ( $P=0.0005$ ) and increased independently with waist size ( $P=0.0005$ ) and age ( $P=0.0005$ ) without relationships to other aspects of the diet, season or smoking. Waist size was strongly related to betel usage independent of other factors such as age. Betel use interacted with sex, relating to increasing glycaemia only in females. Since waist and age were the major markers of increasing glycaemia we suggest that betel chewing, a habit common to about 10% of the world population (more than 200 million people) may contribute to the risk of developing type 2 diabetes mellitus.

### Central obesity: Betel-nut: Diabetes: Asians

British Asians have a 4–5-fold greater prevalence of type 2 (non-insulin-dependent) diabetes mellitus and develop the disease earlier than British Caucasians (Mather & Keen, 1985; World Health Organization, 1985; McKeigue *et al.* 1992). The causes of the greater numbers of foregut cancers, tumours of the oro- and nasopharynx, oesophagus and tongue seen in Asians compared with Caucasians include the chewing of betel-nut, fruit of the *Areca catechu* palm imported by expatriate Asian communities and eaten by 10% of the world population (Prokopczyk *et al.* 1987; Johnson, 1991; Encyclopaedia Britannica, 1996). Active carcinogens include specific arecal nitrosamines formed during curing and drying of the nut and *in vivo*, after acidification of arecal alkaloids by gastric juices (International Agency for Research on Cancer, 1992; Nishikawa *et al.* 1992). Many nitroso-compounds, including those previously found in smoked cured Icelandic mutton (Helgason *et al.* 1984) and toxins such as the rat poison

Vacor and streptozotocin, are diabetogenic both experimentally and in man (Karam *et al.* 1980; Okamoto *et al.* 1988). *N*-nitroso compounds are commonly thought of as inducing type 1 diabetes. However, whilst Vacor produced type 1 diabetes in thirty human survivors of toxic doses, only 20% of 250 survivors of smaller doses developed type 1 diabetes, 50% developing type 2 diabetes (Karam *et al.* 1980). Low-dose streptozotocin early in life can also induce a non-insulin-requiring form of diabetes (Portha *et al.* 1989). We have shown that diabetes develops in 8.5% of adult mice fed with betel-nut. The diabetes is non-insulin-dependent, associated with marked intra-abdominal fat deposition and enlarged and vacuolated islets as seen in human type 2 diabetes (Boucher *et al.* 1991, 1994). We suggested that betel-nut consumption might contribute to the development of diabetes in man either directly or by an effect on body build. The present study, a cross-sectional survey of adult British Asians of Bangladeshi origin, was

Abbreviation: OGTT, oral glucose tolerance test.

\* Corresponding author: Dr Barbara J. Boucher, fax +44 (0)171 377 7636, email B.J.Boucher@rmds.qmw.ac.uk

† Present address: The Quintiles, Battle, East Sussex, TN33 0TX.

1944

carried out to determine whether there was a relationship between glycaemia or central obesity (as a marker of risk for type 2 diabetes; McKeigue *et al.* 1992) and betel-nut consumption. Since vitamin D is required for normal insulin secretion and release, vitamin D deficiency is still seen in UK Asians and vitamin D status affects insulin response to glucose both experimentally and in man (Bansal *et al.* 1975; Gedik & Akalan, 1986; Boucher *et al.* 1995), the consumption of foods on which this population depends for vitamin D was also investigated as a possible confounder.

### Methods

The study was approved by the District Ethical Committee and details were agreed with participating family practitioners. British Asian adults of Bangladeshi extraction ( $n$  1000), resident in Tower Hamlets, East London, were contacted randomly as 'well' attenders at their family practitioners' surgeries. Of these, 993 subjects giving informed consent were interviewed by a single worker (N.M.). A questionnaire was administered on dietary habits, including the use of betel-nut (plain or wrapped in piper betel vine leaves as pan-quids), age of first usage and whether either parent had chewed betel (see Appendix). A personal and parental history of diabetes was taken and measurements made of height (with a single fixed scale), weight (with a single weighing scale) and waist and hip size using standard techniques (McKeigue *et al.* 1992). Blood glucose concentration was measured on a spot fingertip capillary blood sample using BM 1-44 stix and a Reflolux meter (Boehringer Mannheim UK, Lewes, Sussex, UK; CV <10%), validated using glucose-oxidase specific spectrometry (Beckman Technical Institute, Palo Alto, CA, USA; CV <3%). A total of 116 subjects (12%) reported known diabetes. Subjects ( $n$  187) not previously known to have diabetes, and defined as 'at-risk' of diabetes by capillary blood glucose concentrations of >6.5 mmol/l less than 2 h after food, or >4.5 mmol/l more than 2 h after food (screening levels found to be effective for detection of diabetes in other UK Asians; Simmonds *et al.* 1991), were invited to reattend for repeat spot sampling. Sixty-one of the 145 reattenders were still 'at-risk' and forty-four agreed to undergo a standard oral glucose tolerance test (OGTT),

which revealed nine of these subjects to have diabetes (World Health Organization, 1985). One test was abandoned because of vomiting. Forty-two of the forty-four 'at-risk' subjects undergoing an OGTT were vitamin D deficient (serum 25-hydroxycholecalciferol <11 ng/l). Twenty-two of these subjects accepted treatment with vitamin D, and were re-studied as reported elsewhere (Boucher *et al.* 1995). Statistical analyses included examination of means and their differences by  $t$  tests, and the use of multiple regression (to  $P < 0.05$ ). The skewed distribution of spot blood glucose concentration was corrected by inverse transformation ( $100 - 100/\text{glucose}$ , mmol/l) for analysis, reducing the dependency of the findings on values at the extremes of observation (see Fig. 2). This method achieved normalization of the distribution of the data more effectively than log transformation and resulted in regressions in the same direction as those produced by analyses made with the untransformed data. The computer program STATA, version 4.0, (Stata Corporation, College Station, TX, USA) was used for the analyses on an IBM-compatible computer.

Questionnaire evidence of betel-nut usage and of dietary vitamin D intake was validated as follows: (1) by measurement of urinary arecal nitrosamines (carried out by Dr J. Pollock, Pollock & Pool plc, Reading, Berks., UK) in twenty 'pan-chewers' and twenty 'non-chewers' as identified from responses to the questionnaire; (2) by examination of serum 25-hydroxycholecalciferol concentration (measured by radioimmunoassay; Incstar, Seattle, MN, USA) at OGTT in relation to stated dietary intake of fish and eggs; and (3) by examination of circulating serum fish-oil components at OGTT in relation to vitamin D status and to stated fish consumption on questionnaire as reported elsewhere (Mannan, 1992).

### Results

Table 1 shows the overall findings for age, height, weight, waist, hip, BMI, waist:hip ratio and spot blood glucose concentration in the 988 men and women who completed the questionnaire, had screening blood test(s) and underwent anthropometric measurements. Specific arecal nitrosamines were detected in nine of twenty spot urine samples

Table 1. Age, weight, height, waist circumference, hip circumference, body mass index, waist:hip ratio, spot blood glucose concentration and blood glucose concentration corrected to 2 h after food in men and women surveyed in the present study (Mean values, standard deviations and ranges)

Variable	Men ( $n$ 466)			Women ( $n$ 522)		
	Mean	SD	Range	Mean	SD	Range
Age (years)	44.8	14.9	15-83	37.0	12.4	15-70
Weight (kg)	66.0	10.8	35.5-112.0	56.4	10.6	21.5-95.0
Height (m)	1.648	0.061	1.46-1.83	1.514	0.049	1.35-1.67
Waist circumference (cm)	87.0	10.5	61-118	80.0	10.9	51-113
Hip circumference (cm)	91.1	6.7	72-116	91.4	8.3	69-122
BMI (kg/m <sup>2</sup> )	24.3	3.6	16.4-35.3	24.6	4.4	10.8-42.9
Waist:hip ratio	0.95	0.07	0.70-1.18	0.87	0.07	0.70-1.10
Spot blood glucose (mmol/l)	6.3	3.2	2.1-27.1	5.7	2.5	2.3-22.8
Blood glucose (corrected to 2 h after food) (mmol/l)	6.4	3.2	2.1-27.1	5.8	2.4	2.3-22.8

1245

from stated pan or betel chewers and in none of twenty samples from stated non-chewers. Both serum 25-hydroxycholecalciferol and serum 4,7,10,13,16,19-decanoic hexaenoic acid of fish origin had earlier been shown to be related to stated fish intake in the subjects undergoing a full OGTT in the present study (Mannan, 1992). Spot blood glucose concentration (corrected to 2 h after food) correlated significantly with 2 h OGTT plasma glucose in the forty-four 'at-risk' subjects ( $r\ 0.55, P=0.01$ ). Pan consumption was reported in 75.2% of subjects at 1-22 quids/d and plain betel was used by a further 2% of subjects. Fig. 1 shows the prevalence of consumption of areca (betel-nut) and of previously known diabetes in relation to age and sex.

Analyses of waist size and weight v. pan consumption showed its usage to be independently associated with increases in waist circumference of 23 mm in men and women and with increases of weight averaging 2.8 kg in

both men and women (0.8 kg after correction for increases in waist size) as shown in Tables 2 and 3. There was no seasonal variation in corrected screening blood glucose concentration before or after correction for age, waist, weight, sex and height. Reported pan usage was greater for parents of men than of women (95% of mothers and 90% of fathers v. 84% of mothers and 71% of fathers respectively). These differences could be accounted for by the fact that the men surveyed were 7.8 years older than the women and betel-nut usage increases up to the age of about 55 years (see Fig. 1). There was no independent effect of parental pan usage on the presence of diabetes, on waist or hip size, waist:hip ratio, weight or height.

Multiple regression was also used to examine the association of spot blood glucose concentration with pan usage adjusting for recognized confounding variables. Regression models which allowed for time from last meal, height, weight, waist size, age and sex as well as pan consumption

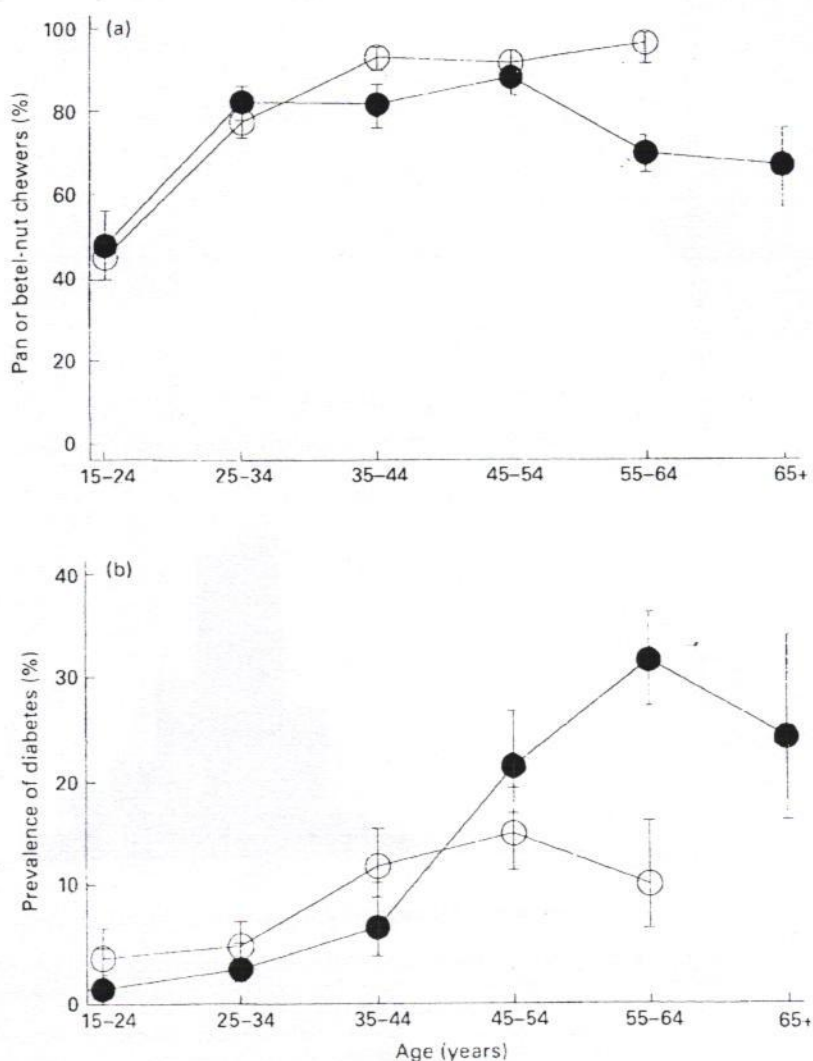

Fig. 1. (a) Prevalence of betel-nut or pan usage and (b) prevalence of previously known diabetes in groups of men (●) and women (○) of different ages. Subjects were of Bangladeshi origin and lived in Tower Hamlets, London. Values are shown with binomial exact 68% confidence limits.

1248  
B

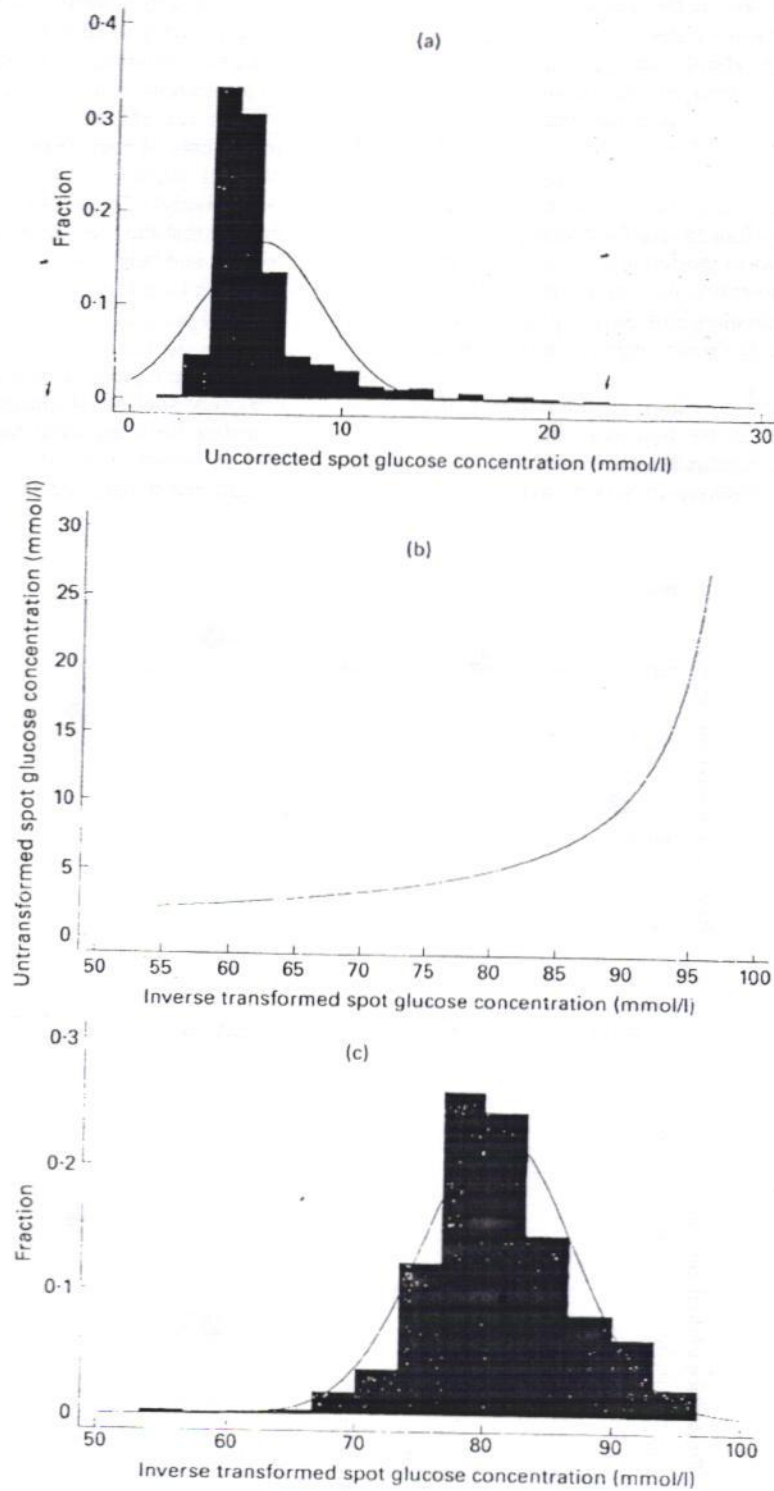

Fig. 2. (a) Skewed distribution of spot blood glucose concentration (mmol/l) in 988 subjects of Bangladeshi origin living in Tower Hamlets, London. (b) Relationship between untransformed spot blood glucose concentration and 'inverse' or transformed spot blood glucose concentration ( $100 - 100/\text{blood glucose}$ ; mmol/l) in the same subjects. (c) Normalized distribution of the 'inverse' or transformed blood glucose concentration values.

1247  
E

**Table 2.** Multiple regression analysis of transformed (inverse) spot blood glucose concentrations\* v. weight, waist circumference, interval after eating, age, sex, pan or betel consumption and sex x pan interaction in 988 subjects of Bangladeshi origin

(Coefficients with their standard errors, *t* and *P* values and 95% confidence intervals)

	Change in inverse glucose per unit variable				
	Coefficient	SE	<i>t</i>	<i>P</i>	95% CI
Weight (per kg)	-0.081	0.029	2.76	0.006	-0.14, -0.023
Waist (per cm)	0.174	0.03	5.59	0.0005	0.11, 0.24
Interval after meal (per h)	-0.38	0.07	-5.26	0.0005	-0.52, -0.24
Age (per year)	0.08	0.15	5.44	0.0005	0.05, 0.11
Sex (female v. male)	-1.23	0.73	-1.69	0.091	-2.66, 0.19
Pan (yes v. no)	-1.69	0.57	-2.98	0.003	-2.8, -0.58
Sex x pan interaction†	2.11	0.8	2.63	0.009	0.53, 3.67
Constant	70.29	1.5	47.86	0.0005	67.4, 73.15

\* Inverse glucose concentration =  $100 - 100/\text{blood glucose (mmol/l)}$ .

† See p. 268.

(yes or no) or for numbers of pan quids used per day (0–22) were used. Linearity was checked and interactions of sex and other variables were tested. The best fitting model (see Tables 2 and 3) included interval after eating, waist size and age. Spot blood glucose concentrations were independently reduced with time after eating ( $P=0.0005$ ) but increased with age ( $P=0.0005$ ) and waist size ( $P=0.0005$ ). No additional contribution was made by height, hip size, waist:hip ratio, fish and egg intake or smoking in men or women. Spot glucose concentration was found to be somewhat lower with increasing weight, but where waist and weight are highly correlated as in this population, then, for a given waist size, the higher the weight the lower the glucose. These findings were not altered by the exclusion of all subjects with diabetes (i.e. known diabetics plus those diagnosed in the study). Neither sex nor pan consumption had a significant effect on blood glucose on its own. There was, however, a significant interaction between the effects of pan usage and sex, with some reduction in glucose concentrations in male pan chewers but significant increases in glucose concentrations in female pan chewers, analyses having been made

after adjustment for all other variables under consideration (see Table 2). Table 3 shows the same findings using untransformed blood glucose values. In order to demonstrate that variation of magnitude of this effect becomes more marked at increasing levels of glycaemia (see Fig. 2b).

### Discussion

The number of subjects studied represented 2.7% of Asians resident in Tower Hamlets as estimated by the 1991 census (Office of Population Censuses and Surveys, 1991). Since 50% of this community is under 16 years old and our subjects were all older than 16 years, approximately 4.5% of local adult Asians were surveyed. The 12% prevalence of known diabetes (which together with the 2% newly found diabetics gave a minimum prevalence of diabetes of 14%) was similar to that found in other British Asian communities. The survey sample was therefore likely to be representative of the local Bangladeshi community (Mather & Keen, 1985; World Health Organization, 1985; McKeigue *et al.* 1992). The 2% prevalence of undiagnosed diabetes was a smaller

**Table 3.** Multiple regression analysis of untransformed spot blood glucose concentrations (mmol/l) v. weight, waist circumference, interval after eating, age, sex, pan or betel consumption and sex x pan interaction in 988 subjects of Bangladeshi origin

(Coefficients with their standard errors, *t* and *P* values and 95% confidence intervals)

	Change in inverse glucose per unit variable				
	Coefficient	SE	<i>t</i>	<i>P</i>	95% CI
Weight (per kg)	-0.47	0.15	-3.24	0.001	-0.76, -0.19
Waist (per cm)	0.087	0.15	5.61	0.0005	0.06, 0.12
Interval after meal (per h)	-0.13	0.04	-3.72	0.0005	-0.2, -0.06
Age (per year)	0.04	0.007	5.46	0.0005	0.03, 0.05
Sex (female v. male)	-0.66	0.36	-1.83	0.068	-1.34, -0.05
Pan (yes v. no)	-0.71	0.28	-2.51	0.012	-1.26, -0.15
Sex x pan interaction*	0.73	0.39	1.83	0.068	-0.05, 1.51
Constant	0.98	0.73	1.35	0.178	-0.45, 2.42

\* See p. 268.

1248  
8

proportion of total diabetes prevalence than that found on screening white populations in the UK (averaging 50%). It is, however, comparable with earlier findings in Asians (Mather & Keen, 1985; Simmonds *et al.* 1991), who may be more symptomatic, attend their doctors earlier or attract earlier screening as a known high-risk group.

Confidence in the questionnaire data is enhanced by the fact that it was obtained by a Sylheti-speaking member of the local community and by the quantitative assessments made. The negative relationship of 'spot' blood glucose measurements to questionnaire-derived interval after eating provides useful confirmation of the validity of these findings, as does the positive relationship of the 'spot' blood glucose values with 2 h venous plasma glucose at OGTT.

The prevalence of pan usage increased with age. More women than men chewed pan at all ages and women ate more quids daily than men, which could account for the finding that pan consumption relates to increases in glycaemia in women but not in men. The lesser pan usage reported for parents of the women studied compared with those of the men reflects the fact that the women surveyed were younger than the men, since usage in younger Asians is believed to be falling in the UK (Bedi *et al.* 1995). The reduction in pan usage in men over 55 years was modest but raises the possibility that betel usage, known to be carcinogenic (International Agency for Research on Cancer, 1992; Nishikawa *et al.* 1992), may be associated with the increased death rates seen in this population which are largely from IHD, a well-recognized problem in people with diabetes (Balarajan, 1991). Alternatively older betel-nut users may be more likely than non-users to return to Bangladesh, or the prevalence could be falling with calendar year of birth at all ages, a cohort effect that cannot be studied in a single cross-sectional study. The fall in prevalence of diabetes in men over 64 years and women over 54 years was not significant but is in keeping with the generally accepted view that diabetes is associated with early death in Asians even more markedly than in whites, although again, this could reflect a tendency for older people with diabetes to leave Britain.

Our findings confirm that increased waist size is a better risk marker for hyperglycaemia than hip circumference, height or waist:hip ratio in Bangladeshi Asians. The reduction in glycaemia with increasing weight must be interpreted with caution since, as in any analysis using multiple regression, this relationship is calculated for constant values of the other factors (such as waist, age and time after eating) used in the analyses, and heavier people are likely to be taller for a given waist than lighter people. Height is generally regarded as a protective factor for diabetes although it was not independently related to glycaemia in the present study.

The specific and independent relationships found for pan consumption with anthropometric markers of diabetes risk, and with glycaemia, are of interest since the non-betel-fed F1-F4 descendants of short-term betel-fed CD1 mice that develop glucose intolerance are markedly obese. This is especially obvious intra-abdominally, with enlarged islets showing abnormalities similar in appearance to those found in human type 2 diabetes (Boucher *et al.* 1994). Since experimental betel feeding is associated with obvious

damage to sperm heads and to the ova of betel-fed animals on light microscopy, it is clear that arecal agents target the gametes (Dave *et al.* 1992; Mukherjee *et al.* 1993). These findings suggest that neither cross-sectional nor single generational studies would be capable of detecting any genetic effect of betel use in increasing susceptibility to type 2 diabetes in man, betel-nut having been in widespread use in many communities for over 5000 years. The impact of as yet unknown betel-induced genetic changes will therefore require elucidation for this aspect of the proposed hypothesis of the diabetogenicity of betel-nut consumption to be pursued. The situation is further complicated by the possibility that susceptibility to betel-nut diabetogenicity could itself be genetically determined in man as is the case for the diabetogenic nitroso-compound streptozotocin in the mouse where susceptibility depends on the H2 region of the major histocompatibility complex (Kiesel *et al.* 1989; Tanaka *et al.* 1990).

There are several possible confounding factors that require further study. For example the leaves used as wraps for pan quids contain  $\beta$ -carotene (Dr J. Pollock, personal communication) which inhibits nitroso-compound carcinogenicity and diabetogenicity in animals. These leaves also contain hydroxy-chavicol, which, like the betel-nut alkaloid arecaine, is a hypoglycaemic agent (Stitch *et al.* 1991). It is also impossible to allow for any unidentified maternal diabetes, or gestational diabetes, for early death in those with diabetes (and perhaps also of those who chew betel-nut) or for the inability to identify normoglycaemic subjects who will later develop diabetes.

Whilst we have reported effects of vitamin D status on insulin secretion and glycaemia in a subset of our subjects, both in those 'at-risk' and 'not-at-risk' of diabetes, the absence of independent effects of season or of fish and egg intake on glycaemia (other than in the vitamin D-deficient subgroup already reported; Boucher *et al.* 1995), suggests that vitamin D status was not likely to be contributing to determination of glycaemia (or to be confounding the findings) in the group as a whole. The major confounder is of course likely to be pan usage in parents and earlier progenitors which could have increased susceptibility to diabetes by as yet unidentified genetic mechanisms. Cross-sectional studies should prove more powerful for the investigation of the diabetogenicity of recently introduced dietary nitroso-compounds than for those used over generations in man such as betel-nut.

The direct association between waist size and pan usage is, however, of special interest since we found waist size to be the best predictor of hyperglycaemia after age and sex in the present study, as in previous studies (Sheligar *et al.* 1991). The pan  $\times$  sex interaction with an association between betel usage and increased glycaemia in women but with reduced glycaemia in men, whilst associated with greater pan usage in women, could reflect differences in susceptibility to diabetogenic nitroso-compounds between the sexes. We suggest that the use of betel-nut in pan quids adds to the risk of type 2 diabetes through increased central obesity. In addition it is clear that studies on the possible diabetogenicity of nitroso-compounds used in the diet are less likely to reveal any associations where the mechanisms involved may be genetic, and the agent has been in use

1249  
8

for generations, than are studies on compounds recently introduced into the diet.

### References

- Balarajan R (1991) Ethnic differences in mortality from ischaemic heart disease and cerebrovascular disease in England and Wales. *British Medical Journal* **302**, 560–564.
- Bansal S, Rizvi SNA, Rao MB & Vaishnava H (1975) Effect of hypocalcaemia on glucose tolerance, insulin release and free fatty acid levels in human subjects. *Postgraduate Medical Journal* **52**, 471–475.
- Bedi R & Gilthorpe MS (1995) Betel-quinid and tobacco chewing among the Bangladeshi community in areas of multiple deprivation. In *Betel-quinid and Tobacco Chewing Among the Bangladeshi Community in the United Kingdom*, 1st ed., pp. 37–52 [R Bedi and P Jones, editors]. London: Centre for Transcultural Oral Health.
- Boucher BJ, Ewen SWB & Stowers JM (1991) Betel nut (*Areca catechu*) consumption as an aetiological agent for diabetes mellitus; studies in CD1 mice and their offspring. *Diabetic Medicine* **8**, Suppl. 1, P4 Abstr.
- Boucher BJ, Ewen SWB & Stowers JM (1994) Betel nut (*Areca catechu*) consumption and the induction of glucose intolerance in adult CD1 mice and in their F1 and F2 offspring. *Diabetologia* **37**, 49–55.
- Boucher BJ, Mannan N, Noonan K, Hales CN & Evans SJW (1995) Glucose intolerance and impairment of insulin secretion in relation to vitamin D deficiency in East London Asians. *Diabetologia* **38**, 1239–1245.
- Dave BJ, Trivedi AH & Adhvaray SG (1992) In vitro toxic effects of areca nut extract and arecoline. *Journal of Cancer Research and Clinical Oncology* **118**, 283–288.
- Encyclopaedia Britannica (1996) Encyclopaedia Britannica Online. Areca catechu (betel-nut). <http://www-lj.eb.com>
- Gedik O & Akalan S (1986) Effects of vitamin D deficiency and depletion on insulin and glucagon secretion in man. *Diabetologia* **29**, 142–145.
- Helgason T, Ewen SWB, Jaffrey B, Stowers JM, Outram JR & Pollock JR (1984) N-nitrosamines in smoked meats and their relation to diabetes. In *IARC Scientific Publications* no. 57, pp. 911–920. Lyon: IARC.
- International Agency for Research on Cancer (1992) *Monographs on the Evaluation of Carcinogenic Risk of Chemicals to Humans: Tobacco Habits Other Than Smoking; Betel-quinid and Areca-nut Chewing, and Some Related Nitrosamines*. IARC (WHO) *Monographs* no. 37. Lyon: IARC.
- Johnson NW (1991) Orofacial neoplasms: global epidemiology, risk factors and recommendations for research. *International Dental Journal* **41**, 365–375.
- Karam JH, Lewitt PA, Young CW, Nowlain RE, Frankel BJ, Fujiya H, Freedman ZR & Grodssky GM (1980) Insulinopenic diabetes after rodenticide (Vacor) ingestion. *Diabetes* **29**, 971–978.
- Kiesel U, Oschilewski M, Taniguchi M & Kolb H (1989) Modulation of low-dose streptozotocin-induced diabetes in mice by administration of antibodies to IA, IE and IL determinants. *Diabetologia* **32**, 173–176.
- McKeigue PM, Pierpoint T, Ferrie JE & Marmot MG (1992) Relationship of glucose intolerance and hyperinsulinaemia to body fat pattern in South Asians and Europeans. *Diabetologia* **35**, 785–791.
- Mannan N (1992) Vitamin D status and its relationship to insulin levels in the Bangladeshi community of Tower Hamlets and to the contribution of fish oil to the diet. MSc Thesis, University of London.
- Mather PH & Keen H (1985) The Southall Diabetes Survey; prevalence of known diabetes in Asians and Europeans. *British Medical Journal* **291**, 1081–1084.
- Mukherjee A, Chakrabarti J, Chakrabarti A, Banerjee T & Sarma A (1993) Effect of 'Pan Masala' on the germ cells of male mice. *Cancer Letters* **58**, 161–165.
- Nishikawa A, Prokopczk B, Rivenson A, Zang E & Hoffman D (1992) A study of betel-quinid carcinogenesis. VIII. Carcinogenicity of 3-(methylnitrosoamino) propionaldehyde in F344 rats. *Carcinogenesis* **13**, 369–372.
- Office of Population Censuses and Surveys (1991) *Census User Guide 3: Local Statistics and Small Area Statistics*. London: H.M. Stationery Office.
- Okamoto H, Yamamoto S, Takasawa S, Inoue C, Terazono K, Shiga K & Kitagawa M (1988) Molecular mechanisms of degeneration, oncogenesis and regeneration of pancreatic B-cells of islets of Langerhans. In *Frontiers in Diabetes Research: Lessons From Animal Diabetes*, pp. 149–157 [A Shafir and AE Renold, editors]. London: John Libby & Co.
- Portha B, Blondel O, Serradas P, McEvoy R, Giroix MH, Kergoat M & Bailbe D (1989) The rat models of non-insulin-dependent diabetes induced by neonatal streptozotocin. *Diabete et Metabolisme* **15**, 61–75.
- Prokopczk BP, Rivenson A, Bertinato P, Brunnemann KD & Hoffman D (1987) 3-(Methylnitrosoamino) propionitrile: occurrence in saliva of betel-chewers, carcinogenicity and DNA methylation in F344 rats. *Cancer Research* **47**, 467–471.
- Sheligar KM, Hockaday TDR & Yajnik CS (1991) Central rather than generalised obesity is related to hyperglycaemia. *Diabetic Medicine* **8**, 712–717.
- Simmonds D, Williams DRR & Powell MJ (1991) The Coventry Diabetes Study: prevalence of diabetes and impaired glucose tolerance in Europeans and Asians. *Quarterly Journal of Medicine* **296**, 1021–1030.
- Stitch HF, Mathew B, Sankaranarayanan R & Nair MK (1991) Remission of oral precancerous lesions of tobacco/areca nut chewers following administration of beta-carotene or vitamin A, and maintenance of the protective effect. *Cancer Detection and Prevention* **15**, 93–98.
- Tanaka SI, Nakajima AS, Inoue S, Takamura Y, Aoki I & Okuda K (1990) Genetic control by Ia subregions on H-r complex of incidence of streptozotocin induced autoimmune diabetes in mice. *Diabetologia* **39**, 1298–1304.
- World Health Organization (1985) *WHO Study Group Report on Diabetes Mellitus. Technical Report Series* no. 727. Geneva: WHO.

## Appendix

Name ..... Hospital record no. ....  
 নাম ..... হাসপাতাল নং: .....  
 Age ..... Date of birth ..... Parity .....  
 বয়স ..... জন্ম তারিখ ..... সন্তানের সংখ্যা .....  
 Weight (kg) ..... Height (cm) ..... Waist (cm) ..... Hips (cm) .....  
 ওজন ..... উচ্চতা ..... পেট ..... কোমর .....

1. Which type of cooking oil do you use?

১. আপনি রান্নায় কোন তৈল ব্যবহার করেন ?

corn কর্ন   
 vegetable ভেজিটেবিল   
 sunflower সানফ্লাওয়ার   
 mustard শরিসা   
 other অন্য .....

2. Do you use ghee in cooking ?

২. আপনি কি রান্নায় ঘি ব্যবহার করেন ?

yes হ্যাঁ  no না

3. Do you eat eggs ?

৩. আপনি কি ডিম খান ?

yes হ্যাঁ  no না

How many do you eat/week?

সপ্তাহে কয়টা ডিম খান ? .....

4. Are you vegetarian ?

৪. আপনি কি শুধু নিরামিষ খান ?

yes হ্যাঁ  no না

5. Do you eat fish ?

৫. আপনি কি মাছ খান ?

yes হ্যাঁ  no না

Which type of fish do you eat ?

কি কি মাছ খান ?

fabia পাৰদা  hilsa ইলিশ   
 roi বুই  chitol চিতল   
 bual বোয়াল  fangash পান্ডাস   
 ayr আইর  basa বাছা   
 koi কৈ  sardine সার্ডিন   
 small fish ছোট মাছ  other অন্য

How many times /week do you eat fish?

সপ্তাহে কত দিন মাছ খান ? .....

What is your favourite fish?

আপনার প্রিয় মাছ কোন টি ? .....

6. Do you eat meat ?

৬. আপনি কি মাংস খান ?

yes হ্যাঁ  no না

If yes, which type of meat ?

যদি খান, কি রকম মাংস খান ?

mutton ভেড়ি  yes হ্যাঁ  no না  How many times/week ?  
 সপ্তাহে কত দিন খান ? .....

chicken with skin মোরগ চামড়া সহ  yes হ্যাঁ  no না  How many times/week ?  
 সপ্তাহে কত দিন খান ? .....

chicken without skin মোরগ চামড়া ছাড়া  yes হ্যাঁ  no না  How many times/week ?  
 সপ্তাহে কত দিন খান ? .....

7. Do you eat pan ?

৭. আপনি কি পান খান ?

yes হ্যাঁ  no না

1257

If no, do you eat plain betel ? yes no  
 যদি পান খান না, আপনি কি শুধু সুপারি খান ? হ্যাঁ  না

If yes, age of first use ?  
 যদি পান/ সুপারি খান, কত বয়স থেকে খেতে শুরু করছেন ? .....

How many times /day do you chew betel ?  
 দিনে কত বার সুপারি খান ? .....

How long do you keep it in your mouth ?  
 কত সময় সুপারি চিবান ? .....

Which side of your mouth do you keep it on ? Right Left Same on both sides  
 মুখের কোন পাশে সুপারি বেশীক্ষন রাখেন ? ডান  বাঁ  দুই দিকে সমান

8. Do/did either of your parents use pan/betel ? yes no  
 ৮. আপনার মা বাবা কি পান সুপারি খান/খেতেন ? হ্যাঁ  না

If yes, mother yes no  
 যদি হ্যাঁ, মা খান/খেতেন হ্যাঁ  না

father yes no  
 বাবা খান/খেতেন হ্যাঁ  না

9. Do you drink tea or coffee ?  
 ৯. আপনি কি চা/কফি খান ?

Tea yes no How many cups/day?  
 চা হ্যাঁ  না  দিনে কত বার ? .....

Coffee yes no How many cups/day?  
 কফি হ্যাঁ  না  দিনে কত বার ? .....

10. Do you take sugar in tea/coffee? yes no If yes, how many teaspoons/cup ?  
 ১০. চা বা কফিতে কি চিনি খান ? হ্যাঁ  না  যদি হ্যাঁ, এক কাপে কত চামচ ? .....

Which type of sugar do you take ? White Brown  
 কোন ধরণের চিনি খান ? সাদা  বাদামি

Do you use other sweeteners such as,  
 চিনির পরিবর্তে অন্য কিছু ব্যবহার করেন কি, যেমন, gur (treacle) গুড়   
 honey মধু   
 other অন্য .....

11. Do you eat greens? yes no  
 ১১. আপনি কি শাগ পাতা খান ? হ্যাঁ  না

If yes, which kinds of greens ?  
 যদি হ্যাঁ, তাহলে কি কি শাগ পাতা খান ?

jute নালি শাগ   
 spinach স্পিনাস   
 mustard লাই পাতা   
 cabbage কবির পাতা   
 other অন্য .....

12. Do you smoke ? yes no  
 ১২. আপনি কি ধূম পান করেন ? হ্যাঁ  না

## A population-based study of the association between areca nut chewing and Type 2 diabetes mellitus in men (Keelung Community-based Integrated Screening programme No. 2)

T.-H. Tung<sup>1</sup> · Y.-H. Chiu<sup>2</sup> · L.-S. Chen<sup>2</sup> · H.-M. Wu<sup>3</sup> · B. J. Boucher<sup>4</sup> · T. H.-H. Chen<sup>5</sup>

<sup>1</sup> Department of Medicine Research and Education, Cheng Hsin Rehabilitation Center, Taipei, Taiwan

<sup>2</sup> Institute of Health Informatics and Decision Making, School of Medicine, National Yang-Ming University, Taipei, Taiwan

<sup>3</sup> Graduate Institute of Epidemiology, College of Public Health, National Taiwan University, Taipei, Taiwan

<sup>4</sup> Centre for Diabetes and Metabolic Medicine, St Bartholemew's and the Royal London School of Medicine and Dentistry, Queen Mary and Westfield College, London, UK

<sup>5</sup> Institute of Preventive Medicine, College of Public Health, National Taiwan University, Taipei, Taiwan

### Abstract

**Aims/hypothesis.** The aim of this study was to assess whether the diabetogenicity of areca nut (*Areca catechu* or 'betel-nut'), which has previously been demonstrated experimentally in mice, independently contributes to the risk of hyperglycaemia or Type 2 diabetes in men in Taiwan, where the habit has become established relatively recently.

**Methods.** We used data from a population-based cross-sectional survey and a multiple-disease-screening programme that tested for hyperglycaemia, Type 2 diabetes and risk factors related to Type 2 diabetes. Data on habitual areca nut chewing were available for 14,816 men. Multiple logistic regression models were used to determine whether areca nut chewing was an independent risk factor for Type 2 diabetes.

**Results.** Compared with non-chewers, areca nut chewers had higher age-adjusted prevalence rates for hyperglycaemia (11.4% vs 8.7%) and Type 2 diabetes (10.3% vs 7.8%). Areca nut chewing independently

increased the risk of hyperglycaemia (adjusted odds ratio [OR] 1.19, 95% CI 0.97–1.45) and Type 2 diabetes (adjusted OR 1.29, 95% CI 1.04–1.60). The independent effects of duration of chewing were dose-dependent for Type 2 diabetes (adjusted OR 1.32 for the duration of 10–19 years and 1.41 for the duration of  $\geq 20$  years), as were the effects of increased rates of areca nut chewing (adjusted OR 1.14 for  $< 10$  pieces/day, 1.30 for 10–19 pieces/day and 2.02 for  $\geq 20$  pieces/day); similar findings were noted for hyperglycaemia.

**Conclusions/interpretation.** The habit of chewing areca nut independently contributes to the risk of both hyperglycaemia and Type 2 diabetes in Taiwanese men. This association is dose-dependent with respect to the duration of areca nut use and the quantity of areca nut chewed per day.

**Keywords** Areca nut · Betel · Hyperglycaemia · Type 2 diabetes

Received: 7 January 2004 / Accepted: 1 June 2004

Published online: 27 October 2004

© Springer-Verlag 2004

T. H.-H. Chen (✉)

Institute of Preventive Medicine, College of Public Health,  
National Taiwan University, No. 19, Hsu-Chow Rd, Taipei,  
Taiwan

E-mail: stony@episerv.cph.ntu.edu.tw

Tel.: +886-2-23587620

Fax: +886-2-23587707

**Abbreviations:** BUN, blood urea nitrogen · KCIS, Keelung Community-based Integrated Screening · LRT, likelihood ratio testing · OR, odds ratio

### Introduction

In Taiwan, areca nut chewing has become one of the most popular lifestyle habits over the last 40 years. The habit of chewing the nut of the *Areca catechu* palm is commonly referred to in English as 'betel-chewing', a term arising from the use of leaves from the creeping vine *Piper betle* to wrap up chopped nuts to form quids. *Areca catechu* is currently used by about 2 million Taiwanese people (approximately 10% of the population), particularly the male 'blue collar' workers and those with low levels of education [1]. The main varieties of chews used in Taiwan are those prepared by combining unripe areca fruit with a

1253

piece of the inflorescence (flower head) of the *Piper betle* vine and red lime paste, or by wrapping unripe areca fruit in leaves of the *Piper betle* vine with white lime paste [2]. It should be noted that no tobacco is added to the chews used in Taiwan.

Chewing areca nut has been found to significantly contribute to the development of oral cancer [3, 4], primary hepatocellular cancer [5, 6] and oesophageal carcinoma [7]. In addition, the arecal nitrosamines formed from the specific arecal alkaloids [8, 9] have been shown to be carcinogenic experimentally. Many nitrosamines are diabetogenic, and it has been suggested that arecal nitrosamines may be diabetogenic in man [10]. However, no population-based studies investigating the direct relationship between areca nut chewing and Type 2 diabetes have been performed to date. The habit of areca nut chewing is now common among Taiwanese men but, like Type 2 diabetes, this has only occurred over the last 20+ years. This reduces the risk of confounding due to the possible inheritability of the diabetogenic effects of areca nut (as previously reported in experimental animals [9]) or of parental diabetes [11] in this population. This is of particular importance since the habit has been common for 2000 years or more in virtually all other countries where areca nut is used. Based on this fact, the aim of the present study was to investigate the dose-dependent effects of areca nut on the development of Type 2 diabetes in the Taiwanese population.

## Subjects and methods

**Study subjects.** All data were derived from the Keelung Community-based Integrated Screening (KCIS) programme. This was a multiple-disease-screening programme that was carried out in Keelung, the northernmost county of Taiwan, between 1 January 1999 and 31 December 2001. Details of the study design and some preliminary results have been described elsewhere [12]. Briefly, a total of 42 387 subjects (including 15,097 men and 27,290 women) were enrolled in the KCIS programme and attended a screening for Type 2 diabetes. Subjects with hyperglycaemia or Type 2 diabetes were diagnosed according to the criteria of the American Diabetic Association (ADA) as defined in 1999 [13]. Subjects with fasting plasma glucose levels of  $\geq 6.1$  mmol/l were defined as having hyperglycaemia and those with fasting plasma glucose levels of  $\geq 7.0$  mmol/l were defined as having Type 2 diabetes. Patients with previously diagnosed Type 2 diabetes were identified by questionnaire. As only 231 women either reported the use of areca nut or were ex-chewers, the present study focused on males alone. After the exclusion of a further 281 male subjects with incomplete data for areca nut use, the final study population on which the present analyses were based consisted of 14,816 subjects. This project was approved by the local health committee, which is run by the Taiwan Community-based Integrating Group [12]. Subjects gave their consent to participate in the on-site KCIS screening after being fully informed about the survey by public health nurses with formal documentation in Chinese.

**Data collection.** Data on behavioural risk factors (smoking, alcohol intake and areca nut chewing) were collected at one-to-one interviews using a structured questionnaire. The main type of areca nut chews used in Keelung city are the so-called 'Lao-Hwa', which are prepared by combining portions of unripe areca nut with a piece of the inflorescence (flower head) of the *Piper betle* vine and red lime paste [2]. Subjects were divided into three categories according to areca nut use: (i) current chewers; (ii) non-chewers (never); and (iii) ex-chewers. The duration of areca nut use and the number of portions of areca nut chewed each day were also recorded.

To investigate whether demographic and socio-economic factors (occupation and education) differed between the areca nut chewers and the non-chewers, these data were also collected. Occupation was classified as in the study by Hashibe et al. [14]. Data on biological factors associated with the risk of Type 2 diabetes were also collected, including systolic blood pressure, diastolic blood pressure, BMI, total cholesterol, triglyceride, blood urea nitrogen, serum creatinine, uric acid and central obesity (as waist circumference). The univariate distribution of these factors is summarised in Table 1.

**Statistical analysis.** The prevalences of hyperglycaemia and Type 2 diabetes in chewers and non-chewers were compared using the chi square test. Subjects were classified into five groups according to age (<40, 40–49, 50–59, 60–69 and  $\geq 70$  years). Multiple logistic regression modelling was then used to investigate whether areca nut chewing had an independent effect on the risk of hyperglycaemia or of Type 2 diabetes after adjustment for age, risk factors associated with Type 2 diabetes and socio-economic status. The models used were chosen to minimise residual confounding [15, 16]. Continuous confounders were adjusted either as linear terms or by quintile distribution. The choice of which adjustment to use for each continuous variable was determined by testing for departure from linearity between two models, one including dummy variables and the other assuming linearity for the variables of interest using likelihood ratio testing (LRT). When the result of the LRT was significant, the confounder in question was included after stratification into quintiles, otherwise the linear data for the confounder was used. Trend analysis, based on LRT, was also used to define the models for the assessment of dose-response relationships of areca nut use with respect to the duration and the quantity or intensity (duration  $\times$  quantity) of areca nut chewed [17]. A *p* value of less than 0.05 was considered significant.

## Results

Table 1 shows the distribution of demographic and biochemical data according to areca nut use. Table 2 shows the prevalence of areca nut use according to age. The average overall usage rate was 14.4%. Table 3 shows that the unadjusted prevalence rate for hyperglycaemia was 9.3% in chewers and 10.7% in non-chewers ( $p=0.046$ ). However, when divided into five groups according to age (see Subjects and methods section), chewers aged 50–69 years had statistically higher prevalence rates for hyperglycaemia than non-chewers (age 50–59 years  $p=0.032$ , age 60–69 years  $p=0.002$ ). As regards subjects aged less than 50 years, the prevalence rates for hyperglycaemia in chewers were still higher than those in non-chewers. This difference was not statistically significant for the group

**Table 1.** Univariate distribution of demographic and biochemical variables categorized by areca nut chewing in men (KCIS programme, 1999–2001)

Variable	Areca nut chewing		
	Current or ex-chewers (n=2120)	Non-chewers (n=12,696)	Total (n=14,816)
<b>Demographic variables</b>			
Age (years)	45.1±10.3	55.6±13.9 <sup>a</sup>	54.1±14.0
Physical activity (% yes)	82.3	86.9 <sup>b</sup>	86.2
<b>Education (%)</b>			
College or above	9.8	20.2 <sup>b</sup>	18.7
Senior high school	41.4	26.8	28.9
Junior high school or below	48.8	53.0	52.4
<b>Occupation (%)</b>			
None	21.8	37.6 <sup>b</sup>	35.3
Retired	1.7	6.1	5.5
Manual	35.3	19.5	21.8
Teacher, office holder, military	11.2	12.4	12.2
Business, professional	19.6	17.2	17.5
Service trade, others	10.4	7.3	7.7
<b>Biochemical variables</b>			
BMI (kg/m <sup>2</sup> )	25.5±3.6	24.9±3.5 <sup>a</sup>	25.0±3.5
Waist circumference (cm)	85.7±9.6	85.4±9.3	85.4±9.4
Systolic BP (mm Hg)	128.2±20.0	131.4±20.9 <sup>a</sup>	131.0±20.8
Diastolic BP (mm Hg)	83.0±11.9	82.5±11.6	82.6±11.6
Total cholesterol (mmol/l)	5.02±1.03	5.05±1.09	5.05±1.08
Triglyceride (mmol/l)	1.99±2.13	1.50±1.21 <sup>a</sup>	1.57±1.39
BUN (mmol/l)	0.54±0.16	0.59±0.20 <sup>a</sup>	0.58±0.19
Creatinine (µmol/l)	95.28±28.35	99.06±37.30 <sup>a</sup>	98.52±36.17
Uric acid (mmol/l)	0.38±0.10	0.38±0.10	0.38±0.10

Data are means ± SD or percentages. <sup>a</sup> A *p* value of less than 0.05 for the two sample independent *t* tests was considered significant for continuous variables; <sup>b</sup> a *p* value of less than 0.05 for the chi square tests was considered significant for categorical variables

**Table 2.** Prevalence of areca nut chewing with age in men (KCIS programme, 1999–2001)

Age (years)	n <sup>a</sup>	Areca nut chewing						<i>p</i> value for $\chi^2$ test
		Current chewers		Ex-chewers		Non-chewers		
		<i>n</i>	%	<i>n</i>	%	<i>n</i>	%	
<40	2707	398	14.7	331	12.2	1978	73.1	<0.0001
40–49	3737	421	11.3	365	9.8	2951	78.9	
50–59	2522	205	8.1	161	6.4	2156	85.5	
60–69	3031	105	3.5	91	3.0	2835	93.5	
≥70	2819	19	0.7	24	0.9	2776	98.4	
Total	14816	1148	7.8	972	6.6	12696	85.6	

<sup>a</sup> See Subjects and methods section for details of population screened

aged 40–49 years ( $p=0.18$ ) and of borderline statistical significance in subjects younger than 40 years of age ( $p=0.09$ ). In subjects aged 70 years or older, non-chewers had only a marginally higher prevalence rate than chewers. These findings suggested that age was a confounding factor and should be adjusted for. The overall age-adjusted prevalence of hyperglycaemia was 11.4% in chewers and 8.7% in non-chewers

( $p<0.0001$ ). The age at which the prevalence of hyperglycaemia rose above 15% was younger in chewers than in non-chewers. Similar findings were noted for Type 2 diabetes (Table 3).

After adjusting for age, socio-economic status, and other biological factors, the adjusted odds ratios [ORs] for the association between areca nut use and the risk of hyperglycaemia and Type 2 diabetes were 1.19

Table 3. Prevalence of hyperglycaemia and Type 2 diabetes in men stratified by age (KCIS programme, 1999–2001)

Age	Total				Hyperglycaemia				Type 2 diabetes				
	Current or ex-chewers		Non-chewers		Current or ex-chewers		Non-chewers		Current or ex-chewers		Non-chewers		p value for $\chi^2$ test
	n	Prevalence (%)	n	Prevalence (%)	n	Prevalence (%)	n	Prevalence (%)	n	Prevalence (%)	n	Prevalence (%)	
<40	729	3.6	47	2.4	20	2.7	33	1.7	0.090				
40–49	786	7.4	179	6.1	43	5.5	146	4.9	0.179				
50–59	366	16.9	62	12.8	56	15.3	235	10.9	0.032				
60–69	196	23.0	421	14.9	45	23.0	402	14.2	0.002				
≥70	43	14.0	439	15.8	6	14.0	469	16.9	0.740				
Total	2120	9.3	1362	10.7	170	8.0	1285	10.1	0.046				
Age-adjusted prevalence <sup>a</sup>		11.4	8.7			10.3			<0.0001				

Hyperglycaemia was defined as a fasting plasma glucose concentration  $\geq 6.1$  mmol/l. <sup>a</sup> Standardised to the world population (Segi's standard [22])

Table 4. Adjusted odds ratios for significant factors of hyperglycaemia or Type 2 diabetes in areca-nut-chewing men using multiple logistic regression models (KCIS programme, 1999–2001)

Model	Hyperglycaemia		Type 2 diabetes	
	OR	95% CI	OR	95% CI
Adjusted for age <sup>a</sup>	1.39	1.17–1.64	1.41	1.18–1.68
Adjusted for age and other confounders	1.19 <sup>b</sup>	0.97–1.45	1.29 <sup>c</sup>	1.04–1.60

Areca nut chewers (n=2120) vs non-chewers (n=12,696). Hyperglycaemia was defined as a fasting plasma glucose concentration  $\geq 6.1$  mmol/l. <sup>a</sup> Age was divided into five groups: <40, 40–49, 50–59, 60–69 and  $\geq 70$  years; <sup>b</sup> other confounders included obesity (yes/no), hypertension (yes/no), physical activity (high/low), education and occupation categorised as in Table 1, total cholesterol (quintiles), triglyceride (quintiles), creatinine (quintiles), uric acid (quintiles), BMI (quintiles), and log-transformed BUN (linear term); <sup>c</sup> confounders and their characteristics were similar to those in footnote b except total cholesterol was adjusted as a linear term after log-transformation of values

(95% CI 0.97–1.45) and 1.29 (95% CI 1.04–1.60) respectively (Table 4).

After controlling for relevant factors, significant dose–response relationships were noted with respect to the duration of chewing and quantity of nuts chewed (Table 5). All trend tests were statistically significant ( $p < 0.05$ ). Compared with non-chewers, the risk of Type 2 diabetes was 1.41 times higher (95% CI 1.08–1.86) in those who had chewed areca nut for more than 20 years and 2.02 times higher (95% CI 1.31–3.09) in those who had chewed more than 20 pieces of areca nut per day. Similar findings, though of smaller magnitude, were noted for hyperglycaemia. Table 5 also shows the combined effect of usage rates and duration of use expressed as intensity (duration  $\times$  quantity). Trend tests for the intensity values divided into quartiles were statistically significant for hyperglycaemia ( $p = 0.01$ ) and Type 2 diabetes ( $p < 0.01$ ).

### Discussion

The present study used a population-based design to investigate the association between the use of areca nut chews (the type prepared by combining areca nut, *Piper betle* vine leaf and lime paste) and hyperglycaemia and Type 2 diabetes. Three major findings of this study are in agreement with previous experimental work showing that feeding areca nut to young adult mice can induce permanent glucose intolerance in a significant proportion of animals [9].

Firstly, the associations between areca nut use and the risk of hyperglycaemia or Type 2 diabetes remained after adjustment for age, socio-economic status and potentially confounding lifestyle and biological

1258 B

**Table 5.** Multiple logistic regression models on the risk factors for the development of hyperglycaemia and Type 2 diabetes in men (KCIS programme, 1999–2001)

Variables	Hyperglycaemia			Type 2 diabetes		
	OR	95% CI	Test for trend	OR	95% CI	Test for trend
<b>Duration of chewing areca nuts</b>						
No chewing	1.00	–	$\chi_{(1)}^2=5.62$ $p=0.018$	1.00	–	$\chi_{(1)}^2=6.63$ $p=0.010$
<10 years	0.74	0.39–1.40		0.75	0.37–1.50	
10–19 years	1.26	0.87–1.81		1.32	0.89–1.94	
≥20 years	1.35	1.05–1.75		1.41	1.08–1.86	
<b>Quantity of areca nuts chewed (per day)</b>						
No chewing	1.00	–	$\chi_{(1)}^2=4.05$ $p=0.044$	1.00	–	$\chi_{(1)}^2=9.56$ $p=0.002$
<10 pieces	1.18	0.89–1.58		1.14	0.83–1.56	
10–19 pieces	1.20	0.80–1.78		1.30	0.85–1.98	
≥20 pieces	1.47	0.95–2.27		2.02	1.31–3.09	
<b>Intensity of chewing (quantity × duration)<sup>b</sup></b>						
No chewing	1.00	–	$\chi_{(1)}^2=6.46$ $p=0.010$	1.00	–	$\chi_{(1)}^2=9.47$ $p=0.002$
<1.3	1.01	0.62–1.66		1.08	0.64–1.80	
1.3–3.5	1.04	0.67–1.62		1.13	0.71–1.80	
3.5–9.3	1.25	0.84–1.85		1.16	0.75–1.80	
≥9.3	1.62	1.14–2.31		1.93	1.35–2.77	

Hyperglycaemia was defined as a fasting plasma glucose level  $\geq 6.1$  mmol/l. The results for 14 816 subjects were analysed. <sup>a</sup> The confounders adjusted for in this model are identical to those listed in Table 4; <sup>b</sup> values are expressed as  $\times 10^4$  piece-days

cal factors. This suggests an independent effect of this particular habit. Our findings, together with more recent population survey data from Papua New Guinea, strengthen the argument for the diabetogenicity of areca nut use [18].

In the present study, the younger age of onset of Type 2 diabetes in chewers compared with non-chewers is consistent with the fact that a study conducted in Coventry (UK) revealed that South Asian subjects developed Type 2 diabetes at an earlier age than the European subjects [19]. Furthermore, these individuals required supplemental hypoglycaemic medication more frequently and at a younger age than the Europeans [19]. The younger age of onset observed in our study also paralleled the increased prevalence of the areca nut habit in younger people, reflecting the comparatively recent uptake of the habit over the last 40 years.

The finding of significant dose–response relationships between areca nut use (both in terms of quantity and duration) and hyperglycaemia and Type 2 diabetes suggests that an active arecal agent is directly toxic to beta cells. It is possible that the diabetogenicity of arecal chews might be due to the lime paste used rather than the areca nut. However, there have been no reports to date to suggest that lime paste is either diabetogenic or carcinogenic, though it appears to have a local inflammatory effect in the mouth [20]. In addition, the hyperglycaemia reported experimentally in mice followed the feeding of areca nut without other chew components [9].

In contrast with a previous study conducted in the UK [21], significant direct associations were observed between areca nut use and clinically damaging increases in glycaemia. This discrepancy may reflect the much larger population examined in the present study. Alternatively, it may be due to the fact that the Bangladeshi Asians who took part in the UK study were from communities that have chewed betel-quids (areca nut) for thousands of years [21], whereas the current levels of areca nut use in Taiwanese men have only been reached over the last 40 years. In view of the degree of inheritability of increased glycaemia (with islet damage) that has been demonstrated experimentally in mice fed with areca nuts, the authors of the UK study speculated that the failure to find direct associations in areca-using communities where the habit was long standing may reflect confounding by the similar inheritability of diabetogenic effects in man. Furthermore, it was postulated that any association of environmental exposure to diabetogenic nitroso-compounds with diabetes would be more easily detected in populations where this particular risk factor had only recently been introduced [21]. Thus, the relationships found between Type 2 diabetes and arecal use in the present study are particularly pertinent, since the recent uptake of areca nut chewing by this population has provided a unique opportunity to test the postulated diabetogenicity of this habit in man.

In conclusion, we have demonstrated an association between areca nut chewing and Type 2 diabetes using a population-based study in a community in which the habit is of recent origin.

1257 B

**Acknowledgements.** We are indebted to Y.-D. Chen, P.-E. Wang, T.-T. Wang, Y.-L. Shih, H.-L. Kuo, H.-C. Lee, S.-Y. Hu, C.-L. Wu, Y.-F. Huang, H.-C. Chen and M.-S. Chung from the Health Bureau of Keelung City who were involved in organising and overseeing the KCIS programme, and to C.-H. Chen and B.V. North from the Chang-Gung Memorial Hospital of Keelung for advice on the reporting of the statistical methodology.

## References

- Ko YC, Chiang TA, Chang SJ, Hsieh SF (1992) Prevalence of betel quid chewing habit in Taiwan and related sociodemographic factors. *J Oral Pathol Med* 21:261-264
- Yang YH, Lee HY, Tung S, Shieh TY (2001) Epidemiological survey of oral submucous fibrosis and leukoplakia in aborigines of Taiwan. *J Oral Pathol Med* 30:213-219
- International Agency for Research on Cancer (1985) IARC monographs on the evaluation of carcinogenic risk of chemicals to humans, vol. 37. Tobacco habits other than smoking: betel-quid and areca nut chewing; and some related nitrosamines. International Agency for Research on Cancer, Lyon, pp 141-202
- Ko YC, Huang YL, Lee CH, Chen MJ, Lin LM, Tsai CC (1995) Betel quid chewing, cigarette smoking and alcohol consumption related to oral cancer in Taiwan. *J Oral Pathol Med* 24:450-453
- Sun CA, Wu DM, Lin CC et al. (2003) Incidence and cofactors of hepatitis C virus-related hepatocellular carcinoma: a prospective study of 12,008 men in Taiwan. *Am J Epidemiol* 157:674-682
- Tsai JF, Chuang LY, Jeng JE et al. (2001) Betel quid chewing as a risk factor for hepatocellular carcinoma: a case-control study. *Br J Cancer* 84:709-713
- Wu MT, Lee YC, Chen CJ et al. (2001) Risk of betel chewing for oesophageal cancer in Taiwan. *Br J Cancer* 85:658-660
- Jeng JH, Chang MC, Hahn LJ (2001) Role of areca nut in betel quid-associated chemical carcinogenesis: current awareness and future perspectives. *Oral Oncol* 37:477-492
- Boucher BJ, Ewen SWB, Stowers JM (1994) Betel nut (*Areca catechu*) consumption and the induction of glucose intolerance in adult CDI mice and in their F1 and F2 offspring. *Diabetologia* 37:49-55
- Boucher BJ, Mannan N (2002) Metabolic effects of the consumption of *Areca catechu*. *Addict Biol* 7:103-110
- Chen KT, Chen CJ, Gregg EW, Engelgau MM, Narayan KM (2001) Prevalence of Type 2 diabetes mellitus in Taiwan: ethnic variation and risk factors. *Diabetes Res Clin Pract* 51:59-66
- Chen THH, Chiu YH, Luh DL et al. (2004) Community-based multiple screening model: design, implementation, and analysis of 42,387 participants. *Cancer* 100:1734-1743
- American Diabetes Association (1999) American Diabetes Association: clinical practice recommendations 1999. *Diabetes Care* 22 [Suppl 1]:S1-S114
- Hashibe M, Jacobsen BJ, Thomas G et al. (2003) Socioeconomic status, lifestyle factors and oral premalignant lesions. *Oral Oncol* 39:664-671
- Austin PC, Brunner LJ (2004) Inflation of the type I error rate when a continuous confounding variable is categorized in logistic regression analyses. *Stat Med* 23:1159-1178
- Becher H (1992) The concept of residual confounding in regression models and some applications. *Stat Med* 11:1147-1158
- Clayton D, Hill M (1993) Statistical models in epidemiology. Oxford University Press, Oxford
- Benjamin AL (2001) Community screening for diabetes in the National Capital District, Papua New Guinea: is betel-nut chewing a risk factor for diabetes? *P N G Med J* 44:101-107
- Simmons D, Powell MJ (1993) Metabolic and clinical characteristics of south Asians and Europeans in Coventry. *Diabet Med* 10:751-758
- Lee MJ, Hsu JD, Lin CL, Lin MH, Yuan SC, Wang CJ (2002) Induction of epidermal proliferation and expressions of PKC and NF-kappaB by betel quid extracts in mouse: the role of lime-piper additives in betel quid. *Chem Biol Interact* 140:35-48
- Mannan N, Boucher BJ, Evans SJW (2000) Increased waist size and weight in relation to consumption of *Areca catechu* (betel-nut): a risk factor for increased glycaemia in Asians in east London. *Br J Nutr* 83:267-275
- Waterhouse J, Muri CS, Correa P, Powell J (1976) Cancer incidence in five continents, Vol 3. IARC Scientific Publications, Lyon

# Betelnut chewing: a contributing factor to the poor glycaemic control in diabetic patients attending Port Moresby General Hospital, Papua New Guinea.

Benjamin AL, Margis D.

School of Medicine and Health Sciences, University of Papua New Guinea, Port Moresby.

## Abstract

This descriptive study was conducted in the Diabetes Clinic of the Port Moresby General Hospital for 6 months, from July to December 2002. The aim was to document the usage and effects of betelnut chewing in diabetic patients. 210 patients were randomly selected from the list of patients in the appointment book, using a random number table. Betelnut chewing caused hyperglycaemia and diabetes mellitus in animal models. It was significantly associated with high fasting capillary blood glucose and was an independent risk factor for type 2 diabetes mellitus. In this study, the majority of patients with diabetes were in the older age group ( $> \alpha = 45$  years) and many of them were overweight or obese. The majority of patients had lived in the city of Port Moresby for many years before their diagnosis. 74% of diabetic patients chewed betelnut before their diagnosis and had continued the habit while undergoing treatment for diabetes. The majority (80%) of patients had poor glycaemic control as indicated by the high mean of their most recent blood glucose, which was 13.0 mmol/l in male and 13.1 mmol/l in female patients; these levels were not much lower than those at diagnosis. The mean follow-up of patients in the clinic was 6.2 years. On the balance of evidence, betelnut is a contributing factor to the poor glycaemic control in diabetic patients attending Port Moresby General Hospital.

1259  
2 8

## The milk-alkali syndrome caused by betelnuts in oyster shell paste.

Wu KD, Chuang RB, Wu FL, Hsu WA, Jan IS, Tsai KS.

Department of Laboratory Medicine, National Taiwan University Hospital, Taipei, Taiwan.

### **Abstract**

**BACKGROUND:** The carcinogenic effect of betelnut chewing leading to oral cancer is well known. Betelnut chewing may also affect the autonomic nervous system. In this report, we present another potential hazard of betelnuts, milk-alkali syndrome.

**CASE REPORT:** Two patients who had chewed a large quantity of betelnuts developed hypercalcemia, metabolic alkalosis, and renal insufficiency. They ingested a large amount of calcium carbonate from a local special paste used for betelnut preparation, the main ingredient of which is ground oyster shell. The symptoms and metabolic abnormalities disappeared promptly after abstinence from betelnut chewing and administration of saline solution. Improvement of renal function was observed in both patients. Analysis of the calcium content of the paste suggested that the patients might have ingested 9 g and 6 g of calcium carbonate per day, respectively.

**CONCLUSION:** This is the first report of milk-alkali syndrome not caused iatrogenically, but by recreational usage of oyster shell preparations of betelnuts.

# JCEM

THE JOURNAL  
OF CLINICAL  
ENDOCRINOLOGY  
& METABOLISM

## Vitamin D Metabolism in Peripheral Blood Mononuclear Cells Is Influenced by Chewing "Betel Nut" (Areca catechu) and Vitamin D Status

William B. Ogunkolade, Barbara J. Boucher, Stephen-A. Bustin, Jacky M. Burrin, Kate Noonan, Nasima Mannan and Graham A. Hitman

J. Clin. Endocrinol. Metab. 2006 91:2612-2617 originally published online May 2, 2006; , doi: 10.1210/jc.2005-2750

To subscribe to *Journal of Clinical Endocrinology & Metabolism* or any of the other journals published by The Endocrine Society please go to: <http://jcem.endojournals.org/subscriptions/>

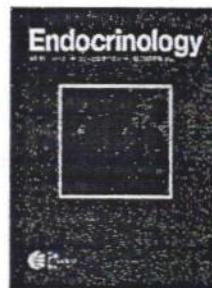
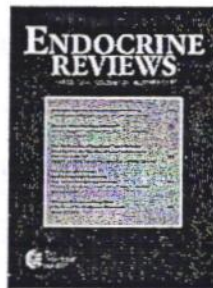
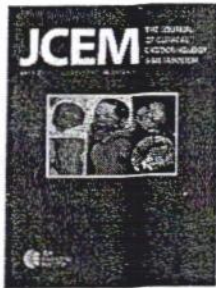

Copyright © The Endocrine Society. All rights reserved. Print ISSN: 0021-972X. Online

1261 B

# Vitamin D Metabolism in Peripheral Blood Mononuclear Cells Is Influenced by Chewing "Betel Nut" (*Areca catechu*) and Vitamin D Status

William B. Ogunkolade,\* Barbara J. Boucher,\* Stephen A. Bustin, Jacky M. Burrin, Kate Noonan, Nasima Mannan, and Graham A. Hitman

Centers for Diabetes and Metabolic Medicine and Academic Surgery, Institute of Cell and Molecular Science (W.B.O., B.J.B., S.A.B., N.M., G.A.H.), and Clinical and Molecular Endocrinology, William Harvey Institute (J.M.B.), Queen Mary's School of Medicine and Dentistry, University of London and Department of Clinical Chemistry (K.N.), Barts and The London National Health Service Trust, Royal London Hospital, London E1 1BB, United Kingdom

**Context:** Vitamin D deficiency, common in South Asians, is a risk factor for metabolic syndrome, type 2 diabetes, and ischemic heart disease. Vitamin D receptor (VDR) activation depends on activated vitamin D [1,25-dihydroxyvitamin D (1,25(OH)<sub>2</sub>D)] concentration, reflecting opposing actions of 25-hydroxyvitamin D-1 $\alpha$ -hydroxylase [1- $\alpha$ (OH)ase] for formation and 25(OH)D-24-hydroxylase [24(OH)ase] for catabolism. We previously reported that circulating 1,25(OH)<sub>2</sub>D contributed to determination of VDR-protein levels and VDR genotype was a determinant of both VDR mRNA and VDR-protein in South Asians.

**Objective:** We hypothesized that chewing betel nut, an addictive habit common throughout South Asian communities, contributes to hypovitaminosis-D by modulating the enzymes regulating circulating 1,25(OH)<sub>2</sub>D concentration.

**Design:** Peripheral blood mononuclear cell (PBMC) 1- $\alpha$ (OH)ase and 24(OH)ase mRNA concentrations were measured and examined in relation to cross-sectional data on the vitamin-D axis, diet, smoking,

and betel usage, including PBMC VDR-RNA and VDR-protein content in a pilot study of 33 healthy British Bangladeshis.

**Results:** PBMC 24(OH)ase mRNA correlated positively and serum 1,25(OH)<sub>2</sub>D negatively with betel quids per day ( $r = 0.49$ ,  $P = 0.006$  and  $r = -0.486$ ,  $P = 0.006$ , respectively). Independent determinants for 24(OH)ase included betel quids per day ( $P < 0.0001$ ) and serum 25-OHD ( $P = 0.024$ ). Independent determinants for serum 1,25(OH)<sub>2</sub>D were gender, smoking, and betel quids per day. PBMC 1- $\alpha$ (OH)ase mRNA correlated inversely with VDR mRNA ( $r = -0.44$ ;  $P = 0.013$ ); its independent determinants were serum 1,25(OH)<sub>2</sub>D and VDR *TaqI* and *BsmI* polymorphisms ( $P = 0.03-0.0001$ ).

**Conclusions:** Betel chewing is a more powerful independent determinant of increased 24(OH)ase expression and of decreased serum calcitriol than serum 25-OHD, supporting the hypothesis that this habit could aggravate the effects of vitamin-D deficiency. (*J Clin Endocrinol Metab* 91: 2612-2617, 2006)

VITAMIN D, WHETHER DIETARY or formed in the skin by UV radiation, is hydroxylated to 25-hydroxyvitamin D (25-OHD) in the liver and, once bound to circulating vitamin D binding proteins, has a half-life of several weeks (1, 2). Serum levels of 25-OHD are accepted as reflecting vitamin D "status" (3, 4). Activation of 25-OHD by 25-hydroxyvitamin D-1 $\alpha$ -hydroxylase [1- $\alpha$ (OH)ase] to form hormonal vitamin D [1,25-dihydroxyvitamin D; calcitriol (1,25(OH)<sub>2</sub>D)] was first thought to take place solely in the kidney but is now recognized in many extrarenal tissues (5). Tissues such as circulating monocytes [peripheral blood mononuclear cells (PBMCs)], pancreatic islets, vascular wall, brain, colon, and breast express both the 1- $\alpha$ (OH)ase enzyme and the vitamin D receptor (VDR) and, in addition, the enzyme 25(OH)D-24-hydroxylase [24(OH)ase] that inactivates

1,25(OH)<sub>2</sub>D and probably also 25-OHD (5, 6). Circulating PTH contributes to the up-regulation of renal 1- $\alpha$ (OH)ase activity, and its secretion itself is suppressed by 1,25(OH)<sub>2</sub>D, providing a feedback mechanism, reducing the risk of vitamin D toxicity (1, 2). However, it is not believed that PTH affects 1- $\alpha$ (OH)ase expression directly in other tissues such as the PBMC, even though macrophages produce hormonally active vitamin D. Furthermore, locally produced 1,25(OH)<sub>2</sub>D will recruit monocytes into the differentiation process, leading to increased macrophage production, as demonstrated in monocyte culture (7), although the mechanisms regulating these extrarenal processes are yet to be understood fully (8).

The "classical" actions of vitamin D ensure the maintenance of calcium and phosphate homeostasis and of adequate bone ossification (1, 2), but the "nonclassical" actions of vitamin D affect many other tissues in humans. These include pancreatic islet insulin secretion, insulin resistance, the immune system, and the induction of cellular differentiation (9-14). Such nonclassical actions may explain why vitamin D deficiency is linked to increased cancer risks in many organs where the VDR is expressed (e.g. breast, colon, ovary, and prostate) as well as associations with other conditions (13, 14).

First Published Online May 2, 2006

\* W.B.O. and B.J.B. are joint first authors.

Abbreviations: 1- $\alpha$ (OH)ase, 25-Hydroxyvitamin D-1 $\alpha$ -hydroxylase; 24(OH)ase, 25(OH)D-24-hydroxylase; 25-OHD, 25-hydroxyvitamin D; 1,25(OH)<sub>2</sub>D, 1,25-dihydroxyvitamin D (calcitriol); PBMC, peripheral blood mononuclear cell; VDR, vitamin D receptor.

JCEM is published monthly by The Endocrine Society (<http://www.endo-society.org>), the foremost professional society serving the endocrine community.

Vitamin D deficiency is also associated with increased risk, and severity, of chronic inflammatory disorders including tuberculosis and leprosy (15, 16) and, in early life, with increases in autoimmune disorders such as type 1 diabetes in childhood and early adult life (17–20). These phenomena may reflect reductions in the monocyte activation and differentiation into macrophages and dendritic cells induced by activated vitamin D, as found *in vitro* (6–8). During this differentiation VDR expression falls, whereas that of the 1- $\alpha$ (OH)ase increases (7), suggesting that VDR expression in healthy PBMCs should be inversely related to expression of the 1- $\alpha$ (OH)ase when examined in subjects of varying vitamin D status.

Vitamin D deficiency remains common in Indian Asian immigrants and their descendants, but is also seen in healthy South Asians living in sunny climates (9–11, 21, 22). Most studies attribute the high prevalence of vitamin D deficiency to cultural and dietary habits. In addition, an alteration in vitamin D metabolism has been postulated recently in South Asians after the finding of increased 24(OH)ase activity in skin fibroblasts in American South Asians compared with American white subjects (23). This increase in 24(OH)ase would be expected to lead to increased catabolism of the active metabolite 1,25(OH)<sub>2</sub>D and perhaps of 25-OHD, worsening the effects of hypovitaminosis D. Failure of British South Asians to respond fully to supplementation (24) may be explained by this finding. We have previously shown, in British South Asians, that circulating levels of calcitriol [hormonal vitamin D; 1,25(OH)<sub>2</sub>D] contribute to the determination of VDR protein levels *in vivo* and, in addition, that VDR genotype is a significant determinant of both VDR mRNA and protein levels in PBMCs (25). Because production of activated vitamin D is increased in vitamin D deficiency (1, 2, 26), it is likely that VDR genotype contributes to the feedback control mechanism determining vitamin D activation. Therefore, we have hypothesized that the clinical effects of this deficiency could be influenced by genetic, environmental, or dietary factors specific to this population.

An obvious candidate is the addictive habit of betel chewing. Nuts of the *Areca catechu* palm are wrapped in leaves of the *Piper betle* vine, usually spread with lime paste, to form quids, or “chews” (sometimes called “pan” or “paan”). In some communities (including our local Bangladeshi population living in East London) tobacco is also added. This is the fourth most common addictive habit worldwide after smoking, caffeine, and alcohol, and is estimated to be used by 600 million people worldwide (27). The effects of betel chewing

on vitamin D metabolism or calcium homeostasis are unknown, although there is one case report of hypercalcemic alkalosis after long-term daily consumption of 40 betel quids (containing lime paste rich in calcium hydroxide) (28). Pilot studies were set up to determine whether *in vivo* expression of 1- $\alpha$ (OH)ase and 24(OH)ase genes relate to VDR gene expression, using circulating PBMCs from healthy subjects, as a reflection of the induction of differentiation of macrophages from monocytes (7). We also aimed to determine whether vitamin D status (serum 25-OHD), circulating PTH, or VDR polymorphisms affect 1- $\alpha$ (OH)ase or 24(OH)ase gene expression in the PBMC or, in particular, whether vitamin D metabolism in the PBMC is affected by dietary habits common in South Asians such as chewing “betel nut” (*Areca catechu*) (27).

## Subjects and Methods

### Subjects

Forty-one healthy British Bangladeshi subjects, aged 31–65 yr, living in East London, free of ongoing illness, and on no long-term medication gave written informed consent to provision of a blood sample for an embedded cross-sectional study of the vitamin D axis during a study of vitamin D insufficiency in relation to risk factors for type 2 diabetes and ischemic heart disease (29, 30). These studies were approved by the appropriate District Ethical Committee. Thirty-six percent of the subjects were men. Data from a previously validated questionnaire were available on smoking, betel nut (paan quid) usage, and the intake of fish (several species of imported freshwater fish that are vitamin D rich, and fish being eaten daily by >40% of subjects; average 5.5 times per week), eggs (averaging 60 U each in the United Kingdom; Boucher, B. J., N. Mannan, and K. Noonan, unpublished data), yogurt (sometimes fortified in the United Kingdom), and margarine (fortified by statute in the United Kingdom) (10, 29). VDR genotype (*Apal*, *BsmI*, *TaqI*, and *FokI*) had also been determined, as previously reported, in this subgroup (30).

### RNA extraction and real-time quantitative RT-PCR analysis

Total cellular RNA was extracted from untreated PBMCs, as for the VDR, as previously reported, from 10<sup>7</sup> PBMCs using the RNeasy mini RNA isolation kit (QIAGEN Inc., Crawley, UK). RNA quality was assessed using RNA LabChips on an Agilent 2100 Bioanalyser (Agilent Technologies, Waldbronn, Germany) and quantified in triplicate, using Ribogreen quantification kits (Molecular Probes, Leiden, The Netherlands). PBMC VDR mRNA and VDR protein levels in these subjects were measured in extracts from 10<sup>7</sup> cells as reported previously (25).

1- $\alpha$ (OH)ase mRNA and 24(OH)ase mRNA were measured by quantitative real-time polymerase chain reaction (qRT-PCR) in PBMCs as follows. Sequence-specific primers and probes (Table 1) were designed using Primer Express (Applied Biosystems, Warrington, UK), and synthesized by Applied Biosystems or Prologo (Paris, France). The TaqMan probe was labeled with a reporter dye (6-carboxy-fluorescein) at the 5'

**TABLE 1.** Formulæ for forward (F) and reverse (R) primers and probes (P) used for the measurement of the expression of the target genes for the two vitamin D metabolic enzymes studied and for the vitamin D receptor

Target	Primers	Test for linearity between threshold cycle and log of starting RNA-copy no. in the assay runs for each gene
1- $\alpha$ (OH)ase-F	GCTATTGGCCGGAGTGGAC	Slope = 3.497
1- $\alpha$ (OH)ase-R	GCCGGGAGAGCTCATAACA	Y intercept = 46.053
1- $\alpha$ (OH)ase-P	CCCAAGAGAGCGTGTGGACACCG	R <sup>2</sup> = 0.9955
24(OH)ase-F	GAgCACTgTTCCTTTgggTAAAg	Slope = 3.4173
24(OH)ase-R	GCTTACgCCgAgTgTACCATT	Y intercept = 47.702
24(OH)ase-P	TCACCCAgAACTgTgCCTTgTCA	R <sup>2</sup> = 0.998
VDR-F	ATCTGCATCGTCTCCCAGAT	Slope = 3.5639x
VDR-R	AGCGGATGTACGTCTGCAGTG	Y intercept = 47.032
VDR-P	TGATTGAGGCCATCCAGACCGC	R <sup>2</sup> = 0.994

1263

end and a quencher dye (6-carboxy-tetramethyl-rhodamine) at the 3' end. qRT-PCR was performed with 50-ng (in duplicate) aliquots of RNA, from the same cells that had previously been used to quantify VDR mRNA and VDR protein levels (25), using an ABI Prism 7700-sequence detector (Applied Biosystems, Warrington, Cheshire, UK), or Stratagene MX4000 (Stratagene, La Jolla, CA), and analyzed with the corresponding manufacturer-supplied software. mRNA copy numbers were determined from a specific standard curve obtained by serially diluting a synthetic single-stranded sense oligonucleotide specifying the 1- $\alpha$ (OH)ase or 24(OH)ase amplicon (31). There was a strong linear relationship between the threshold cycle and the log of the starting RNA-copy number in all runs ( $r > 0.99$ ; Table 1). All serial dilutions were carried out in duplicate. Standard curves in triplicate were repeated twice with duplicate no-template controls included with every RT-PCR run. Copy numbers were normalized relative to total RNA concentration, and the levels were expressed as mRNA copy numbers per microgram of total RNA (32).

### Immunoassays

Serum 25-OHD [ $<20$  ng/ml ( $<50$  nmol/liter) defining vitamin D insufficiency (4)] and 1,25(OH) $_2$ D [normal range for adults 20–46 pg/mol (48–110 pmol/liter)] and serum intact PTH concentration [normal range 430–1070 pg/ml (48–119 pmol/liter)] were measured by immunoassay in single assays (IDS Ltd., Boldon, Tyne and Wear, UK; intraassay coefficient of variation  $< 7\%$ ) as previously reported (29). Information on insulin secretory profiles and glycemia at oral glucose tolerance test within the parent study was also available together with calculated "insulin secretion index" derived from data at 75-g oral glucose tolerance testing (33).

### Statistical analyses

Simple and partial correlation coefficients and variation of means with VDR polymorphisms were examined using parametric or non-parametric tests as appropriate and stepwise multiple regression analysis was carried out (to  $P < 0.05$ ), after normalization of data distribution where necessary, using SPSS version 11. Results are given as mean  $\pm$  SD in the text and tables and as mean  $\pm$  SE in Fig. 1.

## Results

Table 2 shows the main demographic details and data for dietary factors examined in the study subjects. Table 3 shows the mean (SD) and ranges for serum 25-OHD, 1,25(OH) $_2$ D, and for PBMC content of 1- $\alpha$ (OH)ase mRNA and 24(OH)ase mRNA. The data reported for VDR mRNA and VDR-protein

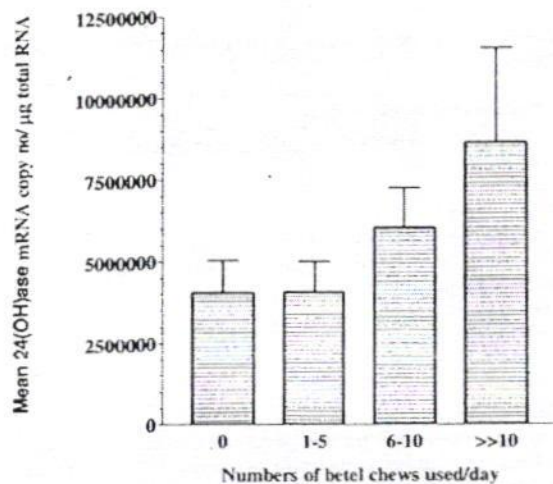

FIG. 1. mRNA expression (copy numbers per microgram of total RNA) of the 24(OH)ase gene in fresh blood mononuclear cells in six nonchewers and in subjects chewing increasing numbers of betel nut quids per day.

TABLE 2. Age, body mass index (BMI), smoking habits, rate of chewing paan (betel nut) quids, percentage of chewers adding chewing tobacco to the quids, and data for the consumption of the major United Kingdom South Asian dietary sources of vitamin D (eggs, imported fresh water fish, and the percentage of subjects using margarine) for the 41 subjects in the embedded cross-sectional study

	Mean (SD)	Range (min-max)
Age (yr)	48.32 (9.903)	31–65
BMI	26.24 (3.93)	17.8–33.2
Cigarette smoking (no./d)	3.36 (7.58)	0–30
% Betel chewers	82.9	
No. of betel chews used per day <sup>a</sup>	4.8 (4.76)	0–22
% Paan chewers using added tobacco	51.2	
Eggs eaten (no./wk)	1.13 (1.49)	0.00–7.0 <sup>d</sup>
Fish eaten (times per week)	5.38 (2.19)	0.25–7.0
% Users of margarine <sup>b</sup>	47.5	

<sup>a</sup> Betel chews are defined as quids containing chopped *Areca catechu* nuts wrapped in *Piper betle* vine leaves.

<sup>b</sup> Percentage of margarine users at approximately 15 g/d as a spread.

in these PBMC preparations (25) are those for the subjects in whom sample volumes were adequate for measurement of PBMC 1- $\alpha$ (OH)ase mRNA ( $n = 33$  of 41) and 24(OH)ase mRNA ( $n = 31$  of 41).

There were more women than men in the study group, but there was no variation in 24(OH)ase expression with gender. In addition, men smoked more cigarettes per day than women, but smoking rates did not vary with rates of betel chewing.

Simple correlation analysis showed that the expression of 1- $\alpha$ (OH)ase mRNA was inversely correlated with that of VDR mRNA ( $n = 33$ ,  $r = -0.44$ ;  $P = 0.013$ ).

The independent determinants of 1- $\alpha$ (OH)ase mRNA expression, by multiple regression analysis (Table 4), were circulating 1,25(OH) $_2$ D together with VDR (*TaqI* and *BsmI*) polymorphisms but not serum PTH or any of the other factors examined. When 24(OH)ase mRNA concentrations were included in this analysis, the independent determinants of 1- $\alpha$ (OH)ase mRNA were the VDR (*TaqI* and *Apal*) polymorphisms ( $P < 0.0001$  and  $0.006$ , respectively) and serum 25-OHD ( $P = 0.048$ ) as well as the PBMC content of 24(OH)ase mRNA ( $P = 0.001$ ), although this was not the best-fit model ( $P$  for the constant  $< 0.0001$ ); because VDR genotype contributes to the determination of VDR message and protein in these subjects (25), this analysis was repeated omitting VDR mRNA content but the findings were not changed; omitting VDR-protein content revealed betel quids per day as the sole determinant of 1- $\alpha$ (OH)ase mRNA expression, and no determinants of 1- $\alpha$ (OH)ase mRNA were identified when both VDR mRNA and VDR-protein concentrations were omitted from the analysis.

The expression level of 24(OH)ase mRNA in PBMCs was higher, although not significantly, in chewers ( $n = 25$ ) than in never-chewers ( $n = 6$ ) [mean(SD) =  $40.5 \times 10^5$  ( $24.3 \times 10^5$ ) compared with  $55.2 \times 10^5$  ( $43.2 \times 10^5$ );  $P = 0.43$ ], but was directly correlated with the number of paan (betel) quids eaten daily [ $r = 0.49$ ;  $P = 0.006$  and  $0.71$ ,  $P < 0.0001$  by partial correlation, allowing for serum 25-OHD and 1,25(OH) $_2$ D] as illustrated by the raw data in Fig. 1. Serum 25-OHD was not

1264

**TABLE 3.** Concentrations of 25-OHD and 1,25(OH)<sub>2</sub>D in serum and PBMC concentrations of VDR mRNA, VDR protein, 1-α(OH)ase mRNA, and 24(OH)ase mRNA in subjects included in the present study

	Mean (sd)	Range (min-max)
25(OH)D (ng/ml) <sup>a</sup> (nmol/liter)	9.3 (4.4) (n = 39)	1.6-25.8
1,25(OH) <sub>2</sub> D (pg/ml) <sup>a</sup> (pmol/liter)	23.2 (10.9)	4-64.5
Intact PTH (pg/ml) (pmol/liter)	33.4 (11.3) (n = 34)	38.8-150.1
VDR mRNA (copy no./μg total RNA) <sup>a</sup>	80.1 (27.2)	93-360.0
VDR protein (μg/mg of total extract protein) <sup>a</sup>	355 (175) (n = 39)	130-1040
1-α(OH)ase mRNA (copy no./μg total RNA)	39.0 (19.2)	14.2-114
25(OH)D-24-OHase mRNA (copy no./μg total RNA)	1.1403 × 10 <sup>5</sup> (0.44 × 10 <sup>5</sup> )	0.31 × 10 <sup>5</sup> to 2.43 × 10 <sup>5</sup>
	17.49 (9.63) (n = 38)	1.0-38.73
	1.157 (0.34) × 10 <sup>6</sup> (n = 33)	5.89 × 10 <sup>5</sup> to 1.1917 × 10 <sup>6</sup>
	5.22 (4.02) × 10 <sup>6</sup> (n = 31) <sup>a</sup>	0.99 × 10 <sup>6</sup> to 15.9 × 10 <sup>6</sup>

The number of samples (n) available for the study is given wherever less than 41 (some samples were inadequate in volume).

<sup>a</sup> Data previously published (25) but reanalyzed for the subgroup of subjects of the present study.

related to betel quids per day. Serum 1,25(OH)<sub>2</sub>D correlated negatively with the number of paan (betel) quids eaten daily ( $r = -0.43$ ,  $P = 0.006$ ; Fig. 2).

The independent determinants for 24(OH)ase mRNA (Table 4) included betel quids per day and serum 25-OHD when 1-α(OH)ase was included in analysis, but betel quids per day alone when 1-α(OH)ase was excluded. Betel quids per day was a less powerful determinant of serum 1,25(OH)<sub>2</sub>D than gender or cigarettes smoked per day (data not shown); the latter was inversely correlated to serum PTH on Spearman ranking ( $r = -0.28$ ,  $P < 0.0001$  for the parent group and  $r = -0.3$ ,  $P = 0.049$  in the current study subgroup). The inclusion of data on the addition of chewing tobacco to paan quids did not affect the significance of any of the findings.

### Discussion

We have found a direct correlation between 25-OHD-24(OH)ase expression and the rates of use of betel quid (paan) chews containing *Areca catechu* nut in the present cross-sectional study. The finding of dose-effects for this relationship and that the relationship is independent of other factors known to regulate 24(OH)ase expression suggests that, despite the cross-sectional nature of the study, betel chewing may explain the increases in tissue activity of

24(OH)ase, the rate-limiting enzyme for degradation of 1,25(OH)<sub>2</sub>D, reported in South Asians, even though they were vitamin D deficient (23). This is a surprising finding because induction of the 24(OH)ase gene in the presence of increased vitamin D availability is a recognized part of the feedback mechanisms preventing vitamin D intoxication. This enzyme is catabolic for both activated vitamin D and its immediate precursor 25-OHD. The biological effects of vitamin D inadequacy could, therefore, be aggravated by betel chewing in vitamin D deficiency.

Compared with white Caucasians, South Asians in the West and Northern world have a higher prevalence of vitamin D deficiency than white Caucasians (10, 12, 15, 23). This deficiency has been implicated as a risk factor for various diseases including diabetes, ischemic heart disease, and tuberculosis. We have previously shown, in the subjects of the present study, that the circulating level of activated vitamin D [1,25(OH)<sub>2</sub>D] is a predictor of VDR protein in the PBMC and that VDR mRNA and VDR protein levels in circulating PBMCs also predict variations in insulin secretion index, *in vivo*, as assessed at oral glucose tolerance test (25, 30). We now observe that 1-α(OH)ase mRNA concentration in PBMCs is inversely correlated to that of VDR mRNA, *in vivo*. Because PBMC differentiation *in vitro* has been shown

**TABLE 4.** Multiple regression analysis for the determinants of gene expression for the enzymes 25(OH)D-1-α-hydroxylase (activating vitamin D) and 25(OH)D-24-hydroxylase [catabolizing 1,25(OH)<sub>2</sub>D] in PBMC

Measurement	Independent determinants <sup>a</sup>	P value
PBMC 1-α(OH)ase mRNA concentration	(Best fit model. $R^2 = 0.61$ ( $P < 0.002$ ) $P$ for constant = 0.051)	
	VDR ( <i>Taq1</i> ); ( $\beta = 0.85$ )	<0.0001
	VDR ( <i>Bsm1</i> ); ( $\beta = 0.46$ )	0.031
	Serum 1,25(OH) <sub>2</sub> D ( $\beta = -0.46$ )	0.016
PBMC 24(OH)ase mRNA concentration	With paan (betel quids per day; unadjusted ( $R^2 = 0.24$ ))	0.006
	(Best fit model. $R^2 = 0.64$ ( $P < 0.0001$ ) $P$ for constant = 0.98)	
	Adjusted for other variables	
	Paan (betel) quids per day ( $\beta = 0.63$ )	<0.0001
	Serum 25-OHD ( $\beta = 0.44$ )	0.024
	Margarine use ( $\beta = -0.29$ )	<0.002
	1α(OH)ase ( $\beta = 0.33$ )	0.004
VDR <i>Taq1</i> ( $\beta = -0.24$ )	0.031	

The variables examined as possible determinants were serum homocysteine; creatinine; fasting proinsulin to insulin ratio; folate; insulin secretory capacity; consumption of eggs, fish, yogurt, margarine, and cigarettes; age, gender, body build, glycemia; VDR (*Apal*, *Bsm1*, *Taq1*, and *Fok1*) genotype; serum PTH, 25-OHD, and 1,25(OH)<sub>2</sub>D. Note that VDR (*Apal* and *Fok1*) genotype and serum 25-OHD were excluded as determinants of PBMC 1-α(OH)ase mRNA measurements, and that serum 1,25(OH)<sub>2</sub>D, VDR genotype (*Apal*, *Taq1*, *Bsm1*, and *Fok1*) and PBMC 1-α(OH)ase mRNA concentrations were excluded as determinants of PBMC 24(OH)ase mRNA concentration, by multiple regression analysis.

<sup>a</sup> Independent determinants were identified by multiple regression analysis ( $P < 0.05$ ).  $\beta$  is the standardized correlation coefficient calculated for the relation of each stated determinant to the measurement of interest after adjustment for all other related factors (using SPSS version 11).

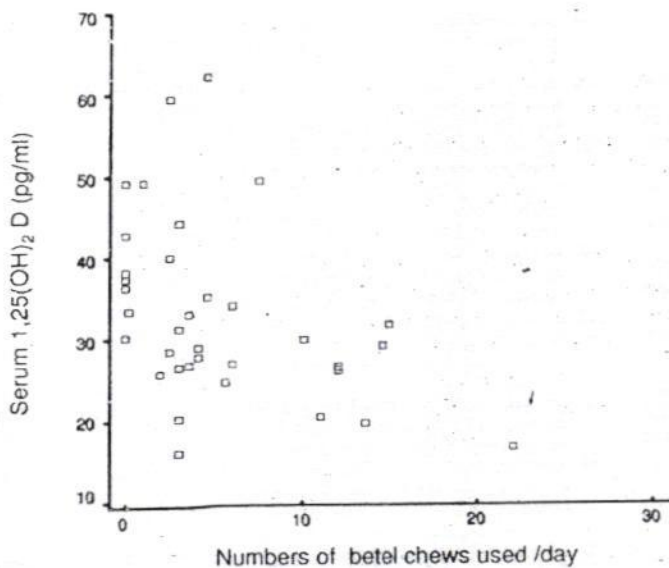

FIG. 2. Residual plot showing the relation of serum 1,25(OH)<sub>2</sub>D concentration to numbers of betel quids chewed per day in five nonchewers and in subjects chewing increasing numbers of betel nut quids per day as revealed by multiple regression analysis (see Table 4 for the findings for determinants of the PBMC content of 24(OH)ase mRNA).

to be associated with decreasing expression of VDR mRNA and increasing expression of 1- $\alpha$ (OH)ase mRNA (7), these findings suggest that the biological processes of PBMC differentiation *in vivo* are similar to those identified *in vitro*. This is supported by our finding that circulating hormonal vitamin D [serum 1,25(OH)<sub>2</sub>D concentration] rather than vitamin D status (serum 25-OHD concentration) contributed to the determination of PBMC 1- $\alpha$ (OH)ase expression on multiple regression analysis.

Although the regulation of the 1- $\alpha$ (OH)ase and 24(OH)ase genes in PBMCs is not yet fully defined (34–36), defects in up-regulation of macrophage 1- $\alpha$ (OH)ase expression in response to immune stimuli have been shown to contribute to the development of type 1 diabetes in autoimmune nonobese diabetic mice (36). Such defects, whether inherent or as a result of vitamin D deficiency, will reduce the availability of activated vitamin D in target tissues leading to decrease in both macrophage differentiation and recruitment from circulating monocytes (7). The increased risks of chronic inflammatory disorders, metabolic syndrome, and autoimmune disorders reported in South Asians and others with vitamin D deficiency could well be aggravated by the effects of betel chewing on 24(OH)ase, and the reductions in risk of type 1 diabetes reported after early life supplementation with vitamin D in white Caucasians could also be diminished in betel chewers (18–20).

Betel chewing is common among South Asian populations; it is the fourth most common habit after smoking, alcohol, and caffeine, and is estimated to be practiced by 600 million people globally (27). The mutagenic, genotoxic, and carcinogenic properties of betel nut (*Areca catechu*) extracts are well established (27). The fact that we have found betel usage to be a more powerful independent determinant of 24(OH)ase expression than vitamin D status in these subjects on multiple regression analysis (standardized coefficient of

correlation 0.72 vs. 0.34) suggests that this effect should be further investigated because such large proportions of the world population chew betel nut and are liable to vitamin D deficiency (4, 21, 22, 27, 28, 37). An association between consumption of betel nut and hyperglycemia has been reported experimentally (38) and similar associations have recently been reported in humans (39, 40), including dose-response effects in a large population-based study (40). Suggested mechanisms responsible for the association of the chewing of *Areca catechu* (betel) nut with disease include glutathione depletion, generation of free radicals, mitochondrial dysfunction, disturbance of the cell cycle, induction of apoptosis, and DNA damage (27). The actions of *Arecal* alkaloids, including  $\gamma$ -aminobutyric acid receptor blockade, have been widely studied, and *Arecal* nitrosamine derivatives are accepted as being carcinogenic in the human by the International Agency for Research on Cancer (27). Furthermore, drugs known to induce vitamin D deficiency such as rifampicin and carbamazepine recently have been shown to up-regulate expression of the 24(OH)ase gene through activation of the nuclear pregnane X receptor both in the human hepatocyte and, experimentally, *in vivo*, with increases in circulating 24,25-dihydroxyvitamin D (41). Therefore, it is possible that the ingestion of *Arecal* alkaloids, nitrosation adducts, or other components of betel chews might have a similar effect.

In conclusion, these preliminary data demonstrate that 1- $\alpha$ (OH)ase gene expression in circulating PBMCs relates inversely to VDR expression in humans, matching previous *in vitro* observations that hormonal vitamin D increases 1- $\alpha$ (OH)ase gene expression in PBMCs. This supports previous suggestions as to how monocyte activation (and thus macrophage efficacy) may be reduced in vitamin D deficiency (7). These preliminary findings also support the hypothesis that the habit of chewing betel (paan quids containing *Areca catechu* nut) could reduce the availability of active vitamin D by dose-dependent increases in expression of the 24(OH)ase enzyme catabolic for activated vitamin D. Further investigation of these phenomena would be useful because, if confirmed, they provide mechanisms that could contribute to the explanation of the increased risk of chronic inflammatory and autoimmune disorders found in hypovitaminosis D and also to the increased 24(OH)ase enzyme activity reported in South Asians and thus to the particular severity of vitamin D deficiency in South Asian populations.

#### Acknowledgments

The authors thank Dr. D. Syndercombe-Court for advice and assistance with PBMC preparation, Prof. H. DeLuca and Dr. J. Prahil for permission to reexamine the PBMC VDR-protein data, and M. F. McDermott and E. Aganna for VDR genotyping.

Received December 16, 2005. Accepted April 24, 2006.

Address all correspondence and requests for reprints to: Graham A. Hitman, M.D., Center for Diabetes and Metabolic Medicine, Royal London Hospital, London E1 1BB, United Kingdom. E-mail: g.a.hitman@qmul.ac.uk.

Grants from Diabetes UK and the North-East Thames (now "North Thames") R and D Directorate of the National Health Service contributed to the support of this work.

## References

- Holick MF 1989 Evolution, biologic functions, and recommended dietary allowances for vitamin D. In: Holick MF, ed. Vitamin D. Physiology, molecular biology and clinical applications. Chap 1. Totowa, NJ: Humana Press; 1-16
- Norman AW 1998 Sunlight, season, skin pigmentation, vitamin D, and 25-hydroxyvitamin D: integral components of the vitamin D endocrine system. *Am J Clin Nutr* 67:1108-1110
- Hollis BW 1996 Assessment of vitamin D nutritional and hormonal status: what to do and when to do it. *Calcif Tissue Int* 58:4-5
- Malaban A, Veronikis IE, Holick MF 1998 Redefining vitamin D deficiency. *Lancet* 351:805-806
- Zehnder D, Bland R, Williams MC, McNinch RW, Howie AJ, Stewart PM, Hewison M 2001 Extrarenal expression of the 25-hydroxyvitamin D<sub>3</sub> 1 $\alpha$ -hydroxylase. *J Clin Endocrinol Metab* 86:888-894
- Akeno N, Saikatsu S, Kawane T, Horiuchi N 1997 Mouse vitamin D-24-hydroxylase: molecular cloning, tissue distribution, and transcriptional regulation by 1 $\alpha$ ,25-dihydroxyvitamin D<sub>3</sub>. *Endocrinology* 138:2233-2240
- Kreutz M, Andreason M, Krause SW, Szabo A, Ritz E, Reichel H 1993 1,25-Dihydroxyvitamin D<sub>3</sub> production and vitamin D<sub>3</sub> receptor expression are developmentally regulated during differentiation of human monocytes into macrophages. *Blood* 4:1300-1307
- Hewison M, Freeman L, Hughes SV, Evans KN, Bland R, Eliopoulos AG, Kilby MD, Moss PA, Chakraverty R 2003 Differential regulation of vitamin D receptor and its ligand in human monocyte-derived dendritic cells. *J Immunol* 170:5382-5390
- Inomata S, Kadowaki S, Yamatani T, Fukase M, Fujita T 1986 Effect of 1 $\alpha$ (OH)-vitamin D<sub>3</sub> on insulin secretion in diabetes mellitus. *Bone Miner* 1:187-192
- Boucher BJ, Mannan N, Noonan K, Hales CN, Evans SJW 1995 Glucose intolerance and impairment of insulin secretion in relation to vitamin D deficiency in East London Asians. *Diabetologia* 38:1239-1245
- Boucher BJ 1998 Inadequate vitamin D status: does it contribute to the disorders comprising "Syndrome X"? *Brit J Nutr* 79:315-327
- Chiu KC, Chu A, Go VLW, Saad MF 2004 Hypovitaminosis D is associated with insulin resistance and  $\beta$  cell dysfunction. *Am J Clin Nutr* 79:820-825
- Holick MF 2004 Vitamin D: importance in the prevention of cancers, type 1 diabetes, heart disease and osteoporosis. *Am J Clin Nutr* 79:362-371
- Mathieu C, Gysemans C, Giulietti A, Bouillon R 2005 Vitamin D and diabetes. *Diabetologia* 48:1247-1257
- Wilkinson RJ, Llewelyn M, Toossi Z, Patel P, Pasvol G, Lalvani A, Wright D, Latif M 2000 Influence of vitamin D deficiency and vitamin D receptor polymorphisms on tuberculosis among Gujarati Asians in West London: a case-control study. *Lancet* 355:618-621
- Fitness J, Floyd S, Warndorff DK, Sichali I, Mwaungulu L, Crampion AC, Fine PE, Hill AV 2004 Large-scale candidate gene study of leprosy susceptibility in the Karonga district of Northern Malawi. *Am J Trop Med Hyg* 71:330-340
- Cantorna MT, Mahon BD 2004 Mounting evidence for vitamin D as an environmental factor affecting autoimmune disease prevalence. *Exp Biol Med* (Maywood) 229:1136-1142
- EURODIAB Study Group 2 1999 Vitamin D supplements in early childhood and risk for type 1 (insulin-dependent) diabetes mellitus. The Eurodiab Study 2 Study Group. *Diabetologia* 42:51-54
- Stene LC, Jøner G 2003 Use of cod-liver oil during the first year of life is associated with lower risk of childhood-onset type 1 diabetes: a large population-based, case control study. *Am J Clin Nutr* 78:1128-1134
- Hyponen E, Laara E, Reunanen A, Jarvelin MR, Virtanen SM 2001 Intake of vitamin D and risk of type 1 diabetes: a birth-cohort study. *Lancet* 358:1500-1503
- Murdur G 2003 Indian endocrinologists warn of vitamin D deficiency. *BMJ* 326:12
- Goswami R, Gupta N, Goswami D, Marwaha RK, Tandon N, Kochupillai N 2000 Prevalence and significance of low 25-hydroxyvitamin D concentrations in healthy subjects in Delhi. *Am J Clin Nutr* 72:472-475
- Awumey EM, Mitra DA, Hollis BW, Kumar R, Bell NH 1998 Vitamin D metabolism is altered in Asian Indians in the southern United States: a clinical research centre study. *J Clin Endocrinol Metab* 83:169-173
- Peacey SR, Wright D, Harries MJ 2004 Failure to normalize parathyroid hormone during treatment of vitamin D deficiency in Asian patients. *Clin Endocrinol (Oxf)* 61:603-606
- Ogunkolade BW, Boucher BJ, Prah J, Bustin SA, Burrin JM, Noonan K, North BV, Mannan N, McDermott MF, DeLuca HF, Hitman GA 2002 Vitamin D receptor (VDR) mRNA and VDR protein levels in relation to vitamin D status, insulin secretory capacity, and VDR genotype in Bangladeshi Asians. *Diabetes* 51:2294-2300
- DeLuca HF 1997 Historical overview. In: Feldman D, Glorieux FH, Pike JW, eds. Vitamin D. Chap 1. San Diego, London, Boston, New York, Sydney, Tokyo, Toronto: Academic Press; 3-11
- IARC monograph on the evaluation of carcinogenic risks to humans. 2004 Betel-nut and areca-nut chewing and some areca-nut-derived nitrosamines. Vol 85. Lyon, France: International Agency for Research on Cancer; ISBN 92 832 1285 1
- Lin SH, Lin YF, Cheema-Dhadli S, Davids MR, Halperin ML 2002 Hypercalcaemia and metabolic acidosis with betel nut chewing: emphasis on its integrative pathology. *Nephrol Dial Transplant* 17:708-714
- Timms PM, Mannan N, Hitman GA, Noonan K, Mills PG, Syndercombe-Court YD, Aganna E, Price CP, Boucher BJ 2002 Circulating MMP9, vitamin D and variation in the TIMP-1 response with VDR genotype: mechanisms for inflammatory damage in chronic disorders? *Q J Med* 95:787-796
- Hitman GA, Mannan N, McDermott MF, Aganna E, Hales CN, Boucher BJ 1998 Vitamin D receptor polymorphisms influence insulin secretion in Bangladeshi Asians. *Diabetes* 47:688-690
- Bustin SA 2000 Absolute quantification of mRNA using real-time reverse transcription polymerase chain reaction assays. *J Mol Endocrinol* 25:169-193
- Bustin SA 2002 Quantification of mRNA using real-time reverse transcription PCR (RT-PCR): trends and problems. *J Mol Endocrinol* 29:23-39
- Phillips DI, Clark PM, Hales CN, Osmond C 1994 Understanding oral glucose tolerance: comparison of glucose or insulin measurements during the oral glucose tolerance tests with specific measurements of insulin resistance and insulin secretion. *Diabet Med* 11:286-292
- Murayama A, Takeyama K, Kitanka S, Kodera Y, Hosoya T, Kato S 1998 The promoter of the human 25-hydroxyvitamin D<sub>3</sub> 1 $\alpha$ -hydroxylase gene confers positive and negative responsiveness to PTH, calcitonin, and 1,25(OH)<sub>2</sub>D<sub>3</sub>. *Biochem Biophys Res Comm* 249:11-16
- Hewison M, Freeman L, Hughes SV, Evans KN, Bland R, Eliopoulos AG, Kilby MD, Moss PAH, Chakraverty R 2003 Differential regulation of vitamin D receptor and its ligand in human monocyte-derived dendritic cells. *J Immunol* 170:5382-5390
- Overbergh L, Decallonne B, Valckx D, Verstuyf A, Depovere J, Laureys J, Rutgeerts O, Saint-Arnaud R, Bouillon R, Mathieu C 2000 Identification and immune regulation of 25-hydroxyvitamin D-1 $\alpha$ -hydroxylase in murine macrophages. *Clin Exp Immunol* 120:139-146
- Boucher BJ, Mannan N 2002 Metabolic effects of the consumption of *Areca catechu*. *Addict Biol* 7:103-110
- Boucher BJ, Ewen SWB, Stowers JM 1994 Betel nut (*Areca catechu*) consumption and the induction of glucose intolerance in adult CD1 mice and their F1 and F2 offspring. *Diabetologia* 37:49-55
- Mannan N, Boucher BJ, Evans SJW 2000 Increased waist size and weight in relation to consumption of *Areca catechu* (betel-nut): a risk factor for increased glycemia in Asians in east London. *Br J Nutr* 267-275
- Tung TH, Chiu YH, Chen LS, Wu HM, Boucher BJ, Chen THH 2004 A population based study of the association between areca-nut chewing and type 2 diabetes mellitus in men (Keelung Community-based Integrated Screening Programme No 2). *Diabetologia* 47:1776-1781
- Pascucci JM, Robert A, Nguyen M, Walrant-Debray O, Garabedian M, Martin P, Pineau T, Saric J, Navarro F, Maurel P, Vilarim M 2005 Possible involvement of the pregnane X receptor-enhanced CYP24 expression in drug-induced osteomalacia. *J Clin Invest* 115:177-186

JCEM is published monthly by The Endocrine Society (<http://www.endo-society.org>), the foremost professional society serving the endocrine community.

1267 &

## Hypothesis

# Hypercalcaemia and metabolic alkalosis with betel nut chewing: emphasis on its integrative pathophysiology

Shih-Hua Lin<sup>1</sup>, Yuh-Feng Lin<sup>1</sup>, Surinder Cheema-Dhadli<sup>2</sup>, Mogamat Razeen Davids<sup>3</sup> and Mitchell L. Halperin<sup>2</sup>

<sup>1</sup>Division of Nephrology, Department of Medicine, Tri-Service General Hospital, National Defense Medical Center, Taipei, Taiwan, <sup>2</sup>Renal Division, St Michael's Hospital, University of Toronto, Toronto, Canada and <sup>3</sup>Nephrology Unit and Department of Internal Medicine, University of Stellenbosch, Cape Town, South Africa

### Abstract

**Background.** Events in the gastrointestinal tract that might contribute to a high absorption of calcium were simulated *in vitro* to evaluate why only a small proportion of individuals who ingest alkaline calcium salts develop hypercalcaemia, hypokalaemia and metabolic alkalosis.

**Methods.** A patient who chewed and swallowed around 40 betel nuts daily developed hypercalcaemia, metabolic alkalosis, hypokalaemia with renal potassium wasting, and renal insufficiency. The quantities of calcium and alkali per betel nut preparation were measured. Factors that might increase intestinal absorption of calcium were evaluated.

**Results.** Hypercalcaemia in the index case was accompanied by a high daily calcium excretion (248 mg, 6.2 mmol). Circulating levels of 1,25-dihydroxyvitamin D<sub>3</sub> and parathyroid hormone were low. Hypokalaemia with a high transtubular K<sup>+</sup> concentration gradient, metabolic alkalosis, a low excretion of phosphate and a very low glomerular filtration rate were prominent features.

**Conclusions.** Possible explanations for the pathophysiology of metabolic alkalosis and hypokalaemia are provided. We speculate that a relatively greater availability of ionized calcium than inorganic phosphate in the lumen of the intestinal tract could have enhanced dietary calcium absorption.

**Keywords:** bicarbonate; calcium; hypokalaemia; milk-alkali syndrome; phosphate

### Introduction

The triad of hypercalcaemia, metabolic alkalosis, and renal insufficiency characterizes the milk-alkali syndrome [1]. In the past, its most common presentation was in patients with peptic ulcer disease who took large amounts of milk and calcium carbonate (CaCO<sub>3</sub>). With the advent of better antacid therapy such as H<sub>2</sub> blockers and gastric H<sup>+</sup> pump inhibitors, the incidence of this syndrome has decreased. Recently, features of the milk-alkali syndrome have been described in patients who take alkaline calcium salts and vitamin D supplements to treat osteoporosis [2]. Another predisposing cause, betel nut chewing, is an under-estimated source of oral alkaline calcium salts [3]. Betel nuts are the main ingredient of a masticatory drug used in the Far East, Asia, and the South Pacific by an estimated 600 million people [4]. To overcome their bitter taste, alkaline calcium salts are included in the oral preparation.

To understand why only a few of the many individuals who ingest alkaline calcium salts develop hypercalcaemia, hypokalaemia and metabolic alkalosis, we simulated events in the gastrointestinal tract that could contribute to excessive intestinal absorption of calcium. This involves an interplay between the products of bacterial fermentation and the relative proportions of alkaline calcium salts and inorganic phosphate in segments of the intestinal tract where passive, paracellular, non-regulated absorption of ionized calcium occurs [5].

### Subjects and methods

#### Case

A 60-year-old male patient who developed hypercalcaemia, metabolic alkalosis, hypokalaemia with renal potassium (K<sup>+</sup>) wasting, and renal insufficiency associated with a heavy consumption of betel nuts was examined.

Correspondence and offprint requests to: Shih-Hua Lin, MD, Division of Nephrology, Department of Internal Medicine, Tri-Service General Hospital, Number 325, Section 2, Cheng-Kung Road, Neihu 114, Taipei, Taiwan. Email: LS21116@ndmcl.ndmctsgh.edu.tw

*Analysis of betel nut paste*

Samples of betel nut paste were obtained from vendors in Toronto, Canada, and in Taipei, Taiwan, to determine the amounts and nature of its calcium compounds. Single preparations were weighed and added to 10 ml of distilled water ( $n=6$ ) or 0.9% saline ( $n=5$ ). Prior to centrifugation, the mixture was vortexed vigorously at room temperature until the pH of the supernatant became constant ( $\sim 12.4$ ). The clear aqueous phase was assayed for ionized calcium. To obtain an estimate of its total calcium content, the entire preparation was dissolved in 1 N HCl prior to assay for calcium. A portion of the aqueous HCl extract was titrated back to the original pH with 0.1 N NaOH to determine whether some of the alkali in that solution was  $\text{CaCO}_3$  rather than calcium hydroxide ( $\text{Ca(OH)}_2$ ) or calcium oxide. If fewer  $\text{H}^+$  ions were to remain in solution after HCl addition, this would indicate that some of the anions accompanying calcium were bicarbonate and/or carbonate ( $\text{CO}_3^{2-}$ ) (a total  $\text{CO}_2$  analysis by titration [6]). The quantity of chloride ( $\text{Cl}^-$ ) and sodium ( $\text{Na}^+$ ) added was verified by direct assay.

A solution containing 1 mmol of  $\text{CaCO}_3$  and 2.5 mmol of phosphate buffer (pH 7.4) was incubated for up to 12 h at room temperature. The 2.5-fold excess of phosphate over calcium was selected to represent a typical dietary composition [7]. The aqueous phase was assayed for calcium and phosphate, and the quantity of precipitate was also determined.

$\text{CaCO}_3$  (1 mmol) was exposed to increasing amounts of HCl (total volume adjusted to 10 ml with distilled water,  $n=24$ ). Control solutions ( $n=6$ ) consisted of 1 mmol  $\text{CaCO}_3$  in a total volume of 10 ml  $\text{H}_2\text{O}$ . The clear aqueous phase was aspirated and assayed for ionized calcium. The quantity of HCl added was verified by direct measurement of  $\text{Cl}^-$ .

*Analytical techniques*

Calcium was measured by an ion-selective electrode (Model 97-20, Orion Research Inc., Beverly, MA, USA), and pH was measured by an Orion pH meter (perpHect Log R meter, Model 370, Orion Research Inc.). The concentration of  $\text{Cl}^-$  was measured by a  $\text{Cl}^-$  titrator (Radiometer, Model CMT-10) and  $\text{Na}^+$  and  $\text{K}^+$  were measured by flame photometry as previously described [8].

**Results***Case synopsis*

The 60-year-old male sought medical attention because of anorexia and constipation that were more marked over the past several weeks. He had lost 7 kg of weight in this period. There was no other pertinent past medical history. He denied any consumption of vitamin D supplements. By habit, he chewed approximately 40 betel nuts from *Areca catechu* on a daily basis, and had done so for more than 40 years. These nuts were wrapped in the leaves of *Piper betle* along with a calcium-containing paste. He had developed a psychological and physical dependence on this stimulant. Typically, he swallowed the saliva and the remainder of the betel nut preparation. The calcium content of samples that were estimated to represent the

amount of paste used in one preparation (0.1 g dry weight) was  $1.4 \pm 0.06$  mmol. Therefore, he consumed approximately 50 mmol of calcium per day in the 40 betel nuts. Back-titration with NaOH confirmed that the alkali was  $\text{Ca(OH)}_2$  rather than  $\text{CaCO}_3$ . The solubility of the  $\text{Ca(OH)}_2$  paste at room temperature was  $11.3 \pm 0.64$  mmol/l in water ( $n=6$ ) and  $12.5 \pm 0.57$  mmol/l in 0.9% saline ( $n=5$ ); the pH of the latter solution was 12.4. In contrast,  $\text{CaCO}_3$  was very sparingly soluble in water so its calcium and alkali load would have depended almost exclusively on swallowing if it had been the oral alkaline salt.

On physical examination, the patient was conscious and alert with a supine blood pressure of 114/70 mmHg, heart rate of 80 beats/min, respiratory rate of 14 breaths/min, and his body temperature was  $36.6^\circ\text{C}$ . In the upright position, his blood pressure fell to 102/64 mmHg and his pulse rate rose to 94 beats/min. The jugular veins were flat and there was no peripheral oedema. Cardiopulmonary and abdominal examinations were unremarkable. There were no focal neurological deficits except for bilateral hyporeflexia. His tongue, oral mucosa and the angles of his mouth were stained brick-red by the betel nut juice.

The most striking features revealed by the laboratory examination were hypercalcaemia (12.8 mg/dl, 3.2 mmol/l), metabolic alkalosis (plasma pH 7.47, bicarbonate 36 mmol/l), and a very high plasma creatinine and BUN level (calculated creatinine clearance was 8.1 ml/min) (Table 1). Serum intact parathyroid hormone (PTH) (2.7 pg/ml) and 1,25-dihydroxyvitamin  $\text{D}_3$  (1,25-(OH) $_2\text{D}_3$ ) levels (8.2 pg/ml) were below the normal range (PTH, 10–65 pg/ml; 1,25-(OH) $_2\text{D}_3$ , 16.4–42.4 pg/ml). Hypokalaemia (3.2 mmol/l) was present and accompanied by a urine  $\text{K}^+$  concentration of 21 mmol/l, a urine  $\text{K}^+$ /creatinine ratio of 2.3 and a transtubular  $\text{K}^+$  concentration gradient (TTKG) of 7. The urinary excretion of calcium was high (248 mg/day, 6.2 mmol/day, calcium/creatinine 0.64 vs

Table 1. Values on admission in the index case

	Plasma	Urine
pH	7.47	7.5
Bicarbonate (mmol/l)	36	-
$\text{PCO}_2$ (mmHg)	50	-
$\text{Na}^+$ (mmol/l)	137	64
$\text{K}^+$ (mmol/l)	3.2	21
$\text{Cl}^-$ (mmol/l)	91	42
Anion gap (mEq/l)	10	43
BUN (urea) (mg/dl (mmol/l))	47 (17)	-
Creatinine (mg/dl ( $\mu\text{mol/l}$ ))	9.7 (844)	108 (9400)
Glucose (mg/dl (mmol/l))	88 (5.0)	0
Calcium (mg/dl (mmol/l))	12.8 (3.2)	23.4 (5.9)
Phosphate (mg/dl (mmol/l))	5.7 (1.84)	5.9 (2.1)
Volume (l/day)	-	1.1
Albumin (g/dl)	3.9	-
Calculated values		
$\text{FE}_K$ (%)		6.5
TTKG		7.0
Ca/creatinine (mmol/mmol)	-	0.64

our upper limit of normal being 0.4 in mmol terms), and the urinary excretion of inorganic phosphate was very low (65 mg/day, 2.1 mmol/day).

The patient's haemoglobin level was 9.2 g/dl, white cell count was 7200/mm<sup>3</sup> and platelet count was 239 000/mm<sup>3</sup>. Trace proteinuria was present on urinalysis and there were granular casts seen on microscopic examination of the urine sediment.

Soft tissue calcification was not seen on a chest X-ray, abdominal X-rays or a <sup>99m</sup>Tc-diphosphonate whole body bone scan. Abdominal sonography revealed normal-sized kidneys, and nephrocalcinosis was not detected. There was no evidence of parathyroid gland enlargement on sonography. Band keratopathy was not seen on slit lamp examination. Panendoscopy did not reveal any malignancy.

Initial therapy included intravenous isotonic saline to re-expand his extracellular fluid (ECF) volume. His plasma calcium concentration fell between days 1 and 3 to 7.0 mg/dl (1.8 mmol/l); his plasma PTH level was 10-fold higher when he became hypocalcaemic. These data suggest that the fall in calcium input and the expanded ECF volume may have led to hypocalcaemia. At this point, his PTH level rose to 32 pg/ml. The degree of rise in PTH was less than reported by previous workers [9] and may represent the degree of PTH reserve or down-regulation that may occur with chronic hypercalcaemia. Nevertheless, either this degree of rise in PTH and/or a decreased rate of calcium excretion led to the subsequent rise in his plasma calcium concentration to the normal range (Table 2). Hypercalcaemia and metabolic alkalosis resolved completely within 1 week (Table 2). Although the patient's renal function improved considerably in this time interval, his GFR remained significantly depressed on discharge; serum creatinine declined initially from 9.7 to 3.0 mg/dl (844 to 251 µmol/l) (Table 2). The progress of his recovery in GFR could not be documented because he was lost to medical follow-up. The patient was advised to stop chewing betel nuts and, while in our care, he decreased his consumption to fewer than five nuts per day.

#### Additional studies

*Exposure of a calcium carbonate precipitate to an inorganic phosphate buffer.* This experiment was

designed to simulate events in the intestinal tract downstream from the duodenum. When 1 mmol of CaCO<sub>3</sub> was added to 2.5 mmol of inorganic phosphate at pH 7.4 for 12-h, much of the flaky CaCO<sub>3</sub> precipitate was converted to a hard, white precipitate of insoluble calcium phosphate (Ca<sub>3</sub>(PO<sub>4</sub>)<sub>2</sub>) over 12 h despite the absence of added H<sup>+</sup>. There was no detectable ionized calcium remaining in the solution. The content of inorganic phosphate fell progressively to 2.1 mmol as more precipitate formed, implying that 60% of the CaCO<sub>3</sub> was converted to Ca<sub>3</sub>(PO<sub>4</sub>)<sub>2</sub> at this time point.

*Calcium carbonate exposure to HCl.* When increasing amounts of HCl were added to a solution containing 1 mmol CaCO<sub>3</sub>, ionized calcium was released in a linear and equivalent fashion by the added H<sup>+</sup> (Figure 1). Hence, 100 mEq H<sup>+</sup> would need to be produced by bacterial fermentation in the lower intestinal tract to convert the total amount (50 mmol) of ingested CaCO<sub>3</sub> to ionized calcium. Much smaller amounts of H<sup>+</sup> would be needed to dissolve only a portion of the CaCO<sub>3</sub>; the patient only excreted 6 mmol of calcium in 24 h.

#### Discussion

Our aim was to identify the risk factors leading to the development of the major electrolyte abnormalities, including hypercalcaemia, metabolic alkalosis, and hypokalaemia, in association with excessive calcium and alkali intake. Considerable emphasis was placed on the case synopsis because it illustrates an under-emphasized cause being a high intake of alkaline

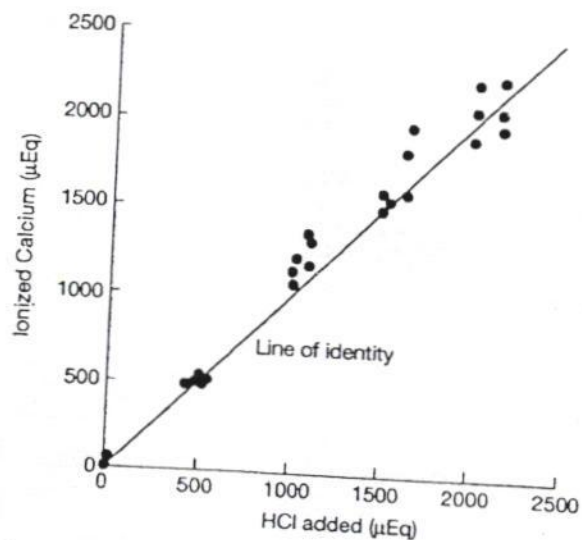

Fig. 1. Formation of ionized calcium by adding HCl to CaCO<sub>3</sub>. Increasing amounts of H<sup>+</sup>, when added to a solution containing 1 mmol of CaCO<sub>3</sub>, leads to the release of ionized calcium in a linear and equivalent amount. The source of these H<sup>+</sup> *in vivo* are gastric secretion of HCl and H<sup>+</sup> production during fermentation of carbohydrates downstream in the intestinal tract.

Table 2. Serial serum biochemical values in the index case

Day	0	1	3	7	14
BUN (mg/dl)	47	50	45	41	37
Creatinine (mg/dl)	9.7	9.3	6.3	5.6	3.0
Total calcium (mg/dl)	12.8	12.1	7.0	9.8	10.1
Phosphate (mg/dl)	5.7	3.6	3.3	-	-
Bicarbonate (mmol/l)	36	33	24	23	-
PCO <sub>2</sub> (mmHg)	50	47	39	-	-
Intact PTH (pg/ml)	2.7	-	32	44	-
1,25-(OH) <sub>2</sub> D <sub>3</sub> (pg/ml)	8.2	-	-	-	-

calcium salts in conjunction with a low absorption of inorganic phosphate.

### Hypercalcaemia

Calcium is absorbed in the duodenum by a highly regulated transcellular route, and downstream in the intestinal tract both by a regulated and by a passive

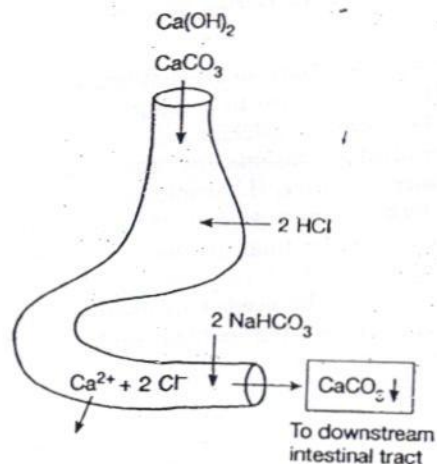

Fig. 2. Generation and absorption of ionized calcium in the upper intestinal tract. Alkaline calcium salts ( $\text{Ca}(\text{OH})_2$  and  $\text{CaCO}_3$ ) are poorly soluble in water. They are converted to ionized calcium by gastric HCl. There are three possible fates for ionized calcium leaving the stomach. Firstly, it can be removed by precipitation with inorganic phosphate (but not with organic phosphate). Secondly, while in its ionic form, calcium can be absorbed in the duodenum. Thirdly, when sufficient  $\text{NaHCO}_3$  is secreted into the duodenum, ionized calcium will be precipitated as  $\text{CaCO}_3$ . This  $\text{CaCO}_3$  will not react readily with inorganic phosphate produced by digestion of organic phosphates. Hence  $\text{CaCO}_3$  and inorganic phosphate are delivered downstream in the intestinal tract (see Figure 3).

non-regulated paracellular route, provided that calcium is in its ionized form [5]. The major regulator of intestinal ionized calcium absorption is  $1,25\text{-(OH)}_2\text{D}_3$ ; ionized calcium is formed when  $\text{Ca}(\text{OH})_2$  or  $\text{CaCO}_3$  reacts with HCl secreted in the stomach (Figure 2). Calcium remains ionized until sufficient sodium bicarbonate is secreted into the duodenum to form a luminal  $\text{CaCO}_3$  precipitate.

The aim of the first *in vitro* experiments was to determine the maximum concentration of ionized calcium in water or isotonic saline solutions that represent the possible extremes of salivary  $\text{Na}^+$  concentration [10]. With a typical salivary flow of 0.5 ml/min for 12 h per day [10] and an ionized calcium concentration of approximately 12 mmol/l, a maximum of about 4–5 mmol of calcium could be dissolved in saliva and swallowed daily. In contrast, if the entire betel nut paste and saliva were swallowed, the intake of calcium would be close to 52 mmol/day (1.4 mmol/sample  $\times$  40 samples). These values for calcium ingestion should be compared with a typical intake of 20 mmol of calcium per day and with the normal net absorption of up to 5 mmol/day [7]. Higher absorption rates cause hypercalcaemia [11].

If the  $\text{CaCO}_3$  precipitate formed in the duodenum were to remain intact downstream in the intestinal tract, there might be little further absorption of calcium. However,  $\text{CaCO}_3$  can be converted to ionized calcium in the lumen of the lower intestinal tract if there is a local source of  $\text{H}^+$  (Figure 3) [5]. Bacterial fermentation of undigested carbohydrates can provide 300 mmol of  $\text{H}^+$  per day [12]. Only a few mmol of  $\text{H}^+$  would be needed to dissolve enough  $\text{CaCO}_3$  to yield a luminal ionized calcium concentration exceeding that of plasma. This would permit passive calcium absorption if anions, such as inorganic phosphate, that could remove ionized calcium by precipitation were not

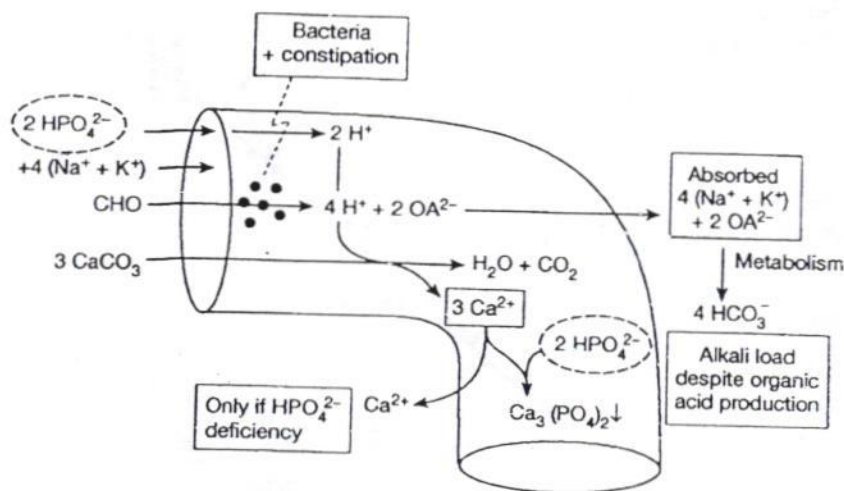
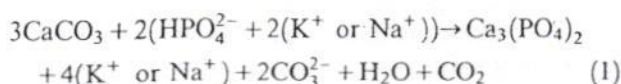

Fig. 3. Absorption of calcium downstream in the intestinal tract. The central structure represents downstream segments of the intestinal tract where calcium can be reabsorbed if it exists in an ionized form. Delivery of calcium is via a precipitate of calcium carbonate: ionized calcium ( $\text{Ca}^{2+}$ ) is formed when  $\text{H}^+$  is produced by bacterial fermentation and by conversion of inorganic phosphate ( $\text{HPO}_4^{2-}$ ) to  $\text{PO}_4^{3-}$ . Should the delivery of  $\text{HPO}_4^{2-}$  be less than required to precipitate  $\text{Ca}^{2+}$  as  $\text{Ca}_3(\text{PO}_4)_2$ , some  $\text{Ca}^{2+}$  could remain in the lumen and be absorbed. A potential bicarbonate load (organic anions ( $\text{OA}^{2-}$ )) is also absorbed representing the conversion of some of the alkali in  $\text{CaCO}_3$  to bicarbonate in the body when  $\text{OA}^{2-}$  are metabolized to neutral end-products [19].

present in the lumen of the intestinal tract, as shown by Equation 1:



The interplay between inorganic phosphate and ionized calcium is complex. Firstly, the bulk of inorganic phosphate is formed after the digestion of organic phosphates later in the upper intestinal tract. In quantitative terms, a typical diet supplies more than twice as much phosphate as calcium [7]. Nevertheless, as shown by our results, mixing insoluble  $\text{CaCO}_3$  with the expected 2.5-fold excess of inorganic phosphate at pH 7.4 removed 60% of the calcium from  $\text{CaCO}_3$  over a 12 h period, without ionized calcium being measurable in solution. Once  $\text{Ca}_3(\text{PO}_4)_2$  is formed, it should remain intact in the rest of the intestinal tract because the luminal pH distal to the stomach is not low enough to re-dissolve this precipitate. Secondly, to have a large enough quantity of ionized calcium in the lumen of downstream intestinal sites,  $\text{CaCO}_3$  would need to be present in quantities in excess of inorganic phosphate. This could occur if the source of dietary calcium was an intake of alkaline calcium salts, rather than sources of animal or vegetable origin (which need a low phosphate content). Moreover, once initiated, hypercalcaemia can cause a vicious cycle by leading to anorexia such that the intake of alkaline calcium salts in betel nut preparation, or as  $\text{CaCO}_3$ , might further exceed the dietary intake of phosphate. The net result would be increased calcium, but low phosphate absorption due to the precipitation of  $\text{Ca}_3(\text{PO}_4)_2$  in the lumen of the intestinal tract, as was suggested by the low excretion of phosphate (2 mmol/day vs the normal 20–30 mmol/day) in our case (Table 1). The soluble products of this precipitation reaction are  $\text{CO}_3^{2-}$  anions, yielding an absorbable alkali load (Figure 3, Equation 1).

One should also consider the properties of the anions produced by bacterial fermentation when there is less phosphate than calcium in the distal intestinal lumen. If some of these anions had properties similar to oxalate, ionized calcium would be removed by precipitation in the lumen of the intestinal tract. Hence, less ionized calcium would be available for absorption by the paracellular route. A low intake of milk could contribute to the development of the features in our patient [13]. Because milk is rich in phosphate, a low phosphate intake could diminish the precipitation of  $\text{Ca}_3(\text{PO}_4)_2$  downstream in the intestinal tract, allowing higher local ionized calcium levels (Figure 3). On the other hand, milk provides lactose that is said to augment the intestinal absorption of calcium [14]. Several mechanisms have been proposed to explain why a high oral lactose intake might increase intestinal calcium absorption. Firstly, the number of osmoles in the lumen could rise when lactose is hydrolysed into its component monosaccharides (glucose plus galactose) or into volatile fatty acid products by bacterial fermentation (lactic, butyric and propionic acid). As a

result of this osmole load, water might enter the lumen and cause it to distend. This distention could increase the permeability of the junctions between enterocytes and allow more ionized calcium to be absorbed by solvent drag [15,16]. In lactase-deficient subjects, there is an additional mechanism to consider. The very large  $\text{H}^+$  load from bacterial fermentation would increase the concentration of ionized calcium (Figure 3), thereby increasing its potential absorption [17,18].

#### *Metabolic alkalosis*

The ingestion of  $\text{CaCO}_3$  could provide an absorbable form of alkali if organic acids were produced in the lumen of the intestinal tract, provided that their conjugate bases (acetate, propionate and butyrate) were absorbed and metabolized to yield neutral metabolic end-products plus bicarbonate ions [19] (Figure 3). In fact, hypercalcaemia might augment the formation of organic acids and enhance the absorption of ionized calcium by slowing GI motility. One can obtain a crude estimate of how much alkali was absorbed along with calcium in our index case by examining the rate of excretion of calcium, at least in one 24 h urine collection period [7]. For the alkali accompanying calcium to remain as a bicarbonate in the body, calcium must remain in an ionic form or be excreted with an anion other than bicarbonate (e.g.  $\text{Cl}^-$  from  $\text{NaCl}$ ). Therefore the alkali load attributed to the net absorption of  $\text{Ca}(\text{OH})_2$  is equal to the daily renal excretion of ionized calcium (12 mEq/day). Because our patient was excreting more than 12 mEq of bicarbonate per day in his urine (pH 7.5, volume 1.1 l/day), another source of alkali would be needed to be in positive alkaline balance. Given his urine pH and GFR, the alkaline source was likely to have been a non-renal one because low excretion of ammonium means little addition of new bicarbonate to the body [20]. As shown in Figure 3 and Equation 1, the patient could, in theory, convert two-thirds of the alkali (carbonate) from the poorly absorbable  $\text{CaCO}_3$  into absorbable alkali by precipitation reactions in the intestinal tract.

Nevertheless, ingesting alkaline substances, even in large amounts, is not sufficient to cause the development of chronic metabolic alkalosis in normal subjects [21]. In subjects with marked renal insufficiency, the intake of  $\text{NaHCO}_3$  could lead to the development of metabolic alkalosis. If this were the sole cause, the ECF volume should be expanded. In contrast, if vomiting provided the bicarbonate load, the ECF volume would remain near its normal value. Given our patient's very low GFR, the metabolic alkalosis could be due in part to the input of bicarbonate, and due to a low rate of bicarbonate excretion because of the low filtered load for this ion. Therefore, the presence of calcium in the alkali load or the absence of a large intake of  $\text{Na}^+$  (in  $\text{NaHCO}_3$ ) might play a critical role in the metabolic alkalosis in our index case. Hence renal mechanisms were sought to explain why chronic metabolic alkalosis was present in this patient.

Hypercalcaemia and suppressed levels of PTH enhance the renal reabsorption of bicarbonate (left portion of Figure 4) [22] by stimulating the  $\text{Na}^+/\text{H}^+$  exchanger [23]. If enhanced proximal reabsorption of bicarbonate were the sole mechanism involved in this process, one would anticipate an expanded rather than a contracted ECF volume, as was seen in our case. Therefore we looked for a link between hypercalcaemia, metabolic alkalosis and a low ECF volume.

There were two important stimulators of proximal bicarbonate reabsorption in our case: angiotensin II ( $\text{A}_{\text{II}}$ ) [24] and hypokalaemia [25]. Hypercalcaemia might lead to high levels of  $\text{A}_{\text{II}}$  and hypokalaemia by producing a Bartter's-like effect because of occupancy of the calcium receptor on the basolateral aspect of cells of the medullary thick ascending limb of the loop of Henle (LOH) [26]. When occupied by calcium, the ROM-K ion channel in its luminal membrane becomes inhibited, and the lumen lacks  $\text{K}^+$  and its usual positive voltage. As a result, there is less reabsorption of  $\text{Na}^+$  and  $\text{Cl}^-$  as well as ionized calcium in the LOH. The consequences of this reabsorptive defect could lead to findings akin to the ROM-K defect subtype of Bartter's syndrome, with wasting of  $\text{Na}^+$ ,  $\text{Cl}^-$ ,  $\text{K}^+$  and calcium in the urine and the subsequent development of metabolic alkalosis [27]. A deficit of  $\text{Na}^+$  and  $\text{Cl}^-$  lowers the ECF volume, and leads to the release of renin and the formation of  $\text{A}_{\text{II}}$  [28]. Both hypokalaemia and high levels of  $\text{A}_{\text{II}}$  augment the reabsorption of bicarbonate in the proximal convoluted tubule (right side of Figure 4) [24]. Hence, there could be direct and indirect roles for calcium in causing an augmented

proximal reabsorption of bicarbonate. This form of metabolic alkalosis can be distinguished from that of vomiting because there is an abundant excretion of  $\text{Cl}^-$  in the urine in the absence of a diuretic (Tables 1 and 2).

#### Renal failure

Hypercalcaemia can cause arteriolar vasoconstriction within the kidney, a reduction in the ultrafiltration coefficient, a reduction in tubular  $\text{Na}^+$  reabsorption, acute tubular necrosis, nephrocalcinosis, and tubulointerstitial fibrosis, all of which can result in renal dysfunction via decreased GFR or direct tubular damage [29–31]. The coexistence of hyperphosphataemia, hypercalcaemia, ECF volume reduction and metabolic alkalosis could promote renal parenchymal calcification, an important pathological aspect of the syndrome that contributes to the development of renal dysfunction.

#### Perspectives

Patients who may be at risk of developing hypercalcaemia and secondary metabolic alkalosis include those individuals given  $\text{CaCO}_3$  and vitamin D supplements to delay the development of osteoporosis. Risk factors, such as low phosphate intake and factors that might affect the process of bacterial fermentation, should also be considered. These patients may be recognized initially by finding hypercalcaemia, subtle symptoms attributable to hypercalcaemia, an unexplained fall in GFR, or by the presence of electrolyte abnormalities such as hypercalcaemia, hypokalaemia and metabolic alkalosis. A high urine calcium:creatinine ratio in a random urine sample might be a reasonable screening test for the detection of a population at risk of these complications.

Patients with renal failure are often treated with  $\text{CaCO}_3$  to ensure that some of their dietary phosphate is converted to a non-absorbable form. This therapy should not lead to harmful effects related to excessive calcium absorption as long as their intestinal lumen contains more inorganic phosphate plus oxalate than ionized calcium. Notwithstanding, should a rare patient take too much  $\text{CaCO}_3$ , ingest too little dietary phosphate, and/or have an altered bacterial flora that decreases the availability of luminal oxalate, excessive absorption of calcium could occur. In this situation, hypercalcaemia and/or metastatic calcification might develop.

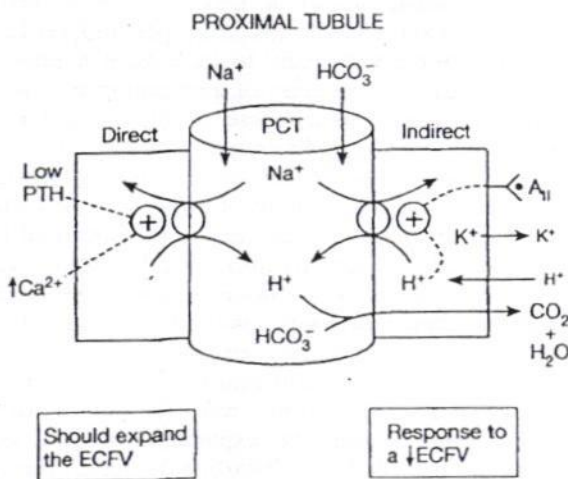

Fig. 4. Possible mechanisms to explain metabolic alkalosis and a contracted ECF volume. There are two possible and not mutually exclusive ways that metabolic alkalosis could occur as a result of hypercalcaemia. As shown on the left side of the figure, both hypercalcaemia and a suppressed PTH level can augment the reabsorption of  $\text{HCO}_3^-$  in the PCT. If these were the only actions, one might expect to find an expanded ECF volume. A second effect of hypercalcaemia is due to its loop diuretic-like effect that produces  $\text{Na}^+ + \text{Cl}^-$  and  $\text{K}^+$  wasting. The resultant high  $\text{A}_{\text{II}}$  levels and hypokalaemia could both act in concert to stimulate the reabsorption of bicarbonate in the PCT (right side of the left-hand portion of the figure). This mechanism of action is associated with a contracted ECF volume.

#### Concluding remarks

Our interpretation of the pathophysiology of hypercalcaemia, hypokalaemia and metabolic alkalosis in the case presented includes roles for the conversion of oral alkaline calcium salts to an absorbable form of ionized calcium due to bacterial production of  $\text{H}^+$  in the GI tract. Key to this being a potential clinical problem is the presence of a low phosphate intake

and/or the presence of phosphate binders in the lumen. Another risk factor is the consumption of the precursors of 1,25-(OH)<sub>2</sub>D<sub>3</sub> that could stimulate calcium absorption in the intestinal tract. At the renal level, hypercalcaemia could cause a Bartter's-like syndrome due to a loop diuretic-like effect contributing to the development of hypokalaemia, a K<sup>+</sup> deficit, a contracted ECF volume and an enhanced reabsorption of bicarbonate in the proximal convoluted tubule.

## References

1. Hardt LL, Rivers AB. Toxic manifestations following the alkaline treatment of peptic ulcer. *Arch Intern Med* 1923; 31: 171-180
2. Lin SH, Lin YF, Shieh SD. Milk-alkali syndrome in an aged patient with osteoporosis and fractures. *Nephron* 1996; 73: 496-497
3. Wu KD, Chuang RB, Wu FL, Hsu WA, Jan IS, Tsai KS. The milk-alkali syndrome caused by betelnuts in oyster shell paste. *Clin Toxicol* 1996; 34: 741-745
4. Nelson BS, Heischouer B. Betel nut: a common drug used by naturalized citizens from India, Far East Asia and the South Pacific Islands. *Ann Emerg Med* 1999; 34: 238-243
5. Lemann JJ Jr, Favus MJ. The intestinal absorption of calcium, magnesium and phosphate. In: Favus MJ, ed. *Primer on the Metabolic Bone Diseases and Disorders of Mineral Metabolism*. Lippincott Williams & Wilkins, Philadelphia, 1999; 63-67
6. Kildeberg P, Winters RW. Balance of net acid: concept, measurement and applications. *Adv Pediatr* 1978; 25: 349-381
7. Bushinsky DA. Calcium, magnesium and phosphorus: renal handling and urinary excretion. In: Favus MJ, ed. *Primer on the Metabolic Bone Diseases and Disorders of Mineral Metabolism*. Lippincott Williams & Wilkins, Philadelphia, 1999; 67-74
8. Halperin ML, Vinay P, Gougoux A, Pichette C, Jungas RL. Regulation of the maximum rate of renal ammoniogenesis in acidotic dogs. *Am J Physiol* 1985; 248: F607-F615
9. Beall DP, Scofield RH. Milk-alkali syndrome associated with calcium carbonate consumption. Report of 7 patients with parathyroid hormone levels and an estimate of prevalence among patients hospitalized with hypercalcemia. *Medicine* 1995; 74: 89-96
10. Schneyer LH, Young JA, Schneyer CA. Salivary secretion of electrolytes. *Physiol Rev* 1972; 52: 720-741
11. Veenstra TD, Kumar R. Hormonal regulation of calcium metabolism. In: Seldin DW, Giebisch G, eds. *The Kidney: Physiology & Pathophysiology*. Lippincott Williams & Wilkins, Philadelphia, 2000; 1792-1809
12. Halperin ML, Kamel KS. Turning sugar into acids in the gastrointestinal tract. *Kidney Int* 1996; 49: 1-8
13. Spitzer A, Kaskel FJ, Feld LG *et al.* Renal regulation of phosphate homeostasis during growth. *Sem Nephrol* 1983; 3: 87-93
14. Guise TA, Mundy GR. Disorders of calcium metabolism. In: Seldin DW, Giebisch G, eds. *The Kidney: Physiology & Pathophysiology*. Lippincott Williams & Wilkins, Philadelphia PA, 2000; 1811-1839
15. Norman DA, Morawski SG, Fordtran JS. Influence of glucose, fructose and water movement on calcium reabsorption in the jejunum. *Gastroenterology* 1980; 78: 22-25
16. Brommage R, Binacua C, Antille S, Carrie A. Intestinal calcium absorption in rats is stimulated by dietary lactose and other resistant sugars. *J Nutr* 1993; 123: 2186-2194
17. Kim KI, Benevenga NL, Grunmer RH. Estimation of the fraction of the lactose in a high lactose diet available for the fermentation in the cecum and colon of the rat. *J Nutr* 1978; 108: 79-89
18. Sasrela T, Simila S, Koivista M. Hypercalcemia and nephrocalcinosis in patients with congenital lactase deficiency. *J Pediatr* 1995; 127: 920-923
19. Halperin ML, Rolleston FS. *Clinical Detective Stories: A Problem-Based Approach to Clinical Cases in Energy and Acid-Base Metabolism*. Portland Press, London, 1993
20. Halperin ML. How much "new" bicarbonate is formed in the distal nephron in the process of net acid excretion? *Kidney Int* 1989; 35: 1277-1281
21. van Goidsenhoven GT, Gray OV, Price AV, Sanderson PH. The effect of prolonged administration of large doses of sodium bicarbonate in man. *Clin Sci* 1954; 13: 383-410
22. Massry SG, Kurokawa K, Arieff AI, Ben-Isaac C. Metabolic acidosis of hyperparathyroidism. *Arch Int Med* 1974; 134: 385-387
23. Cohn DE, Klahr S, Hammerman MR. Metabolic acidosis and parathyroidectomy increase Na<sup>+</sup>-H<sup>+</sup> exchange in brush border vesicles. *Am J Physiol* 1983; 245: F217-F222
24. Liu FY, Cogan MG. Angiotensin II: A potent regulator of acidification in the rat early proximal convoluted tubule. *J Clin Invest* 1987; 80: 272-275
25. Capasso G, Kinne R, Malnic G, Giebisch G. Renal bicarbonate reabsorption in the rat. I. Effects of hypokalemia and carbonic anhydrase. *J Clin Invest* 1986; 78: 1558-1567
26. Hebert SC. Extracellular calcium-sensing receptor: implications for calcium and magnesium handling in the kidney. *Kidney Int* 1996; 50: 2129-2139
27. Halperin ML, Kamel KS. Dynamic interactions between integrative physiology and molecular medicine: the key to understand the mechanism of action of aldosterone in the kidney. *Can J Physiol Pharmacol* 2000; 78: 587-594
28. Hollenberg NK. Set point for sodium homeostasis: surfeit, deficit and their implications. *Kidney Int* 1980; 17: 423-429
29. Orwel ES. The milk-alkali syndrome: current concepts. *Ann Intern Med* 1982; 97: 242-248
30. Palmer B, Alpern R. Metabolic alkalosis. *J Am Soc Nephrol* 1997; 8: 1462-1469
31. Benabe JE, Martinez-Mardonado M. Hypercalcemic nephropathy. *Arch Intern Med* 1978; 138: 777-779

1274  
8

### Areca nut, energy metabolism and hunger in Asian men.

Strickland SS, Veena GV, Houghton PJ, Stanford SC, Kurpad AV.

Cabinet Office, London, UK. Simon.Strickland@cabinet-office.x.gsi.gov.uk

#### Abstract

**BACKGROUND:** The nut of the Areca catechu palm has long been attributed effects on hunger and the digestive process.

**OBJECTIVES:** The objectives were to assess experimentally effects of areca nut on fasting and postprandial energy metabolism, substrate utilization and hunger.

**SUBJECTS AND METHODS:** Two randomized, placebo-controlled, double-blind studies were undertaken. In study 1, eight Indian men received bioadhesive gels delivering 0, 5, 10 or 20 mg arecoline to the buccal sulcus after an overnight fast. Resting energy expenditure and substrate utilization were determined by ventilated hood calorimetry over 6 h during which hunger was rated on five occasions. In study 2, 15 Indian men received gels delivering 0 or 10 mg arecoline after consuming a 2.5 MJ meal, and the same protocol was then applied as in study 1.

**RESULTS:** Fasting resting energy expenditures exceeded basal metabolic rate (BMR) by 5.4+/-0.8% (Mean+/-SE) after placebo, and 5.1+/-0.7% after 20 mg arecoline, but by 0.9+/-0.8% and 0.7+/-0.5% following 5 mg and 10 mg arecoline, respectively. Carbohydrate (CHO) utilization rates rose after areca nut compared to placebo (F(3,252)=7.3, p< 0.001). Hunger varied across doses (chi(2) = 10.5, p < 0.02), being lowest after 10 mg and highest after 20 mg, and was influenced by interaction of dose with delta resting energy expenditure. In study 2, areca dose interacted with fat-free mass (FFM) to lower by 5.4+/-11.2% the thermic effect of a meal (F(1,28) = 4.9, p = 0.05), and retarded peak 'digestive-phase' thermogenesis by 60 min (F(1,58) = 5.7, p = 0.02). Postprandial delta CHO utilization was greater (F(1,28) = 4.5, p = 0.05), and hunger was lower (chi(2) = 3.8, p = 0.05), after areca nut. The areca nut altered relationships of hunger to thermic effects of the meal, and to delta substrate utilization, in ways consistent with appetite suppression.

**CONCLUSION:** Areca nut constituents modulate metabolic signals regulating appetite in man. This concurs with customary belief.

1275 8

## Prevalence of tobacco use among young adult males in India: a community-based epidemiological study.

Saddichha S, Khess CR.

National Institute of Mental Health and Neurosciences, Bangalore, India. saddichha@gmail.com

### **Abstract**

**BACKGROUND:** Prevalence of tobacco use in India is reaching alarming proportions, despite efforts by both World Health Organization (WHO) and Government of India (GOI) in controlling it. Part of the problem has been lack of available data on tobacco use in various groups. Although Global Youth Tobacco Survey (GYTS) and National Family Health Survey (NFHS) III have focused on adolescents and adults, respectively, data on use among young adults is lacking. Another limitation has been the use of the questionnaire method to determine tobacco use which may not reveal exact prevalence. This study aimed to explore the prevalence of tobacco use among young adult males in Ranchi, as confirmed by serum cotinine levels.

**METHODS:** Five-hundred male students were selected through systematic randomized process to represent 5 universities in Ranchi. After informed consent, the students were administered Tobacco and Other Substance Use questionnaire and then subjected to urine Rapid Nicotine Test to improve sensitivity and biologically confirm prevalence. All tobacco users then were administered Fagerstrom's Scale for Severity of Nicotine Dependence.

**RESULTS AND CONCLUSION:** Biologically confirmed prevalence of tobacco use among male students was 55.6%, revealing high degree of prevalence in this age group. Predominant form of tobacco use was cigarettes (78%) followed by khaini (20%) and gutkha (2%), showing that most young adults use cigarettes possibly due to the 'cool image' associated with it. Seventy-seven percent of all tobacco users want to quit, thereby giving a strong opportunity to carry out cessation services in this group. There was higher mean Fagerstrom's Scale for Severity of Nicotine Dependence (FTND) score in smokers (6.7 +/- 2.2) compared to chewers (4.6 +/- 2.5), revealing higher severity of dependence among smokers than chewers.

Annals 1/1

## Does areca nut use lead to dependence?

Benegal V, Rajkumar RP, Muralidharan K.

Deaddiction Centre, Department of Psychiatry, National Institute of Mental Health and Neurosciences, Bangalore, India. vbenegal@gmail.com <vbenegal@gmail.com>

### Abstract

**BACKGROUND:** The areca nut is consumed by approximately 10% of the world's population, and its consumption is associated with long-term health risks, with or without tobacco additives. However, it is not known whether its use is associated with a dependence syndrome, as is seen with other psychoactive substances.

**OBJECTIVE:** To examine whether areca nut usage (with or without tobacco additives) could lead to the development of a dependence syndrome.

**METHODS:** Three groups: [a] persons using areca nut preparations without tobacco additives [n=98]; [b] persons using areca nut preparations with tobacco additives [n=44]; and [c] 'Non-users' were systematically assessed using a checklist for the use of areca or areca+tobacco products, patterns of use, presence of a dependence syndrome in users, features of stimulant withdrawal and desired/beneficial effects.

**RESULTS:** 38.8% and 40.8% of the 'areca' group satisfied definitions of current substance-dependence according to DSM-IV and ICD-10 criteria respectively. 79.5% of the areca+tobacco group satisfied criteria for current dependent use according to both DSM-IV and ICD-10 criteria. Both the groups reported a well-delineated withdrawal syndrome and similar attributions for desirable effects of use.

**CONCLUSION:** Areca nut use by itself and more so with tobacco additives, is associated with the development of a dependence syndrome in a substantial numbers of users.

The British Journal of Psychiatry  
**BJPsych**

**Effects of chewing betel nut (*Areca catechu*) on the symptoms of people with schizophrenia in Palau, Micronesia**

ROGER J. SULLIVAN, JOHN S. ALLEN, CALEB OTTO, JOSEPHA TIOBECH and KAREN NERO

*The British Journal of Psychiatry* 2000 177: 174-178  
Access the most recent version at doi:10.1192/bjp.177.2.174

---

**References** This article cites 13 articles, 3 of which can be accessed free at:  
<http://bjp.rcpsych.org/cgi/content/full/177/2/174#References>

Article cited in:  
<http://bjp.rcpsych.org/cgi/content/full/177/2/174#otherarticles>

**Reprints/permissions** To obtain reprints or permission to reproduce material from this paper, please write to [permissions@rcpsych.ac.uk](mailto:permissions@rcpsych.ac.uk)

**You can respond to this article at** <http://bjp.rcpsych.org/cgi/eletter-submit/177/2/174>

**Email alerting service** Receive free email alerts when new articles cite this article - sign up in the box at the top right corner of the article or [click here](#)

**Downloaded from** [bjp.rcpsych.org](http://bjp.rcpsych.org) on January 31, 2011  
Published by The Royal College of Psychiatrists

---

To subscribe to *The British Journal of Psychiatry* go to:  
<http://bjp.rcpsych.org/subscriptions/>

---

## Effects of chewing betel nut (*Areca catechu*) on the symptoms of people with schizophrenia in Palau, Micronesia

ROGER J. SULLIVAN, JOHN S. ALLEN, CALEB OTTO, JOSEPHA TIOBECH  
and KAREN NERO

**Background** Although millions of people with schizophrenia live in betel chewing regions, the effects of betel chewing on their symptoms are unknown. Betel nut alkaloids include potent muscarinic cholinomimetics: recent research suggests that these agents may be therapeutic in schizophrenia.

**Aims** To compare the primary and extrapyramidal symptom profiles and substance-using habits of betel chewing v. non-chewing people with schizophrenia.

**Method** A cross-sectional study of 70 people with schizophrenia. Symptom ratings measured by the Positive and Negative Syndrome Scale (PANSS) and Extrapyrimal Symptom Rating Scale (ESRS), and demographic and substance-use data, were compared for 40 chewers and 30 non-chewers of betel nut.

**Results** Betel chewers with schizophrenia scored significantly lower on the positive ( $P=0.001$ ) and negative ( $P=0.002$ ) sub-scales of the PANSS than did non-chewers. There were no significant differences in extrapyramidal symptoms or tardive dyskinesia.

**Conclusions** Betel chewing is associated with milder symptomatology and avoidance of more harmful recreational drugs. These initial results indicate that longitudinal research is merited.

**Declaration of interest** Supported by grants from the University of Auckland Research Council and the New Zealand Schizophrenia Fellowship.

'Betel chewing' describes the practice of masticating a quid of ingredients, including the seed of the *Areca catechu* palm (betel nut), the leaf of the creeping vine *Piper betle* and lime, usually in the form of burnt shell or coral. Betel nut is humanity's fourth most widely used drug after nicotine, ethanol and caffeine, and is chewed by millions of people living between the east coast of Africa and the western Pacific (Marshall, 1987).

Nine alkaloids constitute the active ingredients of betel nut (Farnworth, 1976), the most abundant of which is arecoline - a potent muscarinic agonist that rapidly crosses the blood-brain barrier and induces a range of parasympathetic effects (Asthana *et al*, 1996). Such cholinergic agents are again receiving attention as potential treatments for psychosis (Bodick *et al*, 1997; Tandon, 1999). Our principal hypothesis is that the muscarinic action of betel nut may exert a beneficial effect on the symptoms of people with schizophrenia. Since millions of people with schizophrenia live in betel-chewing regions, an increased understanding of the interaction between betel chewing and schizophrenia should benefit clinical treatment.

### METHOD

#### Research setting

The study was conducted in the Republic of Palau (population 17 000), the westernmost island group in Micronesia. As betel chewing is an integral cultural activity practised by more than 70% of the population (Ysaol *et al*, 1996; Futterman & Lyman, 1998), Palau is an ideal study context, combining a well-described and accessible schizophrenia population (Myles-Worsley *et al*, 1999) and a modern American-style health service.

### Subjects

Following ethical approval, the study was carried out at the Belau National Hospital between June and October 1998. The inclusion criteria were chronic schizophrenia or schizoaffective disorder (with mainly schizophrenic course), with an established DSM-III or DSM-IV (American Psychiatric Association, 1980, 1994) diagnosis.

Seventy-six informed and consenting out-patients, all indigenous Palauans, completed the study and were paid for their participation. Five subjects with bipolar disorder and one with acute schizophrenia were excluded, leaving a final pool of 70 subjects (49 men and 21 women). Fifty-four subjects were being treated with either haloperidol or fluphenazine (mainly by depot injection) and 48 were receiving anticholinergic medication. No participants were treated with atypical medications.

A recently completed genetic epidemiological study had identified and diagnosed 160 people with 'strictly defined' schizophrenia in Palau (Myles-Worsley *et al*, 1999). A number of these people were now deceased or 'off-island', leaving 122 people from the original group; the study sample therefore includes about 57% of the known Palauan schizophrenia population.

Fifty-two subjects (74.3% of the sample) chewed betel nut. However, this group included a proportion of casual users. The 'serious' betel chewer carries a kit of ingredients and is readily distinguishable from the 'social' user, who does not carry chewing paraphernalia but accepts a quid from peers in social situations. The casual users were included in the non-chewing group. After local advice on defining 'casual user', an arbitrary cut-off point was made at two or fewer betel nuts per day as the criterion for inclusion in the non-chewing group. This cut-off produced a chewing group of 40 and a non-chewing group of 30.

A subgroup of 16 subjects (10 chewers and 6 non-chewers) were not receiving antipsychotic pharmacotherapy and were used as a comparison group to control for the effects of medication.

### Instruments

The symptomatology of betel chewers was compared with non-chewers using the Positive and Negative Syndrome Scale (PANSS; Kay *et al*, 1992), the

Extrapyramidal Symptom Rating Scale (ESRS; Chouinard & Ross-Chouinard, 1979) and a self-report questionnaire of substance-using habits. In conjunction with demographic details, the substance-use questionnaire asked about consumption of betel nut, cigarettes, alcohol and marijuana. Self-reports were supplemented with reference to chart histories of substance misuse and consultation with case workers.

All rating was carried out by R.J.S. To avoid rater bias, the interviewer was blind to the chewing status of subjects until symptom rating was completed. The test batteries were conducted in English with the assistance of the study participant's case worker - either a psychiatric nurse or social worker. English is the language of instruction in Palauan schools and all subjects spoke English with varying degrees of fluency. The case worker helped each participant to complete the substance-use questionnaire and acted as interpreter when required during the PANSS interview and ESRS assessment that followed. Background information on the participant's social functioning required for the PANSS was obtained from the participant's chart, case worker and family.

Palauan case workers were consulted on the range of PANSS items as they related to each subject, particularly delusional content, communication and cognitive agility, and interpretation of affect. The Structured Clinical Interview for the PANSS (SCI-PANSS; Kay *et al.*, 1992) was translated into Palauan, then back-translated into English to provide a transcultural reference text for the rater and case workers. The westernised 'similarities' and 'proverbs' items of the 'abstract thinking' section of the PANSS were substituted with Palauan expressions and proverbs.

### Statistical tests

Differences in scale scores between sample groups were compared using the independent samples *t*-test. Non-parametric data were assessed using the  $\chi^2$ -test and the independent samples Mann-Whitney *U*-test. Correlations between continuous variables were assessed using Pearson's *r*. All tests were two-tailed. The 95th percentile (0.05) was considered the minimum level of statistically significant difference in all tests.

## RESULTS

### Demographic and clinical data by chewing status

Chewers and non-chewers were significantly different in the proportions who had ever married, in mean number of offspring and mean age at first admission to hospital (Table 1). With the exception of age at first admission, these differences are an artefact of the uneven gender distribution in the non-chewing group (87% male). The sample exhibits characteristic gender differences in marital status and number of children: 48% (10

of the women were or had been married, *v.* 10% (5) of the men ( $P=0.002$ ); and women averaged 2.3 (1.7 s.d.) children *v.* 0.5 (1.1 s.d.) children per man ( $P<0.001$ ). However, there were no significant differences in marital status or number of children in intra-gender comparisons (data not shown).

Among chewers the average betel nut consumption was 10.6 (5.7 s.d.) whole nuts (18.8 (11.1 s.d.) quids) per day. This figure is probably conservative, as an uncharacteristic dry season, attributed popularly to *El Nino*, resulted in a shortage of betel nut over the first few months of the study

Table 1 Demographic and clinical data by chewing status ( $n=70$ ). 'Chewers' defined as  $>2$  betel nuts per day

	Non- or casual chewers ( $n=30$ )	Chewers ( $n=40$ )	<i>P</i>
Whole nuts per day <sup>1</sup> (mean (s.d.))	0.5 (0.7)	10.6 (5.7)	-
Chews per day <sup>1</sup> (mean (s.d.))	0.8 (1.3)	18.8 (11.1)	-
Estimated chewing time, h/day <sup>2</sup> (mean (s.d.))	0.2 (0.3)	4.7 (2.8)	-
Age (mean (s.d.))	40.7 (9.3)	38.0 (6.7)	NS
Males ( <i>n</i> (%))	26 (86.7)	23 (57.5)	-
Females ( <i>n</i> (%))	4 (13.3)	17 (42.5)	-
Ever married ( <i>n</i> (%))	2 (6.6)	13 (32.5)	0.03
Number of children (mean (s.d.))	0.5 (1.2)	1.4 (1.7)	0.01
Years of education (mean (s.d.))	9.8 (3.0)	11.2 (2.9)	NS
Living with family ( <i>n</i> (%))	26 (86.7)	35 (87.5)	NS
Employed ( <i>n</i> (%))	4 (13.3)	10 (25.0)	NS
Age at onset (mean (s.d.))	23.1 (6.3)	21.9 (6.2)	NS
Age at first admission to hospital (mean (s.d.))	26.7 (8.7)	19.8 (12.1)	0.01
Number of admissions (mean (s.d.))	6.1 (5.0)	4.4 (4.9)	NS
Paranoid schizophrenia ( <i>n</i> (%))	10 (33.3)	11 (27.5)	NS
Residual schizophrenia ( <i>n</i> (%))	4 (13.3)	5 (12.5)	NS
Schizoaffective (mainly schizophrenia) ( <i>n</i> (%))	3 (10)	7 (17.5)	NS
Undifferentiated schizophrenia ( <i>n</i> (%))	10 (33.3)	10 (25)	NS
Other schizophrenia ( <i>n</i> (%))	3 (10)	7 (17.5)	NS
Chlorpromazine equivalents <sup>3</sup> (mg/day) <sup>4</sup> (mean (s.d.))	917.5 (977.0)	1003.9 (993.5)	NS
Benztropine (mg/day) <sup>5</sup> (mean (s.d.))	3.0 (1.6)	2.8 (1.4)	NS
<b>Unmedicated subgroup</b> ( $n=6$ )		( $n=10$ )	
Whole nuts per day (mean (s.d.))	0.7 (0.3)	13.1 (2.4)	-
Chews per day (mean (s.d.))	1.2 (1.5)	24.2 (15.8)	-
Estimated chewing time, h/day <sup>2</sup> (mean (s.d.))	0.3 (0.4)	6.0 (3.9)	-
Age (mean (s.d.))	38.3 (11.1)	41.1 (8.6)	NS
Males ( <i>n</i> (%))	5 (83.3)	6 (60)	-
Females ( <i>n</i> (%))	1 (16.7)	4 (40)	-

1. Some, but not all, chewers split each whole betel nut (*buuch*) and chew each half (*bitang*) separately.
2. Frequency of chews  $\times$  15 min duration of each chew (based on the duration of peripheral physiological effects; Chu, 1993).
3. The high mean chlorpromazine-equivalent dosages result from distributions heavily skewed by a small number of high-medication outliers in both groups (note the large standard deviations).
4. Non- or casual chewers:  $n=24$ ; chewers:  $n=30$ .
5. Non- or casual chewers:  $n=21$ ; chewers:  $n=27$ .

period: 29 members of the chewing group (72.5%) said that they were chewing less frequently than usual.

With the exception of the positive and negative sub-scales ( $r=0.18$ ), the PANSS sub-scales and total score are significantly intercorrelated. Therefore, although all PANSS sub-scale and symptom cluster data are reported with associated *P* values, statistically valid scale comparisons should be limited to those between the positive and negative sub-scales.

The mean PANSS scores for the chewing group were significantly lower than those for the non-chewing group on the positive, negative and general psychopathology sub-scales, as was the total score (Table 2). This trend was repeated in symptom cluster measurements of thought disturbance, paranoid belligerence and anergia. Scores on the ESRS of extrapyramidal symptoms (EPS) and tardive dyskinesia (TD) were not significantly different between the two groups. In comparison to a normative United States PANSS sample of 240 medicated North American patients with schizophrenia (Kay *et al.*, 1992), the positive and negative scale scores of non-chewers were 'average', and those of chewers were 'slightly below' to 'below average', suggesting that these group-symptomatology profiles are broadly comparable transculturally.

In the unmedicated subgroup, chewers scored significantly lower on the scale for negative symptoms and the anergia symptom cluster, on the general psychopathology scale and in total score (Table 3). There were no significant between-group differences in positive symptoms. The unmedicated chewers consumed more betel nut than medicated chewers (24.2 *v.* 18.8 quids/day) with an associated increase in estimated chewing time from 4.7 to 6 h/day (Table 1). No significant differences in EPS or TD scores emerged between the two groups.

### Other substances

Betel chewing was not associated with the use of other recreational substances, whereas nicotine, alcohol and marijuana consumption were significantly positively correlated (Table 4).

A significant negative correlation between cigarette smoking and betel chewing was found, that is, subjects tended to be either exclusively chewers or smokers (Table 4). However, most betel chewers

**Table 2** All subjects with schizophrenia: betel chewers (> 2 betel nuts per day) *v.* non-chewers ( $n=70$ )

	Chewers (mean (s.d.))	Non-chewers (mean (s.d.))	<i>t</i>	<i>P</i>
Positive and Negative Syndrome Scale (PANSS)	( $n=40$ )	( $n=30$ )		
Positive syndrome scale <sup>1</sup>	14.3 (5.7)	19.7 (6.6)	-3.3	0.001
Negative syndrome scale <sup>1</sup>	14.4 (6.7)	19.7 (7.1)	-3.2	0.002
General psychopathology scale	31.7 (8.1)	38.4 (9.0)	-3.2	0.002
Composite scale	-0.2 (8.1)	-0.6 (10.0)	0.2	NS
Total PANSS score	60.5 (16.5)	77.3 (17.3)	-4.1	<0.001
Thought disturbance symptom cluster	8.4 (4.1)	10.8 (4.4)	-2.3	0.02
Paranoid belligerence symptom cluster	5.1 (2.1)	7.3 (3.2)	-3.2	0.002
Anergia symptom cluster	8.5 (3.8)	10.5 (4.4)	-2.0	0.05
Activation symptom cluster	8.9 (1.6)	9.6 (1.9)	-1.6	NS
Depression symptom cluster	9.0 (3.6)	9.5 (3.7)	-0.5	NS
Extrapyramidal Symptom Rating Scale (ESRS)	( $n=39$ )	( $n=29$ )		
Parkinsonism	11.4 (9.1)	10.4 (5.8)	0.5	NS
Tardive dyskinesia	3.1 (3.4)	2.4 (2.6)	0.9	NS

1. Independent variables ( $r=0.18$ ).

**Table 3** Subjects with schizophrenia not receiving medication: betel chewers (> 2 betel nuts per day) *v.* non-chewers ( $n=16$ )

	Chewers (mean (s.d.))	Non-chewers (mean (s.d.))	<i>t</i>	<i>P</i>
Positive and Negative Syndrome Scale (PANSS)	( $n=10$ )	( $n=6$ )		
Positive syndrome scale <sup>1</sup>	15.4 (7.2)	17.8 (7.2)	-0.6	NS
Negative syndrome scale <sup>1</sup>	12.7 (5.8)	24.0 (8.2)	-3.2	0.006
General psychopathology scale	29.6 (9.5)	42.2 (13.9)	-2.2	0.05
Composite scale	2.7 (5.4)	-6.2 (10.2)	2.0	NS
Total PANSS score	57.7 (20.8)	84.0 (24.4)	-2.3	0.04
Thought disturbance symptom cluster	8.7 (5.0)	9.6 (3.6)	-0.4	NS
Paranoid belligerence symptom cluster	6.0 (2.8)	7.8 (5.2)	-0.9	NS
Anergia symptom cluster	7.4 (3.0)	14.3 (5.1)	-3.4	0.004
Activation symptom cluster	8.0 (1.4)	9.3 (2.6)	-1.1	NS
Depression symptom cluster	8.4 (4.5)	9.2 (4.5)	-0.3	NS
Extrapyramidal Symptom Rating Scale (ESRS)	( $n=9$ )	( $n=5$ )		
Parkinsonism	13.3 (13.1)	4.2 (4.0)	1.49	NS
Tardive dyskinesia	1.4 (2.4)	3.0 (3.3)	-1.0	NS

1. Independent variables ( $r=0.43$ ).

included tobacco as an ingredient of their chewing quid, resulting in a majority of subjects (91.4%) consuming tobacco either as part of a chewing quid or as smoked cigarettes. Smokers, none the less, consumed more tobacco, at an average of 13.8 cigarettes/day *v.* 6.1 for those who included tobacco in the betel quid.

Alcohol and marijuana consumption were not significantly related to PANSS symptom scores. The relationship between cigarette smoking and schizophrenia symptoms was a reversal of the betel data:

the total PANSS score of the smoking group was significantly higher than that of the non-smoking group ( $t=3.13$ ,  $P=0.002$ ).

### DISCUSSION

Although it has been previously suggested that betel nut alkaloids should be considered in the search for pharmacological treatments for schizophrenia (Smythies, 1977), to our knowledge this suggestion has not been pursued and this

Table 4 Correlation coefficients: substance consumption per day

	Betel	Cigarettes	Alcohol	Marijuana
Betel	1.0	-0.43*	-0.04	-0.17
Cigarettes		1.0	0.29*	0.44**
Alcohol			1.0	0.53**
Marijuana				1.0

\* $P < 0.05$ , \*\* $P < 0.01$  (two-tailed).

is the first study to investigate the effects of betel nut directly on the symptoms of people with schizophrenia.

Our results indicated that betel chewing is associated with less severe symptoms of schizophrenia as measured by the PANSS. Chewers scored significantly lower than non-chewers on the positive and negative symptom measures of the PANSS. The symptom score differences between groups were modest for the total group and balanced between positive and negative symptoms. When only subjects not receiving medication were considered, the group difference was substantial, mainly for negative symptoms. Among all subjects, the group total scores of chewers were significantly lower than those of non-chewers (60.5 *v.* 77.3,  $t = -4.1$ ,  $P \leq 0.001$ ) and among unmedicated subjects the difference in mean total PANSS score between chewers and non-chewers was dramatic (57.7 *v.* 84.0,  $t = -2.3$ ,  $P = 0.04$ ).

#### Muscarinic agonists in schizophrenia

The main study hypothesis, that betel chewing may exert a beneficial effect on the primary symptoms of schizophrenia, is supported by these results, and the muscarinic agonist action of the most abundant betel nut alkaloid, arecoline (Farnworth, 1976), provides the most promising pharmacological explanation for this effect.

Despite ambiguous results in early research (Davis *et al.*, 1978), a number of researchers propose that cholinergic agents may modulate dopaminergic hyperactivity and prevent the emergence of positive symptoms (Friedhoff & Alpert, 1973; Davis *et al.*, 1978; Tandon & Greden, 1989; Tandon, 1999). Research suggests that muscarinic agonist derivatives of arecoline may exert an atypical-like action, ameliorating both negative and positive

symptoms. Bodick *et al.* (1997) report that the selective  $M_1$  agonist xanomeline, a thiazazole derivative of arecoline (Moltzen & Bjornholm, 1995), produced dose-dependent reductions in delusions, hallucinations and other psychotic behaviours in a clinical trial with patients diagnosed with Alzheimer's disease. Shannon *et al.* (1998) performed preclinical rodent studies assessing the use of xanomeline as an anti-psychotic and produced results consistent with the performance of atypical agents. They conclude that "xanomeline may provide a novel approach to the treatment of psychosis with potential for a rapid onset of action, efficacy against positive and negative symptoms, and with little or no liability to produce extra-pyramidal side-effects" (see also studies on other muscarinic agents by Bymaster *et al.* (1998) and Shaanen *et al.* (1999)).

Betel nut arecoline may have similar effects to those of its derivatives described above. Betel chewers hold the betel quid in the buccal cheek cavity, utilising an absorption route that avoids first-pass metabolism and maintaining betel alkaloids in the blood stream for extended periods. The non-selective agonist action of arecoline may exert a crude atypical-like antipsychotic effect, in conjunction with the parasympathetic effects routinely tolerated by habitual users. Such an action may explain the favourable effect on negative symptoms and the generally mild EPS and TD among betel-chewing subjects with schizophrenia.

#### Extrapyramidal symptoms and tardive dyskinesia

Extrapyramidal symptoms resulting from betel nut consumption have been reported previously (Deahl, 1989). As discussed above, no significant differences emerged in ratings of EPS or TD between chewers and non-chewers. Additionally, no significant differences emerged in dosages of neuroleptic or anticholinergic medication.

Despite compliant (i.e. mainly depot) long-term neuroleptic medication with substantial dosages for many subjects, symptoms of TD were fairly infrequent among the study participants. Unambiguous TD symptoms, such as choreoathetoid or bucco-lingual movements, were seen in only 7 of the 70 participants (10%). In comparison, a previous analysis of 76 studies ( $n = 39187$ ) has reported a TD prevalence

of 24.2% cross-culturally (Yassa & Jeste, 1992).

#### Other substances

In accordance with findings reported elsewhere (Chong & Choo, 1996), our results show that smokers' PANSS scores were significantly higher than non-smokers'. The possibility that the favourable association between PANSS score and betel chewing is an artefact of non-smoking is unlikely, because most chewers consumed tobacco in their quid.

Similarly, the finding that betel nut tends to be used to the exclusion of other substances is of interest, but is unlikely to explain the favourable association between betel chewing and milder symptoms of schizophrenia, as neither marijuana nor alcohol consumption were significantly related to group PANSS scores.

#### Social variability

Betel chewing is a social activity in Micronesia and it may be associated with milder symptomatology simply because the practice itself is indicative of, or marks a return to, 'normal' social functioning (Wilson, 1979). However, a social functionality explanation for group differences in scale scores is not supported by the data, since there were no significant chewing *v.* non-chewing group differences in regard to demographic indicators of social functionality - marital status, number of children, living situation or employment status. Additionally, an assessment of social functioning is implicit in the structure of the PANSS instrument via input from family members and case workers. However, a suitable social functioning instrument is recommended in any subsequent research to more directly clarify associations between social functioning and betel chewing.

#### ACKNOWLEDGEMENTS

The authors thank the participating subjects and the many people instrumental in the completion of this study. In New Zealand: Dr J. Collier and Dr A. Futterman-Collier, M. Harrison, Professor R. Kydd, Professor R. Miller, Dr G. Robinson. In Micronesia: P. Anibuk, Dr G. Dever, A. Franz, Rev. F. Hezel, G. Johanes, H. Masayos, Dr M. Myles-Worsley, H. Ngral-mau, A. Lyman, D. Patris, Dr A. Polloi, Senator Peter and Akiko Sugiyama, Minister M. Ueda and the staff at Belau National Hospital. This research was supported by grants from the New Zealand Schizophrenia Fellowship and The University of

Auckland Research Committee. This study is dedicated to the memory of Dr A. Polloi.

## REFERENCES

- American Psychiatric Association (1980)** *Diagnostic and Statistical Manual of Mental Disorders* (3rd edn) (DSM-III). Washington, DC: APA.
- (1994) *Diagnostic and Statistical Manual of Mental Disorders* (4th edn) (DSM-IV). Washington, DC: APA.
- Asthana, S., Greig, N.H., Holloway, H.W., et al (1996)** Clinical pharmacokinetics of arecoline in subjects with Alzheimer's disease. *Clinical Pharmacology and Therapeutics*, **60**, 276–282.
- Bodick, N. C., Offen, W.W., Levey, A. I., et al (1997)** Effects of xanomeline, a selective muscarinic receptor agonist, on cognitive function and behavioural symptoms in Alzheimer disease. *Archives of Neurology*, **54**, 465–473.
- Byrnaster, F. P., Shannon, H. E., Rasmussen, K., et al (1998)** Unexpected antipsychotic-like activity with the muscarinic receptor ligand (5R,6R)-6-(3-propylthio-1,2,5-thiadiazol-4-yl)-1-azabicyclo[3.2.1]octane. *European Journal of Pharmacology*, **256**, 109–119.
- Chong, S. A. & Choo, H. L. (1996)** Smoking among Chinese patients with schizophrenia. *Australian and New Zealand Journal of Psychiatry*, **30**, 350–353.
- Chouinard, G. & Ross-Chouinard, A. (1979)** *Manual of Extrapyrmidal Symptom Rating Scale (ESRS)*. Montreal: Department of Psychiatry, McGill University.
- Chu, N. S. (1993)** Cardiovascular responses to betel chewing. *Journal of the Formosa Medical Association*, **93**, 835–837.
- Davis, K. L., Berger, P. A., Hollister, L. E., et al (1978)** Cholinergic involvement in mental disorders. *Life Sciences*, **22**, 1865–1872.
- Deahl, M. (1989)** Betel nut-induced extrapyramidal syndrome: an unusual drug interaction. *Movement Disorders*, **4**, 330–332.
- Farnworth, E. R. (1976)** Betel nut – its composition, chemistry and uses. *Sciences in New Guinea*, **4**, 85–90.
- Friedhoff, A. J. & Alpert, M. (1973)** A dopaminergic-cholinergic mechanism in production of psychotic symptoms. *Biological Psychiatry*, **6**, 165–169.
- Futterman, A. & Lyman, A. (1998)** *Palau Substance Abuse Needs Assessment (SANA)*. Koror: Palau Ministry of Health.
- Kay, S. R., Opler, L. A. & Fiszbein, A. (1992)** *Positive and Negative Syndrome Scale (PANSS): Manual*. New York: Multi-Health Systems, Inc.
- Marshall, M. (1987)** An overview of drugs in Oceania. In *Drugs in Western Pacific Societies. Relations of Substance*. ASAO Monograph No. 11 (ed. L. Lindstrom), pp. 13–49. Lanham: University Press of America.
- Moltzen, E. K. & Bjornholm, B. (1995)** Medicinal chemistry of muscarinic agonists: developments since 1990. *Drugs of the Future*, **20**, 37–54.
- Myles-Worsley, M., Coon, H., Tiobech, J., et al (1999)** A genetic epidemiological study of schizophrenia in Palau, Micronesia: prevalence and familiarity. *American Journal of Medical Genetics*, **88**, 4–10.
- Shannon, H. E., Byrnaster, F. P., Bodick, N. W., et al (1998)** Muscarinic agents: a new approach to the treatment of psychosis. Abstracts, 9th Biennial Winter Workshop on Schizophrenia, Davos, Switzerland, Feb. 7–13, 1998. *Schizophrenia Research*, **29**, 158.
- Calligaro, D. O., et al (1999)** Antipsychotic-like pharmacologic profile of the muscarinic agonist BuTAC. Abstracts, VII International Congress on Schizophrenia Research, Santa Fe, New Mexico, USA, April 17–21, 1999. *Schizophrenia Research*, **36**, 314.
- Smythies, J. R. (1977)** Betel nut as a GABA blocker. *American Journal of Psychiatry*, **134**, 822.
- Tandon, R. (1999)** Cholinergic aspects of schizophrenia. *British Journal of Psychiatry*, **174** (suppl. 37), 7–11.
- & Greden, J. F. (1989) Cholinergic hyperactivity and negative schizophrenic symptoms. A model of cholinergic/dopaminergic interactions in schizophrenia. *Archives of General Psychiatry*, **46**, 745–753.
- Wilson, L. G. (1979)** Cross-cultural differences in indicators of improvement from psychosis: the case of betel nut chewing. *Journal of Nervous and Mental Disease*, **167**, 250–251.
- Yassa, R. & Jeste, D. V. (1992)** Gender differences in tardive dyskinesia: a critical review of the literature. *Schizophrenia Bulletin*, **18**, 701–715.
- Ysaol, J., Chilton, J. I. & Callaghan, P. (1996)** A survey of betel nut chewing in Palau, *Isla – A Journal of Micronesian Studies*, **4**, 244–255.

## CLINICAL IMPLICATIONS

- In a sample comprising more than half of the known schizophrenia population in Palau, the symptoms of betel chewers as measured by total Positive and Negative Syndrome Scale (PANSS) scores were significantly milder than those of non-chewers. The differences were most dramatic in a small group of unmedicated subjects.
- Chewing was not significantly associated with increases in extrapyramidal symptoms (EPS), despite the cholinergic effects of betel chewing. However, EPS may have been masked in medicated subjects, as the majority were treated with anticholinergic medication.
- Betel chewing was not associated with the use of alcohol or marijuana and was inversely related to cigarette smoking.

## LIMITATIONS

- The relationship between milder symptomatology as measured by the PANSS and betel chewing is associative rather than causal. The study results highlight the need for pharmacokinetic/dynamic research of betel nut alkaloids via the buccal route, in conjunction with further research on the muscarinic cholinergic aspects of schizophrenia.
- The cross-sectional study design has methodological limitations and a prospective design is recommended for subsequent research.
- The analysis of social factors was limited to demographic data and the PANSS instrument. A suitable social functioning instrument is recommended in subsequent research, to clarify associations between social functioning and betel chewing.

ROGER J. SULLIVAN, Doctoral Candidate, Department of Anthropology, University of Auckland, Auckland, New Zealand; JOHN S. ALLEN, PhD, Division of Cognitive Neuroscience & Behavioral Neurology, Department of Neurology, University of Iowa Hospitals & Clinics, Iowa City, IA, USA and Department of Anthropology, University of Iowa; CALÉB OTTO, MBBS, Director of Public Health, Ministry of Health, Koror, Republic of Palau; JOSEPH A. TIOBECH, Senior Nurse, Behavioral Health Division, Belau National Hospital, Koror, Republic of Palau; KAREN NERO, PhD, Department of Anthropology, University of Auckland, Auckland, New Zealand

Correspondence: John S. Allen, Division of Cognitive Neuroscience & Behavioural Neurology, Department of Neurology – 2RCP, University of Iowa Hospitals & Clinics, Iowa City, IA 52242, USA

(First received 6 September 1999; final revision 21 February 2000; accepted 24 February 2000)

## Associations between betel nut (*Areca catechu*) and symptoms of schizophrenia among patients in Nepal: A longitudinal study.

Bales A, Peterson MJ, Ojha S, Upadhaya K, Adhikari B, Barrett B.

University of Wisconsin-Madison, USA. aliciabales@gmail.com

### **Abstract**

Betel nut is one of the mostly widely used substances in the world, particularly across Asia. Arecoline, a partial muscarinic agonist, has been hypothesized to have beneficial effects on both positive and negative symptoms of schizophrenia. This study aims to further explore associations between betel use and symptoms of schizophrenia in a 4-month longitudinal study in Nepal. Sixty Nepali patients with schizophrenia were recruited from regional outpatient clinics. The Positive and Negative Syndrome Scale (PANSS) and the Social Adaptation Self-Evaluation Scale were used to assess symptoms and social functioning in regular betel users and non-users. No significant group differences or dose-response relationships were noted on either initial or follow-up assessments. Stratifying by sex also failed to reveal an association between symptoms and betel use, which stands in contrast with previously reported data from Micronesia. There were no differences seen in social functioning other than a significantly higher proportion of betel users holding jobs. It was also noted that significantly fewer betel chewers were taking anti-cholinergic medication, which may tentatively indicate a potentially therapeutic role in the future for partial muscarinic agonists in the treatment of medication-induced movement disorders.

## The Effects of an Indigenous Muscarinic Drug, Betel Nut (*Areca catechu*), on the Symptoms of Schizophrenia: A Longitudinal Study in Palau, Micronesia

Roger J. Sullivan, Ph.D.  
 Sylvia Andres, D.Ch.M.S., P.G.Dip.M.H.  
 Caleb Otto, M.B.B.S.  
 Wayne Miles, M.B.Ch.B., M.D.  
 Robert Kydd, M.B.Ch.B., Ph.D.

**Objective:** This study tested the findings of a prior study indicating a therapeutic relationship between consumption of betel nut and symptoms of schizophrenia.

**Method:** The subjects were 65 outpatients with diagnoses of schizophrenia or schizoaffective disorder. Symptoms rated with the Positive and Negative Syndrome Scale were compared between high- and low-consumption betel chewers in a repeated-

measures design. Movement disorders were assessed with the Abnormal Involuntary Movement Scale and Simpson-Angus Rating Scale. Global health and social functioning were assessed with the Medical Outcomes Study 12-item and 36-item Short-Form Health Surveys, respectively.

**Results:** Male high-consumption betel chewers had significantly milder positive symptoms than low-consumption chewers over 1 year. Betel chewing was not associated with global health, social functioning, or movement disorders. Betel chewing was associated with tobacco use but not with cannabis or alcohol.

**Conclusions:** These findings have clinical significance in betel-chewing regions and broader implications for theory of muscarinic neurophysiology in schizophrenia.

(*Am J Psychiatry* 2007; 164:670-673)

**B**etel nut (*Areca catechu*) is ubiquitously chewed by millions of people from East Africa to the Pacific and is the fourth most widely used drug worldwide after caffeine, nicotine, and alcohol (1). Arecoline, the principal betel alkaloid (2), is a potent nonselective muscarinic agonist (3, 4). Several associations have been drawn between the pathophysiology of schizophrenia and muscarinic neurotransmission, including evidence for pathology of muscarinic receptors in people with schizophrenia (5), evidence that muscarinic agonists are efficacious in animal behavioral models of schizophrenia (6) and human clinical studies (7), and evidence of neurochemical interactions between dopaminergic and muscarinic neural systems (6). The results from a previously conducted cross-sectional pilot study in Palau, Micronesia, are suggestive of a therapeutic relationship between consumption of betel nut and the symptoms of schizophrenia (8, 9). The aim of the current research was to test the pilot study findings with a longitudinal research design in the same setting.

### Method

The study was carried out at the Behavioral Health Division, Palau National Hospital, between December 2002 and February 2004. Informed consent was obtained from 69 Palauan outpatients, 47 men and 22 women, with a DSM-IV diagnosis of schizophrenia or schizoaffective disorder (with mainly schizophrenic course). The participants were enrolled ad hoc at the time of their scheduled outpatient contacts with the Behavioral Health Division.

Rating instruments were a self-report substance use screen designed for the study, the Positive and Negative Syndrome Scale (PANSS) (10), the Medical Outcomes Study 12-item Short-Form Health Survey (version 2) (11), the social functioning subscale of the Medical Outcomes Study Short-Form Health Survey (version

2) (12), the Abnormal Involuntary Movement Scale (13), and the Simpson-Angus Rating Scale (14).

The study participants were rated in three assessment cycles: an initial "baseline" assessment, then at an average of 4 months and 8 months of follow-up. The field rater was a Palauan nurse trained in the administration of the research instruments at the Clinical Research and Resource Centre, Auckland, New Zealand. The PANSS interviews of seven participants (10.8% of completers) at baseline and six participants (9.2% of completers) in the second assessment cycle were videotaped for external interrater reliability testing, carried out by a team of Clinical Research and Resource Centre clinicians. Mean interrater coefficients for the PANSS positive and negative scales in the two assessment cycles ranged from 0.75 to 0.95.

Statistical tests were between-subjects analysis of variance, with PANSS and other scale ratings as dependent variables and gender and betel-consumption groups as independent factors. Participant betel nut consumption was the average of the three assessment cycles. The allocation of the participants into chewing and nonchewing groups was an issue in that the majority of participants were betel chewers, including a large proportion of sporadic casual users. These problems were addressed by forming factor groupings around the median of consumption. Therefore, non- and low-consumption betel chewers were those below or equivalent to the median of betel consumption among users in the group under consideration, and high-consuming betel chewers were the participants above the group median.

### Results

The 69 enrolled participants had a mean age of 41.9 years (SD=7.6), a mean age at onset of 22.9 years (SD=5.2), a mean age at first admission of 24.3 years (SD=9.0), and a mean duration of illness of 19.0 years (SD=7.9); the group had averaged 7.3 admissions since onset (SD=7.1). The mean chlorpromazine-equivalent dosage among the 60 participants (87.0%) receiving antipsychotic medication

TABLE 1. Clinical Characteristics of 45 Male Outpatients With Schizophrenia or Schizoaffective Disorder, by Betel Nut Chewing Status

Variable/Chewing Status <sup>a</sup>	N	Baseline		4 Months		8 Months		Main Effect for Chewing Status		
		Mean	SD	Mean	SD	Mean	SD	F	df	p
Positive and Negative Syndrome Scale positive symptoms										
High consumption	14	14.4	3.8	14.3	4.1	14.8	5.8	5.85	1, 43	0.02
Low consumption	31	18.9	6.9	18.5	6.5	19.3	7.4			
Positive and Negative Syndrome Scale negative symptoms										
High consumption	14	14.6	4.4	14.4	5.9	15.1	6.5	0.76	1, 43	0.39
Low consumption	31	17.3	5.6	14.9	3.9	15.6	4.9			
Medical Outcomes Study 12-item Short-Form Health Survey total score										
High consumption	14	39.0	8.1	40.4	8.4	40.0	7.0	0.12	1, 43	0.73
Low consumption	31	40.1	6.6	40.8	6.9	40.4	7.0			
Medical Outcomes Study 36-item Short-Form Health Survey social score										
High consumption	14	7.0	2.3	7.2	2.2	7.4	1.9	0.03	1, 43	0.87
Low consumption	31	7.3	2.1	7.4	2.0	7.5	1.5			
Abnormal Involuntary Movement Scale										
High consumption	14	4.3	6.1	2.1	2.6	0.6	2.4	2.86	1, 43	0.10
Low consumption	31	5.0	5.9	5.3	6.3	3.9	5.1			
Simpson-Angus Rating Scale										
High consumption	14	1.9	2.7	0.9	1.3	1.4	2.4	1.58	1, 43	0.22
Low consumption	31	2.0	2.1	2.2	2.2	2.0	2.5			
Betel chews (whole nuts/day)										
High consumption	14	11.3	6.0	13.1	4.6	14.2	8.0	95.84	1, 43	<0.0001
Low consumption	31	2.2	3.4	2.7	4.0	2.2	3.3			
Chlorpromazine equivalents										
High consumption	14	450.3	623.9	396.7	478.3	399.4	476.8	0.00	1, 43	0.99
Low consumption	31	432.1	402.5	390.3	326.5	427.3	418.0			
Benztropine										
High consumption	14	1.8	1.7	1.9	1.8	2.0	1.9	2.30	1, 42	0.14
Low consumption	31	2.9	1.6	2.7	1.5	2.6	1.5			

<sup>a</sup> High consumption: >median 7.5 whole betel nuts/day; low consumption: ≤ median 7.5 whole betel nuts/day.

was 438.4 mg/day (SD=368.6). Forty-nine patients (75.4%) were receiving a mean dosage of benztropine 2.7 mg/day (SD=1.3) anticholinergic medication.

Four patients did not complete the study or were excluded because of acute phases of illness during the assessment cycles. Among the 65 completers, 49 (75.4%) were betel chewers, 63 (96.9%) smoked and/or chewed tobacco, 22 (33.8%) drank alcohol, and 29 (44.6%) smoked cannabis during the course of the study. Both men and women consumed betel and tobacco, but consumption of alcohol or cannabis was predominantly a male phenomenon: 66.7% (N=30) of the men versus 20% (N=4) of the women ( $\chi^2=12.09$ ,  $df=1$ ,  $p=0.001$ ).

In repeated-measures analyses, there were no significant relationships between betel chewing and positive or negative symptoms for the entire cohort. However, an important finding of the 1998 pilot study was significant gender differences in symptoms and responses to betel chewing in Palauans with schizophrenia (9). When the data for men were analyzed separately, male high-consumption betel chewers (> median 7.5 betel nuts/day) had significantly lower positive symptoms than did low-consumption or nonbetel chewers (≤ 7.5 betel nuts/day) ( $F=5.85$ ,  $df=1, 43$ ,  $p=0.02$ ) (Table 1). In comparisons between the male high-consumption and low-consumption groups, there were no significant differences in PANSS-rated nega-

tive symptoms, global health and well-being as measured by the Medical Outcomes Study 12-item Short-Form Health Survey, social functioning as measured by the 36-item Short-Form Health Survey, tardive dyskinesia as rated by the Abnormal Involuntary Movement Scale, and parkinsonism as rated by the Simpson-Angus Rating Scale; there were also no significant differences in dosages of antipsychotic or anticholinergic medication (Table 1).

In analyses between betel nut consumption and the use of other drugs, there were no relationships between male betel chewing and cannabis or alcohol use, but there was significantly reduced total tobacco consumption among the high-betel-chewing group ( $F=7.05$ ,  $df=1, 42$ ,  $p<0.02$ ). When other drugs were assessed as independent covariates in relation to male positive symptoms and betel consumption, there were no significant interactions with mean total tobacco consumption ( $F=1.79$ ,  $df=1, 42$ ,  $p=0.19$ ), mean cannabis consumption ( $F=0.87$ ,  $df=1, 42$ ,  $p=0.36$ ), or mean alcohol consumption ( $F=0.55$ ,  $df=1, 42$ ,  $p=0.46$ ).

There were no significant relationships between betel chewing and positive or negative symptoms among the female participants. However, when we compared the women to the men as a group, the women showed a tendency toward lower PANSS-rated positive symptoms ( $F=3.47$ ,  $df=1, 63$ ,  $p<0.07$ ), significantly greater consumption of betel nut ( $F=8.20$ ,  $df=1, 63$ ,  $p=0.006$ ), and significantly

reduced total consumption of tobacco ( $F=7.95$ ,  $df=1$ ,  $63$ ,  $p=0.006$ ).

## Discussion

The results of this prospective naturalistic study are suggestive of a therapeutic relationship between betel chewing and positive schizophrenia symptoms among men, confirming similar findings in the 1998 pilot study (8; see reference 9 for gender differences). Tandon and Greden (15; see also reference 16) emphasize the importance of a modulating relationship between dopaminergic and cholinergic neurotransmission in the neurophysiology of schizophrenia, providing one possible theoretical rationale for the current study findings. They propose that muscarinic agonists exert a therapeutic effect by increasing cholinergic activity while dampening dopaminergic activity. The amelioration of positive symptoms among male high-consumption betel chewers in the current study is somewhat consistent with this model, although predicted concomitant acute extrapyramidal symptoms and elevated negative symptoms are absent. A second perspective is provided by Bymaster and colleagues (6), who noted that "many of the neurochemical effects of muscarinic agonists such as neurotransmitter release and Fos expression are similar to those of atypical antipsychotic agents." In this view, there are as yet poorly understood similarities between the action of muscarinic agonists and atypical antipsychotics that may underlie parallels in antipsychotic efficacy.

The absence of a relationship between movement disorders and betel consumption is counterintuitive given the cholinergic action of betel nut and may reflect tolerance to the cholinergic side effects of betel consumption among chronic users and/or documented gender and cross-cultural variability in the expression of tardive dyskinesia (17). The gender differences in betel nut consumption and related symptoms are also curious at first glance, but both animal (18) and human (19) studies have noted significant gender differences in behavioral and pharmacokinetic responses to cholinergic agents.

Previous research has suggested that betel consumption may be associated with a more favorable course of illness because chewing is a social activity pursued by relatively well individuals (20). Although results from the two-item social scale from the Medical Outcomes Study 36-item Short-Form Health Survey should be treated with caution, our analysis revealed no relationship between betel chewing and social functioning, or global health and well-being as measured by the 12-item Short-Form Health Survey.

There were no significant relationships between positive symptoms in men and the use of alcohol, cannabis, or tobacco in between-subjects factor analyses or when these other drugs were assessed as independent covariates. However, betel consumption is not independent of tobacco consumption in that most betel chewers in Palau

also chew or smoke tobacco and because both men and women high-betel users consumed approximately half as much tobacco as non- or low-betel users. The absence of a statistical relationship between schizophrenic symptoms and tobacco consumption in the study cohort suggests that the effects of betel and tobacco use are independent, but further research in a population that does not simultaneously use tobacco and betel is recommended.

Muscarinic agents are recognized as potential treatments for cognitive deficits associated with schizophrenia and other mental disorders (6). Future studies should include a suitable cognitive-functioning instrument to assess the relationship between betel consumption and cognitive deficits associated with schizophrenia. To date, both of the studies investigating the relationship between betel consumption and schizophrenia have been carried out in the Republic of Palau, and further research is required to test these findings in a different physical setting and cultural context.

Received Nov. 25, 2005; revision received May 10, 2006; accepted July 21, 2006. From the Department of Anthropology, California State University, Sacramento; the Behavioral Health Division, Belau National Hospital, and the Bureau of Public Health, Ministry of Health, Republic of Palau, Micronesia; and the Knowledge Centre, Waitemata Health, and the Department of Psychological Medicine, University of Auckland, Auckland, New Zealand. Address correspondence and reprint requests to Dr. Sullivan, Department of Anthropology, California State University, Sacramento, 6000 J St., Sacramento, CA 95819-6106; [sullivan@csus.edu](mailto:sullivan@csus.edu) (e-mail).

All authors report no competing interests.

Supported by grants from the Stanley Medical Research Institute (02R-225) and the New Zealand Schizophrenia Fellowship.

The authors thank the study participants, research assistant Nancy Mengloi, the nurses and staff at the Behavioral Health Division, Belau National Hospital, and J. Allen, P. Aribuk, J. Byrd, M. Biskowski, M. Di Domizio, A. Franz, A. Lyman, H. Masayos, K. Nero, G. Robinson, J. Tiobech, A. Wheeler, and two anonymous reviewers.

## References

1. Marshall M: An overview of drugs in Oceania, in *Drugs in Western Pacific Societies: Relations of Substance*: ASAO Monograph Number 11. Association for Social Anthropology in Oceania Monograph Series. Edited by Lindstrom L. Lanham, Md. University Press of America, 1987, pp 13-49
2. Farnworth ER: Betel nut—its composition, chemistry and uses. *Sci New Guinea* 1976; 4:85-90
3. Jakubík J, Bacáková L, El Fakahany EE, Tucek S: Positive cooperativity of acetylcholine and other agonists with allosteric ligands on muscarinic acetylcholine receptors. *Mol Pharmacol* 1997; 52:172-179
4. Asthana S, Greig NH, Holloway HW, Raffaele KC, Berardi A, Schapiro MB, Rapoport SI, Soncrant TT: Clinical pharmacokinetics of arecoline in subjects with Alzheimer's disease. *Clin Pharmacol Ther* 1996; 60:276-282
5. Katerina Z, Andrew K, Filomena M, Xu-Feng H: Investigation of m1/m4 muscarinic receptors in the anterior cingulate cortex in schizophrenia, bipolar disorder, and major depression disorder. *Neuropsychopharmacology* 2004; 29:619-625
6. Bymaster FP, Felder C, Ahmed S, McKinzie D: Muscarinic receptors as a target for drugs treating schizophrenia. *Curr Drug Targets CNS Neurol Disord* 2002; 1:163-181

7. Pfeiffer CC, Jenney EH: The inhibition of the conditioned response and the counteraction of schizophrenia by muscarinic stimulation of the brain. *Ann NY Acad Sci* 1957; 66:753-764
8. Sullivan RJ, Allen JS, Otto C, Tiobech S, Nero K: The effects of chewing betel nut (*Areca catechu*) on the symptoms of people with schizophrenia in Palau, Micronesia. *Br J Psychiatry* 2000; 177:174-178
9. Sullivan RJ: The Use of Betel Nut and Other Psychoactive Substances and Their Effects on the Symptoms of People with Schizophrenia in Palau, Micronesia. Unpublished doctoral thesis. Auckland, NZ, University of Auckland, 2001
10. Kay SR, Opler LA, Fiszbein A: Positive and Negative Syndrome Scale (PANSS): Manual. New York, Multi-Health Systems, 1992
11. Ware J Jr, Kosinski M, Keller SD: A 12-item short-form health survey: construction of scales and preliminary tests of reliability and validity. *Med Care* 1996; 34:220-233
12. Ware JE Jr, Sherbourne CD: The MOS 36-item Short-Form Health Survey (SF-36), I: conceptual framework and item selection. *Med Care* 1992; 30:473-483
13. Guy W (ed): ECDEU Assessment Manual for Psychopharmacology: Publication ADM 76-338. Washington, DC, US Department of Health, Education, and Welfare, 1976, pp 534-537
14. Simpson GM, Angus JWS: A rating scale for extrapyramidal side effects. *Acta Psychiatr Scand Suppl* 1970; 212:11-19
15. Tandon R, Greden JF: Cholinergic hyperactivity and negative schizophrenic symptoms: a model of cholinergic/dopaminergic interactions in schizophrenia. *Arch Gen Psychiatry* 1989; 46:745-753
16. Tandon R: Cholinergic aspects of schizophrenia. *Br J Psychiatry Suppl* 1999; 37:7-11
17. Yassa R, Jeste DV: Gender differences in tardive dyskinesia: a critical review of the literature. *Schizophr Bull* 1992; 18:701-715
18. Donny EC, Caggiula AR, Rowell PP, Gharib MA, Maldoyan V, Booth S, Mielke MM, Hoffman A, McCallum S: Nicotine self-administration in rats: estrus cycle effects, sex differences and nicotinic receptor binding. *Psychopharmacology (Berl)* 2000; 151:392-405
19. Craft RM: Sex differences in drug- and non-drug-induced analgesia. *Life Sci* 2003; 72:2675-2688
20. Wilson LG: Cross-cultural differences in indicators of improvement from psychosis: the case of betel nut chewing. *J Nerv Ment Dis* 1979; 167:250-251



## BETEL QUID CHEWING AND RISK OF ADVERSE BIRTH OUTCOMES AMONG ABORIGINES IN EASTERN TAIWAN

**Mei-Sang Yang**

School of Nursing, Kaohsiung Medical University, Kaohsiung, Taiwan

**Tieh-Chi Chung**

Taitung Hospital of Health Department, Executive Yuan, Taiwan

**Ming-Jen Yang**

Chang Gung University and Department of Psychiatry, Chang Gung Memorial Hospital, Kaohsiung, Taiwan

**Te-Yao Hsu**

Department of Obstetrics and Gynecology, Kaohsiung Chang Gung Memorial Hospital, Kaohsiung, Taiwan

**Ying-Chin Ko**

School of Medicine and Medical Institute, Kaohsiung Medical University, Kaohsiung, Taiwan

*It is known that substance abuse during pregnancy is associated with increased risk of adverse birth outcomes. The aim of this study was to determine the use of alcohol, cigarettes, betel quid, and drugs among pregnant aboriginal women and to assess the risk of adverse effects of betel quid use on birth outcomes in eastern Taiwan. Of a total of 229 women recruited into this study, 32 women with adverse birth outcomes constituted the case group. Analyses revealed that adverse birth outcomes were associated with maternal betel quid chewing and maternal age. After adjusting for maternal age, the risk of adverse birth outcome was five times higher among betel quid chewing women as compared to substance nonusers. Based on this finding, it is suggested health education, especially when concerned with the harmful effects of substance abuse, which includes betel quid use during pregnancy, should be stressed in concert with routine prenatal care.*

In the general population in Taiwan, the prevalence rate of betel quid chewing is approximately 10% irrespective of gender or age; however, in the aborigine population the rate of betel quid chewing is as high as 42% (Ko et al., 1995). Further, chewing betel quid is associated with alcohol drinking or cigarette smoking. The association between adverse birth out-

Received 24 January 2001; accepted 8 May 2001.

The authors express their thanks to director Amy Kao and the staff of the nursing department in St. Mary's Hospital for their help in collecting the data for this study. This study was supported by grants from National Science Council (NSC) (88-2314-b037-019) and in part from grant NHRI-GT-EX89P803L.

Address correspondence to Dr. Ying-Chin Ko, School of Medicine and Medical Institute, Kaohsiung Medical University, 100 Shih-Chuan 1st Road, Kaohsiung 80708, Taiwan. E-mail: ycko@kmu.edu.tw

comes and cigarette smoking or alcohol use has been widely studied (Larroque et al., 1993; Brown et al., 1996; Hulse et al., 1997; Bennett, 1999). However, few studies have examined the relationship between betel quid chewing and adverse effects on reproduction. Previously, Yang et al. (1999) found adverse pregnancy outcomes, including spontaneous abortion, premature labor, and stillbirth, in women who had chewed betel quid during their pregnancy.

Betel quid is a known cocarcinogen implicated in oral cancer (Ko et al., 1995; Lu et al., 1996). Betel quid consists of three ingredients: betel nut, slaked lime, and a piece of unripe fruit from piper betel. Consumption of betel nut is known to produce various autonomic nervous system effects including feeling warm, sweating, cardioacceleration, salivation, and enhanced alertness. The cytotoxicity and carcinogenic effects of betel nuts are well known (Dave et al., 1992; Jeng et al., 1999). The unripe piper betel fruit contains safrole, which is suspected to be a possible human carcinogen (Vainio & Wilbourn, 1992). In Taiwan, it has been found that 23.7% of aboriginal women chewed betel quid during their pregnancy, as compared to 0.78% of nonaboriginal women in eastern Taiwan (Lua et al., 1995). Due to the high prevalence of betel quid chewing in female aborigines (Yang et al., 1996), the negative health effects on pregnant mothers and developing children are of the greatest public health concern. However, little is known of the relationship between betel quid chewing and adverse birth outcomes. The purpose of this study was (1) to estimate the exposure rate of psychoactive substance use among aboriginal pregnant women, especially betel quid chewing, and (2) to assess the extent of adverse effects of betel quid chewing on birth outcomes.

## METHODS

### Study Population

From February to September 1998, 229 aboriginal women who gave birth during that period were recruited from a regional hospital in eastern Taiwan for this case-control study. The response rate was 70.1%. Among the participants, those had given birth to a child with (1) low birth weight at full term (birth weight less than 2500 g and with gestation of more than 37 wk), (2) preterm delivery (delivery before 37 wk), or (3) any malformation were considered as the case group. Thirty-two participants were recruited as the case group, which included 10 of low birth weight with full term, 20 preterm, and 2 with malformation. Participants whose babies were without any of these conditions constituted the control group ( $n = 197$ ). The average age of the mother in the case group was 29.1 yr (SD = 7.0 yr), average body weight before pregnancy was 57.0 kg (SD = 9.0 kg), weight after pregnancy was 70.0 kg (SD = 11.5 kg), average body height was 155.0 cm (SD = 4.8 cm), average husband body height was 168.1 cm (SD = 5.3 cm), and average husband body weight was 70.1 kg (SD = 9.2 kg). In the control group the average maternal age was 25.8 yr (SD = 5.6

yr), average body weight before pregnancy was 57.0 kg (SD = 10.5 kg) weight after pregnancy was 71.3 kg (SD = 11.4 kg), average body height was 157.1 cm (SD = 5.2 cm), average husband body height was 169.4 cm (SD = 5.6 cm), and average husband body weight was 71.9 kg (SD = 9.1 kg). There were no significant differences between the case and control mothers with the exception of average age, which was significantly higher in betel quid chewers.

#### Data Collection

The participants, who were admitted into the hospital (length of stay approximately 3–5 d) for delivery, were interviewed by trained interviewers using a questionnaire developed and evaluated by the authors. The questionnaire was designed to collect information about (1) sociodemographic background, (2) substance use (betel quid chewing, alcohol consumption, smoking, drug use) during pregnancy, and (3) obstetric data such as past obstetric history, parity, and birth outcomes including birth weight, body length, APGAR score, and malformation of newborn. Part 3 was completed according to the hospital's chart records. The majority of the participants completed the questionnaire within 72 h after their delivery.

#### Validity and Reliability

Five public health and two obstetric experts were called on to analyze the items of this questionnaire and oversee content coverage and adequacy. Reliability coefficients for the continuous or ordinary variables were reported in the range of 0.78 to 0.89 within the aboriginal women sample; the internal consistency in categorized variables was in the range of 0.85 to 0.91, respectively.

#### Statistical Analysis

Crude odds ratios (ORs) with 95% confidence intervals (CIs) or Student's *t*-test was used to examine the relationship between the birth outcome and the variables such as usage of betel quid, cigarettes, and alcohol. Similar procedures were applied to examine the relationship between adverse birth outcome and the sociodemographic or obstetric characteristics (age, education, sex of the infant, maternal body weight, blood relation, marital status, prenatal care, gravidity), and then subsequently examined using multiple logistic regression to assess the odds ratio (OR) of the significant variables in relation to the adverse birth outcome while at the same time controlling for other variables.

### RESULTS

The rate of substance use during pregnancy in the case group was found to be as follows: 65.6% for alcohol drinking (more than 3 drinks per occasion: 34.4%), 37.5% cigarette smoking, 68.8% for betel chewing, 75% cigarette smoking by husband. In the control group there were 48.73% alcohol drinking (more than 3 drinks per occasion: 23.4%), 22.3%

cigarette smoking, 48.7% betel chewing, and 75.6% cigarette smoking by husband. Bivariate analyses between case and control by maternal age, level of education, occupation, marital status, number of prenatal care (prenatal OPD visit: number of visits), gravidity, blood relations, maternal body weight and body height, husband's body weight and body height, husband's smoking habit, and husband's occupational exposure were performed. The partial results are shown in Table 1. There were no significant differences between the adverse birth outcome and maternal parameters except for age. The correlation between adverse birth outcome such as low birth weight or preterm birth and substance abuse is shown in Table 2. A significant association was found between low birth weight, preterm birth, and maternal betel quid chewing. The mean birth weight for the infants of betel quid chewers and those of betel nonchewers was 3030 and 3200 g, respectively, which was significant. Comparisons of the demographic variables, maternal alcohol drinking, cigarette smoking, and betel quid chewing during pregnancy between the case group and control group are shown in Table 3. The estimated odds ratio of adverse birth outcome was significantly higher in women who were betel quid chewers during their pregnancy. After controlling for maternal age, cigarette smoking, and alcohol consumption, a significantly higher rate of adverse birth outcome occurred in women who chewed betel quid during pregnancy (adjusted odds ratio, AOR = 5.0, 95% CI = 1.1–23.0). There also appeared to be an additive effect of cigarette smoking and alcohol consumption, as betel quid chewers who were exposed to these other known teratogens had a higher prevalence of adverse birth outcome than betel quid chewers who did not drink or smoke (AOR = 5.7, 95% CI = 1.6–20.3) (Table 4).

## DISCUSSION

The genotoxicity and carcinogenicity of tobacco and alcohol are well established. There is abundant evidence to indicate that there are adverse effects of alcohol drinking and cigarette smoking on birth outcome, in-

TABLE 1. Demographic and Selected Obstetric Features of Aborigines With and Without Adverse Birth Outcome

Maternal parameter	Aborigines without adverse birth outcomes, mean (SD)	Aborigines with adverse birth outcomes, mean (SD)
Age (yr)	25.8 (5.6)	29.1 (6.9)*
Body weight after pregnancy (kg)	71.3 (11.4)	69.9 (11.5)
Body weight before pregnancy (kg)	56.9 (10.5)	57.0 (9.0)
Height (cm)	157.1 (5.2)	155.0 (4.8)
Body weight increase during pregnancy (kg)	10.9 (17.1)	7.9 (21.8)

\*Significant versus no adverse birth outcome ( $p < .05$ ).

**TABLE 2.** Odds Ratios and 95% Confidence Intervals (CI) for Low Birth Weight (LBW) and Preterm Birth by Maternal Betel Chewing, Drinking, and Smoking Among Aboriginal Women

	LBW with full terms (n = 10)		Preterm (n = 20)	
	No/yes	OR (95% CI)	No/yes	OR (95% CI)
Maternal betel chewing				
No	110/1	1.0	79/3	1.0
Yes	109/9	9.1 (1.6-51.8)*	130/17	3.4 (1.1-11.4)*
Maternal drinking				
No	108/4	1.0	160/13	1.0
Yes	111/6	1.5 (0.4-5.3)	49/7	1.8 (0.7-4.6)
Maternal smoking				
No	167/6	1.0	105/7	1.0
Yes	52/4	2.1 (0.6-7.7)	104/13	1.9 (0.7-4.8)

\*Significant.

cluding low birth weight, preterm delivery, and malformations (Little et al., 1986; Ahlborg & Bodin, 1991; Larroque et al., 1993; Brown et al., 1996; Hulse et al., 1997; Bennett, 1999). A similar trend was found in this study, but due to the limited number of cases statistical significance was not reached. The habit of betel quid chewing, together with tobacco chewing or smoking, has been associated with an increased risk of oral cancers (IARC, 1985). Data in this study also demonstrated an additive adverse effect of betel quid chewing and smoking or alcohol on adverse birth outcome.

The fetotoxic potential of betel nuts has been investigated in rodents. It was found that arecoline, a component of betel nuts, is mutagenic (Shirname et al., 1983) and carcinogenic to rats (Nishikawa et al., 1992). Betel nuts also inhibit the synthesis of nucleic acids and protein in mouse fetuses (Sinha & Rao, 1985a). The mean weight of live mouse fetuses was found to be reduced by exposure to betel nuts in a dose-response manner (Sinha & Rao, 1985b). In humans a similar result was found in that the birth weight of babies born to pregnant betel nut chewers was significantly lower than that of infants born to women of similar age and province of birth but who had never chewed betel quid (De & Griew, 1982). Chewing betel quid was found to significantly reduce infant birth weight, confirming previous findings. It is of interest that maternal cigarette smoking also lowered infant birth weight.

In Taiwan, most betel quids are prepared with a piece of unripe piper betel fruit, which contains about 1% safrole, which is both genotoxic and mutagenic (Darroudi & Natarajan, 1993; Diamon et al., 1998). Our previous study found that the prevalence of adverse pregnancy outcome (such as abortion) was significantly higher among betel quid chewing women (Yang et al., 1999). Similar results were found in this study (data

not shown). The variables that were probably associated with low birth weight and premature delivery were examined, but no significant differences were found in maternal education, paternal smoking, previous pregnancies number, or paternal occupational exposure in this study. The mechanisms underlying fetal growth retardation and premature delivery due to exposure from maternal betel quid chewing remain poorly understood. As shown in rodents, betel quid components may inhibit the synthesis of nucleic acids and protein in fetuses (Sinha & Rao, 1985a).

There are a number of reasons cited for betel quid chewing during pregnancy: 20.1% for candy substitute, 17.5% as a savor, and 10% for an alertness effect. In tests to find out how betel quid chewing affects the

TABLE 3. Demographic Features and Substance Use During Pregnancy of Aborigines With and Without Adverse Birth Outcomes

	Control group, n (%)	Case group, n (%)	OR
Educational level			
> 9 yr	110 (55.8)	13 (40.6)	1.0
≤9 yr	87 (44.2)	19 (59.4)	1.9
Marital status			
Married	173 (87.8)	29 (90.6)	1.0
Others	24 (12.2)	3 (9.4)	0.8
Employment status			
Employed	36 (18.3)	8 (25)	1.0
Unemployed	161 (81.7)	24 (75)	0.7
Maternal betel chewing			
No	101 (51.1)	10 (31.3)	1.0
Yes	96 (48.9)	22 (68.7)	2.3*
Maternal smoking			
No	153 (77.7)	20 (62.5)	1.0
Yes	44 (22.3)	12 (37.5)	2.1
Maternal drinking			
No	101 (51.3)	11 (34.4)	1.0
Yes	96 (48.7)	21 (65.6)	2.0
Paternal smoking			
No	48 (24.4)	8 (25.0)	1.0
Yes	149 (75.6)	24 (75.0)	0.9
Paternal occupational exposure			
No	145 (73.6)	21 (65.6)	1.0
Yes	52 (26.4)	11 (34.4)	1.5
Maternal drug use			
No	194 (98.5)	32 (100)	—
Yes	3 (1.5)	0 (0)	—

\*Significant versus respective control.

TABLE 4. Adjusted Odds Ratios (AOR) and 95% Confidence Intervals (CIs) of Substance Use During Pregnancy in Aborigines With and Without Adverse Birth Outcomes

Substance use	Alcohol drinking					
	User			Nonuser		
	Cases/ controls	AOR <sup>a</sup>	(95% CI)	Cases/ controls	AOR <sup>a</sup>	(95% CI)
Betel chewing users						
User of cigarettes	9/33	5.7	1.6-20.3 <sup>b</sup>	1/6	3.2	0.3-33.4
Nonuser of cigarettes	7/42	3.1	0.8-11.3	5/15	5.0	1.1-23.0 <sup>a</sup>
Betel chewing nonusers						
User of cigarettes	1/3	4.5	0.3-69.5	1/2	10.7	0.8-152.5
Nonuser of cigarettes	4/18	4.3	0.98-19.0	4/78	1.0	—

<sup>a</sup>AOR: odds ratios adjusted for the maternal age covariate.

<sup>b</sup>Significant.

fetus, only 45% of the participants recognized the harmful effects. It is considered that a lack of knowledge may contribute to the significant higher rate of betel use during pregnancy in aborigines. Strategies of prevention or control of betel quid chewing among aboriginal women should include (1) cessation of substance use habits, (2) removal of carcinogenic components (piper betel fruit) and/or change to a safe substitute, and (3) emphasis on the undesirable effects of substance use on reproduction in the health-promotion side of prenatal care. This study is limited by the selected nature of the population examined and the heterogeneous population of adverse birth outcomes. Clearly, further research is needed.

## REFERENCES

- Ahlborg, G., and Bodin, L. 1991. Tobacco smoke exposure and pregnancy outcome among working women: A prospective study at prenatal care centers in Orebro County, Sweden. *Am. J. Epidemiol.* 133:338-347.
- Bennett, A. D. 1999. Perinatal substance abuse and the drug-exposed neonate. *Adv. Nurse Pract.* 7:32-36.
- Brown, H. L., Watkins, K., and Hiatt, A. K. 1996. The impact of the women, infants and children food supplement program on birth outcome. *Am. J. Obstet. Gynecol.* 174:1279-1283.
- Dave, B. J., Trivedi, A. H., and Adhvaryu, S. G. 1992. In vitro genotoxic effects of areca nut extract and arecoline. *J. Cancer Res. Clin. Oncol.* 118:283-288.
- Darroudi, F., and Natarajan, A. T. 1993. Metabolic activation of chemicals to mutagenic carcinogens by human hepatoma microsomal extracts in Chinese hamster ovary cells. *Mutagenesis* 8:11-15.
- De, C. C., and Griew, A. R. 1982. Effects of betel chewing on pregnancy outcome. *Aust. N. Z. J. Obstet. Gynaecol.* 22:22-24.
- Diamon, H., Sawada, S., Asakura, S., and Sagami, F. 1998. In vivo genotoxicity and DNA adduct levels in the liver of rat treated with safrole. *Carcinogenesis* 19:141-146.
- Hulse, G. K., English, D. R., Milne, E., Holman, C. D., and Bower, C. I. 1997. Maternal cocaine use and low birth weight newborns: A meta-analysis. *Addiction* 92:1561-1570.
- IARC. 1985. Betel-quid and areca-nut chewing. *IARC Monogr.* 37:141-291.

- Jeng, J. H., Tsai, C. L., Hahn, L. J., Yang, P. J., Kuo, Y. S., and Kuo, M. Y. P. 1999. Arecoline cytotoxicity on human oral mucosal fibroblasts related to cellular thiol and esterase activities. *Food Chem. Toxicol.* 37:751-756.
- Ko, Y. C., Huang, Y. L., Lee, C. H., Chen, M. J., Lin, L. M., and Tsai, C. C. 1995. Betel quid chewing, cigarette smoking and alcohol consumption related to oral cancer in Taiwan. *J. Oral Pathol. Med.* 24:450-453.
- Larroque, B., Kaminski, M., Lelong, N., Subtil, D., and Dehaene, P. 1993. Effect on birth weight of alcohol and caffeine consumption during pregnancy. *Am. J. Epidemiol.* 137:941-950.
- Little, R. E., Asker, R. L., Sampson, P. D., and Renwick, J. H. 1986. Fetal growth and moderate drinking in early pregnancy. *Am. J. Epidemiol.* 123:270-278.
- Lu, C. T., Lan, S. J., Yen, Y. Y., Ho, C. S., Hsieh, C. C., and Ko, Y. C. 1996. A case-control study of oral cancer in Changhua County, Taiwan. *J. Oral Pathol. Med.* 25:245-248.
- Lua, A., Wei, T. C., Liao, C. Y., Chen, C. Y., and Lin, D. Y. 1995. Ethanol and methamphetamine abuse in obstetric population in the Hualien Area. *Tzu Chi Med. J.* 7:111-118.
- Nishikawa, A., Prokopczy, B., Rivenson, A., Zang, E., and Hoffmann, D. 1992. A study of betel quid carcinogenicity of 3-(methylnitrosoamino) propionaldehyde in F344 rats. *Carcinogenesis* 13:369-372.
- Shirname, L. P., Menon, M. M., Nair, J., and Bhide, S. V. 1983. Correlation of mutagenicity and tumorigenicity of betel quid and its ingredients. *Nutr. Cancer* 5:87-91.
- Sinha, A., and Rao, A. R. 1985a. Transplacental micronucleus inducing ability of arecoline, a betel nut alkaloid in mice. *Mutat. Res.* 158:193-194.
- Sinha, A., and Rao, A. R. 1985b. Embryotoxicity of betel nuts in mice. *Toxicology* 37:315-326.
- Vainio, H., and Wilbourn, J. 1992. Identification of carcinogens within the IARC monograph program. *Scand. J. Work Environ. Health* 18:64-73.
- Yang, M. S., Ko, Y. C., and Wen, J. K. 1996. Prevalences and related factors of substances use in female aborigines in southern Taiwan. *Kaohsiung J. Med. Sci.* 11:634-640.
- Yang, M. S., Chang, F. T., Chen, S. S., Lee, C. H., and Ko, Y. C. 1999. Betel quid chewing and risk of adverse pregnancy outcomes among aborigines in Southern Taiwan. *Public Health* 113:189-192.

## SHORT REPORT

## Prenatal exposure to arecoline (areca nut alkaloid) and birth outcomes

O García-Algar, O Vall, F Alameda, C Puig, M Pellegrini, R Pacifici, S Pichini

Arch Dis Child Fetal Neonatal Ed 2005;90:F276-F277. doi: 10.1136/adc.2004.061325

The betel nut is commonly used as a drug by Asian populations. A high prevalence of adverse pregnancy outcomes has been reported in women who chewed betel quid during gestation. The hypothesis that chronic exposure of the fetus to arecoline (the principal alkaloid of the areca nut) is the cause was investigated in a clinical observational study on six newborns from Asian mothers who chewed betel nut during pregnancy.

The betel nut, composed of the sliced nut of the areca palm (areca nut), the leaf of the betel pepper (*Piper betle*), and lime, is a drug commonly consumed by Asian populations and Asian communities living in Europe and North America.<sup>1</sup>

Some authors have reported a significantly higher prevalence of adverse pregnancy outcomes, including spontaneous abortion, low birth weight, and preterm birth,<sup>2</sup> among women who chewed betel quid during gestation than in non-consumers. However, none hypothesised chronic exposure of the fetus to arecoline (the principal alkaloid of the areca nut) as a possible mechanism.

To investigate if chronic exposure to arecoline can lead to adverse birth outcomes, some not yet recognised, we set up a clinical observational study on six newborns from Asian mothers who admitted to betel nut consumption during pregnancy.

Pregnant women, recruited within the framework of the Meconium Project at the Hospital del Mar in Barcelona Spain, had a complete clinical examination and were interviewed about their use of cigarettes and illicit drugs during pregnancy. At the time of delivery, newborn somatometry and clinical signs were recorded.

Arecoline concentration was determined in meconium to assess fetal exposure to this alkaloid and in the placenta, to be associated with studies on the morphology of placental tissue from consumer mothers.<sup>3</sup> Meconium samples were also analysed for the principal drugs of abuse and cotinine to exclude prenatal exposure to drugs other than arecoline.

Two adverse birth outcomes were observed in the six exposed newborns (table 1). In both cases, risk factors other than chronic betel quid consumption could be excluded from maternal records, and neonatal brain ultrasonography was inconclusive. Focal inflammatory changes in the amniochorial membranes were observed in the placentas in both cases (table 1), and in case 3 a decreased median diameter of the vessels in both maternal and fetal surface villi was also observed.

Although the effects of betel chewing are well established in adults, teratogenic effects of prenatal betel exposure have only been shown in animal models,<sup>4</sup> and data for humans are scant.<sup>2</sup>

In our study, arecoline was determined in biological matrices accounting for acute and chronic fetal exposure to this substance, exposure associated with placental abnormalities, and neonatal outcomes, including neonatal withdrawal syndrome, as an exceptional adverse birth outcome not yet described in the literature. The recognised biochemical effects of arecoline on the autonomic nervous system and the recognised embryotoxicity in animals, together with our findings, allowed us to hypothesise a number of effects on the fetus related to abnormalities of the fetoplacental circulation, similar to those observed with nicotine or cocaine.

These preliminary findings did not allow any definitive conclusion on the correlation between fetal exposure to arecoline and clinical outcomes. Information on differences in patterns of drug use (amount, timing, and duration of drug exposure), related to clinical outcomes, was not

Table 1 Results of the clinical observational study on six newborns from mothers who chewed betel nut during pregnancy

Case No	Somatometry			Gestation (weeks)	Clinical signs	Placental morphology	Arecoline in biological matrices (µg/g)	
	Birth weight (g)	Crown-heel height (cm)	Cranial perimeter (cm)				Meconium	Placenta
1	3450	51	34	41	None	577 g; macro and micro normal	0.008	ND
2	3090	49	34	38	Neonatal withdrawal syndrome treated with 5 mg/kg phenobarbital for 3 subsequent days	655 g; macro normal; micro acute focal chorioamnionitis	NA	0.012
3	2430	47	33	41	Low birth weight, low intrauterine growth, small for gestational age, hyporeflexia, hypotonia	435 g; macro normal; micro acute focal chorioamnionitis, reduced vascular diameter	0.006	0.009
4	3260	49	34	39.6	None	548 g; macro and micro normal	0.022	0.013
5	2865	48	32	38.3	None	498 g; macro and micro normal	NA	0.015
6	3575	52	35	40.4	None	468 g; macro and micro normal	0.017	0.014

NA, Not available; ND, not detected.

available from the study questionnaire, nor could it be deduced from the arecoline concentration in the meconium, as is the case for other illicit drugs. Furthermore, as this was the first time that arecoline had been detected in meconium and placenta, no concentration ranges were available, which may have allowed speculations on amounts.

Our observations require support from further investigations, addressing the above issues and including an extended follow up of prenatally exposed newborns in areas with a high prevalence of betel nut consumption.

#### Authors' affiliations

O Garcia-Algar, O Vall, C Puig, Paediatric Service, Unitat de Recerca Infància i Entorn (URIE), Hospital del Mar, Barcelona, Spain and Departament de Pediatria, Ginecologia i Obstetrícia, i Medicina Preventiva, Universitat Autònoma, Barcelona, Spain  
F Alameda, Pathology Service, Hospital del Mar  
M Pellegrini, R Pacifici, S Pichini, Drug Research and Evaluation Department, Istituto Superiore di Sanità, Rome, Italy

This study was supported by "Area Progetto Droga" (Convenzione 513A/4) from Istituto Superiore di Sanità, Roma, Italy.

Competing interests: none declared

Correspondence to: Dr Garcia-Algar, Pediatric Service, Hospital del Mar, Paseo Marítimo 25-29, 08003 Barcelona, Spain; OGarciaA@imas.imim.es

Accepted 13 October 2004

#### REFERENCES

- 1 Gupta PC, Warnakulasuriya S. Global epidemiology of areca nut usage. *Addict Biol* 2002;7:77-83.
- 2 Yang MS, Chung TC, Yang MJ, et al. Betel quid chewing and risk of adverse birth outcomes among aborigines in eastern Taiwan. *J Toxicol Environ Health A* 2001;64:465-72.
- 3 Pichini S, Pellegrini M, Pacifici R, et al. Quantification of arecoline (Areca Nut alkaloid) in neonatal biological matrices by high-performance liquid chromatography/electrospray quadrupole mass spectrometry. *Rapid Commun Mass Spectrom* 2003;17:1958-64.
- 4 Langston C, Kaplan C, Macpherson T, et al. Practice guideline for examination of the placenta: developed by the Placental Pathology Practice Guideline Development Task Force of the College of American Pathologists. *Arch Pathol Lab Med* 1997;121:449-76.
- 5 Sinha A, Rao AR. Embryotoxicity of betel nuts in mice. *Toxicology* 2001;37:315-26.

#### bmjupdates+

bmjupdates+ is a unique and free alerting service, designed to keep you up to date with the medical literature that is truly important to your practice. bmjupdates+ will alert you to important new research and will provide you with the best new evidence concerning important advances in health care, tailored to your medical interests and time demands.

#### Where does the information come from?

bmjupdates+ applies an expert critical appraisal filter to over 100 top medical journals. A panel of over 2000 physicians find the few 'must read' studies for each area of clinical interest.

Sign up to receive your tailored email alerts, searching access and more...

[www.bmjupdates.com](http://www.bmjupdates.com)

Drug Alcohol Depend. 2008 May 1;95(1-2):134-9. Epub 2008 Feb 20.

## The effect of maternal betel quid exposure during pregnancy on adverse birth outcomes among aborigines in Taiwan.

Yang MS, Lee CH, Chang SJ, Chung TC, Tsai EM, Ko AM, Ko YC.

College of Nursing, Kaohsiung Medical University, No. 100 Shih-Chuan 1st Road, Kaohsiung 807, Taiwan.

### Abstract

In considering documented developmental toxicity and teratogenicity found in earlier research, maternal betel quid chewing may very well be linked to a higher risk of adverse birth outcomes. The aim of this study was to investigate the significance of betel quid chewing, together with the use of cigarettes or alcohol, either independently or combined, on birth-related outcomes. A total of 1264 aboriginal women who had just given birth in 10 hospitals in Southern and Eastern Taiwan were recruited. Information on their maternal and newborn characteristics was obtained from medical charts and by performing personal interviews using a validated questionnaire. Maternal areca nut chewing during pregnancy was found to be significantly associated with both birth weight loss (-89.54 g) and birth length reduction (-0.43 cm). A significantly lower male newborn rate (aOR=0.62) was observed among aboriginal women with a habit of betel quid chewing during pregnancy. The use of this substance conveyed a 2.40- and 3.67-fold independent risk of low birth weight and full-term low birth weight, respectively. An enhanced risk (aOR=3.26-5.99) of low birth weight was observed among women concomitantly using betel quid, cigarette and alcohol during gestation. Our findings suggest that betel quid chewing during pregnancy has a substantial effect on a number of birth outcomes, including sex ratio at birth, lower birth weight and reduced birth length.

## Betel nut chewing during pregnancy, Madang province, Papua New Guinea.

Senn M, Baiwoq F, Winmai J, Mueller I, Rogerson S, Senn N.

PNG Institute of Medical Research, PO Box 378, Madang, MP 511, Papua New Guinea. Michele.senn@gmail.com

### Abstract

**INTRODUCTION:** In Papua New Guinea, betel nut chewing is very common in the general population and in pregnant women. It has similarities in terms of use and complications of use to chewing tobacco (=smokeless tobacco), as its active agent, arecoline is similar to nicotine. The present study investigates the habits of betel nut chewing and possible impact on pregnancy.

**METHODS:** In a cross-sectional survey 310 pregnant women attending Alexishafen Health Centre (Madang Province) were interviewed with a survey measuring: detailed demographic data, betel nut chewing habits, other potential addictions (smoking, alcohol and drug use) and a medical examination (weight, height, blood pressure and hemoglobin level were recorded). Their babies have been assessed for birth weight and signs of prematurity.

**RESULTS:** Among pregnant women, 94% regularly chew betel nut, 9% smoke and 1% used alcohol. 31% are heavy chewers (>10 nuts/day). The principal reasons for pregnant women to chew are: to prevent morning sickness (28%), to prevent having a smelly mouth (26%), the habit of chewing (20%), being addicted (10%). Primigravidity, betel nut chewing and low BMI had a statistically significant impact on birth weight reduction of 467 g ( $p<0.001$ ), 238 g ( $p=0.02$ ) and 175 g ( $p=0.005$ ) respectively. 80% of the women thought that chewing would not have any effect on the fetus.

**DISCUSSION:** Given the high use of "pure" betel nut among pregnant women, a significant impact on birth weight reduction and a poor knowledge about the adverse health effects of this substance. prevention programs in pregnant women should include betel nut chewing as a risk factor for poor pregnancy outcome.

# Habitual Betel Quid Chewing as a Risk Factor for Cirrhosis A Case-Control Study

Jung-Fa Tsai, MD, PhD, Jen-Eing Jeng, MD, Lee-Yea Chuang, PhD, Mei-Shang Ho, MD, Yin-Chin Ko, MD, PhD, Zu-Yau Lin, MD, MS, Min-Yuh Hsieh, MD, Shin-Chern Chen, MD, PhD, Wan-Lung Chuang, MD, PhD, Liang-Yen Wang, MD, Ming-Lung Yu, MD, PhD, Chia-Yen Dai, MD, MS, and Chen Ho, MD

**Abstract:** Betel quid chewing, part of traditional Taiwanese culture, is common in 10%–20% of the human population worldwide. In this case-control study we assessed the independent and interactive role of habitual betel quid chewing and chronic hepatitis B virus (HBV) and hepatitis C virus (HCV) infection on risk of cirrhosis. Subjects enrolled included 210 pairs of sex- and age-matched cirrhotic patients and healthy controls. Information on risk factors was obtained through serologic examination of hepatitis B surface antigen (HBsAg) and antibodies to hepatitis C virus (anti-HCV), and a standardized personal interview with a structured questionnaire. Univariate analysis indicated that betel quid chewing, HBsAg+, anti-HCV+, alcohol drinking, and smoking are significant risk factors for cirrhosis. Multivariate analysis indicated that betel quid chewing (odds ratio [OR], 3.56), HBsAg (OR 20.37), and anti-HCV (OR 31.43) are independent risk factors for cirrhosis. Most betel quid chewers habitually drink alcohol. Although our analysis indicates that betel quid chewing acts independently from alcohol as a risk factor for cirrhosis, the confounding effect of alcohol cannot be excluded entirely by our study. There was an additive effect of the interaction between betel quid chewing and the presence of either HBsAg or anti-HCV. Moreover, a higher risk of cirrhosis was associated with longer duration of betel quid chewing and greater amount of betel quid consumed (each *p* for trend <0.0001). In conclusion, betel quid chewing appears to be an independent risk

factor for cirrhosis. There is an additive interaction between betel quid chewing and chronic HBV/HCV infection.

(*Medicine* 2003;82:365–72)

**Abbreviations:** anti-HCV = antibodies to hepatitis C virus, HBsAg = hepatitis B surface antigen, HBV = hepatitis B virus, HCV = hepatitis C virus, OR = odds ratio, CI = confidence interval

## INTRODUCTION

Cirrhosis is the end stage of all chronic disease affecting the liver<sup>5,14,23,32,34</sup>. It is a risk factor for hepatocellular carcinoma, although with a variable penetrance<sup>6,13,15,26–29,31,36,54–56,58,59,62–65</sup>. About 60%–89% of hepatocellular carcinoma is associated with underlying cirrhosis<sup>26,28,54,56,63–65</sup>, while the prevalence of hepatocellular carcinoma complicating cirrhosis is between 2.2% and 73%<sup>13,15,26,54,56,65</sup>. Although chronic hepatitis B virus (HBV) and hepatitis C virus (HCV) infection have been implicated as the major risk factors for cirrhosis<sup>3,11,12,20,53,54,61,62</sup>, some cirrhosis occurs in patients without serologic evidence of HBV/HCV infection<sup>1,5,10,14,16,18,37,38,53,60</sup>, suggesting that other viruses, environmental factors, or differences in lifestyle habits are also important. To prevent cirrhosis-associated mortality and morbidity, exploration of risk factors other than HBV/HCV is urgent.

Betel quid chewing is common in 10%–20% of the human population<sup>43</sup>, and is part of traditional Taiwanese culture<sup>30</sup>. The estimated number of habitual betel quid chewers is about one-tenth of the 22 million inhabitants of Taiwan<sup>30</sup>. The betel quid prepared in Taiwan is quite different from that in other parts of the world. It consists of 2 halves of a fresh areca nut, sandwiched with a piece of the betel leaf, and red slaked lime paste. Betel quid chewers generally swallow the saliva completely, thus bathing the epithelial lining of the upper digestive tract with the toxins released

From the Department of Internal Medicine, Clinical Laboratory, Biochemistry and Public Health, Kaohsiung Medical University College of Medicine, and the Institute of Biomedical Sciences, Academia Sinica, Taiwan.

Supported in part by a grant from the National Science Council of the Republic of China (NSC 85-2331-B-037-084 M14).

Accessible online at [www.md-journal.com](http://www.md-journal.com). To search for *Medicine* articles in PubMed, use the journal name "Medicine Baltimore" (include quotation marks).

Address correspondence and reprint requests to Professor Jung-Fa Tsai, Department of Internal Medicine, Kaohsiung Medical University College of Medicine, Kaohsiung 807, Taiwan. Fax: 886-7-312395; e-mail [jftsai@cc.kmu.edu.tw](mailto:jftsai@cc.kmu.edu.tw).

Copyright © 2003 by Lippincott Williams & Wilkins

ISSN: 0025-7974/03/8205-0365

DOI: 10.1097/01.md.0000090401.56130.59

during chewing. This increases the possibility of severe toxic effects of betel quid at sites other than the oral cavity.

Chronic inflammation of the liver appears to be a risk factor for cirrhosis regardless of the underlying etiology<sup>5,10,16,25,53,54,61,62</sup>. Experimental study has indicated that persistent hepatocellular damage occurs after chronic feeding with betel quid<sup>50,57</sup>. Therefore, habitual betel quid chewing may play a role in causing cirrhosis. However, the role of betel quid chewing in the development of cirrhosis, and its interaction with other known risk factors for cirrhosis, have never been explored adequately. In this case-control study we address the independent and interactive roles of habitual betel quid chewing and other known risk factors for cirrhosis.

## SUBJECTS AND METHODS

### Study Population

A total of 210 consecutive newly diagnosed cirrhotic patients were enrolled as cases. These patients were hospitalized or visited outpatient clinics at Kaohsiung Medical University Hospital from January 1996 to December 1997. There were 170 males and 40 females. During the same study period, 210 healthy community residents who entered the hospital for routine physicals, matched on age ( $\pm 5$  yr) and sex, were enrolled as the control group. There was no difference in the median age between cases (57 yr; range, 36–82 yr) and controls (58 yr; range, 36–82 yr). Cirrhosis was diagnosed by liver biopsy, abdominal sonography, and biochemical evidence of parenchymal damage plus endoscopic esophageal or gastric varices<sup>61,62</sup>. Patients with cirrhosis were classified into the 3 Child-Pugh grades based on their clinical status<sup>45</sup>. All healthy controls had normal serum aminotransferase levels and normal abdominal sonography. Informed consent was obtained from each subject studied. The study was approved by the Investigation and Ethics Committee of the hospital.

### Structured Questionnaire and Standardized Interview

We designed a structured questionnaire to obtain information on age, sex, educational level, habits of smoking (the quantity of cigarettes smoked per day and the duration of smoking), alcohol drinking (the quantity and duration of drinking, types of alcoholic beverage), and betel quid chewing practice (the duration of habit, daily amount consumed, type of betel quid consumed). A habitual betel quid chewer was defined as chewing 1 quid or more daily for at least 1 year. A habitual cigarette smoker was defined as smoking 1 cigarette or more per day for at least 1 year. A habitual alcohol drinker was defined as drinking an alcohol beverage for more than 4 days a week for a total of at least

1 year. All cirrhotic cases and matched controls were interviewed by interviewers trained in study details and questionnaire contents. All interviews were conducted in person using the structured questionnaire.

### Serologic Examination

Hepatitis B surface antigen (HBsAg) and antibodies to hepatitis C virus (anti-HCV) were detected by Ausria-II and second generation ABBOTT HCV EIA (Abbott Laboratories, North Chicago, IL), respectively. For anti-HCV, reactive specimens were retested. Only repeatedly reactive specimens were interpreted as anti-HCV positive. Conventional liver function tests were tested by an autoanalyzer (Hitachi, Model 736, Japan).

### Statistical Analysis

The Mann-Whitney U test was used to compare the difference between medians of continuous variables. The chi-square test with the Yates correction or the Fisher exact test was used to compare differences between proportions when appropriate. Mantel extension test for trend was used to examine the dose-response relationship for the risk estimates of various combinations of risk factors. Odds ratio (OR) with 95% confidence interval (95% CI) was used to estimate causal relations between risk factors and exposure. A conditional logistic regression analysis was used for multivariate analysis about risk factors for cirrhosis. Unconditional stepwise logistic regression analysis was used for risk factors for habitual betel quid chewing in cirrhotic patients. Adjusted odds ratios and 95% CI were derived from logistic regression coefficients to provide an estimate of the statistical association between a given variable and the disease (cirrhosis) with the other variables held constant. Synergy index was used to estimate the interactive effect among risk factors for cirrhosis<sup>49</sup>.

To calculate the population-attributable risk for factors significantly associated with cirrhosis development in multivariate analysis, the frequency distribution of these risk factors in the control group was used to represent the proportion of persons exposed to the factor in the general population. Two-tailed *p* values and 95% CI were given when appropriate. An alpha of 0.05 was considered as the indicator of statistical significance.

## RESULTS

### Demographic Characteristics of Cases and Controls

The frequency distribution of sex, age, status of HBsAg and anti-HCV, and Child-Pugh grades of the study population is shown in Table 1. More than 80% of cases and controls were between 40 and 69 years old. At least 1 marker

**TABLE 1. Characteristics of 210 Matched Pairs of Cirrhotic Cases and Healthy Community Controls**

Variables	Cases No. (%)	Controls No. (%)
<b>Sex</b>		
Male	170 (80.95)	170 (80.95)
Female	40 (19.04)	40 (19.04)
<b>Age (yr)</b>		
<40	7 (3.33)	5 (2.38)
40-49	42 (20.00)	39 (18.57)
50-59	74 (35.23)	78 (37.14)
60-69	59 (28.09)	64 (30.47)
≥70	28 (13.33)	24 (10.90)
<b>HBsAg/anti-HCV</b>		
Negative/negative	23 (10.95)	165 (78.57)
Positive/negative	127 (60.47)	36 (17.14)
Negative/positive	48 (22.85)	6 (2.85)
Positive/positive	12 (5.71)	3 (1.42)
<b>Child-Pugh grade</b>		
A	124 (59.04)	-
B	46 (21.90)	-
C	40 (19.04)	-

Abbreviations: HBsAg = hepatitis B surface antigen; anti-HCV = antibodies to hepatitis C.

of HBsAg or anti-HCV was found in 89.05% of cirrhotic patients. The frequency distributions of Child-Pugh grades A, B, and C in cirrhotic patients were 59.04%, 21.90%, and 19.04%, respectively.

Among patients with cirrhosis, we compared the ages of beginning the habit of chewing betel quid, alcohol drinking,

and smoking. There was no significant difference among median age of beginning betel quid chewing (median, 34 yr; range, 11-60 yr), alcohol drinking (median, 33 yr; range, 16-63 yr), and smoking (median, 34 yr; range, 11-56 yr).

Among controls, there was a significant difference in the frequency of habitual alcohol drinkers between those chewing betel quid (5/11, 45.45%) and those not chewing betel quid (19/199; 9.54%;  $p = 0.001$ ). The frequency of habitual smokers in betel quid chewers (10/11, 90.91%) was also higher than that in betel quid non-users (66/199; 33.16%;  $p = 0.0002$ ).

**Univariate and Multivariate Analyses of Risk Factors for Cirrhosis**

The prevalence of habitual betel quid chewing, HBsAg, and anti-HCV in cases (16.19%, 66.19%, and 28.57%, respectively) was significantly higher than that in controls (5.23%, 18.57%, and 4.28%, respectively; each  $p < 0.001$ ). As shown in Table 2, univariate analysis indicated that betel quid chewing, HBsAg-positivity, anti-HCV-positivity, alcohol drinking, and smoking were significant risk factors for cirrhosis, whereas older age (>50 yr), low education level (<10 yr), and history of previous surgery and blood transfusion were not risk factors for cirrhosis. By a conditional logistic regression analysis, only betel quid chewing, HBsAg-positivity, and anti-HCV-positivity were significant independent risk factors for cirrhosis (Table 3). The estimated population-attributable risks for subjects with anti-HCV alone, subjects with HBsAg alone, subjects positive for both anti-HCV and HBsAg, and all betel quid chewers were 20.57%, 51.80%, 4.53%, and 11.60%, respectively.

**Interactive Effect of Betel Quid Chewing and Chronic HBV/HCV Infection on Risk of Cirrhosis**

By using HBsAg-negative, anti-HCV-negative betel quid non-users as a reference group, the risk for cirrhosis

**TABLE 2. Univariate Analysis of Multiple Risk Factors for Cirrhosis**

Risk Factor	Cases (n = 210)	Controls (n = 210)	OR (95% CI)
	No. (%)	No. (%)	
Betel quid chewing	34 (16.19)	11 (5.23)	5.94 (3.01-11.79)
HBsAg	139 (66.19)	39 (18.57)	8.58 (5.47-13.46)
Anti-HCV	60 (28.57)	9 (4.28)	8.93 (4.29-18.57)
Smoking	97 (46.19)	76 (36.19)	1.51 (1.02-2.23)
Alcohol drinking	57 (27.14)	24 (11.43)	2.88 (1.71-4.87)
Blood transfusion	32 (15.23)	22 (10.47)	1.53 (0.86-2.74)
Surgery	65 (30.95)	74 (35.23)	0.82 (0.54-1.23)
Age >50 yr	162 (77.14)	165 (78.57)	0.92 (0.58-1.45)
Education <10 yr	114 (54.29)	97 (46.19)	1.38 (0.94-2.03)

Abbreviations: HBsAg = hepatitis B surface antigen; anti-HCV = antibodies to hepatitis C virus; OR = odds ratio; CI = confidence interval.

1303

TABLE 3. Multivariate Analysis of Risk Factors for Cirrhosis\*

Variables	Coefficient	SE	p Value	OR (95% CI)
Betel quid chewing	1.27	0.47	0.007	3.56 (1.41–8.96)
HBsAg	3.04	0.28	0.0001	20.37 (11.67–35.55)
Anti-HCV	3.44	0.42	0.0001	31.43 (13.70–72.10)

Abbreviations: HBsAg = hepatitis B surface antigen; anti-HCV = antibodies to hepatitis C virus; OR = odds ratio; CI = confidence interval; SE = standard error.

\*Dependent variable: presence of cirrhosis. Independent variables: sex, age >50 yr, HBsAg, anti-HCV, betel quid chewing, alcoholic drinking, smoking, educational level <10 yr, history of surgery and blood transfusion.

increased significantly in subjects with HBsAg alone or subjects with anti-HCV alone, or in patients coinfecting with HBV/HCV infection (Table 4). It is noteworthy that betel quid chewing alone also conferred a significantly higher risk for developing cirrhosis (OR 5.45; 95% CI 1.36–21.23). Among habitual betel quid chewers, the risk for cirrhosis in subjects with HBsAg alone was higher than in those without HBV/HCV infection (OR 14.4; 95% CI 1.82–95.69). Betel quid chewers with anti-HCV alone also had a higher risk for developing cirrhosis compared with subjects without HBV/HCV infection ( $p = 0.024$ , Fishers exact test).

Table 5 displays the interactive effect between betel quid chewing and HCV infection. By using anti-HCV-negative betel quid non-users as a reference group, either betel quid chewing or presence of anti-HCV was an independent risk factor for cirrhosis. The highest OR was found in anti-HCV-positive betel quid chewers. Calculation of synergy index indicated that there was an additive interaction between betel quid chewing and chronic HCV infection. Similarly, the risk for developing cirrhosis was strongly associated with

TABLE 5. Interaction Between Hepatitis C Virus Infection and Betel Quid Chewing on Risk of Cirrhosis

Anti-HCV	Betel Quid Chewing	Cases (n = 210)	Controls (n = 210)	OR* (95% CI)
Negative	No	127	191	1.0
Negative	Yes	49	8	9.21 (4.03–21.83)
Positive	No	23	10	3.45 (1.50–8.08)
Positive	Yes	11	1	16.54 (2.17–89.01)

Abbreviations: anti-HCV = antibodies to hepatitis C virus; OR = odds ratio; CI = confidence interval.

\*Synergy index = 1.45.

the presence of HBsAg and chewing betel quid (Table 6). Moreover, HBsAg-positive betel quid chewers had the highest OR, and a synergy index of 2.76. These results indicate an additive interaction between betel quid chewing and chronic HBV/HCV infection on risk of cirrhosis.

### Characteristics of Betel Quid Chewing in Patients and Controls

All betel quid chewers chewed areca nut. Chewing with betel leaf or unripe betel fruit was strongly associated with increased risk for cirrhosis (Table 7). Chewing betel quid for a duration of more than 20 years was an independent risk factor for developing cirrhosis (OR 6.21; 95% CI 1.97–17.23). Moreover, the longer the duration of betel quid chewing, the higher the risk for developing cirrhosis ( $p$  for trend <0.0001; see Table 7).

The median number of total betel quids consumed in cirrhotic patients (204,400 quids; range, 21,900–849,000 quids) was higher than that in controls (54,750 quids; range, 10,950–548,000 quids) ( $p = 0.0001$ ). There was an increased

TABLE 4. Risk of Cirrhosis Modified by Betel Quid Chewing, Status of Anti-HCV and HBsAg in Cirrhotic Patients Compared with Matched Controls

Betel Quid	Status of anti-HCV	Status of HBsAg	Cases (n = 210)	Controls (n = 210)	OR (95% CI)
Nonuser	Negative	Negative	18	157	1.0
Nonuser	Negative	Positive	109	34	27.19 (14.00–53.41)
Nonuser	Positive	Negative	40	5	71.52 (23.07–238.29)
Nonuser	Positive	Positive	9	3	23.25 (4.95–73.74)
User	Negative	Negative	5	8	5.45 (1.36–21.23)* <sup>1</sup>
User	Negative	Positive	18	2	78.50 (15.47–217.26)*
User	Positive	Negative	8	1	69.77 (7.98–272.28) <sup>1</sup>
User	Positive	Positive	3	1	

Abbreviations: HBsAg = hepatitis B surface antigen; anti-HCV = antibodies to hepatitis C virus; OR = odds ratio; CI = confidence interval.

\* $p = 0.003$  (Fisher exact test).

<sup>1</sup> $p = 0.024$  (Fisher exact test)

<sup>2</sup>Uncalculable.

TABLE 6. Interaction Between Hepatitis B Virus Infection and Betel Quid Chewing on Risk of Cirrhosis

HBsAg	Betel Quid Chewing	Cases (n = 210)	Controls (n = 210)	OR* (95% CI)
Negative	No	58	162	1.0
Negative	Yes	118	37	8.90 (5.39–14.77)
Positive	No	13	9	3.73 (1.37–10.20)
Positive	Yes	21	2	29.32 (6.34–86.95)

Abbreviations: HBsAg = hepatitis B surface antigen; OR = odds ratio; CI = confidence interval.  
\*Synergy index = 2.76.

risk for developing cirrhosis in subjects who consumed more than 100,000 quids (OR 6.10; 95% CI 2.17–18.48). There was a positive linear trend between betel quids consumed and the risk for cirrhosis (p for trend <0.0001; see Table 7).

**Characteristics of Cirrhotic Patients by Betel Quid Chewing Status**

As shown in Table 8, cirrhotic patients who chewed betel quid were predominantly male (OR 9.39; 95% CI 1.24–70.88; p = 0.004) and tended to be Child-Pugh grade B or C (OR 5.23; 95% CI 2.30–11.92; p = 0.0001). Betel quid chewers frequently had habits of smoking (OR 16.02; 95% CI 4.44–44.12; p = 0.0001) and alcohol drinking (OR 8.73; 95% CI 3.88–19.63; p = 0.0001). It is noteworthy that among the 5 betel quid chewers who had cirrhosis without hepatitis,

TABLE 7. Risk of Cirrhosis Based on Characteristics of Betel Quid Chewing

	Cases	Controls	OR (95% CI)
Type of betel quid ingredients			
Non-user	176	199	1.0
Areca nut with betel leaf	21	4	5.93 (1.87–16.65)
Areca nut with betel fruit	11	3	4.14 (1.05–16.10)
Mixed	2	4	0.56 (0.01–3.63)
Duration of chewing*			
Non-user	176	199	1.0
<20 yr	12	7	1.93 (0.69–5.58)
20–30 yr	14	3	5.01 (1.39–18.39)
>30 yr	8	1	9.04 (1.13–67.21)
Total amount consumed (quids × 1,000)*			
Non-user	176	199	1.0
<100	7	6	1.31 (0.38–4.52)
100–200	10	2	5.65 (1.14–26.62)
>200	17	3	6.40 (1.73–20.82)

\*p for trend <0.0001 (Mantel extension test for trend).

TABLE 8. Characteristics of Patients with Cirrhosis by Betel Quid Chewing Status

	Habitual Betel Quid Chewing		p Value*
	Yes (n = 34) No. (%)	No (n = 176) No. (%)	
Age >50 yr	24 (70.58)	138 (78.40)	NS
Male gender	33 (97.05)	137 (77.84)	0.004
Education <10 yr	21 (61.76)	92 (52.27)	NS
Smoking <sup>†</sup>	31 (91.17)	66 (37.50)	0.0001
Alcohol drinking <sup>†</sup>	23 (67.64)	34 (19.31)	0.0001
Child-Pugh B/C <sup>†</sup>	25 (73.52)	61 (34.65)	0.0001
HBsAg-positive	21 (61.76)	118 (67.04)	NS
Anti-HCV-positive	11 (32.35)	49 (27.84)	NS
History of surgery	10 (29.4)	55 (31.25)	NS
Blood transfusion	4 (11.8)	28 (15.91)	NS

HBsAg = hepatitis B surface antigen; anti-HCV = antibodies to hepatitis C virus; OR = odds ratio; CI = confidence interval; NS = nonsignificant.

\*The chi-square test with Yates correction was used to compare proportions.

<sup>†</sup>Multivariate analysis indicated that smoking (OR 13.52), alcohol drinking (OR 4.29), and Child-Pugh grade B or C (OR 5.53) were independent risk factors for habitual betel quid chewing.

3 were habitual alcohol drinkers and 4 were habitual smokers. Multivariate analysis with stepwise logistic regression indicated that habitual smoking (OR 13.52; 95% CI 3.57–51.16; p = 0.0001), alcohol drinking (OR 4.29; 95% CI 1.63–11.29; p = 0.003), and Child-Pugh grade B or C (OR 5.53; 95% CI 2.14–14.25; p = 0.0001) were independent risk factors for habitual betel quid chewing.

**DISCUSSION**

To our knowledge, this is the first case-control study to show the association between betel quid chewing and risk for cirrhosis (see Tables 2 and 3). However, the risk for cirrhosis in betel quid chewers is still significantly lower than that for subjects with single HBV or HCV infection alone (see Table 4). The estimated population-attributable risk also shows this trend. Based on this observation and our previous study<sup>61,62</sup>, although betel quid chewing is a risk factor for cirrhosis, chronic HBV/HCV infection is still the most important risk factor for cirrhosis in this area hyperendemic for hepatotropic viruses (see Table 4). In betel quid chewers without HBV/HCV infection, the association between betel quid chewing and cirrhosis might not be strong. Although the odds ratio was greater than 1, the small number of subjects (5 patients and 8 controls) reduces the certainty of this association (see Table 4).

Since betel quid chewing has never before been shown to be a risk factor for cirrhosis, it is important to validate that

1305

our finding is not due to confounding bias. Betel quid chewing is an island-wide, popular habit of Taiwanese. The prevalence of betel quid chewing in our controls was .5% (see Table 2). Based on data estimated from 1,299 subjects collected from the same community as our study, the prevalence of betel quid chewers was 6% (95% CI 4.6–7.1; inclusive of all ages and sexes)<sup>30</sup>. Another report from the same community indicated that there was a prevalence rate of 6.5% for daily chewers among 511 men, whereas none of 651 women chewed quid daily<sup>8</sup>. The prevalence of betel quid chewing in our control group fell within the 95% CI values of these 2 reports. The prevalence of HBsAg (18.6%) and anti-HCV (4.3%) in our healthy controls showed no significant difference from those in volunteer blood donors<sup>66</sup> or community controls in the same area<sup>61–64,67</sup>. Therefore, our controls might be representative of the general population in this community. On the other hand, previous reports have indicated that male gender and older age were associated with a higher prevalence of betel quid chewing<sup>8,30</sup>. To control for the possible confounding effect of age and sex, we enrolled study subjects by matching and adjusted our results by multivariate analysis. In the current study, cirrhotic patients who chewed betel quid were male predominant. Moreover, there was a close association between habitual betel quid chewing and habitual smoking, alcohol drinking, and more severe liver damage in patients with cirrhosis (see Table 8).

Our results indicate that a person who chewed betel quid was usually also a habitual smoker and alcohol drinker (see Table 8). It is reasonable that betel quid chewing might indeed be merely a marker for greater alcohol or cigarette consumption.

Betel quid chewing is popular island-wide in Taiwan<sup>30</sup>. The habit of betel quid chewing appears to be acquired usually at junior high school between the ages of 12 and 15 years<sup>8</sup>. In the current study, our patients usually began chewing betel quid many years before cirrhosis developed. They began chewing betel quid at a median age of 34 years (range, 11–60 yr). Moreover, although none of our patients began chewing betel quid after the diagnosis of cirrhosis (data not shown), it may be that cirrhotic patients are more likely to chew betel quid.

In the current study, there was no significant difference among the ages when patients with cirrhosis began chewing betel quid, drinking alcohol, or smoking. A report from Taiwan<sup>9</sup> indicated that betel quid chewers were more likely than others to engage in high-risk behaviors that could lead to HBV/HCV infection. It is possible there are other confounders for cirrhosis that we did not study.

Although there was a significant difference in the total amount of betel quid chewing in cirrhotic patients and in controls, there was a large overlap between them. As shown in Table 7, the type of betel quid ingredients, the duration of betel quid chewing, and probably underlying liver disease or

genetic predisposition might explain why healthy people and cirrhotic patients could consume varying quantities of betel quids with such different outcomes.

The pathogenic mechanisms for the association between habitual betel quid chewing and the risk of cirrhosis are largely unknown. Areca nut consumption may modulate the function of the hepatic detoxification system and increase the risk of toxic hepatitis<sup>50,57</sup>. Chronic betel quid feeding in animals causes persistent hepatocyte necroinflammation<sup>50</sup>. In this study, habitual betel quid chewers had more severe liver damage, as evidenced by their significantly higher frequency of being Child-Pugh grade B or C (see Table 8). This observation confirms that episodic necroinflammation with subsequent persistent liver injury is important in inducing cirrhosis<sup>26</sup>. Alternatively, the immunosuppressive action of areca nut may facilitate progression of HBV/HCV-associated chronic liver disease<sup>24,51,52</sup>. On the other hand, fibrosis is an almost invariable part of chronic liver disease regardless of etiology<sup>19,44</sup>. It is the fibrous scarring that leads to architectural distortion and cirrhosis. Concurrent hepatic insult by more than 1 agent, such as HCV and alcohol<sup>4,44</sup> or coinfection with other viruses<sup>19</sup>, is synergistic for the progression of fibrosis. Moreover, oxygen-derived free radicals and other reactive oxygen species have been implicated as important mediators of hepatic fibrogenesis in liver injury<sup>22,68</sup>. These compounds can be found in inflammatory byproducts derived from habitual betel quid chewing<sup>7,35,39–41</sup>, alcoholic liver disease, or chronic HBV/HCV infection<sup>17,21</sup>. Taken together, persistent necroinflammation and progressive hepatic fibrogenesis may contribute, at least in part, to the additive interaction between habitual betel quid chewing and chronic HBV/HCV infection. It would be instructive to know how long the betel quid chewers had been infected with HBV/HCV before developing cirrhosis. It is possible that betel quid accelerates progression of cirrhosis.

Aflatoxins are mycotoxins produced by the fungus *Aspergillus flavus*. This fungus contaminates inappropriately processed and stored food, such as corn, peanuts, and rice, which are stored for prolonged periods under hot, humid conditions. This is a significant problem in less-developed countries within the boundaries of the tropical latitudes including Taiwan<sup>47</sup>. Aflatoxin B1 is the most common aflatoxin contaminant and has been found to be the most hepatotoxic<sup>2,33,47</sup>. It was observed that 37.5% of betel nut samples were infested with *Aspergillus flavus*<sup>46</sup>. Habitual betel quid chewing may be 1 source of aflatoxin B1 ingestion in humans. Since the recognition of the hepatotoxic potential of aflatoxins, initially in poultry and other animals in 1960, aflatoxins have been implicated in the genesis of various forms of liver injury. Acute fatty liver<sup>47</sup> and toxic hepatitis<sup>2,33,48</sup> are some of the more acute variants of presentation, whereas cirrhosis and hepatocellular carcinoma are more chronic manifestations. Aflatoxin B1-induced acute hepatotoxicity in

humans has followed the ingestion of contaminated foods. Cirrhosis has been induced in some animals after repeated exposure to aflatoxins<sup>42</sup>. The role of aflatoxin in the production of cirrhosis in humans remains inconclusive, although suspected in some settings. Unexplained cryptogenic cirrhosis and childhood cirrhosis in developing countries may be attributed in part to aflatoxin toxicity<sup>69</sup>.

Based on the above discussion, we hypothesize that repetitive liver cell injury from oxygen-derived free radicals and other reactive oxygen species generated by habitual betel quid chewing may increase the risk of cirrhosis. This may explain the additive interaction between habitual betel quid chewing and chronic HBV/HCV infection. In conclusion, both betel quid chewing and chronic HBV/HCV infection are independent risk factors for cirrhosis. There is an additive interaction between betel quid chewing and chronic HBV/HCV infection on the risk of cirrhosis. Whether abstinence of betel quid chewing in subjects with chronic HBV/HCV infection decreases the risk for cirrhosis warrants further study.

REFERENCES

1. Becker U, Gronbaek M, Johansen D, Sorensen TI. Lower risk for alcohol-induced cirrhosis in wine drinkers. *Hepatology*. 2002;35:868-875.
2. Bhat RV. Aflatoxin and liver injury. *Trop Gastroenterol*. 1996;17:153-160.
3. Bortolotti F, Jara P, Crivellaro C, Hierro L, Cadrobbi P, Frauca E, Camarena C, De La Vega A, Diaz C, De Moliner L, Noventa F. Outcome of chronic hepatitis B in Caucasian children during a 20-year observation period. *J Hepatol*. 1998;29:184-190.
4. Brechot C, Nalpas B, Feitelson MA. Interaction between alcohol and hepatitis viruses in the liver. *Clin Lab Med*. 1996;16:273-287.
5. Caldwell SH, Oelsner DH, Lezoni JC, Hespeneide EE, Battle EH, Driscoll CJ. Cryptogenic cirrhosis: Clinical characterization and risk factors for underlying disease. *Hepatology*. 1999;29:664-669.
6. Chan HL, Leung NW, Hussain M, Wong ML, Lok AS. Hepatitis B e antigen-negative chronic hepatitis B in Hong Kong. *Hepatology*. 2000;31:763-768.
7. Chen CL, Chi CW, Liu TY. Hydroxyl radical formation and oxidative DNA damage induced by areca quid in vivo. *J Toxicol Environ Health A*. 2002;65:327-336.
8. Chen JW, Shaw JH. A study on betel quid chewing behavior among Kaohsiung residents aged 15 years and above. *J Oral Pathol Med*. 1996;25:140-143.
9. Chen KT, Chen CJ, Fagot-Campagna A, Narayan KM. Tobacco, betel quid, alcohol, and illicit drug use among 13- to 35-year-olds in ILan, rural Taiwan: Prevalence and risk factors. *Am J Public Health*. 2001;91:1130-1134.
10. Corrao G, Torchio P, Zambon A, D'Amicis A, Lepore AR, di Orio F. Alcohol consumption and micronutrient intake as risk factors for liver cirrhosis: A case-control study. *Ann Epidemiol*. 1998;8:154-159.
11. Corrao G, Torchio P, Zambon A, Ferrari P, Arico S, di Orio F. Exploring the combined action of lifetime alcohol intake and chronic hepatotropic virus infections on the risk of symptomatic liver cirrhosis. Collaborative Groups for the Study of Liver Diseases in Italy. *Eur J Epidemiol*. 1998;14:447-456.
12. Corrao G, Zambon A, Torchio P, Arico S, La Vecchia C, di Orio F. Attributable risk for symptomatic liver cirrhosis in Italy. Collaborative Groups for the Study of Liver Diseases in Italy. *J Hepatol*. 1998;28:608-614.
13. del Olmo JA, Serra MA, Rodriguez F, Escudero A, Gilibert S, Rodrigo JM. Incidence and risk factors for hepatocellular carcinoma in 967 patients with cirrhosis. *J Cancer Res Clin Oncol*. 1998;124:560-564.
14. Dieter HH, Schimmelpfennig W, Meyer E, Tabert M. Early childhood cirrhoses (ECC) in Germany between 1982 and 1994 with special consideration of copper etiology. *Eur J Med Res*. 1999;4:233-242.
15. Di Marco V, Lo Iacono O, Camma C, Vaccaro A, Giunta M, Martorana G, Fuschi P, Almasio PL, Craxi A. The long-term course of chronic hepatitis B. *Hepatology*. 1999;30:257-264.
16. Du CL, Wang JD. Increased morbidity odds ratio of primary liver cancer and cirrhosis of the liver among vinyl chloride monomer workers. *Occupation Environ Med*. 1998;55:528-532.
17. Farinati F, Cardin R, Degan P, De Maria N, Floyd RA, Van Thiel DH, Naccarato R. Oxidative DNA damage in circulating leukocytes occurs as an early event in chronic HCV infection. *Free Radic Biol Med*. 1999;27:1284-1291.
18. Fletcher LM, Dixon JL, Purdie DM, Powell LW, Crawford DH. Excess alcohol greatly increases the prevalence of cirrhosis in hereditary hemochromatosis. *Gastroenterology*. 2002;122:281-289.
19. Friedman SL. Hepatitis fibrosis. In: Schiff ER, Sorrell MF, Maddrey WC, eds. *Schiff's disease of the liver*, 8th ed. Philadelphia: Lippincott-Raven, pp 371-385, 1999.
20. Guido M, Fagioli S, Tessari G, Burra P, Leandro G, Boccagni P, Cillo U, Naccarato R, Rugge M. Histology predicts cirrhotic evolution of post transplant hepatitis C. *Gut*. 2002;50:697-700.
21. Hagen TM, Huang S, Curnutte J, Fowler P, Martinez V, Wehr CM, Ames BN, Chisari FV. Extensive oxidative DNA damage in hepatocytes of transgenic mice with chronic active hepatitis destined to develop hepatocellular carcinoma. *Proc Natl Acad Sci U S A*. 1994;91:12808-12812.
22. Houghlum K, Filip M, Witzum JL, Chojkier M. Malondialdehyde and 4-hydroxynonenol protein adducts in plasma and liver of rats with iron overload. *J Clin Invest*. 1990;86:1991-1995.
23. Hsu YS, Chien RN, Yeh CT, Sheen IS, Chiou HY, Chu CM, Liaw YF. Long-term outcome after spontaneous HBeAg seroconversion in patients with chronic hepatitis B. *Hepatology*. 2002;35:1522-1527.
24. Hung SL, Chen YL, Wan HC, Liu TY, Chen YT, Ling LJ. Effects of areca nut extracts on the functions of human neutrophils in vitro. *J Periodontol Res*. 2000;35:186-193.
25. Huo TI, Wu JC, Lee PC, Tsay SH, Chang FY, Lee SD. Diabetes mellitus as a risk factor of liver cirrhosis in patients with chronic hepatitis B virus infection. *J Clin Gastroenterol*. 2000;30:250-254.
26. Idilman R, De Maria N, Colantoni A, Van Thiel DH. Pathogenesis of hepatitis B and C-induced hepatocellular carcinoma. *J Viral Hepatitis*. 1998;5:285-299.
27. Ikeda K, Saitoh S, Suzuki Y, Kobayashi M, Tsubota A, Koida I, Arase Y, Fukuda M, Chayama K, Murashima N, Kumada H. Disease progression and hepatocellular carcinogenesis in patients with chronic viral hepatitis: A prospective observation of 2215 patients. *J Hepatol*. 1998;28:930-938.
28. Jeffers L. Hepatocellular carcinoma: An emerging problem with hepatitis C. *J Natl Med Assoc*. 2000;92:369-371.
29. Kato Y, Hamasaki K, Aritomi T, Nakao K, Nakata K, Eguchi K. Most of the patients with cirrhosis in Japan die from hepatocellular carcinoma. *Oncol Rep*. 1999;6:1273-1276.
30. Ko YC, Chiang TA, Chang SJ, Hsieh SF. Prevalence of betel quid chewing habit in Taiwan and related sociodemographic factors. *J Oral Pathol Med*. 1992;21:261-264.
31. Kobayashi M, Ikeda K, Saitoh S, Suzuki F, Tsubota A, Suzuki Y, Arase Y, Murashima N, Chayama K, Kumada H. Incidence of primary cholangiocellular carcinoma of the liver in Japanese patients with hepatitis C virus-related cirrhosis. *Cancer*. 2000;88:2471-2477.
32. Kondili LA, Tosti ME, Szklo M, Costantino A, Cotichini R, Resuli B, Rapicetta M, Mele A. The relationships of chronic hepatitis and cirrhosis to alcohol intake, hepatitis B and C, and delta virus infection: A case-control study in Albania. *Epidemiol Infect*. 1998;121:391-395.
33. Krishnamachari KA, Bhat RV, Nagarajan V, Tilak TB. Hepatitis due to aflatoxicosis: An outbreak in western India. *Lancet*. 1975;1:1061-1063.
34. Law MG. Modelling the hepatitis C virus epidemic in Australia.

1307

- Hepatitis C Virus Projections Working Group. *J Gastroenterol Hepatol*. 1999;14:1100-1107.
35. Liu TY, Chen CL, Chi CW. Oxidative damage to DNA induced by areca nut extract. *Mutat Res*. 1996;367:25-31.
  36. Muir AJ. The natural history of hepatitis C viral infection. *Semin Gastrointest Dis*. 2000;11:54-61.
  37. Muller T, Schafer H, Rodeck B, Haupt G, Koch H, Bosse H, Welling P, Lange H, Krech R, Feist D, Muhlendahl KE, Bramswig J, Feichtinger H, Muller W. Familial clustering of infantile cirrhosis in Northern Germany: A clue to the etiology of idiopathic copper toxicosis. *J Pediatr*. 1999;135:189-196.
  38. Mureto P, Angelucci E, Lucarelli G. Reversibility of cirrhosis in patients cured of thalassemia by bone marrow transplantation. *Ann Intern Med*. 2002;136:667-672.
  39. Nair UJ, Floyd RA, Nair J, Bussachini V, Friesen M, Bartsch H. Formation of reactive oxygen species and of 8-hydroxydeoxyguanosine in DNA in vitro with betel quid ingredients. *Chem Biol Interact*. 1987;63:157-169.
  40. Nair UJ, Friesen M, Richard I, MacLennan R, Thomas S, Bartsch H. Effect of lime composition on the formation of reactive oxygen species from areca nut extract in vitro. *Carcinogenesis*. 1990;11:2145-2148.
  41. Nair UJ, Nair J, Friesen MD, Bartsch H, Ohshima H. Ortho- and meta-tyrosine formation from phenylalanine in human saliva as a marker of hydroxyl radical generation during betel quid chewing. *Carcinogenesis*. 1995;16:1195-1198.
  42. Newberne PM, Butler WH. Acute and chronic effects of aflatoxin on the liver of domestic and laboratory animals: A review. *Cancer Res*. 1969;29:236-250.
  43. Norton SA. Betel: Consumption and consequences. *J Am Acad Derm*. 1998;38:81-88.
  44. Poynard T, Bedossa P, Opolon P. Nature history of liver fibrosis progression in patients with chronic hepatitis C. *Lancet*. 1997;349:825-832.
  45. Pugh RN, Murray-Lyon IM, Dawson JL, Peitroni MC, Williams R. Transection of the esophagus for bleeding esophageal varices. *Br J Surg*. 1973;60:646-649.
  46. Raisuddin S, Misra JK. Aflatoxin in betel nut and its control by use of food preservatives. *Food Add Contam*. 1991;8:707-712.
  47. Ramkumar D, LaBrecque DR. Drug-induced liver disease and environmental toxins. In: Zakim D, Boyer TD, eds. *Hepatology: A textbook of liver disease*, 4th ed. Philadelphia: Saunders, 2003. pp 755-832.
  48. Rastogi R, Srivastava AK, Srivastava M, Rastogi AK. Hepatocurative effect of picroliv and silymarin against aflatoxin B1 induced hepatotoxicity in rats. *Planta Med*. 2000;66:709-713.
  49. Rothman KJ. *Modern epidemiology*. Boston: Little, Brown, 1986. pp 311-326.
  50. Sarma AB, Chakrabarti J, Chakrabarti A, Banerjee TS, Roy D, Mukherjee D, Mukherjee A. Evaluation of pan masala for toxic effects on liver and other organs. *Food Chem Toxicol*. 1992;30:161-163.
  51. Selvan RS, Selvakumaran M, Rao AR. Influence of arecoline on immune system. II. Suppression of thymus-dependent immune responses and parameter of non-specific resistance after short-term exposure. *Immunopharmacol Immunotoxicol*. 1991;13:281-309.
  52. Shahabuddin S, Rao AR. Effect of arecoline on the humoral and cell mediated immune response in mice. *Indian J Exp Biol*. 1980;18:1493-1494.
  53. Sherlock S, Dooley J. Hepatic cirrhosis. In: *Disease of the liver and biliary system*. Oxford: Blackwell, 2002. pp 365-380.
  54. Sherlock S, Dooley J. Malignant liver tumors. In: *Disease of the liver and biliary system*. Oxford: Blackwell, 2002. pp 537-562.
  55. Shindo M, Ken A, Okuno T. Varying incidence of cirrhosis and hepatocellular carcinoma in patients with chronic hepatitis C responding differently to interferon therapy. *Cancer*. 1999;85:1943-1950.
  56. Simonetti RG, Camma C, Fiorillo F, Politi F, D'Amico G, Pagliaro L. Hepatocellular carcinoma: A worldwide problem and the major risk factors. *Dig Dis Sci*. 1991;36:962-972.
  57. Singh A, Rao AR. Evaluation of the modifying influence of arecanut on the garlic-modulated hepatic detoxication system enzymes, sulfhydryl content, and lipid peroxidation in mice. *Teratog Carcinog Mutagen*. 1995;15:127-134.
  58. Sorensen HT, Friis S, Olsen JH, Thulstrup AM, Mellemkjaer L, Linet M, Trichopoulos D, Vilstrup H, Olsen J. Risk of liver and other types of cancer in patients with cirrhosis: a nationwide cohort study in Denmark. *Hepatology*. 1998;28:921-925.
  59. Tanaka K, Sakai H, Hashizume M, Hirohata T. A long-term followup study on risk factors for hepatocellular carcinoma among Japanese patients with liver cirrhosis. *Jpn J Cancer Res*. 1998;89:1241-1250.
  60. Tanner MS. Role of copper in Indian childhood cirrhosis. *Am J Clin Nutr*. 1998;67(Suppl 5):1074S-81S.
  61. Tsai JF, Chang WY, Jeng JE, Ho MS, Wang LY, Hsieh MY, Chen SC, Tsai JH. Hepatitis C virus infection as a risk factor for nonalcoholic liver cirrhosis in Taiwan. *J Med Virol*. 1993;41:296-300.
  62. Tsai JF, Chang WY, Jeng JE, Ho MS, Lin ZY, Tsai JH. Hepatitis B and C virus infection as risk factors for liver cirrhosis and cirrhotic hepatocellular carcinoma: A case-control study. *Liver*. 1994;14:98-102.
  63. Tsai JF, Jeng JE, Ho MS, Chang WY, Lin ZY, Tsai JH. Hepatitis B and C virus infection as risk factors for hepatocellular carcinoma in Chinese: A case-control study. *Int J Cancer*. 1994;56:619-621.
  64. Tsai JF, Jeng JE, Ho MS, Chang WY, Hsieh MY, Lin ZY, Tsai JH. Additive effect modification of hepatitis B surface antigen and e antigen on the development of hepatocellular carcinoma. *Br J Cancer*. 1996;73:1498-1502.
  65. Tsai JF, Jeng JE, Ho MS, Chang WY, Hsieh MY, Lin ZY, Tsai JH. Effect of hepatitis C and B virus infection on risk of hepatocellular carcinoma: A prospective study. *Br J Cancer*. 1997;76:968-974.
  66. Tsai JF, Jeng JE, Ho MS, Wang CS, Chang WY, Hsieh MY, Lin ZY, Tsai JH. Serum alanine aminotransferase level in relation to hepatitis B and C virus infections among blood donors. *Liver*. 1997;17:24-29.
  67. Tsai JF, Jeng JE, Ho MS, Chang WY, Lin ZY, Tsai JH. Independent and additive effect modification of hepatitis C and B viruses infection on the development of chronic hepatitis. *J Hepatol*. 1996;24:271-276.
  68. Tsukamoto H. Oxidative stress, antioxidants, and alcoholic liver fibrogenesis. *Alcohol*. 1993;10:465-467.
  69. Zimmerman HJ. Drug-induced liver disease. In: Schiff ER, Sorrelle MF, Maddrey WC, eds. *Schiff's disease of the liver*, 8th ed. Philadelphia: Lippincott-Raven, 1999. pp 973-1064.

## Risk of betel quid chewing on the development of liver cirrhosis: a community-based case-control study.

Hsiao TJ, Liao HW, Hsieh PS, Wong RH.

Department of Public Health, College of Health Care and Management, Chung Shan Medical University, Taichung, Taiwan.

### Abstract

**PURPOSE:** The role of betel quid on the development of liver cirrhosis is unclear; we thus designed a community-based case-control study to evaluate the association between betel quid chewing and liver cirrhosis.

**METHODS:** A total of 42 cases of liver cirrhosis and 165 matched controls were included for analysis. Questionnaires were administered to obtain histories of betel quid chewing, alcohol consumption, smoking, and family history of liver disease. Hepatitis B surface antigen and anti-hepatitis C antibody were also determined by immunoassay.

**RESULTS:** Individuals with more betel quid chewing (more than 55 quid-years vs. less than 55 quid-years and never-chewers, matched odds ratio [OR(m)] = 2.2; 95% confidence interval [CI]: 1.0-5.0) had higher risks for liver cirrhosis. The combined effects on liver cirrhosis by betel quid chewing and the number of other risk factors, including hepatitis B virus (HBV) infection, smoking, and alcohol drinking, were also observed. When individuals with less betel quid chewing (less than 55 quid-years and never-chewers) and with no other risk factors used as a reference, betel quid chewers expressing greater betel quid chewing (more than 55 quid-years) and more risk factors of HBV infection, cigarette smoking, and habitual alcohol drinking expressed a greater risk of liver cirrhosis (OR(m) = 70.8; 95% CI: 4.0-1260.1).

**CONCLUSIONS:** Our results suggest that betel quid chewing may play an important role in the development of hepatic cirrhosis. Larger study and cohort studies would be necessary to provide further evidence regarding this finding.

## Association between betel-nut chewing and chronic kidney disease in men

Che-Yi Chou<sup>1</sup>, Shi-Yann Cheng<sup>2</sup>, Jiung-Hsiun Liu<sup>1</sup>, Wen-Chun Cheng<sup>3,\*</sup>, I-Min Kang<sup>4</sup>, Yu-Hsiang Tseng<sup>3</sup>, Chuen-Ming Shih<sup>3</sup> and Walter Chen<sup>3</sup>

<sup>1</sup>Division of Nephrology, Department of Internal Medicine, China Medical University Hospital, Taichung, Taiwan, Republic of China; <sup>2</sup>Obstetrics and Gynecology, China Medical University Beigang Hospital, Taiwan, Republic of China; <sup>3</sup>Department of Internal Medicine, China Medical University Beigang Hospital, No. 123 Sinda Road, Beigang Township, Yunlin County, 65152 Taiwan, Republic of China; <sup>4</sup>Department of Family Medicine, China Medical University Beigang Hospital, Taiwan, Republic of China

Submitted 3 April 2007; Accepted 19 May 2008; First published online 23 July 2008

### Abstract

**Background:** Betel-nut use is associated with metabolic syndrome and obesity. However, the association between betel-nut chewing and risk for chronic kidney disease (CKD) is unknown. The present study was conducted to determine the association between betel-nut chewing and CKD in men.

**Methods:** We retrospectively reviewed health-check records of 3264 men in a hospital-based cross-sectional screening programme from 2003 to 2006. CKD was defined as estimated glomerular filtration rate less than 60 ml/min/1.73 m<sup>2</sup> calculated by the Modification of Diet in Renal Disease formula. Risk factors for CKD including diabetes, hypertension, BMI, smoking, alcohol consumption and age were also considered.

**Results:** A total of 677 (20.7%) men were found to have CKD and 427 (13.1%) participants reported a history of betel-nut use. The prevalence (24.8%) of CKD in betel-nut users was significantly higher than that (11.3%) of participants without betel-nut use ( $P=0.026$ ). In multivariate logistic regression analysis with adjustments for age, hypertension, diabetes and hyperlipidaemia, betel-nut use was independently associated with CKD ( $P<0.001$ ). The adjusted odds ratio for betel-nut use was 2.572 (95% CI 1.917, 3.451).

**Conclusions:** Betel-nut use is associated with CKD in men. The association between betel-nut use and CKD is independent of age, BMI, smoking, alcohol consumption, hypertension, diabetes and hyperlipidaemia.

### Keywords

Betel nut  
Body mass index  
Chronic kidney disease  
Diabetes  
Hypertension  
Men  
Metabolic syndrome

The incidence of end-stage renal disease (ESRD) is high and growing rapidly in adults younger than 65 years of age in Taiwan<sup>(1)</sup>. Outcomes of ESRD treatment tend to be poor; however, the cost of treatment is relatively high<sup>(2,3)</sup>. Early detection of possible risk factors and early treatment of chronic kidney disease (CKD) may not only slow the decline of renal function, but also prevent the development of severe cardiovascular complications<sup>(4)</sup>. Apart from well-known risk factors for CKD including age, hypertension, diabetes, obesity and metabolic syndrome, the identification of other possible risk factors associated with CKD is a key for early detection and treatment as well. The prevalence of betel-nut use is about 10%, with about 600 million users all over the world<sup>(5,6)</sup>, and most betel-nut chewers in Taiwan are male. The prevalence of betel-nut use is rising gradually in Taiwan, especially in rural areas<sup>(5)</sup>. Evidence has shown that betel-nut chewing is associated with oral cancer<sup>(7)</sup>, hyperglycaemia, obesity,

metabolic syndrome<sup>(8)</sup> and increase in urinary albumin excretion<sup>(9)</sup>. Betel-nut chewing may be a risk factor for CKD. However, the association between betel-nut chewing and CKD is unknown. We conducted the present cross-sectional retrospective study to determine the association between betel-nut chewing and CKD in Taiwanese men.

### Methods

A total of 8027 (3264 men and 4763 women) records in a general health-check programme in China Medical University Beigang Hospital, Yunlin County, Taiwan, were reviewed from 2003 to 2006. The prevalence of betel-nut use (as chews of fresh *Areca catechu* nuts with *Piper betle* leaves and lime) was 13.8% in men and 0.8% in women. In view of the lower prevalence of betel-nut use in women, data analysis was limited to 3264 men. CKD was

\*Corresponding author. Email d0931662451@yahoo.com.tw

defined as estimated glomerular filtration rate (eGFR) of less than 60 ml/min/1.73 m<sup>2</sup> calculated by the Modification of Diet in Renal Disease formula<sup>(4)</sup>. Basic data on the participants included age, body height, body weight, systolic blood pressure (SBP) and diastolic blood pressure (DBP). Hb, platelet count, blood urea nitrogen (BUN), creatinine, uric acid, aspartate aminotransferase (AST), alanine aminotransferase (ALT), albumin, globulin, cholesterol, TAG and fasting blood sugar were measured standard automated technology. Participants fasted for 12 h overnight before blood sampling in the morning. Data on lifestyle factors and habits were obtained using a questionnaire based on the National Health Institute of Taiwan standard health-check format<sup>(10)</sup>. Hypertension was defined as blood pressure of at least 140/90 mmHg or the use of antihypertensive medication<sup>(11)</sup>. Diabetes mellitus was defined as fasting blood glucose level of 140 mg/dl, non-fasting glucose of 200 mg/dl or a history of treatment for diabetes<sup>(12)</sup>. Smoking was defined as a history of smoking for more than 2 pack-years<sup>(13)</sup>. Alcohol consumption was defined in those people drinking at least one drink daily<sup>(14)</sup>. Hyperlipidaemia was defined as serum cholesterol level  $\geq$ 200 mg/dl, serum TAG  $\geq$ 200 mg/dl or if lipid-lowering agents were being used. Betel chewing

was categorized as never, sometimes or frequently in the last 6 months.

### Statistical analyses

Data are reported as mean and standard deviation or frequency and percentage, as appropriate. Baseline characteristics and anthropometric factors were compared between patients with CKD and those without by Student's *t* test or the Mann-Whitney *U* test (as appropriate) for continuous variables and by the  $\chi^2$  test for categorical variables. Logistic regression models were used to estimate the odds ratios for CKD. To determine associations between betel-nut use and CKD, a multivariate logistic regression model with adjustments for age, sex, hypertension and diabetes was used.  $P < 0.05$  was considered statistically significant. All calculations were carried out using the SPSS for Windows statistical software package version 12 (SPSS Inc., Chicago, IL, USA).

### Results

A total of 677 (20.7%) participants were found to have CKD and 427 (13.1%) participants had a history of

**Table 1** Demographic and biochemical data of study participants by chronic kidney disease (CKD) status: retrospective review of health-check records of 3264 men in a hospital-based cross-sectional screening programme, Yunlin County, Taiwan, 2003 to 2006

	Overall		CKD(-) (n 2587)		CKD(+) (n 677)	
	Mean	SD	Mean	SD	Mean	SD
Age (years)	64.5	11.6	62.7	11.6	71.7*	8.3
eGFR (ml/min/1.73 m <sup>2</sup> )	74.5	19.6	81.0	16.0	49.0*	11.0
BMI (kg/m <sup>2</sup> )	24.8	3.3	24.8	3.4	24.5*	3.2
Height (cm)	164.1	6.4	164.2	6.5	163.9	5.9
Weight (kg)	66.8	10.4	67.0	10.4	66.0*	10.0
SBP (mmHg)	134	23	132	22	141*	24
DBP (mmHg)	78	13	78	12	79	14
Hb (g/dl)	14.6	1.4	14.7	1.3	14.0*	1.7
Platelets (10 <sup>3</sup> / $\mu$ l)	199	56	200	56	191	55
AST (IU/l)	34	29	34	31	33	22
ALT (IU/l)	35	49	36	53	32*	33
BUN (mg/dl)	18	7	17	5	24*	10
Creatinine (mg/dl)	1.1	0.4	1.0	0.1	1.6*	0.7
Uric acid (mg/dl)	6.5	1.5	6.3	1.4	7.4*	1.6
Albumin (g/dl)	4.0	0.3	4.0	0.3	3.9*	0.4
Globulin (g/dl)	3.2	0.5	3.2	0.5	3.3	0.5
Cholesterol (mg/dl)	194	39	194	40	195	40
TAG (mg/dl)	129	138	129	143	129	82
Fasting blood glucose (mg/dl)	113	46	113	46	111	45
	<i>n</i>	%	<i>n</i>	%	<i>n</i>	%
Co-morbidity						
Hypertension	749	22.9	501	19.4	248	36.6*
Diabetes	406	12.4	304	11.5	102	15.1*
Hyperlipidaemia	127	3.9	101	3.9	26	3.8
Lifestyle						
Smoking	855	26.2	792	30.6	166	24.5*
Alcohol consumption	958	29.4	746	28.8	109	16.1*
Betel-nut use	427	13.1	321	12.4	106	15.7*

eGFR, estimated glomerular filtration rate by Modification of Diet in Renal Disease formula; SBP, systolic blood pressure; DBP, diastolic blood pressure; AST, aspartate aminotransferase; ALT, alanine aminotransferase; BUN, blood urea nitrogen.

\* $P < 0.05$  v. CKD(-) in independent *t* test, Mann-Whitney *U* test or  $\chi^2$  test.

**Table 2** Demographic and biochemical data of participants by history of betel-nut use: retrospective review of health-check records of 3264 men in a hospital-based cross-sectional screening programme, Yunlin County, Taiwan, 2003 to 2006

	Betel nut(-) (n 2837)		Betel nut(+) (n 427)	
	Mean	sd	Mean	sd
Age (years)	65.2	11.3	59.8*	12.2
eGFR (ml/min/1.73 m <sup>2</sup> )	75.0	19.0	74.0	21.0
BMI (kg/m <sup>2</sup> )	24.7	3.3	25.3*	3.2
Height (cm)	164.0	6.0	165.0	6.0
Weight (kg)	66.5	10.3	68.8*	10.4
SBP (mmHg)	134	23	131*	22
DBP (mmHg)	78	13	78	13
Hb (g/dl)	14.6	1.4	14.7	1.5
Platelets (10 <sup>3</sup> /μl)	198	55	201	59
AST (IU/l)	33	30	37*	27
ALT (IU/l)	35	52	38	34
BUN (mg/dl)	18	6	19	9
Creatinine (mg/dl)	1.1	0.4	1.1	0.7
Uric acid (mg/dl)	6.5	1.5	6.4	1.5
Albumin (g/dl)	4.0	0.3	4.0	0.4
Globulin (g/dl)	3.2	0.5	3.2	0.5
Cholesterol (mg/dl)	194	39	191	41
TAG (mg/dl)	123	99	166*	259
Fasting blood glucose (mg/dl)	112	45	118*	43
	n	%	n	%
Chronic kidney disease	321	11.3	106	24.8*
Co-morbidity				
Hypertension	664	23.4	85	19.9
Diabetes	356	12.5	50	11.7
Hyperlipidaemia	113	4.0	14	3.1
Lifestyle				
Smoking	661	23.3	297	69.6*
Alcohol consumption	624	22.0	231	54.1*

eGFR, estimated glomerular filtration rate by Modification of Diet in Renal Disease formula; SBP, systolic blood pressure; DBP, diastolic blood pressure; AST, aspartate aminotransferase; ALT, alanine aminotransferase; BUN, blood urea nitrogen.

\* $P < 0.05$  v. betel nut(-) in independent *t* test, Mann-Whitney *U* test or  $\chi^2$  test.

betel-nut use. The prevalence of CKD was significantly higher in participants with betel-nut use than in those without (24.8% v. 11.3%,  $P = 0.026$ ). The demographic data and biochemical characteristics of the entire male study group are shown in Table 2. As can be seen, participants with CKD were significantly older and had higher SBP, serum BUN, creatinine and uric acid levels than participants without CKD. The prevalence of hypertension, diabetes and betel-nut chewing was significantly higher in CKD participants than non-CKD participants. Hb, ALT and albumin levels were significantly lower in participants with CKD than in those without.

The prevalence of CKD was 24.8% (106/427) in betel-nut users, which was significantly higher than that (11.3%, 321/2837) of non-users. As shown in Table 2, the participants with betel-nut use were younger and had lower SBP than those without. Serum TAG and fasting blood glucose levels were significantly higher in participants with betel-nut use than those without. In addition, participants with betel-nut use also had higher prevalence of smoking and alcohol usage. The unadjusted OR of

**Table 3** Unadjusted odds ratios and 95% confidence intervals for association of chronic kidney disease with various risk factors in univariate logistic regression analysis: retrospective review of health-check records of 3264 men in a hospital-based cross-sectional screening programme, Yunlin County, Taiwan, 2003 to 2006

	OR	95% CI	P
Hypertension	2.407	2.002, 2.894	<0.001
Diabetes	1.332	1.046, 1.697	0.020
Smoking	0.736	0.606, 0.894	0.002
Alcohol consumption	0.474	0.379, 0.591	<0.001
Betel-nut use	1.310	1.033, 1.663	0.026
Hypertension + betel-nut use	2.766	1.781, 4.297	<0.001
Diabetes + betel-nut use	1.993	1.104, 3.601	0.022

**Table 4** Odds ratios and 95% confidence intervals for association of chronic kidney disease with various risk factors in multivariate logistic regression analysis after adjustment for age, hypertension and diabetes: retrospective review of health-check records of 3264 men in a hospital-based cross-sectional screening programme, Yunlin County, Taiwan, 2003 to 2006

	OR	95% CI	P
Betel-nut use	2.572	1.917, 3.451	<0.001
BMI*	1.008	0.979, 1.037	0.61
Smoking	1.007	0.799, 1.270	0.950
Hyperlipidaemia	1.055	0.651, 1.709	0.827
Alcohol consumption	0.786	0.609, 1.015	0.064

\*OR calculated per 1 kg/m<sup>2</sup> increment.

CKD for traditional risk factors in univariate logistic regression analyses are shown in Table 3. Hypertension and diabetes were associated with increased CKD risk: OR = 2.407 (95% CI 2.002, 2.894,  $P < 0.001$ ) and OR = 1.332 (95% CI 1.046, 1.697,  $P = 0.020$ ), respectively. For the individuals with hypertension and betel-nut use, the OR for CKD increased to 2.766 (95% CI 1.781, 4.297,  $P < 0.001$ ). For participants with diabetes and betel-nut use, the OR for CKD was 1.993 (95% CI 1.104, 3.601,  $P = 0.022$ ). These findings suggest the synergic effect of betel-nut use on CKD risk in patients with diabetes or hypertension.

Risk factors for CKD including smoking, alcohol consumption, BMI and hyperlipidaemia were taken into consideration in multivariate logistic regression analyses with adjustments for age, hypertension and diabetes. As shown in Table 4, betel-nut use, independent of BMI, hyperlipidaemia, smoking or alcohol consumption, was significantly associated with CKD ( $P < 0.001$ ). The adjusted OR for betel-nut use was 2.572 (95% CI 1.917, 3.451), suggesting that betel-nut use may be a more important CKD risk factor than alcohol consumption, smoking, BMI or hyperlipidaemia.

## Discussion

We found that exposure to betel nut was independently associated with CKD in men based on the data of a

hospital-based health-check programme. This postulate was supported by three findings: (i) participants with a history of betel-nut use had a higher prevalence of CKD than those without; (ii) betel-nut use was independently associated with a 2.6-fold increased risk of CKD after adjustment for age, hypertension and diabetes, and the association was independent of BMI, smoking, alcohol consumption and hyperlipidaemia; and (iii) the use of betel nut increased further the risk for CKD in individuals with diabetes or hypertension.

Betel-nut use, an established risk factor for oropharyngeal malignancy, is associated with hyperglycaemia, obesity and metabolic syndrome<sup>(8)</sup>. Our finding may be explained by several hypotheses. First, the aqueous extract of betel nut can induce breaks in DNA of kidney cells in an animal model<sup>(15)</sup>. A decreased eGFR has been reported for a subject who regularly consumed about 40 betel nuts/d<sup>(16)</sup>. Second, participants with betel-nut use have a high prevalence of smoking<sup>(17)</sup> and alcohol consumption<sup>(18)</sup> that are themselves risk factors for CKD. The result of multivariate logistic regression analysis (Table 4) suggested that the influence of betel-nut may overpower the influence of smoking and alcohol consumption. Third, betel-nut use is associated with metabolic syndrome and obesity<sup>(19,20)</sup> which are important risk factors for CKD. It is possible that the use of betel nut is associated with CKD through the influence of metabolic syndrome or obesity<sup>(8,21)</sup>. Betel-nut users had higher serum TAG and fasting blood sugar (Table 2) than non-users; however, the data on HDL and waist circumferences were not available in our study. In view of the effect of CKD on global health, our finding had an important epidemiological implication.

The prevalence of CKD was 20.7% in our study (age-corrected prevalence 13.8%), higher than the previous reported prevalence of CKD among the general population in Taiwan<sup>(1,22)</sup>. Participants in the present study were older than the general population so they might be more at risk for CKD. Nevertheless, the prevalence of betel-nut chewing in our study is close to previous community-based cohort data<sup>(8,21)</sup>. In addition, participants with betel-nut use had lower SBP than those without, which may be explained by the peripheral cholinergic effect of betel nut and by the relatively younger age of betel-nut chewers.

In conclusion, our study demonstrates a significant association between betel-nut use and CKD in men and this association is independent of age, hypertension, diabetes, BMI, smoking, alcohol consumption and hyperlipidaemia. More studies are needed to confirm our findings and prospective studies are needed to investigate the effect of cessation of betel-nut use in CKD.

#### Acknowledgements

We have no conflicts for this study. We received no funding for this study.

**Author contributions:** C.-Y.C. – entire text; S.-Y.C., J.-H.L. and W.-C.C. – co-authors of text and editorial revision; I.-M.K. and C.-M.S. – data collection and analysis; W.C and Y.-H.T. – supervision of the study and writing.

#### References

1. Kuo HW, Tsai SS, Tiao MM & Yang CY (2007) Epidemiological features of CKD in Taiwan. *Am J Kidney Dis* **49**, 46–55.
2. Yang WC, Hwang SJ, Chiang SS, Chen HF & Tsai ST (2001) The impact of diabetes on economic costs in dialysis patients: experiences in Taiwan. *Diabetes Res Clin Pract* **54**, Suppl. 1, S47–S54.
3. Lysaght MJ (2002) Maintenance dialysis population dynamics: current trends and long-term implications. *J Am Soc Nephrol* **13**, Suppl. 1, S37–S40.
4. National Kidney Foundation (2002) K/DOQI clinical practice guidelines for chronic kidney disease: evaluation, classification, and stratification. *Am J Kidney Dis* **39**, S1–S266.
5. Gupta PC & Warnakulasuriya S (2002) Global epidemiology of areca nut usage. *Addict Biol* **7**, 77–83.
6. IARC Working Group on the Evaluation of Carcinogenic Risks to Humans (2004) Betel-quid and areca-nut chewing and some areca-nut derived nitrosamines. *IARC Monogr Eval Carcinog Risks Hum* **85**, 1–334.
7. Ho PS, Ko YC, Yang YH, Shieh TY & Tsai CC (2002) The incidence of oropharyngeal cancer in Taiwan: an endemic betel quid chewing area. *J Oral Pathol Med* **31**, 213–219.
8. Yen AM, Chiu YH, Chen LS, Wu HM, Huang CC, Boucher BJ & Chen TH (2006) A population-based study of the association between betel-quid chewing and the metabolic syndrome in men. *Am J Clin Nutr* **83**, 1153–1160.
9. Tseng C-H (2006) Betel nut chewing is independently associated with urinary albumin excretion rate in type 2 diabetic patients. *Diabetes Care* **29**, 462–463.
10. Huang YG, Tseng HM & Luo JC (2002) Findings of anthropometric and laboratory data from adult health screening under the National Health Insurance plan in Taiwan. *Chang Gung Med J* **25**, 29–38.
11. Hyman DJ & Pavlik VN (2001) Characteristics of patients with uncontrolled hypertension in the United States. *N Engl J Med* **345**, 479–486.
12. Hwang SJ, Ballantyne CM, Sharrett AR, Smith LC, Davis CE, Gotto AM Jr & Boerwinkle E (1997) Circulating adhesion molecules VCAM-1, ICAM-1, and E-selectin in carotid atherosclerosis and incident coronary heart disease cases: the Atherosclerosis Risk In Communities (ARIC) study. *Circulation* **96**, 4219–4225.
13. Schachinger V, Britten MB & Zeiher AM (2000) Prognostic impact of coronary vasodilator dysfunction on adverse long-term outcome of coronary heart disease. *Circulation* **101**, 1899–1906.
14. Gignoux I, Gagnon J, St-Pierre A, Cantin B, Dagenais GR, Meyer F, Despres JP & Lamarche B (2006) Moderate alcohol consumption is more cardioprotective in men with the metabolic syndrome. *J Nutr* **136**, 3027–3032.
15. Wary KK & Sharan RN (1988) Aqueous extract of betel-nut of north-east India induces DNA-strand breaks and enhances rate of cell proliferation *in vitro*. Effects of betel-nut extract *in vitro*. *J Cancer Res Clin Oncol* **114**, 579–582.
16. Lin S-H, Lin Y-F, Cheema-Dhadli S, Davids MR & Halperin ML (2002) Hypercalcaemia and metabolic alkalosis with

- betel nut chewing: emphasis on its integrative pathophysiology. *Nephrol Dial Transplant* **17**, 708-714.
17. Stengel B, Tarver-Carr ME, Powe NR, Eberhardt MS & Brancati FL (2003) Lifestyle factors, obesity and the risk of chronic kidney disease. *Epidemiology* **14**, 479-487.
  18. Shankar A, Klein R & Klein BE (2006) The association among smoking, heavy drinking, and chronic kidney disease. *Am J Epidemiol* **164**, 263-271.
  19. Chung FM, Chang DM, Chen MP, Tsai JC, Yang YH, Shieh TY, Shin SJ, Chen TH, Tai TY & Lee YJ (2006) Areca nut chewing is associated with metabolic syndrome: role of tumor necrosis factor- $\alpha$ , leptin, and white blood cell count in betel nut chewing-related metabolic derangements. *Diabetes Care* **29**, 1714.
  20. Chen TH, Chiu YH & Boucher BJ (2006) Transgenerational effects of betel-quin chewing on the development of the metabolic syndrome in the Keelung Community-based Integrated Screening Program. *Am J Clin Nutr* **83**, 688-692.
  21. Chang WC, Hsiao CF, Chang HY, Lan TY, Hsiung CA, Shih YT & Tai TY (2006) Betel nut chewing and other risk factors associated with obesity among Taiwanese male adults. *Int J Obes (Lond)* **30**, 359-363.
  22. Hsu CC, Hwang SJ, Wen CP, Chang HY, Chen T, Shiu RS, Horng SS, Chang YK & Yang WC (2006) High prevalence and low awareness of CKD in Taiwan: a study on the relationship between serum creatinine and awareness from a nationally representative survey. *Am J Kidney Dis* **48**, 727-738.

1314

# Association Between Betelnut Chewing and Chronic Kidney Disease in Adults

I-Min Kang, MD  
Che-Yi Chou, MD  
Yu-Hsiung Tseng, MD  
Chiu-Ching Huang, MD  
Wen-Yu Ho  
Chuen-Ming Shih, MD  
Walter Chen, MD

**Objective:** This study was conducted to access the association between betelnut chewing and chronic kidney disease (CKD) in adults. **Methods:** We retrospectively reviewed 3552 participants (1418 men and 2134 women) younger than 65 in this hospital-based cross-sectional study from 2003 to 2006. **Results:** A total of 198 (5.6%) participants were found to have CKD and 287 (8.1%) participants (268 male and 19 female) reported a history of betelnut use. The prevalence (9.4%) of CKD in betelnut users was significantly higher than that (5.2%) of participants without betelnut use ( $P = 0.003$ ). In multivariate logistic regression with adjustment for age, sex, hypertension, and diabetes, betelnut use and body mass index were independently associated with CKD ( $P = 0.026$  and  $P = 0.038$ ). **Conclusions:** Betelnut use is associated with chronic kidney disease in adults younger than 65. (J Occup Environ Med. 2007;49:776-779)

The incidence of end-stage renal disease (ESRD) is high and is growing rapidly in adults younger than 65 in Taiwan.<sup>1</sup> Outcomes of ESRD treatment tend to be poor; however, the cost of treatment is relatively high.<sup>2,3</sup> Early detection of possible risk factors and early treatment of chronic kidney disease (CKD) may not only slow the decline of renal function but also prevent the development of severe cardiovascular complications.<sup>4</sup> In addition to well-known risk factors of CKD, including age, hypertension, diabetes, obesity, and metabolic syndrome, identifying possible risk factors associated with CKD is a key to early detection and treatment. The prevalence of betelnut use is about 10%, 240 million, in Taiwan and it is rising gradually, in the country area in particular.<sup>5</sup> Evidence has shown that betelnut chewing is associated with oral cancer,<sup>6</sup> hyperglycemia, obesity, metabolic syndrome,<sup>7</sup> and increase of urinary albumin excretion.<sup>8</sup> Therefore, betelnut chewing might be a risk factor for CKD. However, the association between betelnut chewing and CKD is unknown. We conducted this retrospective study to determine the association between betelnut chewing and CKD in adults.

From the Department of Family Medicine (Drs Kang, Shih, and Chen), China Medical University Beigang Hospital, Yunlin, Taiwan; Division of Nephrology (Drs Chou and Tseng), Department of Internal Medicine, China Medical University Beigang Hospital, YunLin, Taiwan; Division of Nephrology (Dr Huang), Department of Internal Medicine, China Medical University Hospital, Taichung, Taiwan; Department of Laboratory Medicine (Ho), China Medical University Beigang Hospital, YunLin, Taiwan.

Address correspondence to: Che-Yi Chou MD, Division of Nephrology Department of Internal Medicine, China Medical University Beigang Hospital, No.123, Sinda Rd., Beigang Township, Yunlin County 65152, Taiwan; E-mail: cychou.chou@gmail.com

Copyright © 2007 by American College of Occupational and Environmental Medicine

DOI: 10.1097/JOM.0b013e318095a48a

## Materials and Methods

We reviewed the records of 3552 participants (1418 men and 2134 women) of a general health-check program, who were younger than 65 years old in China Medical University Beigang Hospital from 2003 to 2006. CKD was defined as an estimated glomerular filtration rate of

less than 60 mL/min/1.73 m<sup>2</sup> calculated by the Modification of Diet in Renal Disease formula.<sup>4</sup> Basic data of the participants including age, gender, body height, body weight, systolic blood pressure (SBP), diastolic blood pressure (DBP), hemoglobin, platelet count, blood urea nitrogen (BUN), creatinine, uric acid, aspartate aminotransferase (AST), alanine aminotransferase (ALT), albumin, globulin, cholesterol, triglyceride, and fasting blood glucose were measured. Participants fasted for 12 hours overnight before blood samples were collected in the morning. Hypertension was defined as a blood pressure of at least 140/90 mm Hg or the use of antihypertensive medication.<sup>9</sup> Diabetes mellitus was defined as a fasting blood glucose level of 140 mg/dL, non-fasting glucose of 200 mg/dL, or a history of treatment for diabetes.<sup>10</sup> Smoking was defined as a history of smoking for more than 2 pack-years.<sup>11</sup> Alcohol consumption was defined as drinking at least one drink a day.<sup>12</sup> Hyperlipidemia was defined as a serum cholesterol level  $\geq 200$  mg/dL, a serum triglyceride level  $\geq 200$  mg/dL, or if lipid-lowering agents were being used.

### Statistical Analysis

Data are reported as mean  $\pm$  SD, median, or percent frequency, as appropriate. The baseline characteristics and anthropometric factors were compared between patients with CKD and those without by independent *t* test or Mann-Whitney *U* test for continuous variables and by  $\chi^2$  test for categorical variables. Logistic regression models were used to estimate the odds ratios (ORs) for CKD. To determine associations between possible risk factors and CKD, a multivariate logistic regression model with adjustment for age, sex, hypertension, and diabetes was used. A *P* < 0.05 was considered statistically significant. All calculations were carried out using a standard statistical package (SPSS for Windows, version 12, Chicago, IL).

### Results

A total of 198 (5.6%) participants were found to have CKD and 287 (8.1%) participants reported a history of betelnut use. The prevalence of CKD was significantly higher in betelnut users than in non-betelnut users (9.4% and 5.2%, *P* = 0.003). The demographic data and biochemical characteristics of the entire study group, participants by CKD, and by betelnut use are shown in Table 1. The incidence of CKD was significantly higher in men than in women (7.1% versus 4.5%, *P* = 0.001). Participants with CKD were significantly older and had a higher BMI. The prevalence of hypertension, diabetes, hyperlipidemia, and betelnut use was significantly higher in CKD participants. The blood urea nitrogen, creatinine, uric acid, cholesterol, triglyceride, and fasting blood glucose were significantly higher and platelet count, serum albumin levels were significantly lower in participants with CKD than in those without.

The participants with betelnut use were younger and had lower eGFR, globulin, and cholesterol levels. The prevalence of CKD, smoking, and alcohol consumption was significantly higher in participants with betelnut use than in those without (*P* = 0.003, *P* < 0.001, and *P* < 0.001). The betelnut users had higher body weight, SBP, hemoglobin, AST, ALT, creatinine, uric acid, triglyceride, and fasting blood glucose than non-betelnut users did.

The OR of CKD risk factors, including hypertension, diabetes, hyperlipidemia, betelnut, smoking, and alcohol consumption, are shown in Table 2. The OR (95% confidence interval [CI]) of hypertension, diabetes, and betelnut was 2.083 (1.490–2.913), 1.822 (1.183–2.805), and 1.879 (1.228–2.874), respectively. The associations between risk factors of CKD were analyzed with multivariate logistic regression with adjustment for age, gender, hypertension, and diabetes. As shown in Table 3, body mass index and betelnut use

were independently associated with CKD (*P* = 0.038 and *P* = 0.026). The adjusted ORs of betelnut use were 1.812 (95% CI = 1.072–3.061, *P* = 0.026). The adjusted ORs and their 95% CI of possible risk factors are shown in Table 3.

### Discussion

#### Background

Betelnut (Areca nut), a seed of the Betel Palm (Areca catechu), is often chewed for its stimulating effects on the central nervous system. Betelnut chewing, the fourth most addictive habit in the world after nicotine, ethanol, and caffeine use, occurs in >10% of the world population.<sup>5</sup> Betelnut is usually chewed in combination with piper betel leaf and lime, and arecal alkaloid (betel quid). Betelnut chewing is an ancient practice commonly found in many countries of Asia and among migrated communities in Africa, Europe, and North America.<sup>13</sup> The prevalence of betelnut chewing is increasing in Taiwan, especially in adolescent students because of a transgenerational effect.<sup>14</sup> Betelnut use, an established risk factor for oropharyngeal malignancy,<sup>6</sup> has also been found to be associated with hyperglycemia, obesity,<sup>15</sup> and metabolic syndrome<sup>7,16</sup> in recent studies.

#### Data Results

We found that exposure to betelnut was associated with chronic kidney disease in adults younger than 65. This postulate was supported by two findings: 1) participants with a history of betel nut use had a higher prevalence of CKD than did those without (9.4% versus 5.2%, *P* = 0.003). 2) The relative risk of CKD in participants with betelnut use was higher than that in participants with alcohol consumption or smoking (Table 2). As the result of multivariate logistic regression (Table 3) showed, smoking and alcohol consumption were not significantly associated with CKD when betelnut was included in the analysis. These

**TABLE 1**  
Clinical Characteristics

	Overall n = 3552	CKD (-) n = 3354	CKD (+) n = 198	Betelnut (-) n = 3265	Betelnut (+) n = 287
Age (year)	53.6 ± 7.3	53.3 ± 7.3	58.6 ± 5.9*	53.7 ± 7.3	51.8 ± 7.4**
Gender (male/female)	1418/2134	1317/2037	101/97*	1150/2115	268/19**
eGFR	85.4 ± 18.1	87.4 ± 16.5	51.9 ± 9.4*	86 ± 18	83 ± 18**
CKD n (%)	198 (5.6)			25.1 ± 3.7	25.3 ± 3.2
BMI (kg/M <sup>2</sup> )	25.1 ± 3.7	25.1 ± 3.7	26 ± 3.6*	158.6 ± 7.8	165.1 ± 6.5**
Height (cm)	159 ± 7.9	159.1 ± 7.9	160.1 ± 7.6	63.3 ± 10.9	69.1 ± 10.7**
Weight (kg)	63.8 ± 11	63.6 ± 11	66.6 ± 10.8*	124 ± 21	128 ± 21**
SBP (mm Hg)	125 ± 21	124 ± 21	130 ± 20	78 ± 12	79 ± 13
DBP (mm Hg)	78 ± 12	78 ± 12	82 ± 12	171 (5.2)	27 (9.4)**
Comorbidity					
Hypertension, n (%)	518 (14.6)	468 (14)	50 (25.3)*	478 (14.6)	40 (13.9)
Diabetes, n (%)	283 (8)	257 (7.7)	26 (13.1)*	262 (8)	21 (7.3)
Hyperlipidemia, n (%)	128 (3.6)	115 (3.4)	13 (6.6)*	118 (3.6)	10 (3.5)
Lifestyle					
Smoking, n (%)	607 (17.1)	565 (16.8)	42 (21.2)	490 (15)	199 (69.3)**
Alcohol, n (%)	689 (19.4)	641 (19.1)	48 (24.2)	387 (11.9)	220 (67.6)**
Betelnut, n (%)	287 (8.1)	260 (7.8)	27 (13.6)*		
Hemoglobin (g/dL)	13.9 ± 1.5	13.9 ± 1.4	13.8 ± 1.7	13.8 ± 1.4	14.9 ± 1.3**
Platelet (10 <sup>3</sup> /μL)	217 ± 57	217 ± 57	209 ± 63*	218 ± 57	211 ± 58
AST (IU/L)	31 ± 25	31 ± 26	33 ± 22	31 ± 26	37 ± 25**
ALT (IU/L)	33 ± 47	33 ± 48	34 ± 35	33 ± 48	39 ± 32**
BUN (mg/dL)	16 ± 5	15 ± 4.2	23 ± 8*	16 ± 5	16 ± 5
Creatinine (mg/dL)	0.9 ± 0.3	0.8 ± 0.2	1.4 ± 0.8*	0.9 ± 0.2	1 ± 0.6**
Uric acid (mg/dL)	5.7 ± 1.5	5.7 ± 1.4	6.9 ± 1.7*	5.7 ± 1.4	6.4 ± 1.5**
Albumin (g/dL)	4.0 ± 0.3	4 ± 0.3	3.9 ± 0.4*	4 ± 0.3	4 ± 0.3
Globulin (g/dL)	3.2 ± 0.4	3.2 ± 0.4	3.3 ± 0.5	3.2 ± 0.4	3.1 ± 0.5**
Cholesterol (mg/dL)	201 ± 39	200 ± 38	210 ± 43*	201 ± 38	192 ± 43**
Triglyceride (mg/dL)	124 ± 132	123 ± 134	142 ± 99*	119 ± 99	187 ± 316**
Glucose (mg/dL)	108 ± 44	108 ± 42	116 ± 64*	108 ± 43	113 ± 53

Data is expressed as mean ± SD or number (percent), as appropriate.

\**P* < 0.05 in independent *t* test, Mann-Whitney *U* test, or  $\chi^2$  test between participants with CKD and those without.

\*\**P* < 0.05 in independent *t* test, Mann-Whitney *U* test, or  $\chi^2$  test between betelnut chewer and non-betelnut chewer.

eGFR indicates estimated glomerular filtration rate (mL/min/1.73 m<sup>2</sup>); BMI, body mass index; SBP, systolic blood pressure; DBP, diastolic blood pressure; AST, aspartate aminotransferase; ALT, alanine aminotransferase; BUN, blood urea nitrogen.

findings suggested that the influence of betelnut may overpower the influence of smoking and alcohol consumption. 3) Betelnut use was independently associated with a 1.8-fold increased risk of CKD

when adjusted for age, sex, hypertension, and diabetes.

### Possible Mechanism

Our finding may be explained by several hypotheses (Table 4). First, betelnut may have a direct nephro-

toxicity. The aqueous extract of betelnut was found to induce DNA breaks in kidney cells in animal model<sup>17</sup> and betelnut chewing is associated with increasing urine albumin excretion in type 2 diabetic patients.<sup>8</sup> Second, betelnut was asso-

**TABLE 2**  
Odd Ratios of Chronic Kidney Disease (CKD) Risk Factors

	Odds Ratio	95% Confidence Interval
Hypertension	2.083	1.490–2.913
Diabetes	1.822	1.183–2.805
Hyperlipidemia	1.979	1.095–3.579
Betelnut	1.879	1.228–2.874
Smoking	1.329	0.934–1.891
Alcohol consumption	1.354	0.968–1.896

**TABLE 3**  
Odd Ratios (ORs) of Chronic Kidney Disease (CKD) Risk Factors Adjusted for Age, Gender, Hypertension, and Diabetes

	ORs	95% Confidence Interval	<i>P</i>
Betelnut	1.812	1.072–3.061	0.026
BMI	1.043	1.002–1.085	0.038
Hyperlipidemia	1.763	0.952–3.266	0.071
Smoking	1.014	0.639–1.610	0.953
Alcohol consumption	1.195	0.786–1.818	0.405

BMI indicates body mass index (every 1-kg/m<sup>2</sup> increment).

TABLE 4

Possible Mechanism of Betelnut-Related Chronic Kidney Disease (CKD)

Direct nephrotoxicity
Induces DNA breaks in kidney cells (animal model)
Increases urinary albumin excretion rate in type 2 diabetic patients
Through precursor of chronic kidney disease
Diabetes
Obesity
Metabolic syndrome
Combined lifestyle
Smoking
Alcohol consumption

ciated with CKD through the associated lifestyle factors. Participants with betelnut use have a high prevalence of smoking<sup>18</sup> and alcohol consumption,<sup>19</sup> which are risk factors of CKD. Third, betelnut use may be associated with CKD through the precursors of CKD such as diabetes, metabolic syndrome, and obesity.<sup>16,20</sup> Betelnut users were found to have a higher SBP, serum triglyceride, and fasting blood glucose (Table 1) in our study; however, the data of high-density lipoprotein cholesterol and waist circumferences were not available. In view of the effect of CKD on global health, our finding had an important epidemiological implication.

The peak age of betelnut use was reported to be 30 to 40; however, only 34 participants enrolled in our study were younger than 40,<sup>7,15,16</sup> which explained the lower prevalence of betelnut use in our study.<sup>13,21</sup> The prevalence of CKD is 5.6% in this study, similar to previous reported incidences of CKD in adults younger than 65 in Taiwan.<sup>1,22</sup> The incidence of CKD increases rapidly in adults younger than 65 year-old<sup>1</sup>; therefore, it is critical to identify possible risk factors of CKD in adults younger than 65 to decrease the incidence of CKD. Our study demonstrated that betelnut use may be a more important risk factor of CKD than are smoking and alcohol in individuals younger than 65. Further study is needed to determine the quantity and duration of betelnut use in

association to the decrease of renal function.

In conclusion, our study demonstrates a significant association between betelnut use and chronic kidney disease in adults with an 8.1% prevalence of betelnut use. The association between betelnut use and CKD is independent of body mass index, smoking, alcohol consumption, and hyperlipidemia. More studies are needed to confirm our finding and to investigate the effect of betelnut cessation in reducing the prevalence of CKD.

## References

- Kuo HW, Tsai SS, Tiao MM, Yang CY. Epidemiological features of CKD in Taiwan. *Am J Kidney Dis.* 2007;49:46–55.
- Yang WC, Hwang SJ, Chiang SS, Chen HF, Tsai ST. The impact of diabetes on economic costs in dialysis patients: experiences in Taiwan. *Diabetes Res Clin Pract.* 2001;54(Suppl 1):S47–S54.
- Lysaght MJ. Maintenance dialysis population dynamics: current trends and long-term implications. *J Am Soc Nephrol.* 2002;13(Suppl 1):S37–S40.
- K/DOQI clinical practice guidelines for chronic kidney disease: evaluation, classification, and stratification. *Am J Kidney Dis.* 2002;39:S1–266.
- Gupta PC, Warnakulasuriya S. Global epidemiology of areca nut usage. *Addict Biol.* 2002;7:77–83.
- Ho PS, Ko YC, Yang YH, Shieh TY, Tsai CC. The incidence of oropharyngeal cancer in Taiwan: an endemic betel quid chewing area. *J Oral Pathol Med.* 2002;31:213–219.
- Yen AM, Chiu YH, Chen LS, et al. A population-based study of the association between betel-quid chewing and the metabolic syndrome in men. *Am J Clin Nutr.* 2006;83:1153–1160.
- Tseng C-H. Betel nut chewing is independently associated with urinary albumin excretion rate in type 2 diabetic patients. *Diabetes Care.* 2006;29:462–463.
- Hyman DJ, Pavlik VN. Characteristics of patients with uncontrolled hypertension in the United States. *N Engl J Med.* 2001;345:479–486.
- Hwang SJ, Ballantyne CM, Sharrett AR, et al. Circulating adhesion molecules VCAM-1, ICAM-1, and E-selectin in carotid atherosclerosis and incident coronary heart disease cases: the Atherosclerosis Risk In Communities (ARIC) study. *Circulation.* 1997;96:4219–4225.
- Schachinger V, Britten MB, Zeiher AM. Prognostic impact of coronary vasodilator dysfunction on adverse long-term outcome of coronary heart disease. *Circulation.* 2000;101:1899–1906.
- Gigleux I, Gagnon J, St-Pierre A, et al. Moderate alcohol consumption is more cardioprotective in men with the metabolic syndrome. *J Nutr.* 2006;136:3027–3032.
- Nelson BS, Heischouer B. Betel nut: a common drug used by naturalized citizens from India, Far East Asia, and the South Pacific Islands. *Ann Emerg Med.* 1999;34:238–243.
- Wang SC, Tsai CC, Huang ST, Hong YJ. Betel nut chewing: the prevalence and the intergenerational effect of parental behavior on adolescent students. *J Adolesc Health.* 2004;34:244–249.
- Chang WC, Hsiao CF, Chang HY, et al. Betel nut chewing and other risk factors associated with obesity among Taiwanese male adults. *Int J Obes (Lond).* 2006;30:359–363.
- Chung FM, Chang DM, Chen MP, et al. Areca nut chewing is associated with metabolic syndrome: role of tumor necrosis factor- $\alpha$ , leptin, and white blood cell count in betel nut chewing-related metabolic derangements. *Diabetes Care.* 2006;29:1714.
- Wary KK, Sharan RN. Aqueous extract of betel-nut of north-east India induces DNA-strand breaks and enhances rate of cell proliferation in vitro. Effects of betel-nut extract in vitro. *J Cancer Res Clin Oncol.* 1988;114:579–582.
- Stengel B, Tarver-Carr ME, Powe NR, Eberhardt MS, Brancati FL. Lifestyle factors, obesity and the risk of chronic kidney disease. *Epidemiology.* 2003;14:479–487.
- Shankar A, Klein R, Klein BE. The association among smoking, heavy drinking, and chronic kidney disease. *Am J Epidemiol.* 2006;164:263–271.
- Chen TH, Chiu YH, Boucher BJ. Trans-generational effects of betel-quid chewing on the development of the metabolic syndrome in the Keelung Community-based Integrated Screening Program. *Am J Clin Nutr.* 2006;83:688–692.
- Mannan N, Boucher BJ, Evans SJ. Increased waist size and weight in relation to consumption of Areca catechu (betelnut); a risk factor for increased glycaemia in Asians in east London. *Br J Nutr.* 2000;83:267–275.
- Hsu CC, Hwang SJ, Wen CP, et al. High prevalence and low awareness of CKD in Taiwan: a study on the relationship between serum creatinine and awareness from a nationally representative survey. *Am J Kidney Dis.* 2006;48:727–738.

# The impact of cigarette smoking, alcohol drinking and betel quid chewing on the risk of calcium urolithiasis.

Liu CC, Huang SP, Wu WJ, Chou YH, Juo SH, Tsai LY, Huang CH, Wu MT.

Department of Urology, Kaohsiung Medical University Hospital, Kaohsiung, 807, Taiwan.

## Abstract

**PURPOSE:** To evaluate the independent and combined effects of alcohol drinking, cigarette smoking and betel quid chewing on the risk of calcium urolithiasis.

**METHODS:** A total of 354 cases diagnosed with calcium urolithiasis and 354 age- and sex-matched healthy controls were recruited from Kaohsiung Medical University Hospital between June 2003 and February 2007. All subjects completed a detailed questionnaire survey and provided blood and urine samples for biochemical evaluation.

**RESULTS:** Current cigarette smoking (odds ratio [OR], 1.66; 95% confidence interval [95%CI], 1.11-2.50; p=0.014) and current betel quid chewing (OR, 1.97; 95%CI, 1.06-3.64; p=0.032), but not current alcohol drinking, were found to be independent risk factors for the development of calcium urolithiasis. The joint risk of current cigarette smoking and current betel quid chewing was increased 3.73-fold (OR, 3.73; 95%CI, 1.81-7.70, p<0.001) compared to those who had neither habit.

**CONCLUSIONS:** Both cigarette smoking and betel quid chewing are independent risk factors for the development of calcium urolithiasis. The risk effect is even strengthened when subjects have both habits. These findings suggest users can greatly reduce the risk of calcium urolithiasis if they quit these two habits.

## The increased risk of urinary stone disease in betel quid chewers.

Allen SE, Singh S, Robertson WG.

Centre for the Prevention and Treatment of Urinary Stones, Institute of Urology and Nephrology, University College London, 48 Riding House Street, London, W1W 7EY, UK. sianallen@gmail.com

### **Abstract**

The chewing of betel quid is a common practice in many countries of the world, particularly in Southeast Asia. The quid consists of a preparation of areca nut, betel leaf and calcium hydroxide "lime" paste ("chuna"). For the first time, we present a study that links its use to urinary stone disease. Eight patients (seven male and one female) who presented to our Stone Unit with recurrent urinary stones were included in the study. All were from the Indian subcontinent and were found to regularly chew betel. The patients underwent metabolic screening including blood, random urine and 24-h urine tests, quantitative chemical analysis of their calculi (where possible) and each completed a 7-day Diet Diary on his/her free, home diet. The study demonstrated a high incidence of hypercalciuria, a tendency to pass an alkaline urine and low urinary citrate excretion among the patients. Together these urinary risk factors increase the probability of developing both calcium phosphate-containing and calcium oxalate-containing stones. In support of this hypothesis, the patients were found to form stones consisting mainly of calcium phosphate but mixed with calcium oxalate. It is concluded that the use of calcium hydroxide "chuna" in the betel quid is the major contributor to the cause of urinary stones in its users. Moreover, the development of urinary lithiasis in such patients may be a precursor to milk-alkali syndrome in those individuals whose chewing habit is more extensive than in the patients in this study and who do not seek to decrease their habit over the long term.